

High Power Pulsed Laser Diodes 905-Series

Features

- Single and stacked devices up to 130 Watts
- Proven AlGaAs high reliability structure
- 1 W/A efficiency with 25° beam divergence
- Excellent temperature stability
- Hermetic and custom designed package

Applications

- Range finding
- Surveying equipment
- Weapons simulation
- Laser radar
- Security barrier
- Optical trigger

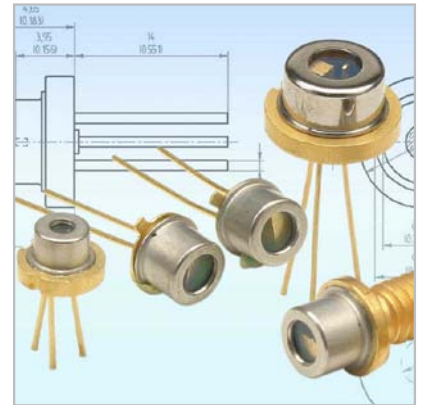

Optical Characteristics at $t_{RT} = 21^{\circ}\text{C}$

| | Min | Typ | Max | Units |
|--|-----|----------|-----|------------------------|
| Wavelength of peak radiant intensity λ_m | 895 | 905 | 915 | nm |
| Spectral bandwidth $\Delta\lambda$ at 50% intensity points | | 5 | | nm |
| Wavelength temperature coefficient | | 0.27 | | nm/ $^{\circ}\text{C}$ |
| Beam spread (50% peak intensity) Parallel to junction plane \parallel | | 12 | | Degrees |
| Perpendicular to junction plane \perp Single element Stacks | | 25 30 | | Degrees Degrees |

SINGLE CHIPS

Single Chip Characteristics at $t_{RT} = 21^\circ\text{C}$, $t_w = 150\text{ ns}$, $P_{rr} = 6.66\text{ kHz}$

| Parameter | 905D1S1.5X | 905D1S03X | 905D1S06X | 905D1S09X | 905D1S12X | 905D1S16X |
|--------------------------------------|------------------------|----------------------|-----------------------|-----------------------|-----------------------|-----------------------|
| P_O at i_{FM} (min) | 3.0 W | 6.0 W | 13.0 W | 19.0 W | 26.0 W | 34.0 W |
| Emitting area | 37.5 x 1 μm | 75 x 1 μm | 150 x 1 μm | 230 x 1 μm | 300 x 1 μm | 400 x 1 μm |
| Max peak forward current i_{FM} | 3.5 A | 7 A | 15 A | 22 A | 30 A | 40 A |
| I_{th} typ | 100 mA | 200 mA | 400 mA | 600 mA | 800 mA | 1200 mA |

STACKED ARRAYS

Stacked Chip Characteristics at $t_{RT} = 21^\circ\text{C}$, $t_w = 150\text{ ns}$, $P_{rr} = 6.66\text{ kHz}$

| Parameter | 905D2S06X | 905D3S09X | 905D3S12X | 905D4S12X | 905D4S16X |
|--------------------------------------|-------------------------|-------------------------|-------------------------|-------------------------|-------------------------|
| Number of elements | 2 | 3 | 3 | 4 | 4 |
| PO at i_{FM} (min) | 25 W | 55 W | 70 W | 90 W | 130 W |
| Emitting area | 150 x 125 μm | 230 x 225 μm | 300 x 225 μm | 300 x 340 μm | 400 x 340 μm |
| Max peak forward current i_{FM} | 15 A | 22 A | 30 A | 30 A | 40 A |
| I_{th} typ | 400 mA | 600 mA | 800 mA | 800 mA | 1200 mA |

Absolute Maximum Ratings

| Maximum ratings | Limiting values |
|--|---|
| Peak reverse voltage | 6 V |
| Pulse duration Single element Stacks | 1 μs 200 ns |
| Duty factor | 0.1% |
| Temperature - Storage - Operating | -55 $^\circ\text{C}$ to + 100 $^\circ\text{C}$ -45 $^\circ\text{C}$ to + 85 $^\circ\text{C}$ |
| Lead soldering - 5 seconds max at | 200 $^\circ\text{C}$ |

Figure 1:
Optical output power vs. forward current

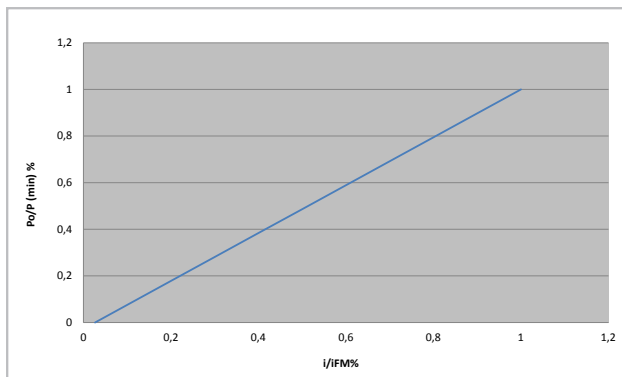

Figure 2:
Optical output power vs. temperature

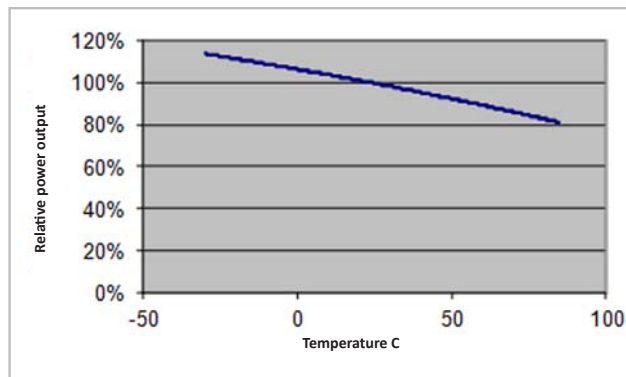

Figure 3:
Optical output power vs. half angle

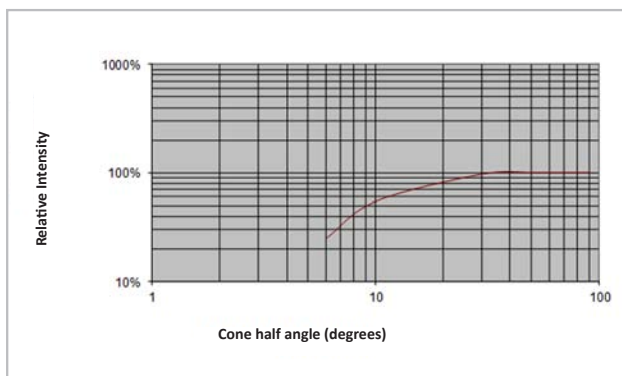

Figure 4:
Wavelength vs. temperature

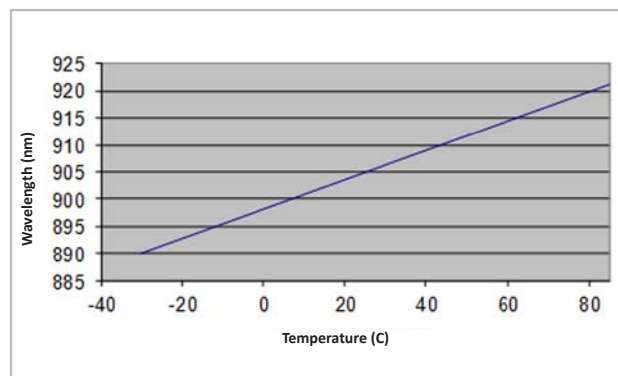

Figure 5:
Spectral plot distribution

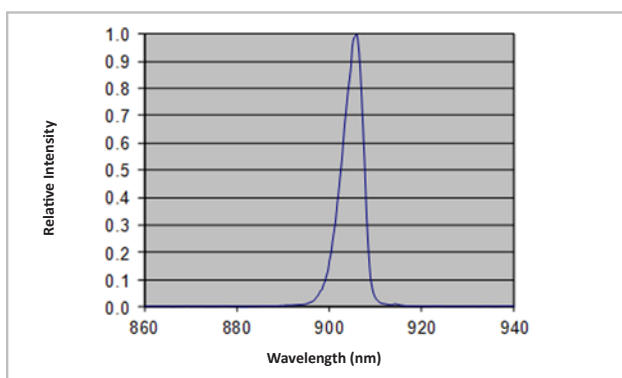

Figure 6:
Far field emission pattern parallel and perpendicular to junction plane

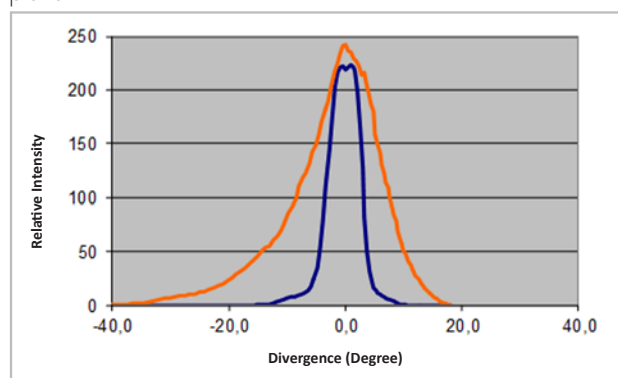
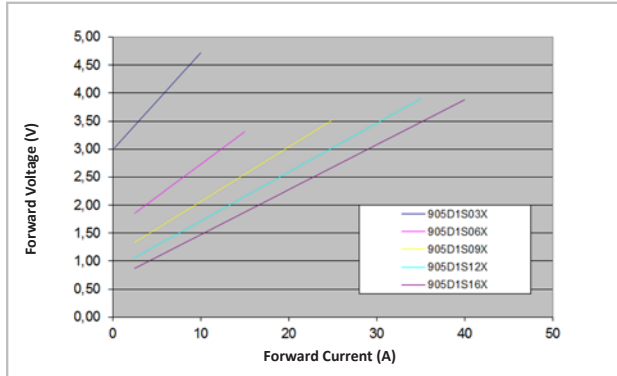
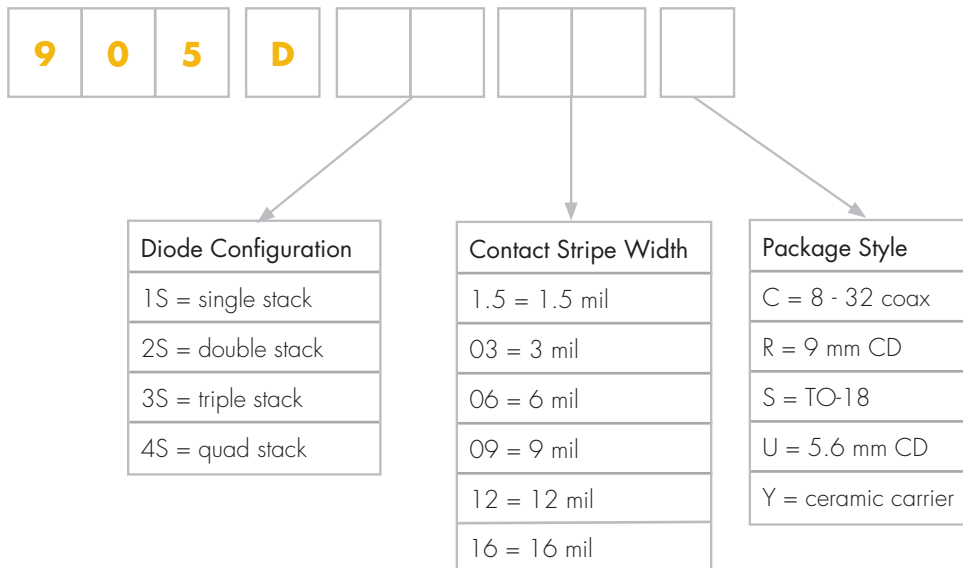

Figure 7:
905D1S series, static Vf



Product Number Designations



Package Drawings

Package C 8 - 32 coax

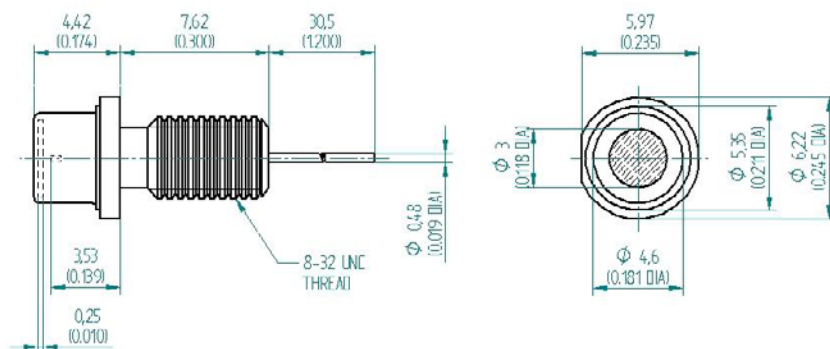

Package C: Pin Out: Case (-), Pin (+), Inductance 12 nH

Package R 9 mm CD

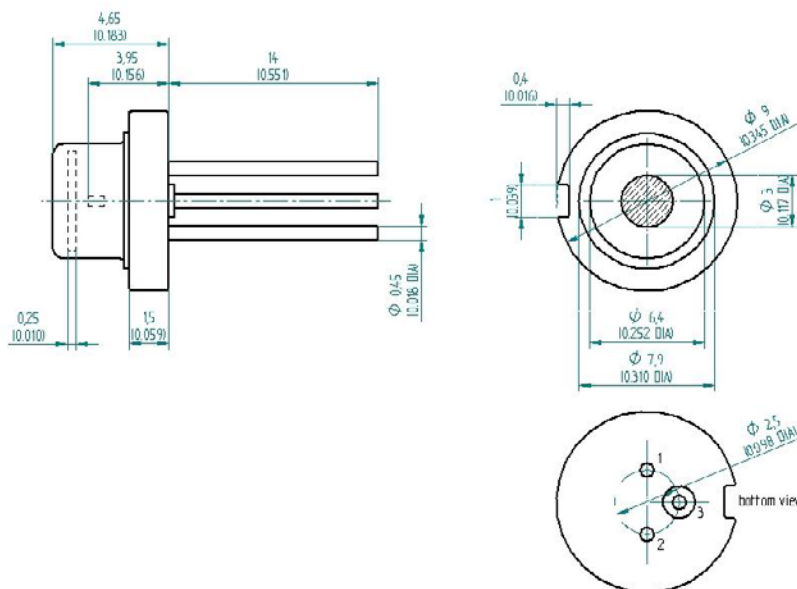

Package R: Pin Out: 1. LD Anode (+), 2. NC, 3. LD Cathode (-) Case, Inductance 6.8 nH

Package S TO-18

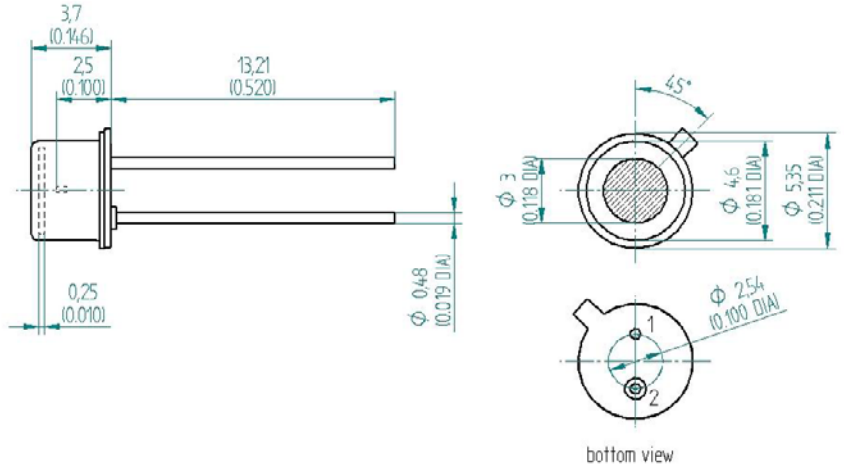

Package S: Pin Out: 1. LD Anode (+),
2. LD Cathode (-) Case, Inductance 5.2 nH

Package U 5.6 mm CD

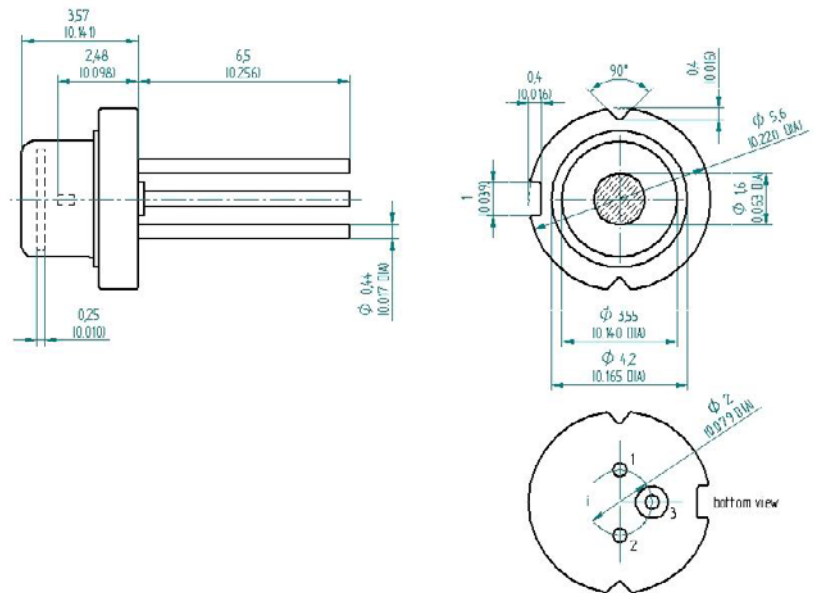

Package U: Pin Out: 1. LD Anode (+),
2. NC,
3. LD Cathode (-) Case, Inductance 5.0 nH

Package Y ceramic carrier

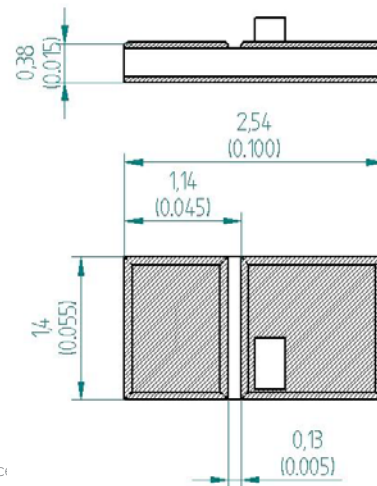
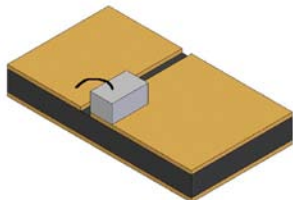

Package Y: Pin Out: 1. LD Anode (+),
2. LD Cathode (-) Case, Inductance

Product Changes

LASER COMPONENTS reserves the right to make changes to the product(s) or information contained herein without notice. No liability is assumed as a result of their use or application.

Ordering Information

Products can be ordered directly from LASER COMPONENTS or its representatives. For a complete listing of representatives, visit our website at www.lasercomponents.com

Custom designed products are available on request.

Laser Safety

Personal Hazard:

Depending on the mode of operation, these devices emit highly concentrated non visible infrared light which can be hazardous to the human eye. Products which incorporate these devices have to follow the safety precautions given in IEC 60825-1 "Safety of laser products".

Handling Precautions:

Products are subject to the risks normally associated with sensitive electronic devices including static discharge, transients, and overload.

