

Für Dauereinsatz ohne Leistungsverlust.

- Hochwertige 3-fach geschlitzte Stahlspannzangen für extreme Rundlaufgenauigkeit. Kein Rattern und Schlagen der Einsatzwerkzeuge. Kein Lösen bei seitlicher Belastung.

# PROXXON MICROMOT ON STEROIDS

Home build rotary tool (3) - 4 and 5 ;-)



The basic idea is to build a HF-cutter, wich is brushless- this means no or very little wear to the motor itself. Over the years I have consumed quite a few rotary tools. I feel that has got to stop now.

The concept of modifying a standard rotary with a brushless motor is allready several years in my mind.

Some time ago I found this Proxxon - micromot 40 - rotary in a German hobbyshop. Proxxon Germany produces highs quality tools for hobby purpose. This handtool has been designed for manual use. It has a set high quality hardened steel spanners and claims good centricity, wich was the main reason to buy this set.

Teoretically this brushless motor could fit in the proxxon housing, but testruns of the motor made clear that heat would become a bigger issue than I thought in the first place. Also the ceramic bearing I did have in mind would not fit.

So the target is for now to build a test-rig to proof the concept in real life..... This setup will be put to use on my XXL classic for small cutters 1-3 mm.

If this all works out well the final design should be much sleeker and professional looking. This rotary should also be a bigger, heavier tool - 400-600 - Watts for my other 2007 CNC machine.





This is a tsunami 25 amps esc .  
Normally driven with a RC receiver.  
Now driven by the  
Conrad Servo tester

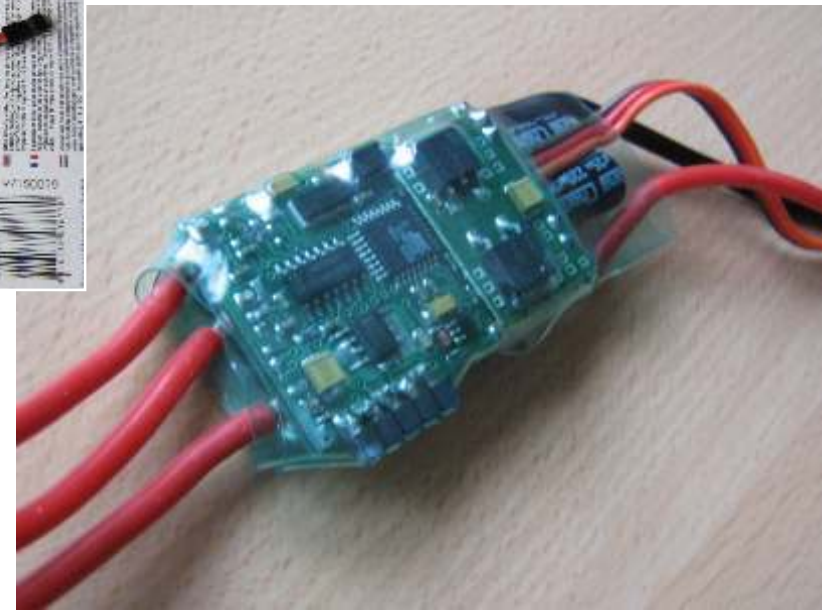

Finding affordable parts where originally the problem.  
For RC purpose these parts are now available for decent prices.

Here shown the lineup of the structural essence.  
The adapter was the main problem as that had to be made with  
the highest accuracy possible

Within this setup the motors bearings will prob be  
the weakest link as the shaft bearing will be ceramic.  
These are 608 ceramic skate bearings with stainless rings from e-bay



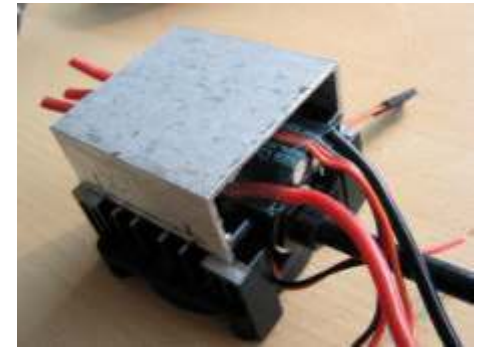

CNC - cut of course..... .....on my Bracket machine using a 5mm single side cutter

.....Some scrap U shape alu profile over the cooler-block protecting the electronics



Conrad Nr 1901151



Connections



.....The condensers do fit the gap and the cooling plate freed from its plastic is glued to the cooler. The screw on the side grab behind the coolerbody's fins.



This is the converted tsunami 25 amps esc . Normally driven with a RC receiver. Now driven by the Conrad Servo tester.

For easy assembly on the machine and to provide cooling an Pentium II cooler has been converted. The servotester could also be incorporated resulting into a compact frequency regulator.

The powersupply will be custom made as that should and very constant,flat, powerfull 10-15 Amps 12 Volts. (I will also use that for charging Nicad-NiMh battery's )





.....This is the motor mount into a cooler body cut and shaped on a lathe As this is a testrig it was convenient to mount it onto a piece of scrap U-shaped Alu. All parts are easy accesble this way.

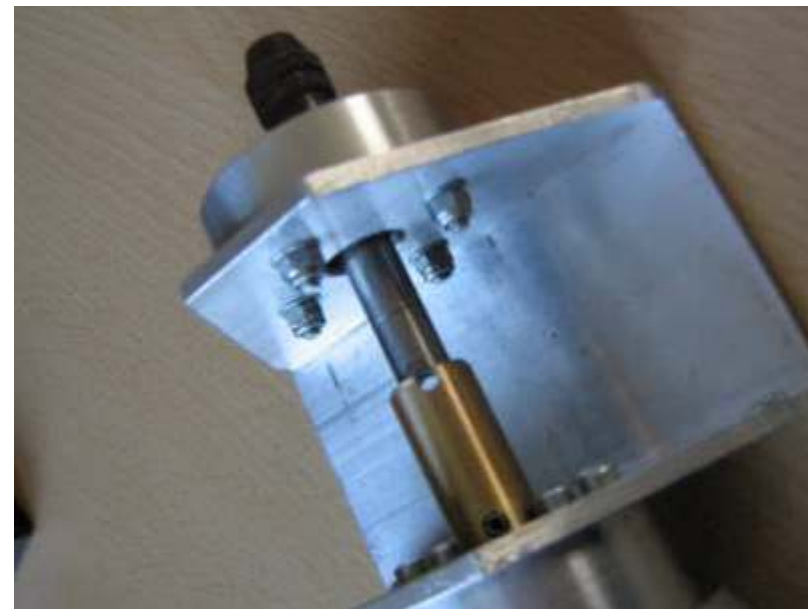

.....To mount the motor onto the shaft this adapter had to be made with great care. Flexible setups with these higher RPM's may not be such a good idea. Maybe beltdriving could have been an option but found this to be more compact in the end.

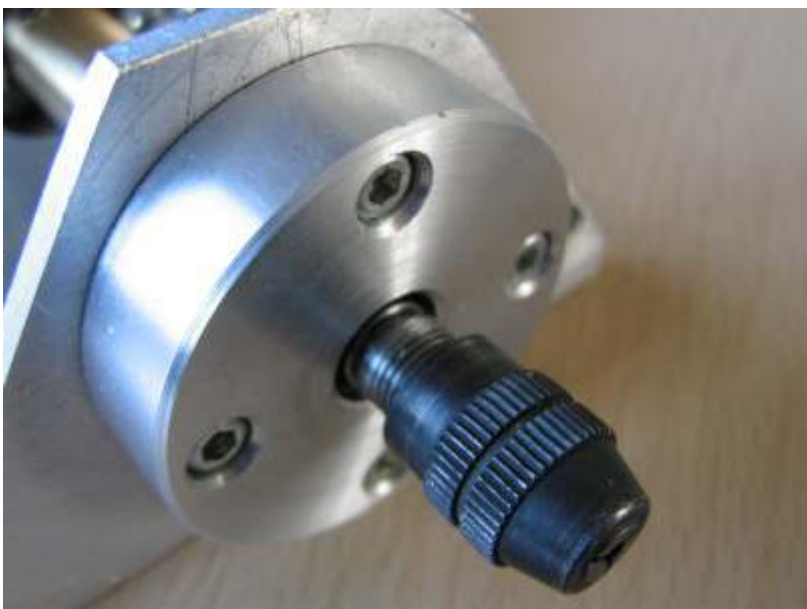

.....For alignment purpose the bearing cage was made adjustable wich worked out well in the end. By having the motor run the bearing-cage was shifted by the sound to get it set aligned properly.

This is a 4 amps powersupply. It can replace the conventional transformer reducing cost a bit. The Power king has been tested with the controller and works as hoped for.

Lateron this one will be replaced by a 10 Amps version keeping this 4 Amps for my RC 12V charger.





Costs:

Brushless motor	23€
ESC	35€
Proxxon	25€
Power supply	35€
Materials	???
Time	(too much!)
<b>Total est. at</b>	<b>140€</b>

(Not for cheapos right now -sorry)

Clocking the rotary on the cuttertool itself resulted within 1  $\mu$ m wich is amazing to me (using a simple chinese lathe to create the adapter)  
The Proxxon spanners have proven here to be top quality!

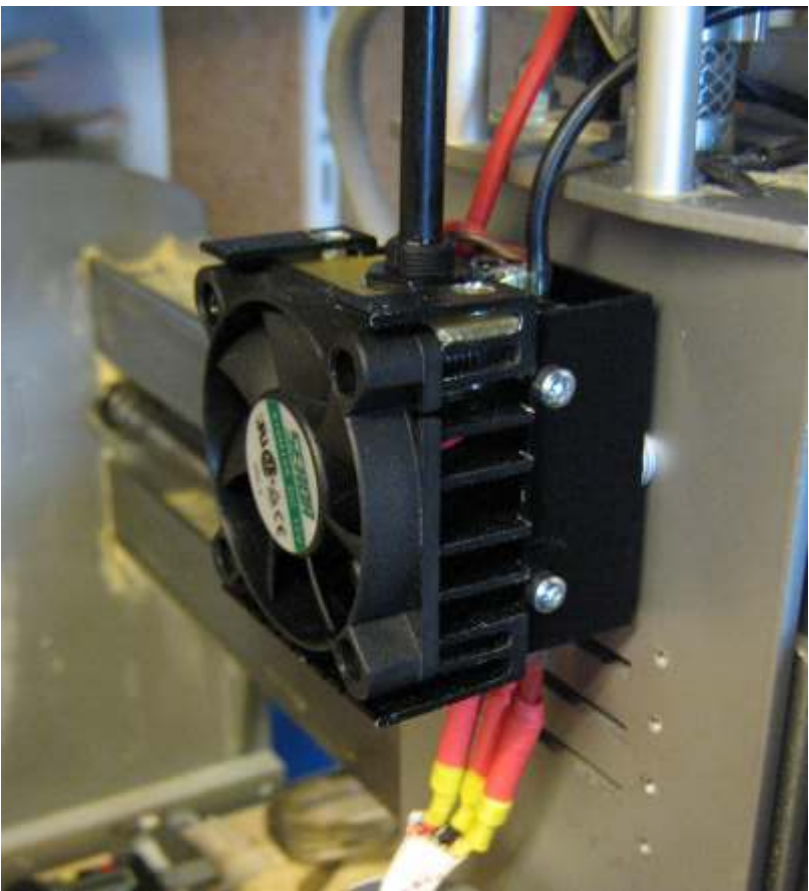

Result



EXPERIMENTAL  
build on own risk!





1st the RPM controller had flaws  
2nd the motor got to hot - only 15min use...  
Positive I found the high RPM with small tools

So I converted it with a HET-RC motor wich layed around  
This worked much better but lacked RPM and power  
for my purpose

# Results

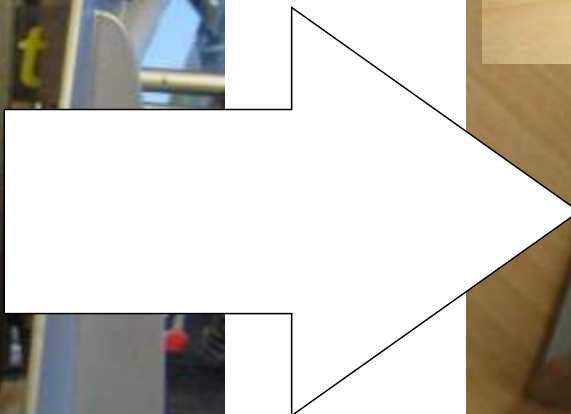



On RC-Groups there was a thread about a proxxon conversion with a larger LRK what seemed like a good idea...

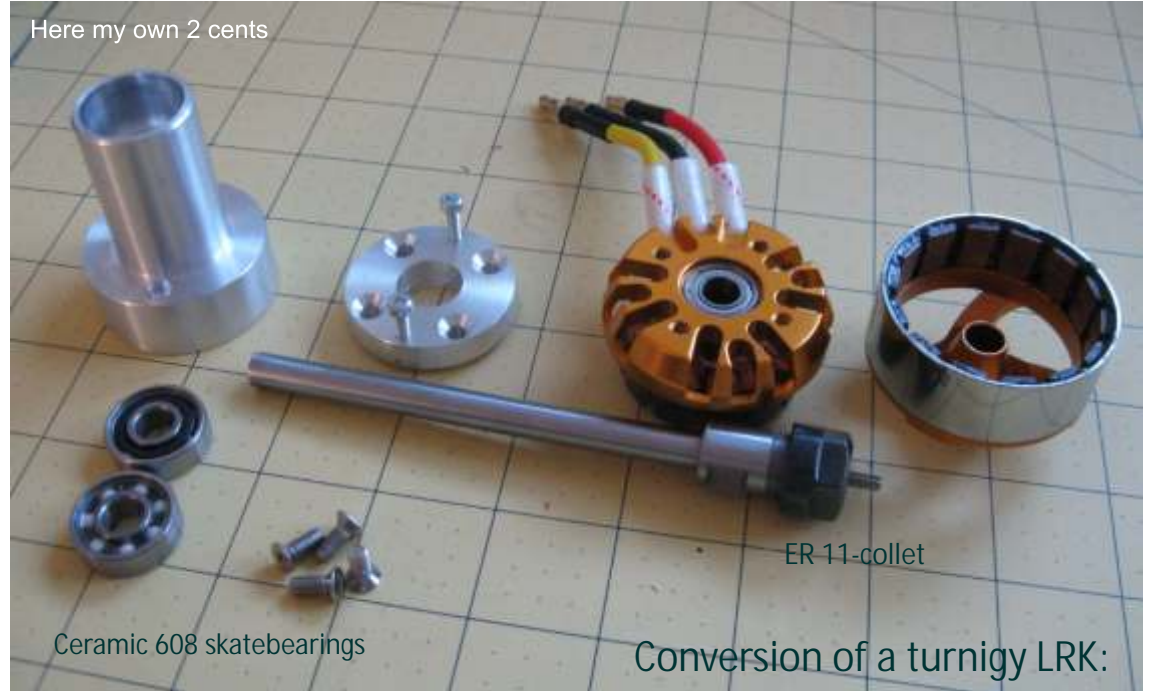

Here my own 2 cents

ER 11-collet

Ceramic 608 skatebearings

Conversion of a turnigy LRK:



Testing with two car batteries did proof to work superb cutting this small Aluminium folding hub. So I did get me a 30V 10 Amps powersupply. Using the small pot it can be adjusted to 26V

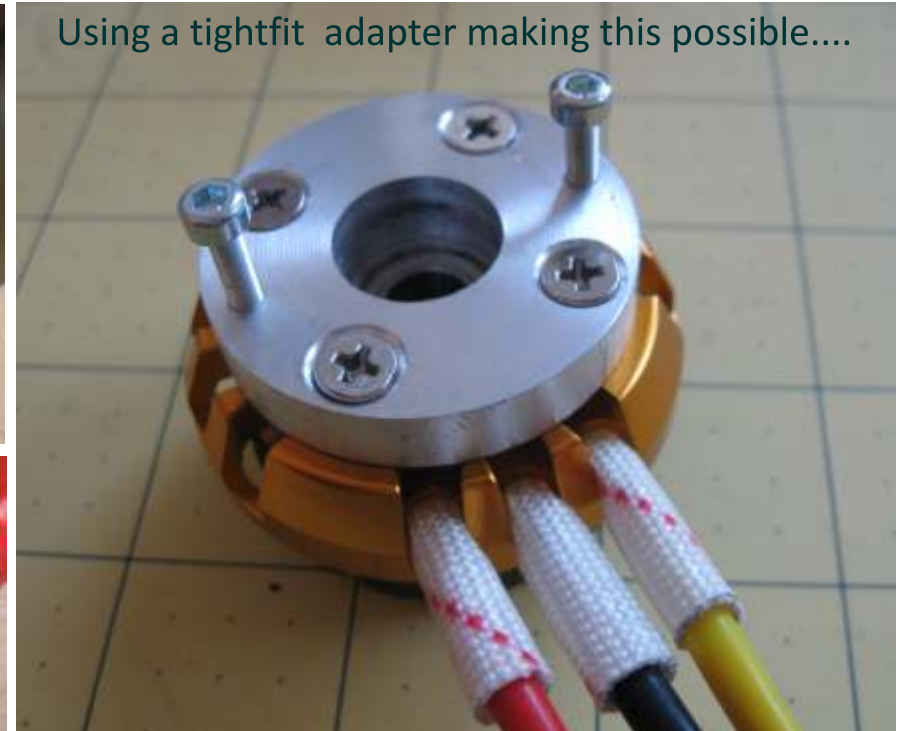

Using a tightfit adapter making this possible....



Note: rebuilds are at own risk!

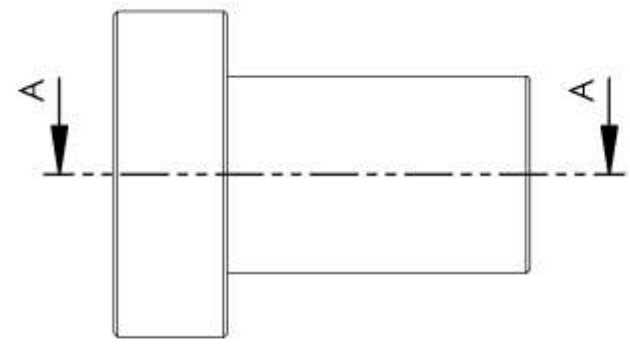
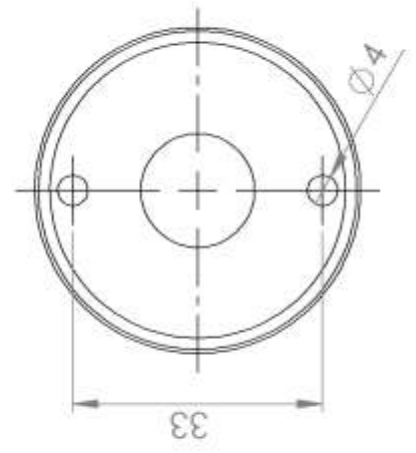
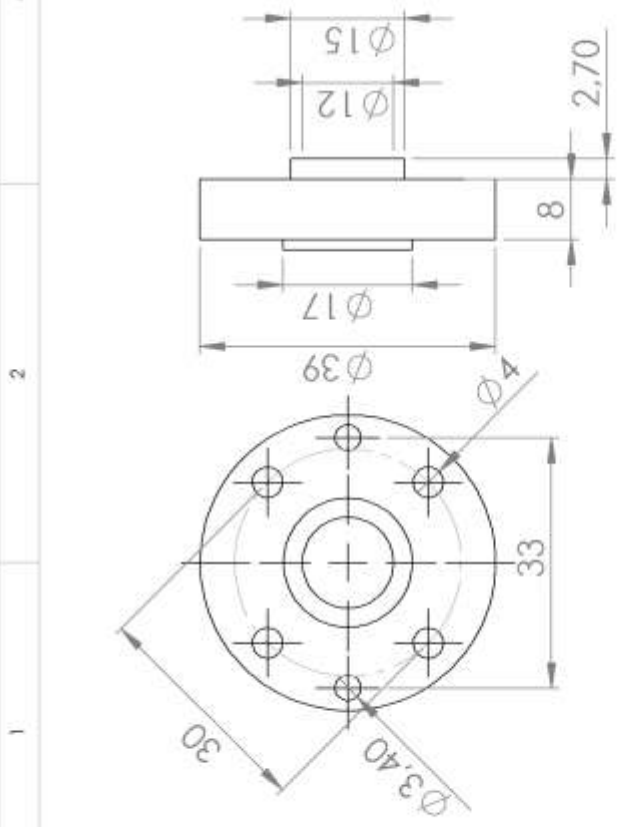
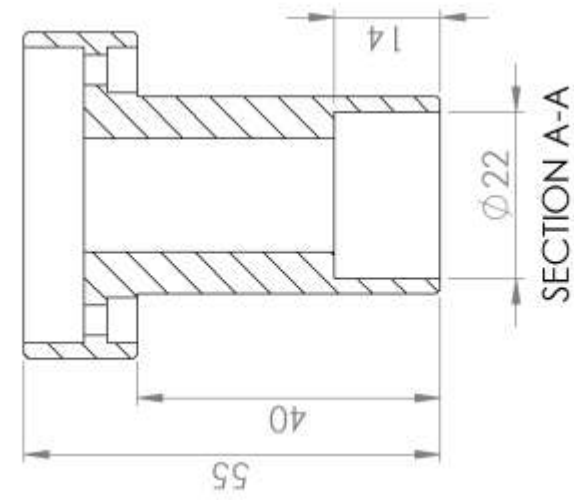
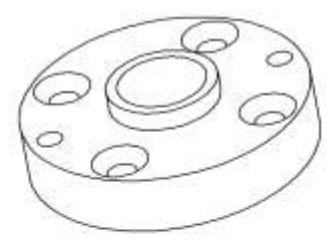
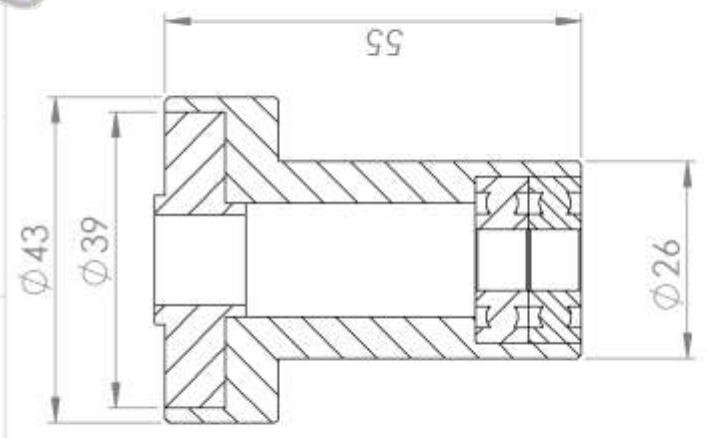

	<b>Ontwerpstudio Zoltar</b> created: woensdag 23 december 2010 11:01:59 modified: zondag 27 februari 2011 12:28:07	Scale: <b>1:1</b> Proj:	Drawn by: <b>C.Reinders</b> Title: <b>Opname Turnigny C5045-890 -</b>	Size: <b>A3</b> SHEET 1 OF 1
	Contact : <b>Ontwerpstudio Zoltar</b> Esdoornhof 223 NL-8266GH Kampen zoltar@home.nl fax +31 84 7274454	Material : <b>Alu</b> DWG NO : <b>XXXXX</b>	Copyrights zoltar	

Costs est :  
 motor 30€  
 controller 30€  
 servotester 10€  
 shaft 15€  
 collets 25€  
 hobbytime/materials??

For those who need some dimensions