

# INCREMENTAL LINEAR SCALES

**TGM 130**

**Optoelectronic**

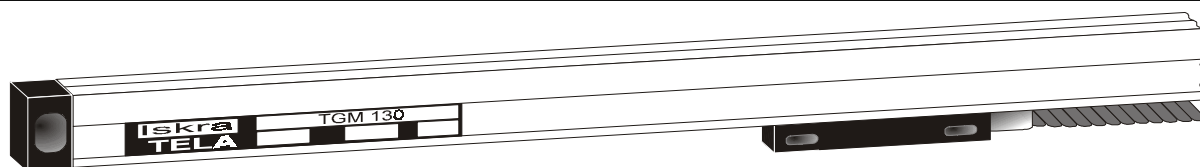

## GENERAL DESCRIPTION:

The TGM 130 is an optoelectronic incremental sealed linear scale, applied in numerous industrial areas for high-precision measuring of positions (machine tool industry, positioning systems, robotics, etc.).

**Measuring lengths:** 70 to 1240 mm

**Cross section:** 18 x 32 mm (46 mm)

**Accuracy:**  $\pm 10, \pm 5, \pm 3 \mu\text{m}$

**Resolution:** 0.5, 1, 2, 5, 10  $\mu\text{m}$

**Output signals:** DO (square wave)

DI (square wave inverted signals)

DS (square inverted signals RS422A)

SI (sine-wave current signals)

SV (sine-wave voltage signals 1Vpp)

## OPERATING PRINCIPLE:

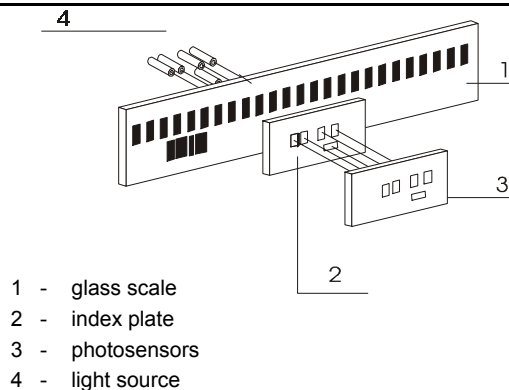

- 1 - glass scale
- 2 - index plate
- 3 - photosensors
- 4 - light source

## MECHANICAL DATA:

<b>Standard measuring length "Lm" (mm)</b>	70/120/170/220/270/320/370/420/470/520/570/620/670/720/770/820/920/1020/1140/1240
<b>Reference mark</b>	Standard position: for $L_m \leq 1020$ mm: 35 mm from the beginning to the end of measuring length for $L_m \geq 1140$ mm: 45 mm from the beginning to the end of measuring length Other position optional at spacing of 50 mm along the measuring length.
<b>Accuracy class</b>	$\pm 10 \mu\text{m}, \pm 5 \mu\text{m}, \pm 3 \mu\text{m}$
<b>Interval</b>	20 $\mu\text{m}$ or 40 $\mu\text{m}$
<b>Resolution</b>	0.5, 1, 2, 5, 10 $\mu\text{m}$ for DI or DS output signals; 5 or 10 $\mu\text{m}$ square wave output signals DO (12 V)
<b>Maximal speed</b>	45 m/min continuously, 60m/min temporarily
<b>Permissible acceleration</b>	30 $\text{m/s}^2$
<b>Moving force for scanning unit</b>	$\leq 5\text{N}$
<b>Degree of mechanical protection</b>	IP 53 (in compliance with mounting instructions); IP 64 with compressed air purge
<b>Vibrations (50...2000 Hz)</b>	30 $\text{m/s}^2$ , option 300 $\text{m/s}^2$
<b>Shocks (11ms)</b>	100 $\text{m/s}^2$
<b>Temperature</b>	operating: 0 $\text{°C}$ to 50 $\text{°C}$ storage: -20 $\text{°C}$ to 70 $\text{°C}$
<b>Permissible relative humidity</b>	20% - 70%
<b>Cable length</b>	standard 3m, extension on order to 20m (SI signals), extension on order to 50m (DI and DS signals), extension on order to 150m (SV signals)
<b>Mass</b>	0.45 kg + 0.65 kg/m

## ELECTRICAL DATA:

Output signals	Voltage $U_n$	Current $I_n$
DS - square-wave inverted RS422A	5 V $\pm 5\%$	$\leq 130$ mA
DI - square-wave inverted	5 V $\pm 5\%$	$\leq 120$ mA
SI - sine-wave current	5 V $\pm 5\%$	$\leq 70$ mA
DO - square-wave	12 V $\pm 5\%$	$\leq 120$ mA
SV - sine wave voltage	5 V $\pm 5\%$	$\leq 150$ mA

### ELECTRICAL DATA:

#### Square-wave signals with inverted signals and RS 422A - DI, DS:

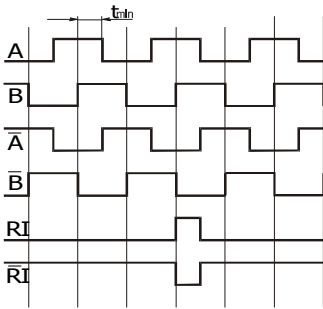

DS (RS- 422 A)	
$I_{sink} = 20 \text{ mA}$	$U_{OL} \leq 0.5 \text{ V}$
$I_{source} = -20 \text{ mA}$	$U_{OH} \geq 2.5 \text{ V}$
$t_{LH} = t_{HL} \leq 30 \text{ ns; without load}$	
DI	
$I_{sink} = 15 \text{ mA}$	$U_{OL} \leq 0.5 \text{ V}$
$I_{source} = -15 \text{ mA}$	$U_{OH} \geq 4.0 \text{ V}$
$t_{LH} = t_{HL} \leq 60 \text{ ns; without load}$	

#### Square-wave output signals - DO:

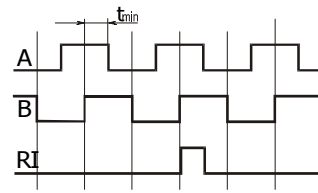

Signal level ...	HTL	Transition time:
$I_{sink} = 1 \text{ mA}$	$U_{OL} \leq 0.5 \text{ V}$	$t_{LH} = t_{HL} \leq 60 \text{ ns, without load}$
$I_{source} = 4 \text{ mA}$	$U_{OH} \geq 11 \text{ V}$	$t_{min} = f(v)$

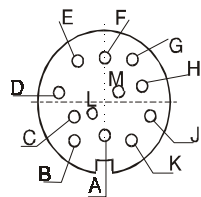

12 pole connector (Amphenol) square-wave output signals (DI, DS)

contact	A	B	C	D	E	G	H	K	L
signal	shield	0 V	A	$\bar{A}$	B	RI	$\bar{RI}$	+V	$\bar{B}$

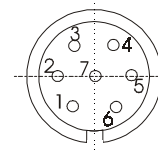

7 pole connector (Amphenol) square-wave output signals (DO)

contact	1	2	3	4	5	6	7
signal	0 V		A	B	+V	RI	shield

#### Sinusoidal output signals - SI:

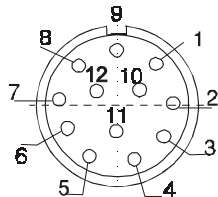

12 pole connector (Contact) square-wave output signals (DI, DS)

contact	1	2	3	4	5	6	7	8	9	10	11	12
signal	$\bar{B}$	+5V	RI	$\bar{RI}$	A	$\bar{A}$		B	shield	0V	0V	+5V

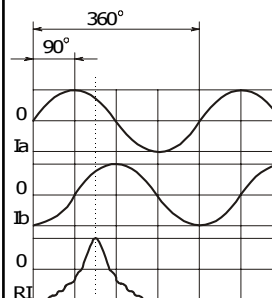

#### Amplitude of signals

$I_b = I_a = 7 - 16 \mu\text{A}_{pp}$ at load 1 kW
$I_{RI} = 2 - 8 \mu\text{A}_{pp}$ used component

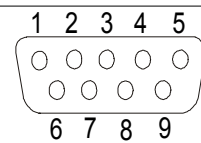

9 pole connector (D-Sub) square-wave output signals (DI, DS)

contact	1	2	3	4	5	6	7	8	9
signal	shield	$\bar{RI}$	$\bar{B}$	$\bar{A}$	+5V	RI	B	A	0V

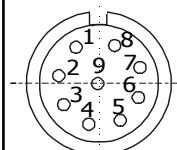

9 pole connector (Contact) sine-wave output signals (SI)

contact	1	2	3	4	5	6	7	8	9
signal	$I_{a+}$	$I_{a-}$	+5 V	0 V	$I_{b+}$	$I_{b-}$	$I_{RI+}$	$I_{RI-}$	shield

Sine wave voltage signals 1 V pp SV (remark: for details see Electrical DATA on page 28)

### SPEED AND SCANNING UNIT

The maximum measuring speed allowed by the mechanical construction is given in the mechanical data table.

The dependence of minimum time interval between two neighbouring fronts of square-wave output signals is given at right.

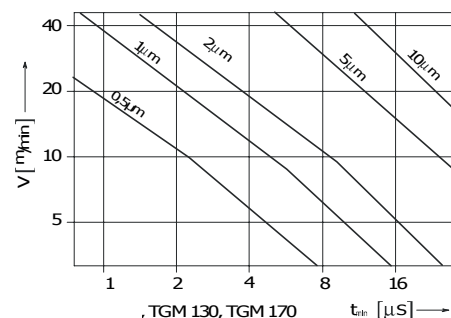

### DIMENSIONS:

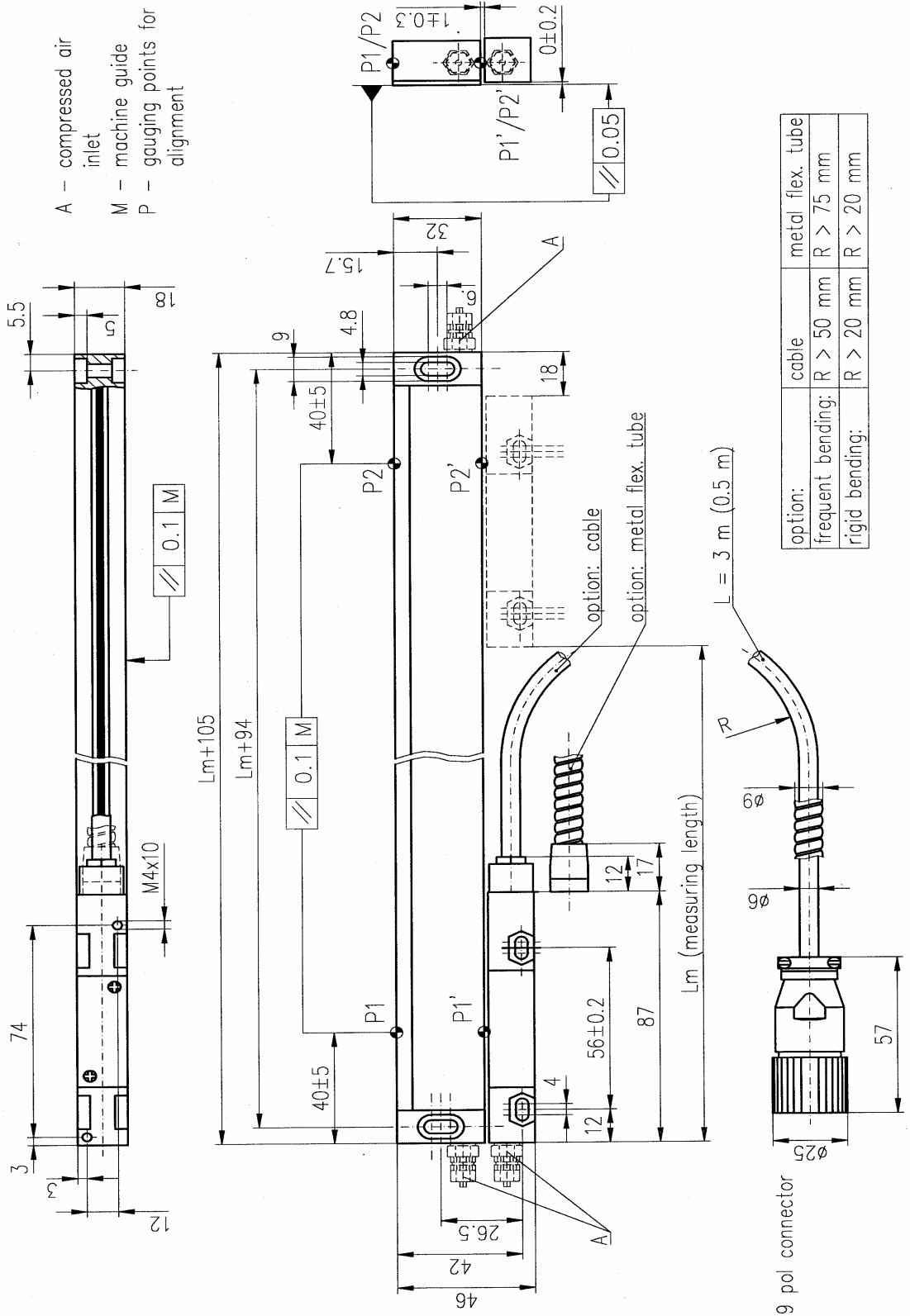

**ORDERING DATA:**

Standard requirements							Special requirements			
TGM130	- XX -	X -	XX -	X -	X -	XXXX-	XX-	X-	X-	X-
							<p><b>Air inlet connection</b> [special requirement]: 0 ... without 1 ... with</p> <p><b>Metal flexible tube:</b> 0 ... without 1 ... with</p> <p><b>Connector</b> is defined with electrical versions DO, DI, DS or SI: 1 ... Amphenol 12 pole 2 ... Amphenol 7 pole 3 ... Contact 9 pole (male screw) 4 ... Contact 12 pole (female screw) 5 ... Contact 9 pole (female screw) 6 ... Contact 12 pole (male screw) 7 ... D-Sub 9 pole 9 ... other (specify) 0 without connector</p> <p><b>Cable length</b> in [m]: Standard 3 m : 03 Example: 1.5 m : 1.5 25 m : 25</p> <p><b>Measuring length:</b> Standard length</p> <p><b>Accuracy:</b> 3 ... ±3µm 5 ... ±5µm 0 ... ±10µm</p> <p><b>Reference mark:</b> 0 ... without 1 ... in the middle 2 ... on agreement 3 ... 2x35mm (see mechanical data) 2x45mm (see mechanical data)</p> <p><b>Output signals:</b> DI, DS, SI, DO, SV</p> <p><b>Resolution (DI, DO, DS):</b> 0.5 ... 0.5 µm 1 ... 1 µm 2 ... 2 µm 5 ... 5 µm 0 ... 10 µm</p> <p><b>Periode (SI):</b> 20 ... 20 µm 40 ... 40 µm</p> <p><b>Voltage supply:</b> 05 ... 5 V 12 ... 12 V</p>			
							<p><b>Remark</b> <b>Standard delivery includes:</b> <b>3 m</b> cable with metal flexible tube <b>12 pole</b> Amphenol connector (for DI, DS) <b>9 pole</b> Contact connector (for SI) or <b>7 pole</b> Amphenol connector (for DO)</p>			

**Iskra Tela** d.d.

Savska cesta 3, 1000 Ljubljana, SLOVENIA  
Phone: ++386-1-4733196, Fax: +386-1-4375516  
E-Mail: info@iskra-tela.si, www.iskra-tela.si