

# FASTERCNC CO., LTD.

FASTERCNC CO., LTD.  
DDREAMCNC CO., LTD.

USBMACH3

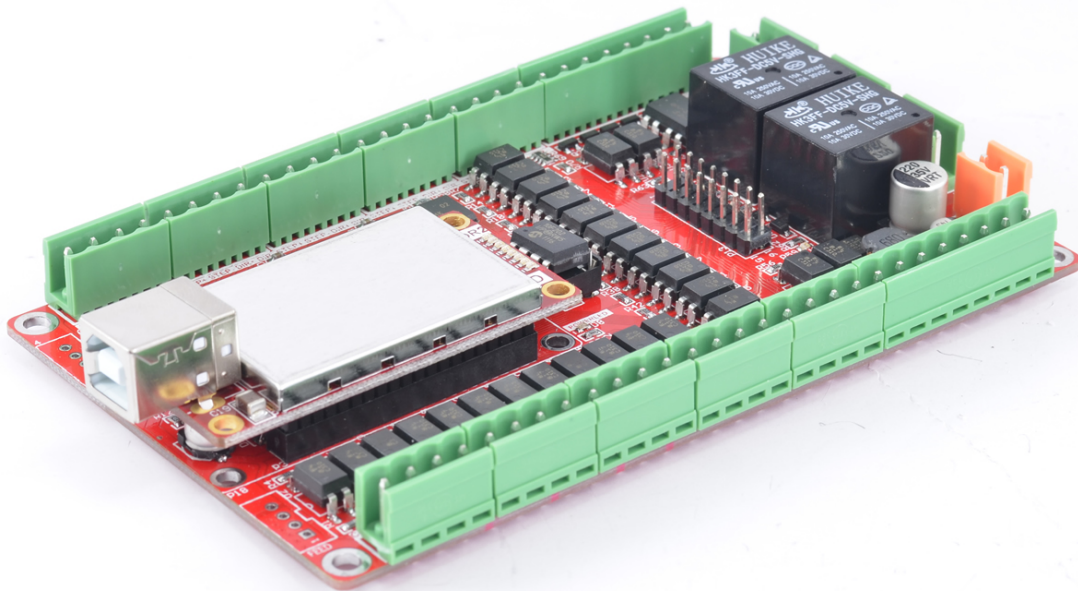

## DDUM CARD V1.0 Simple Description (English)

# C 目录 ontens

Chapter 1	Overview .....	1
1.1	Simply Introduction .....	1
1.2	Requirements of Computer .....	1
1.3	Appearance and size of product .....	2
1.4	Notes and Cautions .....	4
Chapter 2	Detailed Features .....	5
2.1	Electrical parameters.....	5
2.2	Functions and define of each module .....	5
Chapter 3	Software Installation .....	10
3.1	MACH3 Install .....	10
3.2	MACH3 Registration.....	13
3.3	USBPlug-in installation .....	13
Chapter 4	Software uses .....	14
4.1	Open Software .....	14
4.2	Software Common settings.....	15
Chapter 5	Q& A .....	19

# Chapter 1 Overview

## ▶ 1.1 Simply Introduction

DDUMV1.0X is designed by our Studio,it is a CNC system based mach3.You do not need to add other Hardware, and you can complete the signal conversion from the G-code to the movement of the stepper motor drive control. This card is compatible with most stepper drives and servo drives. And it is perfect weapon to replace mach3 parallel interface board.

## ▶ 1.2 Requirements of Computer

Basic Configuration:

- 1) CPU: 1GHz;
- 2) Memory: 512MB
- 3) 500MB Available disk space
- 4) USB 2.0

Recommended configuration:

- 1) CPU: 2GHz Dual Core;
- 2) Memory: 2GB;
- 3) 1G Available disk space
- 4) USB 2.0

▶ 1.3 Appearance and size of product

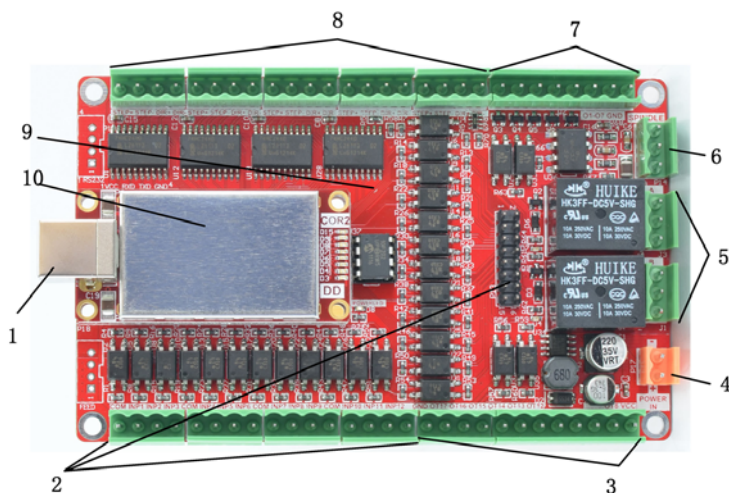

- 1、USB communication interface, and power supply for the board;
- 2、26 IO input, opto-isolated ,

It Can be configured to limit the emergency stop and other functions, 12 of them are 2edg port, 14 of them are 2.54mm are standard double-Pin port;

- 3、High 8 IO outputs;
- 4、Power input with 12~36VDC, The power supply only to optocoupler and relay;
- 5、2 Relays output port;
- 6、Spindle control output with Change from 0 to 10V by software;
- 7、 Low 8 IO outputs, O1-O5are set as Open drain.They can driver Equipment within 100mA current;
- 8、5 axis stepper driver signal output, Remarks: 4axis card's B axis is invalid, 3axis card's A&B axis are invalid;
- 9、The board Size is 127\*78mm
- 10、Use ARM7 of ATMEL as a Master and communication Chip.and Use FPGA as a Interpolation Chip;

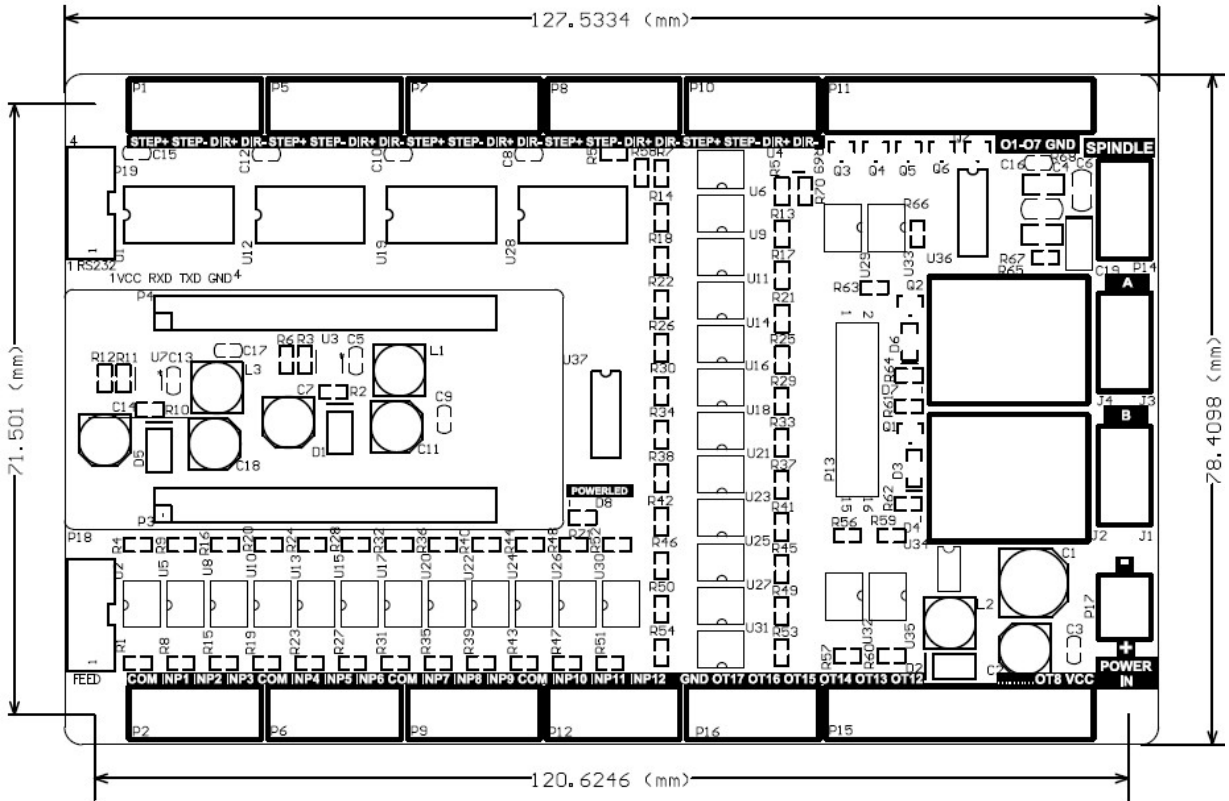

Figure1-1. Product Outline

See as Figure, Product size is 127.5\*78.4mm, Product positioning holes size is 120.6\*71.5mm.

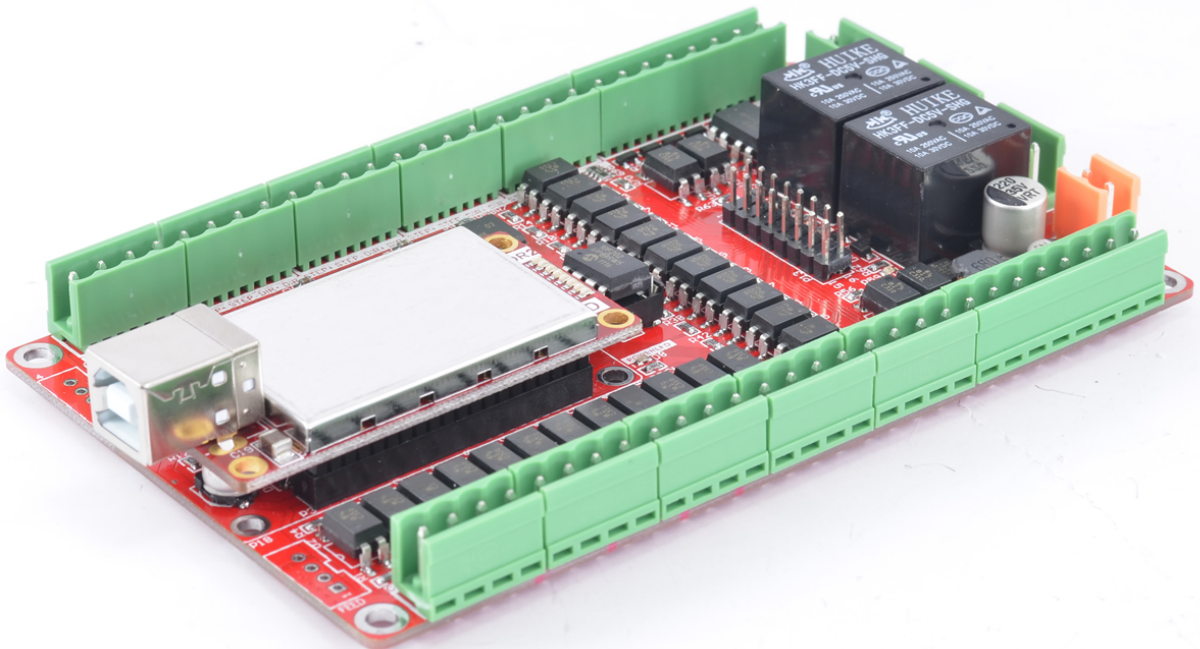

Figure1-2. Overall appearance



Figure1-3. Closeup 1 Master chip

## ▶ 1.4 Notes and Cautions



- Prohibits the rain, boards for high-performance precision equipment, rain can cause short-circuit



- CAUTION WARNING, various wiring in strict accordance with installation Description document specification.



- High risk, boards need to stay away from high-pressure.

# Chapter 2 Detailed Features

## ▶ 2.1 Electrical parameters

- A. System input voltage: 15~36V;
- B. Operating voltage of input interface: 5V;
- C. Operating voltage of output interface: 5V;
- D. stepper motor control signal output voltage: 5V;



**NOTE:** The marked as “Power In” is Power input interface, you should connected correctly.

## ▶ 2.2 Functions and define of each module

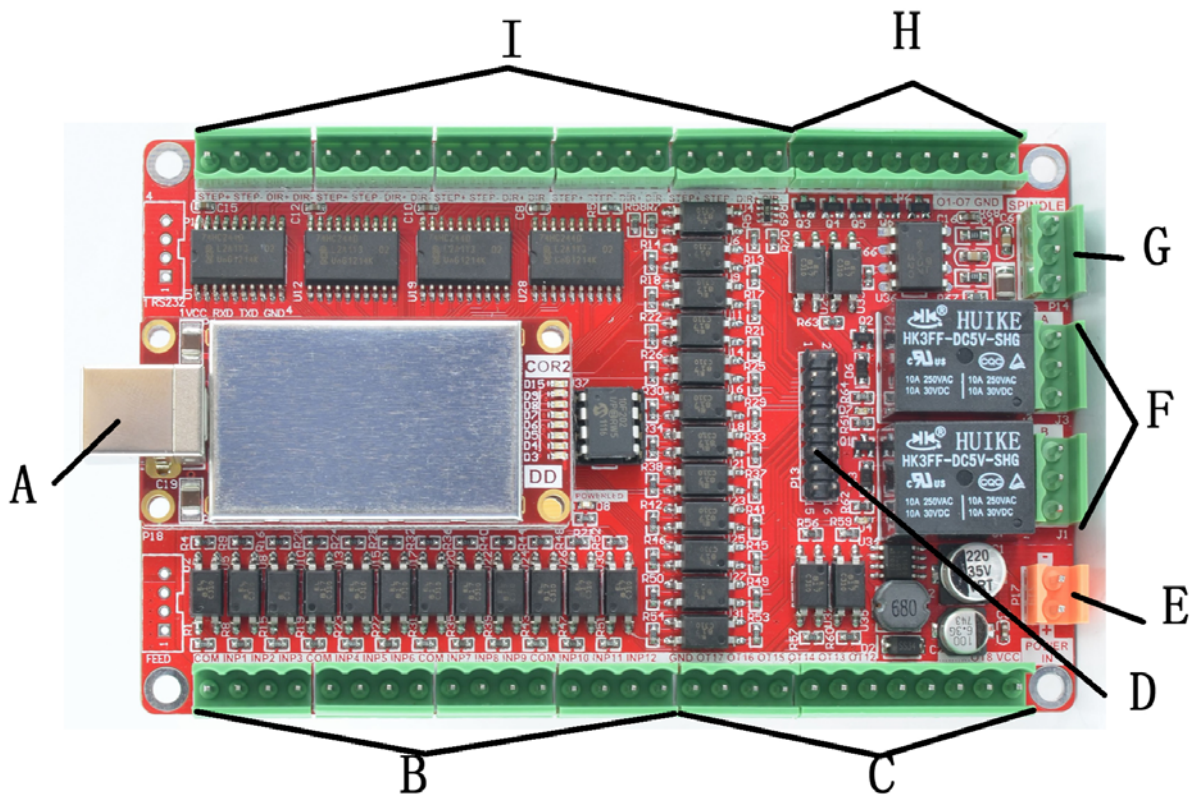

Figure2-1. Functional modules defined in Figure

- A) USB PORT, This interface is connected to the computer through a USB line. You can use the software mach3 to control this board, Note that you should use a USB2.0 cable with shielding and ferrite core, and cable length should be not more than 2 meters.
- B) 5V General INPUT PORT, IN1-12, see as Figure 2-2, it is defined as COM, IN1, IN2, IN3, COM, IN4, IN5, IN6, COM, IN7, IN8, IN9, COM, IN10, IN11, IN12 from left to right, The interface uses opto-isolated, using common positive input, COM is used as the common Port. Wiring methods see as Figure 2-2.

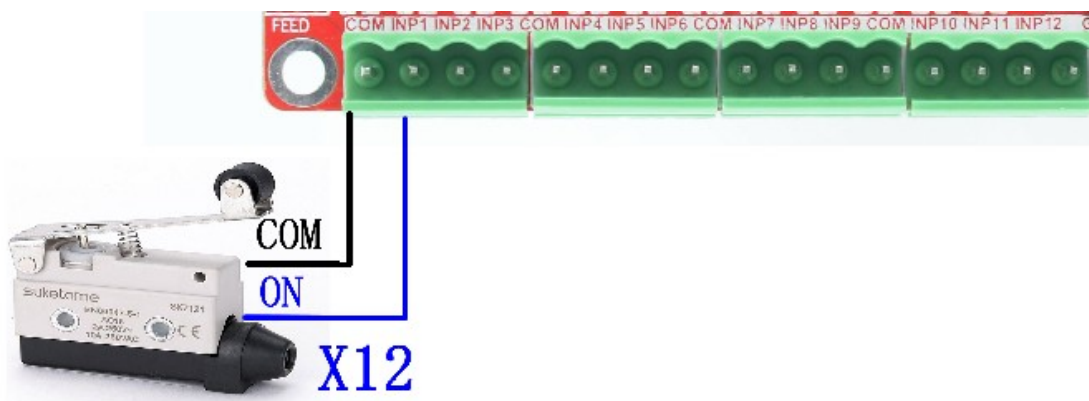

Figure2-2. normal Tact limit switch connection

- C) High 8 General IO output interface, Have a current drive capability within 10MA, defined as GND O17, O16, O15, O14, O13, O12, O11, O10, O9, O8, 5V from left to right. See as figure2-3.



Figure2-3. High 8 General IO output interface

- D) 5V General INPUT PORT IN13-IN26, it's a 2.54mm double pin port. See as Figure 2-1 The first left Pin is Pin1, PIN1-PIN16 are set as Figure2-4.

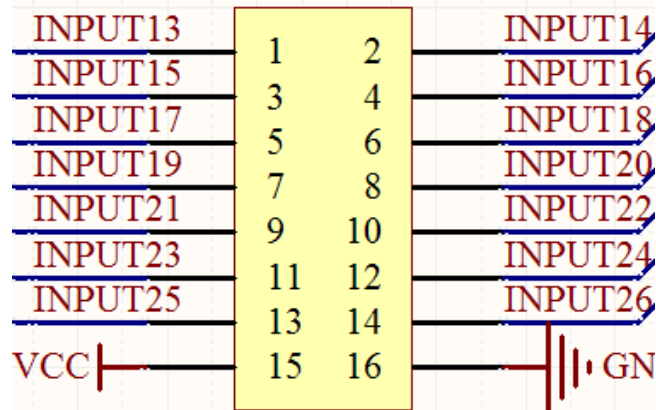

Figure2-4. 5V General INPUT PORT IN13-IN26

- E) The Yellow input terminals is power input within 15~36VDC. See as Figure2-1,the up terminal is Positive and the bottom terminal is Negative.
- F)2 Relay Output, Relay R1 and R2 are set as O18 and O19 in mach3, Each relay's 3 Terminal are CLOSE\COM\OPEN from up to down, see as Figure 2-1.
- G) **Spindle PWM speed port**, The interface requires a reference voltage, eg.10V, The port is set as 10VIN 0-10Vout,GND from up to bottom. See as Figure 2-5.



Figure2-5. Spindle PWM speed port

- H) Low 8 General IO output interface, Have a current drive capability within 10MA, defined as O1、O2、O3、O4、O5、O6、O7、GND from left to right.O1-O5 are Open drain port. The Maximum drive current up to 100MA, Wiring methods see as Figure2-6.

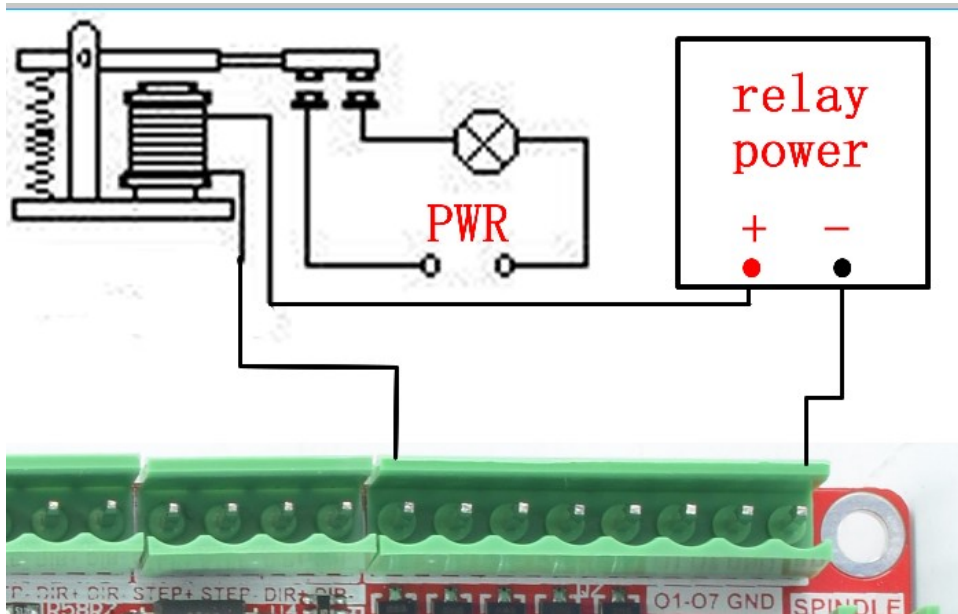

Figure2-6. Open drain port Wiring methods of O1-O5

- I) 5-axis stepper motor control signal output, defined as CK+\CK-\DIR+\DIR-. There are positive pulse, negative pulse, positive direction, negative direction. These ports are common positive connections. Therefore, on the board CK + and DIR + are linked together to 5V. So this board does not support the common negative connection. Wiring method refer to Figure 2-7. This card doesn't have EN signal, most drives on sale should not be connected to the EN signal. It is defined as X \ Y \ Z \ A \ B channel from left to right, see as Figure 2-1.

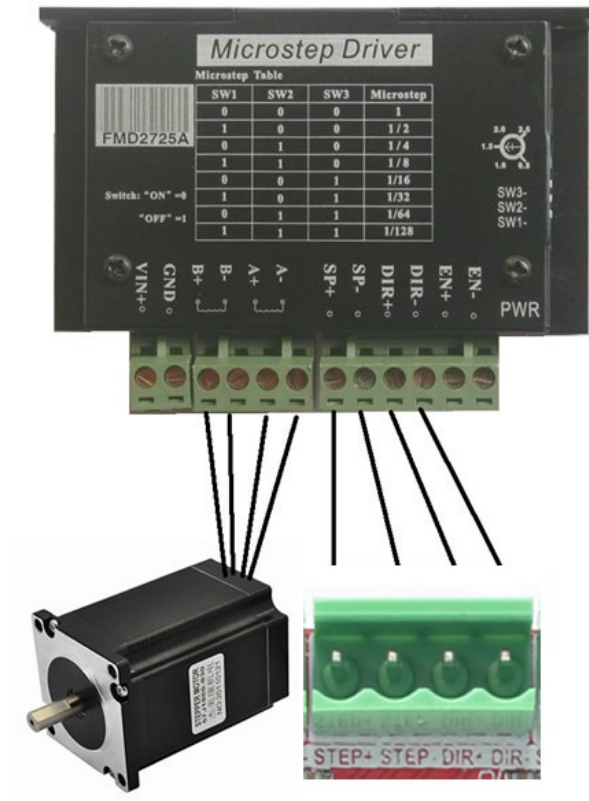

Figure2-7. Stepper motor driver connection method

## Chapter 3 Software Installation

### ▶ 3.1 MACH3 Install

When you purchase our product, we will supply a CD-ROM, which contains the MACH3 installation, registration, and USB plug-ins. See as Figure 3-1.

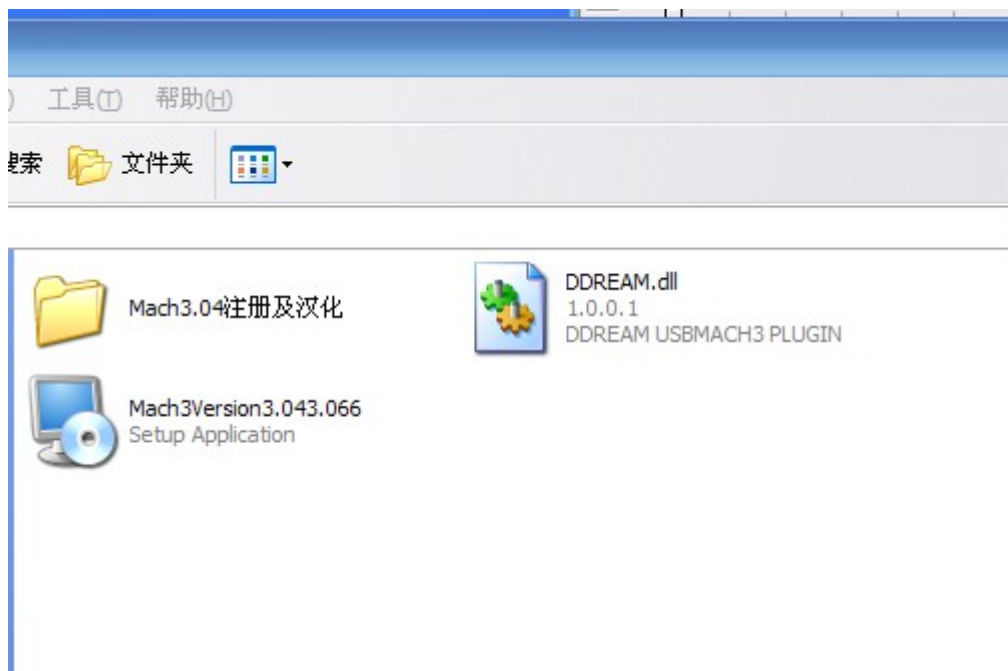
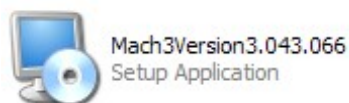

Figure 3-1. CD-ROM Screenshot

**First run the installation Mach3Version3.043.066** first page. See as Figure 3-2.



. Into the

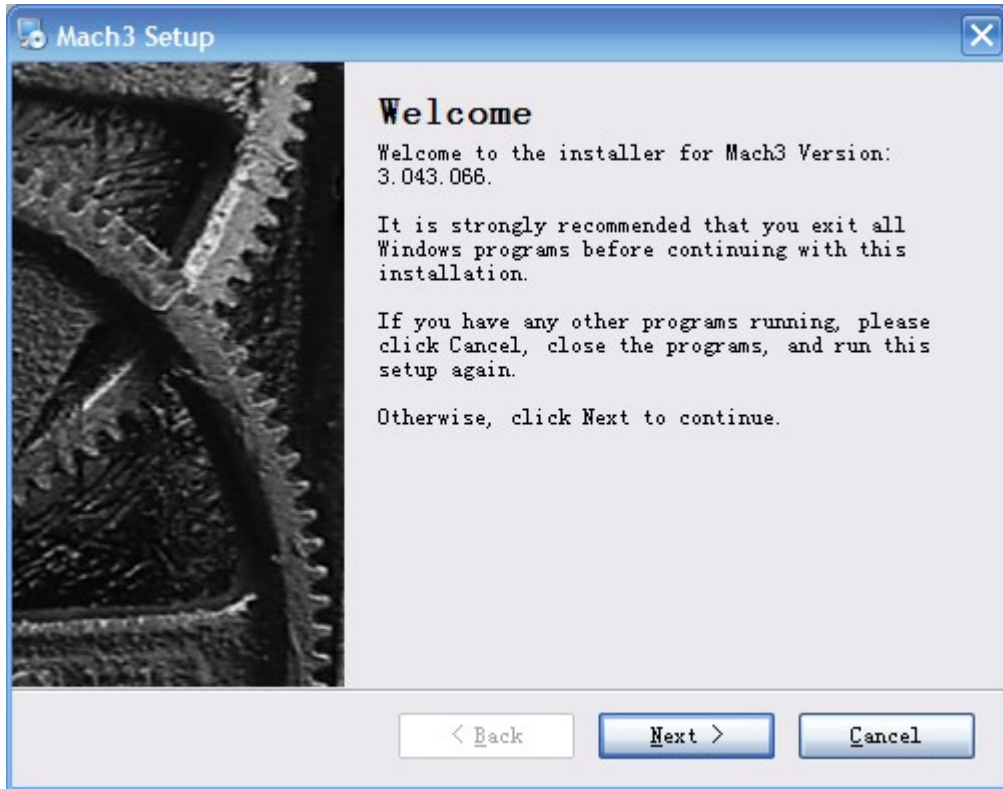

Figure 3-2. MACH3 installation process 1

Click Next and then enter the page shown in Figure 3-3.

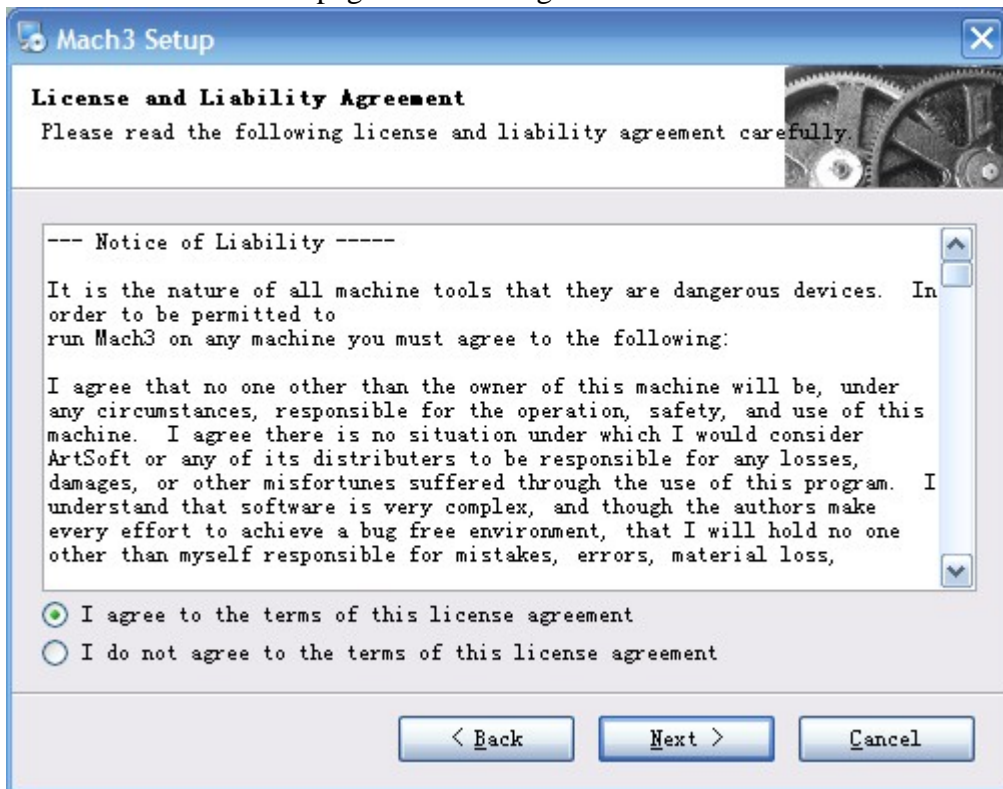

Figure 3-3. MACH3 installation process 2

Select the consent agreement, click Next, See as Figure 3-4



Figure 3-4. MACH3 installation process 3

Select the installation path, click Next (it can be installed on any disk, and recommended to install the C drive or the D drive) See as Figure 3-5



Figure 3-5. MACH3 installation process 4

Click Next until completion. Then restart the computer.

### ▶ 3.2 MACH3 Registration

Copy the file Mach1Lic.dat in The CD-ROM to mach3 installation path (eg C :/ MACH3) .

### ▶ 3.3 USBPlug-in installation

Copy the file DDREAM.dll



DDREAM.dll  
1.0.0.1  
DDREAM USBMACH3 PLUGIN

to X:\Mach3\PlugIns.

# Chapter 4 Software uses

## ▶ 4.1 Open Software

- Double-click the mach3mill



Enter mach3 software. Pop-up the plug-in dialog box. See as Figure 4-1.

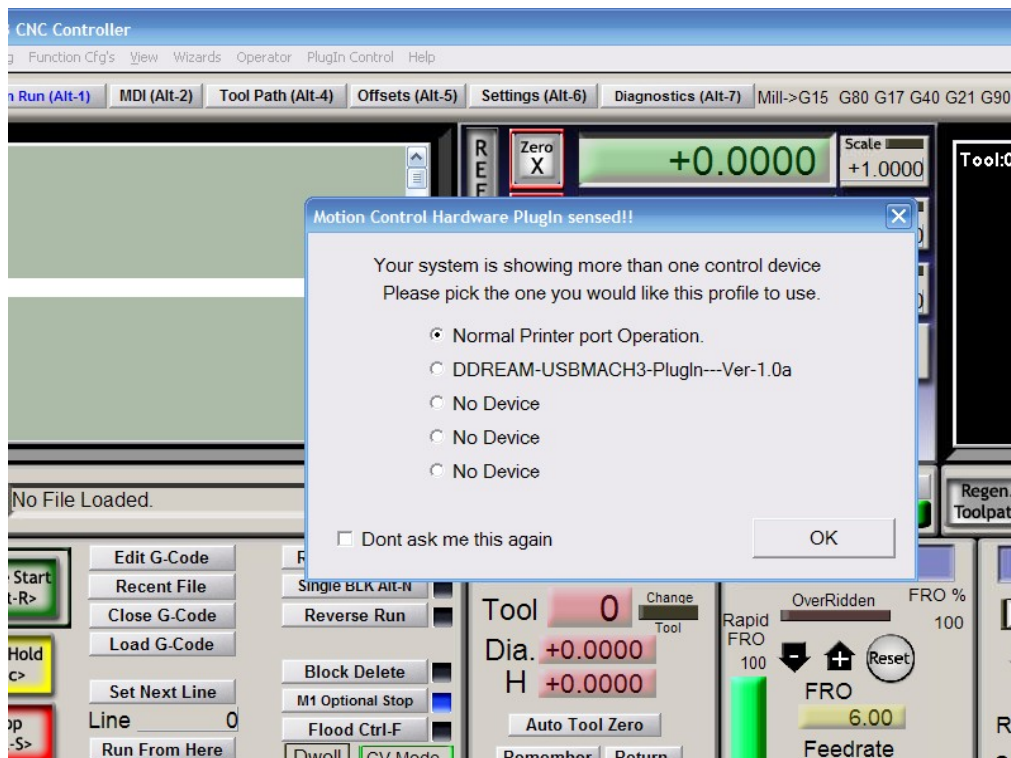

Figure4-1. Plugin selection dialog

Choose our plugin DDREAM-USBMACH3-PlugIn---Ver-1.0a. Then press OK. If you do not want the dialog box pop up again next time, you can select Don't ask me this again. If USBmach3 interface board is not properly connected, or other connection fails, the dialog box in Figure 4-2 will appear, Please re-connected properly USBmach3 interface board or contact sales.



Figure4-2. Not connected correctly

▶ 4.2 Software Common settings

■ DDUM plugin setting

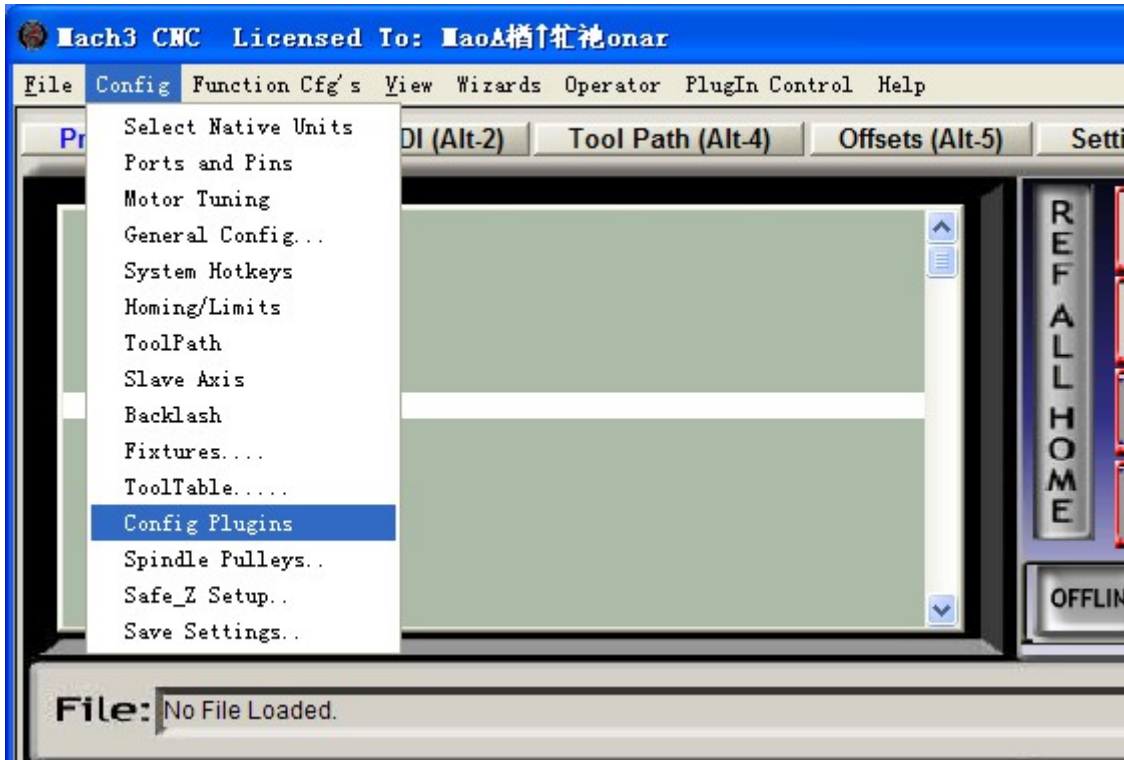

Figure4-3. get in config plugins

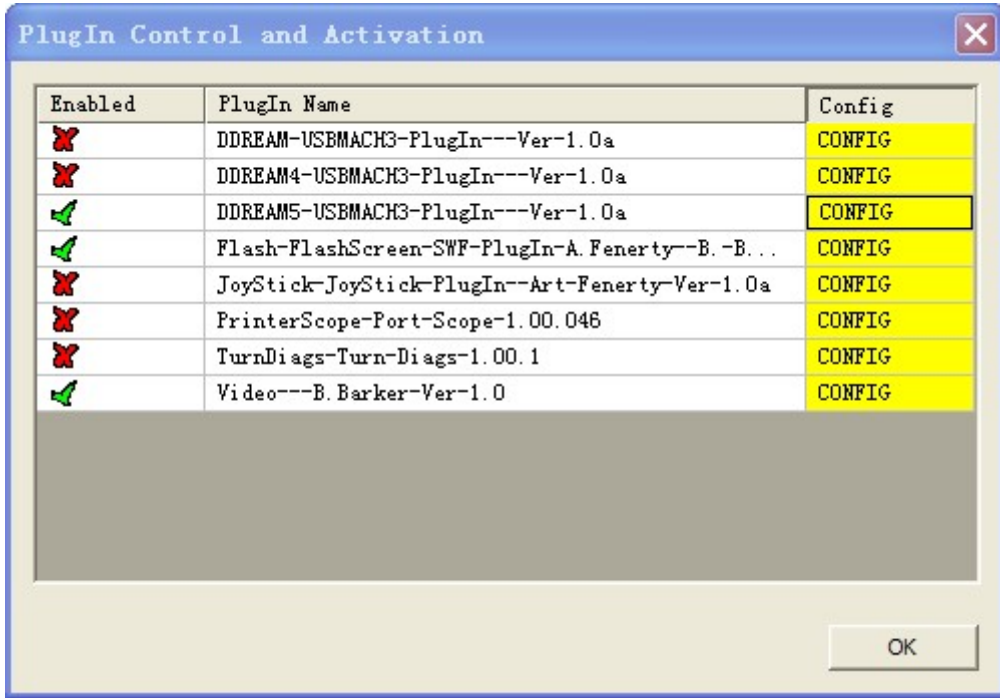

Figure4-4. click config

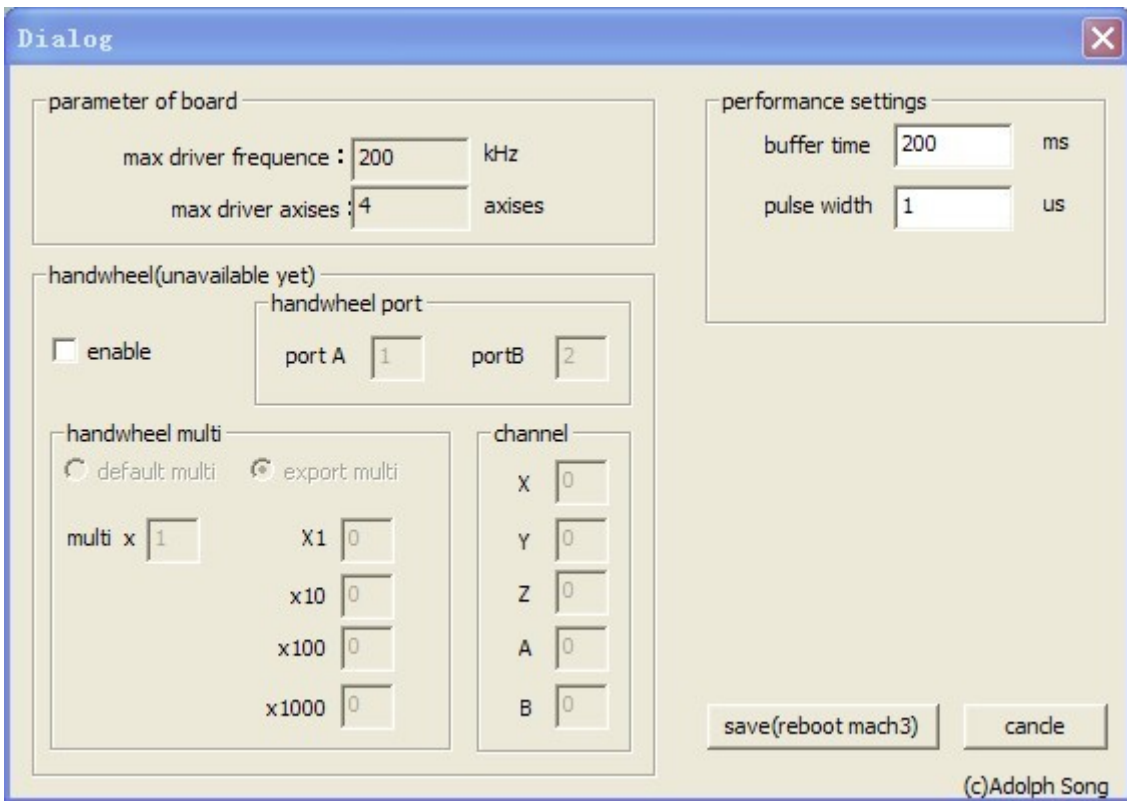

Figure4-5. config dialog

In this dialog you can change buffer time and plus width. If buffer time is too short,the system will be unstable,or if buffer time is too long,the system's delay will be long. The default setting is 200ms buffer time and 1us pulse width.

■ Motor operating parameters setting

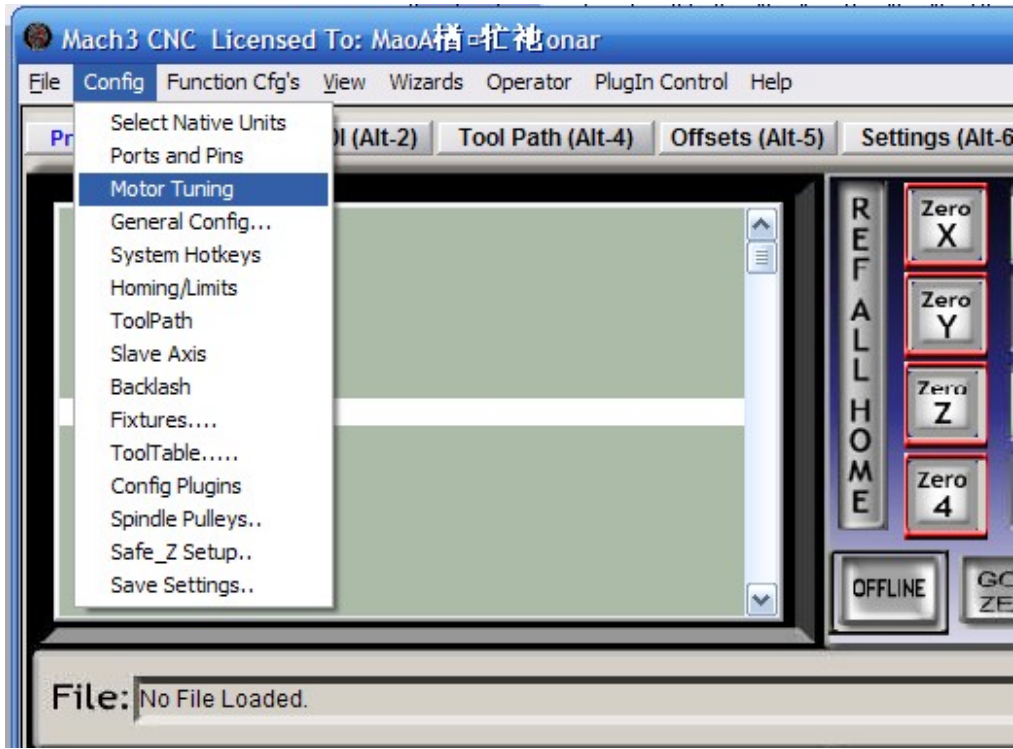

Figure4-6. Motor operating parameter setting menu entry

See as Figure 4-3. From submenu “motor tuning” of the menu “config” into the motor parameter settings dialog. See as Figure 4-4.

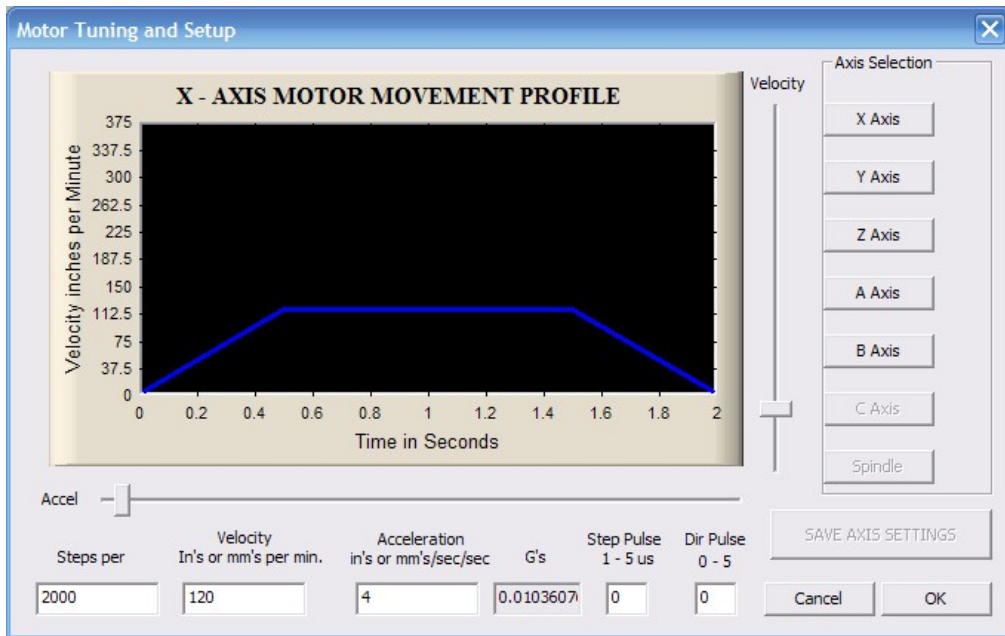

Figure4-7. Motor operating parameter settings dialog

The parameters are defined as follows:

**Steps per:** Pulse equivalent ,it is number of pulses required with axial movement 1mm, This can be calculated by lead screw pitch and motor drive segment. Such as pitch 2.5mm,2-phase motor 8 segments, Calculation method is  $8 \times 200 / 2.5 = 640$ 。

**Velocity:** The speed is the axial velocity, Units is mm/s, Recommended settings 1500.

**Acceleration:** Units is mm/s<sup>2</sup>, Recommended settings 200.

**Step Pulse:** Minimum pulse width,Recommended settings 2.

**Dir Pulse:** Minimum width direction, Recommended settings 2.

**Attention:**The parameters for each axis is not necessarily the same, To select the axis, and then set parameters. You should click “SAVE AXIS SETTINGS” After setting.

## ■ Port Settings

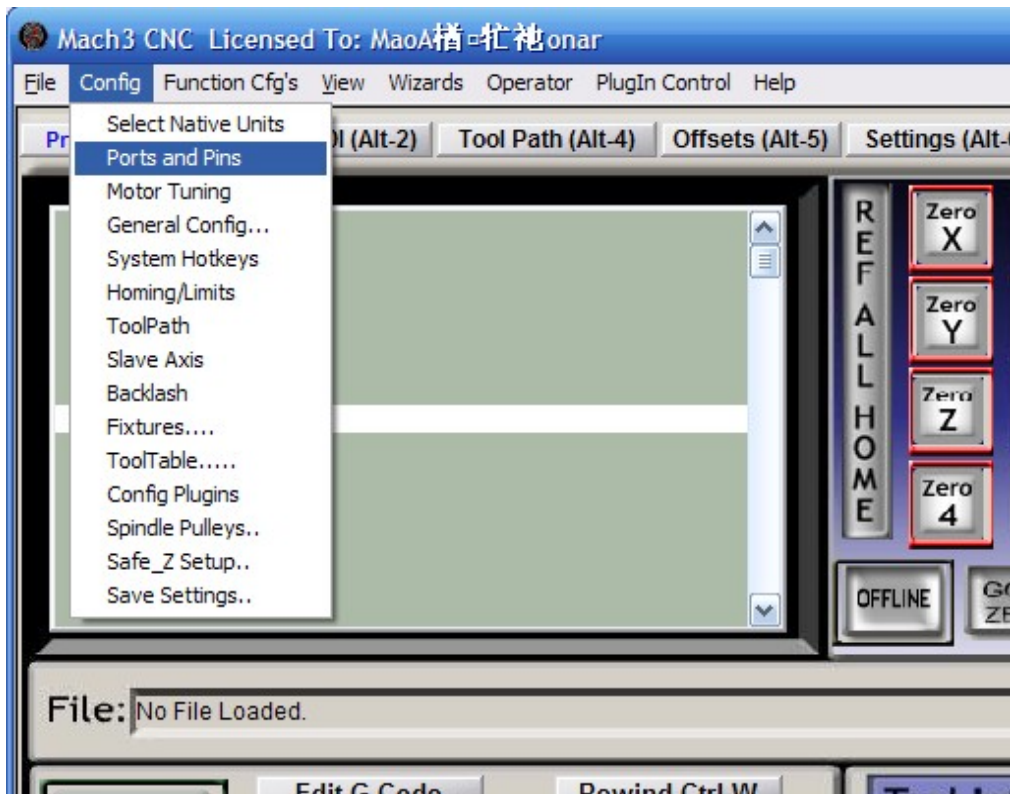

Figure4-8. Port settings

See as Figure 4-5, Click the sub-menu “ports and pins” of menu “Config” into Port Settings dialog box.

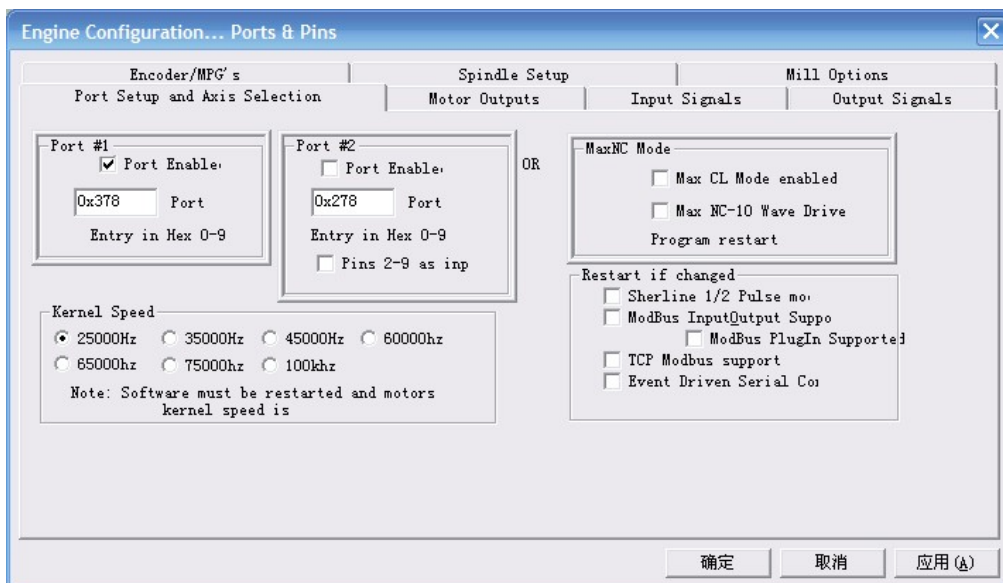

Figure4-9. Port Settings dialog box

The sub-pages you need to set include “Motor Outputs”, “Input Signals”, “Output Signals” and “Spindle Setup”. First Click to enter “Motor Outputs”. This page is to select the stepper motor control pin. Because our usbmach3 interface board stepper motor signals are fixed, So here only need to Select, no need to select the specific pin. See as Figure4-7

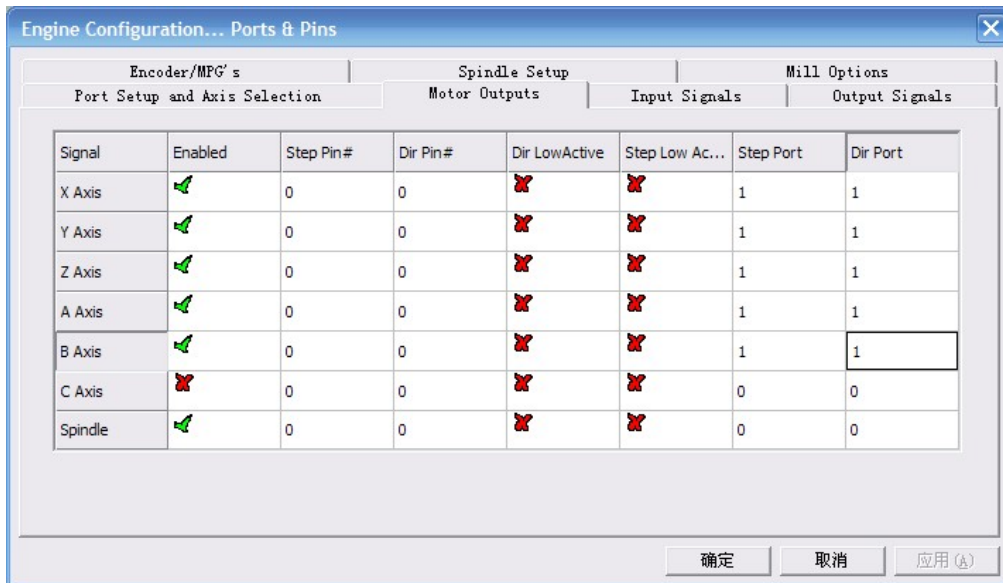

Figure4-10. Stepper motor port settings dialog

Click “Input Signals” into the input signal settings page. See as Figure4-8

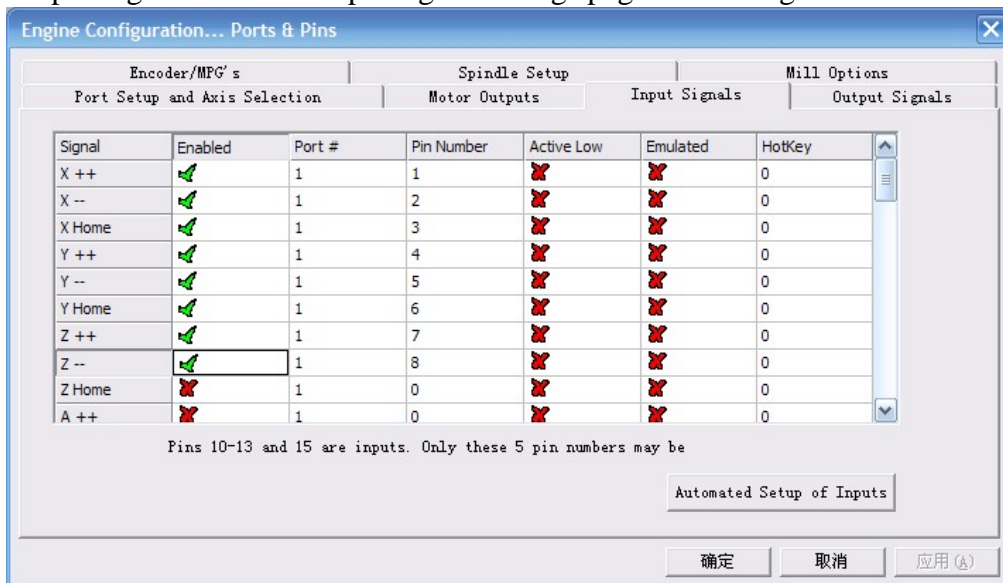

Figure4-11. IO Input Settings dialog box

Here you can configure according to your actual needs the corresponding function. Optional Function include XYZAB5axis's Upper and lower limit、XYZAB5axis's HOME point、PROBE、ESTOP, etc. The board has 20 input signals in total, Numbers followed 1-20, Customers can choose according to their needs, in accordance with the pin numbers, define the corresponding function.

Click “Output Signals” to enter the Output signal setting page. See as Figure 4-9

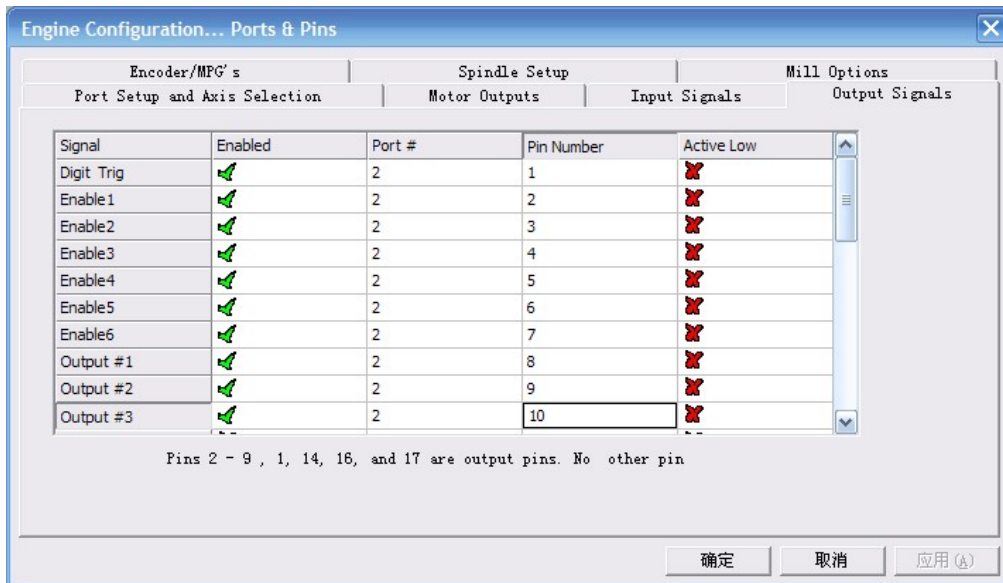

Figure4-12. Output Signal Setup dialog

Note that the output signal number from 1-16. Because there is an overlap with the input signal, We set output signals to the port 2. See as Figure4-9, PORT # All output signal is set to 2. Please put Output signal to the corresponding options as you need.

Click “Spindle Setup” switch to the spindle settings page. See as Figure4-10.

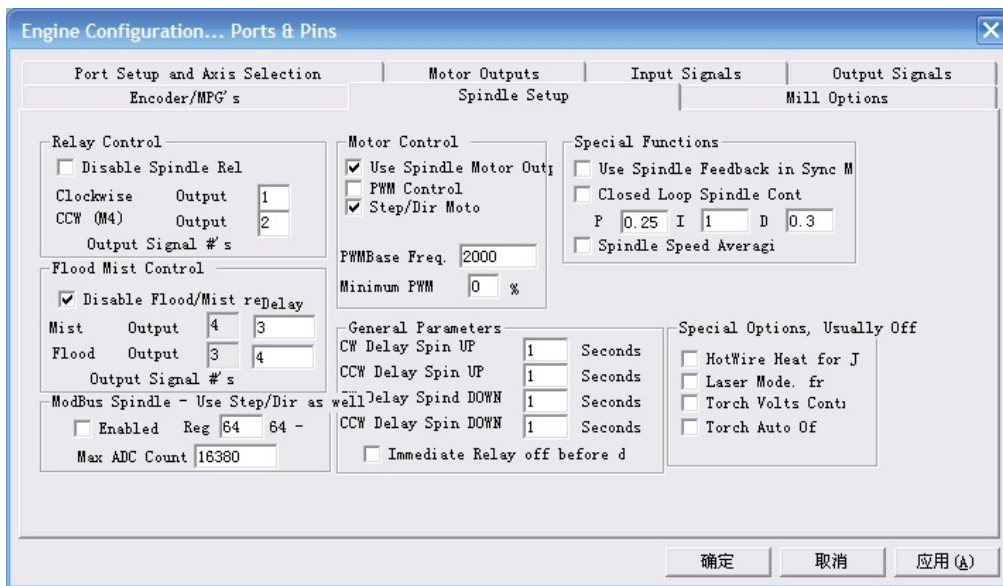

Figure4-13. Spindle Settings dialog box

Here we can configure the spindle rotates CW、Reverse CCW、Mist、Flood pin, See as Figure4-10, They have been configured as 1、2、3、4. Corresponding to output#1~output#4 in Figure4-11.output#1~output#6 in Output Signal Setup dialog can be Configured into these 4 signals. Here we note correspondence between 2 page. Please select “use spindle motor output” if required PWM speed spindle. And select “ PWM Control”. Our PWM pin fixedly arranged on board OUTPUT20 pin, it’s no need to set.

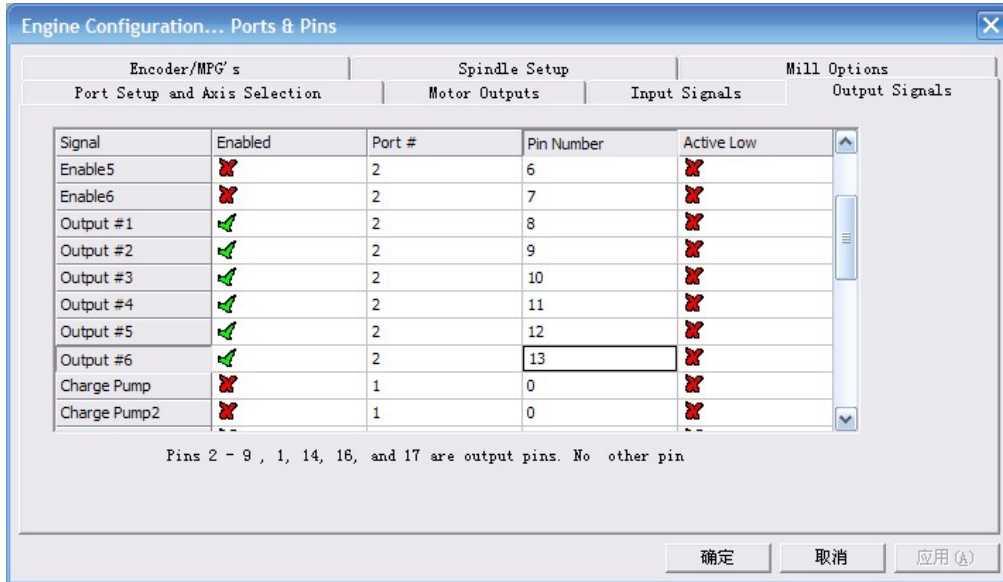

Figure4-14. Spindle setting corresponds to the output configuration

## **Chapter 5** **Contact us and Q& A**

- Company Website: [ddcnc.com](http://ddcnc.com);
- Technical Support email: [649631655@qq.com](mailto:649631655@qq.com);
- Technical Support qq: 649631655;