



DS2 series servo drive

User manual

Xinje Electronic Co., Ltd.

Serial No. SC02 20101119 1.0

All copyrights reserved by Xinje Electronic Co., Ltd.

Any copying, transferring or any other usage is prohibited. Otherwise Xinje will have the right to pursue legal responsibilities. All rights including patent and permission of modules and designs are reserved.

January, 2010

Safety Precautions

Be sure to review this section carefully before use this product. In precondition of security, wire the product correctly.

The following defines the symbols used in this manual to indicate varying degrees of safety precautions and to identify the corresponding level of hazard inherent to each. Failure to follow precautions provided in this manual can result in serious, possibly even fatal, injury, and/or damage to the persons, products, or related equipment and systems.



CAUTION

Indicates a potentially hazardous situation, which, if not heeded, could result in death or serious injury



WARNING

Indicates a potentially hazardous situation, which, if not avoided, may result in minor or moderate injury.

● Checking Products upon Delivery



CAUTION

1. DO NOT install any driver which is damaged, lack of accessories or not the same with the model ordered.
Doing so may result in electric shock.

● Installation



WARNING

1. Cut off external power supply before installation.
Not doing so may result in electric shock.



CAUTION

1. Always use the servomotor and servo amplifier in one of the specified combinations.
Never use the products in an environment subject to water, corrosive gases, inflammable gases, or combustibles.
Doing so may result in electric shock, fire or malfunction.
2. DO NOT touch any metallic part.
Doing so may result in malfunction.

● Wiring



WARNING

1. Cut off external power supply before wiring.
Not doing so may result in electric shock.
2. Connect AC power supply to the corresponding terminals.
Faulty wiring may result in fire.



CAUTION

1. Do not connect a three-phase power supply to the U, V, or W output terminals.
Doing so may result in injury or fire.
2. Use 2mm² wire to grounding the ground terminals.
Not doing so may result in electric shock.
3. Securely fasten the power supply terminal screws and motor output terminal screws.
Not doing so may result in fire.

● Operation



WARNING

1. Never touch any rotating motor parts while the motor is running.
Doing so may result in injury.
2. DO NOT touch the inside the driver.
Doing so may result in electric shock.
3. Do not remove the panel cover while the power is ON.
Doing so may result in electric shock.
4. Do not touch terminals for five minutes after the power has been turned OFF.
Residual voltage may cause electric shock.



CAUTION

1. Conduct trial operation on the servomotor alone with the motor shaft disconnected from machine to avoid any unexpected accidents.
Not doing so may result in injury.
2. Before starting operation with a machine connected, change the settings to match the parameters of the machine.
Starting operation without matching the proper settings may cause the machine to run out of control or malfunction.
3. Before starting operation with a machine connected, make sure that an emergency stop can be applied at any time.
Not doing so may result in injury.
4. Do not touch the heat sinks during operation.
Not doing so may result in burns due to high temperatures.
5. Do not attempt to change wiring while the power is ON.
Doing so may result in electric shock or injury

Catalog

Preface.....	I
1 Checking Product and Part Names	2
1-1. Checking Products on Delivery	2
1-1-1. Servomotors.....	2
1-1-2. Servo Drivers	3
1-1-3. Adaptation table of servo drive and motor	4
1-2. Product Part Names.....	4
1-2-1. Servomotors.....	4
1-2-2. Servo Drivers	5
2-1. Servomotor	7
2-1-1. Storage Temperature	7
2-1-2. Installation Site	7
2-1-3. Concentricity.....	7
2-1-4. Orientation	8
2-1-5. Handling Oil and Water	8
2-1-6. Cable Stress	8
2-2. Servo Drivers.....	8
2-2-1. Storage Conditions	8
2-2-2. Installation Site	8
2-2-3. Orientation	9
2-2-4. Installation	9
3 Wiring	11
3-1. Main Circuit Wiring.....	11
3-1-1. Names and Descriptions of Main Circuit Terminal.....	11
3-1-2. Typical Wiring Example	12
3-1-3. Winding Terminals on Servo motor.....	13
3-2. I/O Signals	13
3-2-1. Layout of CN0/CN1 Terminals	13
3-2-2. CN0 and CN1	13
3-2-3. I/O Signal Names and Functions	15
3-2-4. Interface Circuits.....	15
3-3. Wiring Encoders	17
3-3-1. Encoder Connections.....	17
3-3-2. CN2 Encoder Connector Terminal Layout.....	18
3-4. Standard connection examples	18
3-4-1. Position Control Mode	19
3-5. Communication Port	21
3-5-1. Serial Port 1(COM1).....	21
3-5-2. Serial Port 2(COM2).....	22
3-6. Regenerative Resistor.....	22
4 Use the operate panel.....	24
4-1. Basic Operation.....	24
4-1-1. Functions of operate panel.....	24
4-1-2. Basic Mode Switching	24

4-2.	Running status mode	25
4-3.	Monitoring Mode	26
4-4.	Auxiliary Function	28
4-4-1.	Check System Information	29
4-4-2.	Auxiliary Run Mode	29
4-4-3.	Change the motor type	30
4-4-4.	Check Alarm Information	31
4-4-5.	Reset Parameters to Default	31
4-4-6.	External monitoring	31
4-5.	Parameter Setting	31
4-6.	Alarm	32
5	Run the servo system	33
5-1.	Control mode selection	33
5-2.	Basic function setting	33
5-2-1.	Servo ON setting	34
5-2-2.	Switch the motor rotate direction	34
5-2-3.	Overtravel Limit (P-OT & N-OT)	34
5-2-4.	Motor stop mode when servo OFF	36
5-2-5.	Power-off Brake (BK)	36
5-3.	Position mode (external pulse command)	38
5-3-1.	Control mode selection	39
5-3-2.	Pulse command	39
5-3-2-1.	Pulse mode selection	39
5-3-2-2.	Explanation of command pulse	39
5-3-2-3.	Signal connection	40
5-3-3.	Electronic gear ratio	40
5-3-3-1.	Parameter	40
5-3-3-2.	Set the electronic gear	40
5-3-3-3.	Example of setting the electronic gear	41
5-3-4.	Position command filter	41
5-3-5.	Pulse error clear (/CLR)	42
5-3-6.	Positioning complete (/COIN)	42
5-3-7.	Positioning near (/NEAR)	43
5-3-8.	Command pulse prohibition (/INHIBIT)	43
5-4.	Position mode (internal position mode)	44
5-4-1.	Control mode selection	44
5-4-2.	Internal position given mode	44
5-4-3.	Position parameters from segment 1 to 16	47
5-4-4.	Change step (/CHGSTP)	47
5-4-5.	Pause current signal (/INHIBIT)	47
5-4-6.	Skip current signal (/ZCLAMP)	48
5-4-7.	Reference origin	48
5-5.	Speed control (analog voltage command)	50
5-5-1.	Control mode selection	50
5-5-2.	Analog value of rated speed	50
5-5-3.	Speed command offset auto-adjustment (F1-03)	51
5-5-4.	Proportion action command (/P-CON)	51
5-5-5.	Zero clamp (/ZCLAMP)	51
5-5-6.	Speed coincidence checking (/V-CMP)	52
5-5-7.	Torque limit	52
5-5-7-1.	Internal torque limit (output torque max value limit)	52

5-5-7-2. External torque limit (via input signal)	52
5-5-7-3. External torque limit (via analog voltage command)	53
5-5-7-4. External torque limit (via external input + analog voltage)	53
5-5-7-5. Output torque up to limit value signal	54
5-5-8. Soft start	54
5-5-9. Filter	54
5-5-10. Speed command input dead voltage.....	55
5-6. Speed control (internal speed)	55
5-6-1. Control mode selection.....	56
5-6-2. Internal speed setting.....	56
5-6-3. Input signal setting.....	56
5-7. Speed control (pulse frequency command).....	57
5-7-1. Control mode selection.....	58
5-7-2. Pulse frequency command.....	58
5-7-3. Command pulse frequency at rated speed.....	58
5-7-4. Speed command pulse filter time.....	58
5-8. Torque control (analog voltage command)	58
5-8-1. Control mode selection.....	59
5-8-2. The analog value of rated torque	59
5-8-3. Torque command offset autoadjustment (F1-04)	59
5-8-4. Torque command filter time	59
5-8-5. Torque limit	60
5-8-5-1. Internal speed limit	60
5-8-5-2. External speed limit	60
5-8-5-3. Speed up to limit value output.....	60
5-8-6. Torque command input dead area voltage	60
5-9. Torque control (internal setting).....	61
5-9-1. Control mode selection.....	61
5-9-2. Internal torque command.....	61
5-10. Switch the control mode.....	61
5-11. Other output signals	62
5-11-1. /ALM and /ALM-RST	62
5-11-2. /WARN.....	62
5-11-3. Rotation checking (/TGON)	62
5-11-4. Servo ready (/S-RDY).....	62
5-11-5. Encoder Z phase output (/Z).....	63
5-11-6. AB phase feedback signal of encoder	63
5-12. I/O signal distribution	63
5-12-1. Input signal distribution.....	63
5-12-2. Default setting of input terminal.....	64
5-12-3. Output terminal distribution	65
5-12-4. Default setting of output terminal	65
6 Servo gain adjustment.....	66
6-1. Servo gain setting.....	66
6-1-1. Gain setting of speed loop	66
6-1-2. Gain setting of position loop.....	66
6-1-2-1. Position loop proportion gain	66
6-1-2-2. Position loop feedforward gain.....	67
6-1-3. The experience of parameter adjustment.....	67
6-1-4. Proportion action command (P-CON).....	67
6-1-5. Gain switch (G-SEL).....	68

7 Specification and dimension	69
7-1. Servo motor	69
7-1-1. Servo motor specification.....	69
7-1-2. Torque-Speed Feature	71
7-1-3. Servo motor dimensions.....	72
7-2. Servo drivers.....	75
7-2-1. General specification.....	75
7-2-2. Performance specification	76
7-2-3. Servo driver dimensions.....	77
8 Alarm Information	79
Appendix 1 Parameter list.....	81
Appendix 2 Application.....	87



Preface

This chapter describes the constitution of this manual, the intended user, and how to acquire this manual.

Constitution of This Manual

This manual is divided into 7 chapters.

1. Checking Product and Part Names

This chapter describes the procedure for checking products upon delivery as well as names for product parts.

2. Installation

This chapter describes precautions for servomotor and servo driver installation.

3. Wiring

This chapter describes the procedure used to connect DS2 Series products to peripheral devices and gives typical examples of main circuit wiring as well as I/O signal connections.

4. Parameter Settings and Functions

This chapter describes the procedure for setting and applying parameters.

5. Use Digital Panel

This chapter describes the basic operation of the digital panel and the features it offers.

6. Ratings and Characteristics

This chapter provides the ratings, torque-speed characteristics diagrams, and dimensional drawings of the DS2 series servo drives and MS series servomotors.

7. Alarm Information

This chapter describes the alarm information of DS2 series servo drivers.

Intended User

This manual is intended for the following users.

- Those designing DS2 Series servodrive systems.
- Those installing or wiring DS2 Series servodrives.
- Those performing trial operation or adjustments of DS2 Series servodrives.
- Those maintaining or inspecting DS2 Series servodrives.

How to Acquire This Manual

1. Electrical Manual

- (1) Log on Xinje official website www.xinje.com to download.
- (2) Acquire this manual on a CD from an authorized distributor.

1 Checking Product and Part Names

This chapter describes the procedure for checking products upon delivery as well as names for product parts.

1-1. Checking Products on Delivery

Use the following checklist when products are delivered.

Items	Comments
Are the delivered products the ones that were ordered?	Check the model numbers marked on the nameplates of the servomotor and servo driver.
Does the servomotor shaft rotate smoothly?	The servomotor shaft is normal if it can be turned smoothly by hand. Servomotors with brakes, however, cannot be turned manually.
Is there any damage?	Check the overall appearance, and check for damage or scratches that may have occurred during shipping.
Are there any loose screws?	Check screws for looseness using a screwdriver.
Is the motor code the same with the code in driver?	Check the motor code marked on the nameplates of the servomotor and the parameter F0-00 on the servo driver.

If any of the above is faulty or incorrect, contact Xinje or an authorized distributor.

1-1-1. Servomotors

■ External Appearance

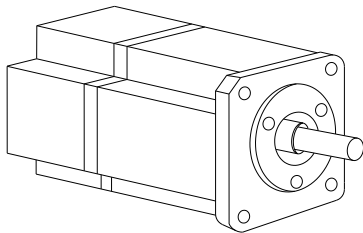

■ Nameplate

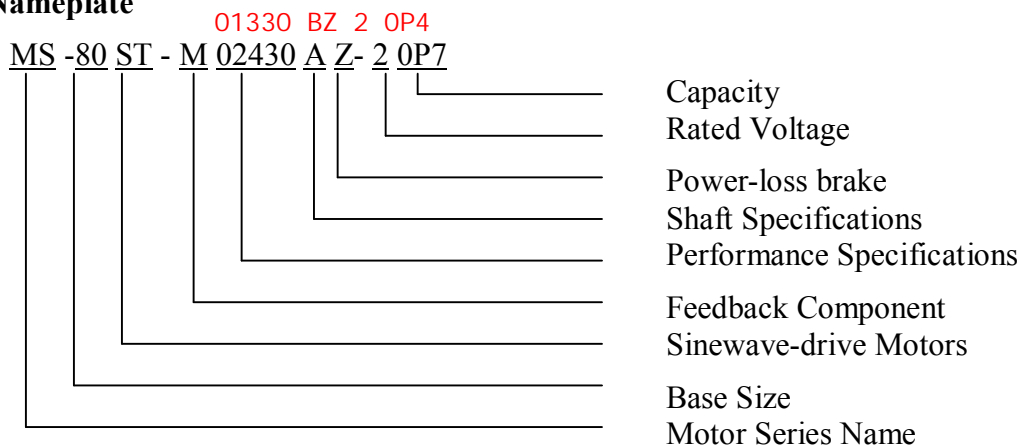

Base number	60, 80, 90, 110, 130, 180	
Feedback component no.	M	Optical pulse encoder

Performance parameter no.	First 3 bits mean rated torque, last 2 bits mean rated speed Such as: 00630: rated torque 0.6N.m, rated speed 3000rpm 06025: rated torque 6.0N.m, rated speed 2500rpm 19015: rated torque 19.0N.m, rated speed 1500rpm	
Shaft spec	A	No bond
	B	With bond
Power-loss brake	Vacant	No
	Z	With DC99V power-off brake
Voltage level	2	220V
	4	380V
Power	Such as: 0P4: 0.4kW 0P7: 0.75kW 3P0: 3.0kW	

01330



1.3 *
3000 /

1-1-2. Servo Drivers

External Appearance

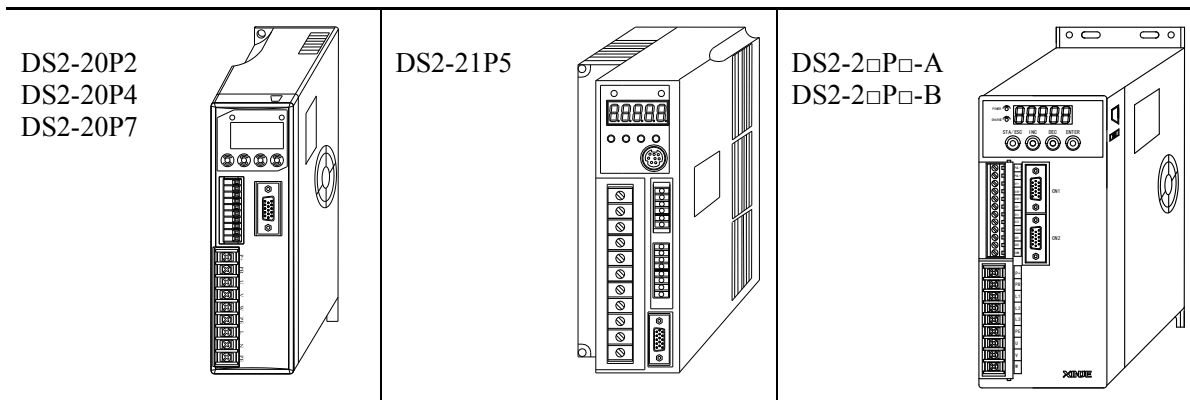

Nameplate

DS2 – 2 1P5 - A

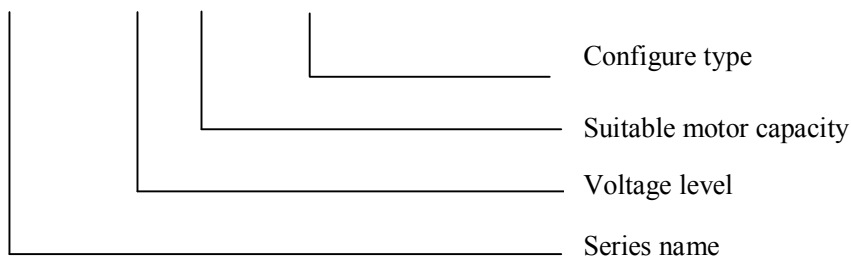

Configure type	A	Open collector mode AB phase feedback
	B	Difference mode AB phase feedback
suitable motor capacity	0P2	0.2KW
	0P4	0.4KW
	0P7	0.75KW
	1P5	1.5KW

	2P3	2.3KW
	3P0	3.0KW
Voltage level	2	220V
	4	380V

1-1-3. Adaptation table of servo drive and motor

Motor type	Motor code	Suitable drive	Voltage level
MS-60ST-M00630-20P2	0003	DS2-20P2	1-phase 220V
		DS2-20P2-A	3-phase 220V
MS-60ST-M01330-20P4	0004	DS2-20P4	1-phase 220V
		DS2-20P4-A	3-phase 220V
MS-80ST-M02430-20P7	0011	DS2-20P7	1-phase 220V
		DS2-20P7-A	3-phase 220V
MS-90ST-M02430-20P7	0021	DS2-20P7	1-phase 220V
		DS2-20P7-A	3-phase 220V
MS-110ST-M04030-21P2	0031	DS2-21P5	1-phase 220V
		DS2-21P5-A	3-phase 220V
		DS2-21P5-B	
MS-110ST-M05030-21P5	0032	DS2-21P5	1-phase 220V
		DS2-21P5-A	3-phase 220V
		DS2-21P5-B	
MS-130ST-M06025-21P5	0042	DS2-21P5	1-phase 220V
		DS2-21P5-A	3-phase 220V
		DS2-21P5-B	
MS-130ST-M10015-21P5	0044	DS2-21P5	1-phase 220V
		DS2-21P5-A	3-phase 220V
		DS2-21P5-B	
MS-130ST-M07725-22P0	0043	DS2-22P3-A	3-phase 220V
MS-130ST-M15015-22P3	0046	DS2-22P3-A	3-phase 220V
MS-180ST-M19015-23P0	0052	DS2-23P0-A	3-phase 220V

1-2. Product Part Names

1-2-1. Servomotors

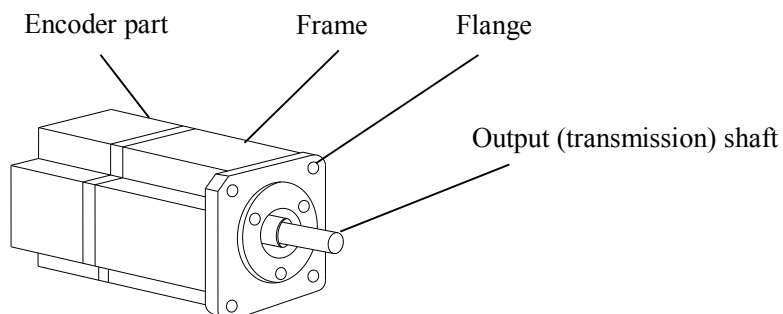

1-2-2. Servo Drivers

■ DS2-20P2, DS2-20P4, DS2-20P7

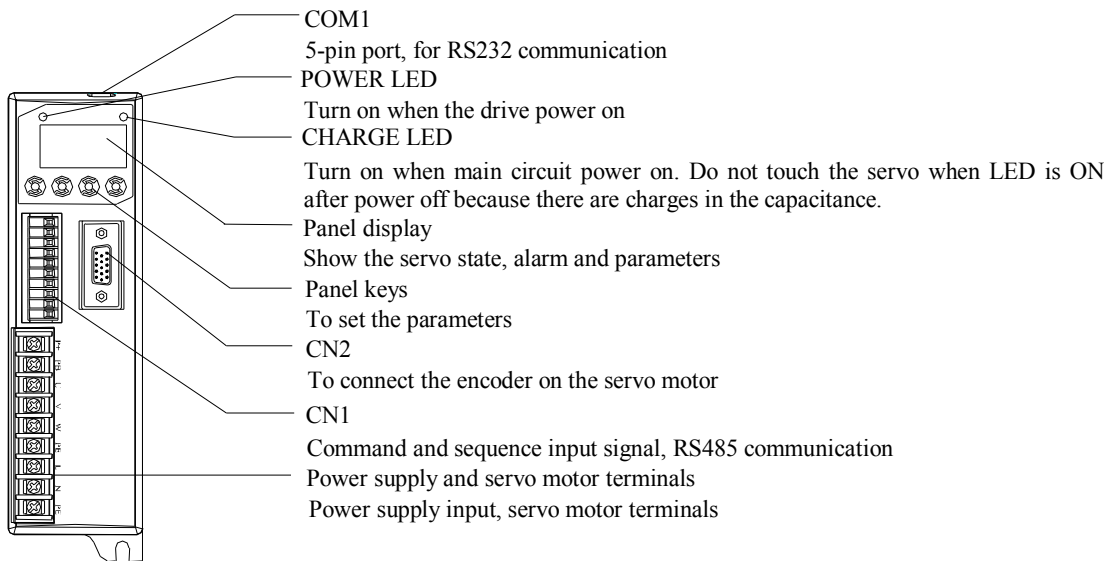

■ DS2-21P5

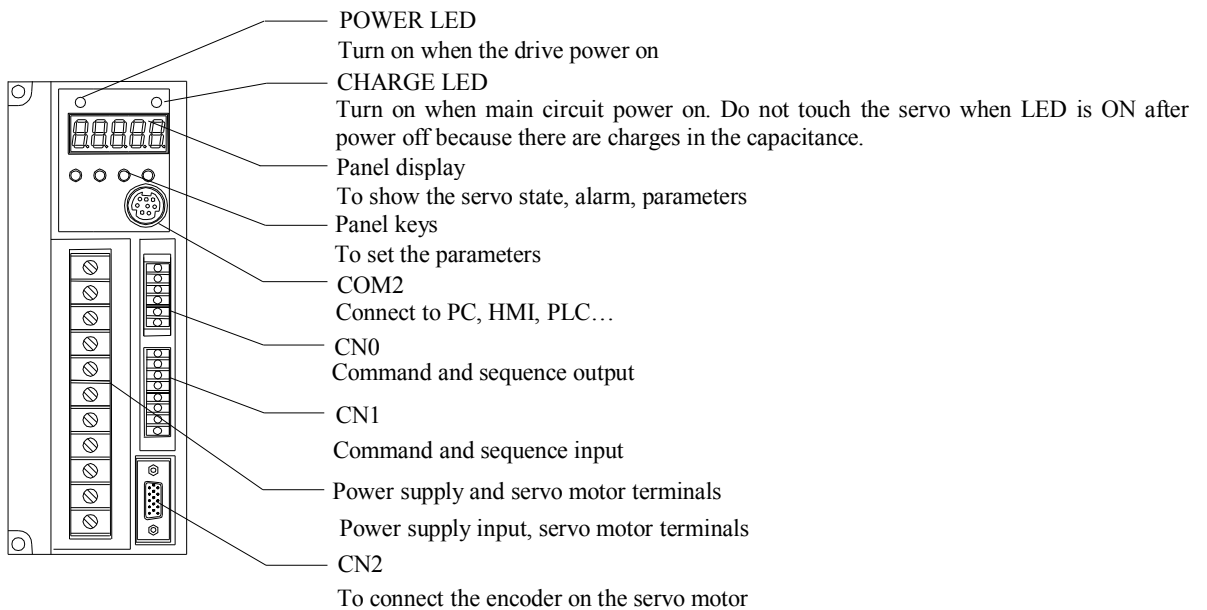

■ DS2-2□P□-A, DS2-2□P□-B

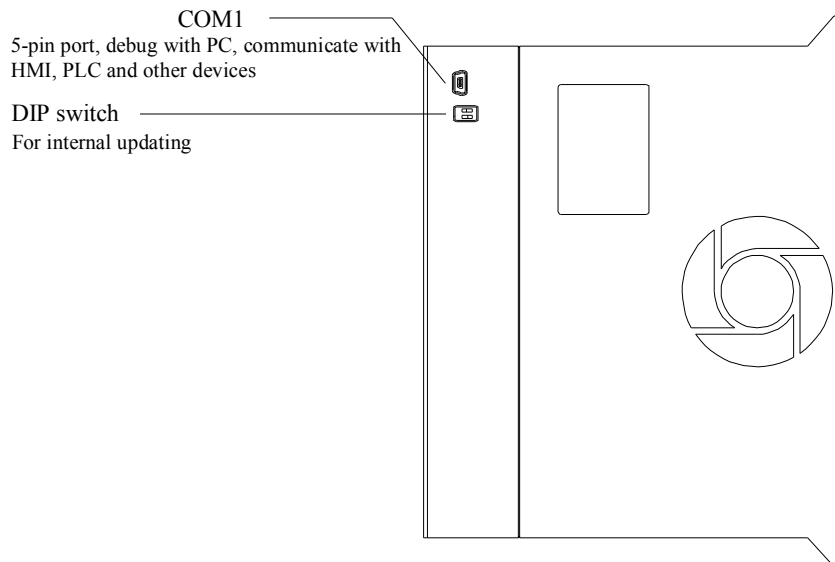
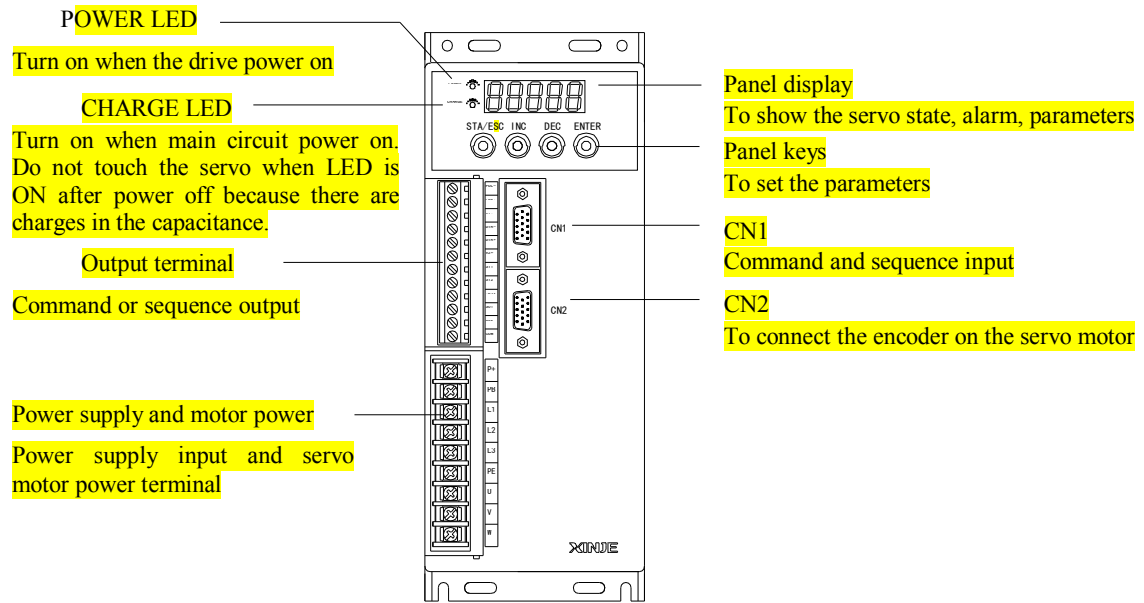

2 Installations

This chapter describes precautions for servomotor and servo driver installation.

2-1. Servomotor

MS series servomotors can be installed either horizontally or vertically. The service life of the servomotor can be shortened or unexpected problems might occur if it is installed incorrectly or in an inappropriate location. Follow these installation instructions carefully.



CAUTION

1. The end of the motor shaft is coated with antirust. Before installing, carefully remove all of the paint using a cloth moistened with paint thinner.
2. Avoid getting thinner on other parts of the servomotor.

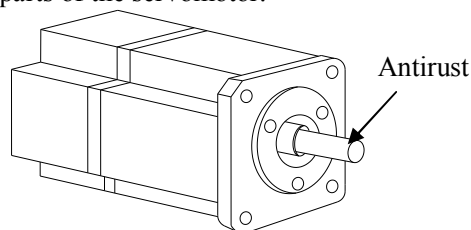

2-1-1. Storage Temperature

Store the servomotor within $-20\sim+60\text{ }^{\circ}\text{C}$ as long as it is stored with the power cable disconnected.

2-1-2. Installation Site

MS series servomotors are designed for indoor use. Install the servomotor in environments that satisfy the following conditions.

- Free of corrosive or explosive gases.
- Well-ventilated and free of dust and moisture.
- Ambient temperature of 0° to 50°C .
- Relative humidity (r.h.) of 20 to 80% with no condensation.
- Accessible for inspection and cleaning.

2-1-3. Concentricity

Please use coupling when connecting to machine; keep the shaft center of servo motor and machine at the same line. It should be accord to the following diagram when installing the servo motor.

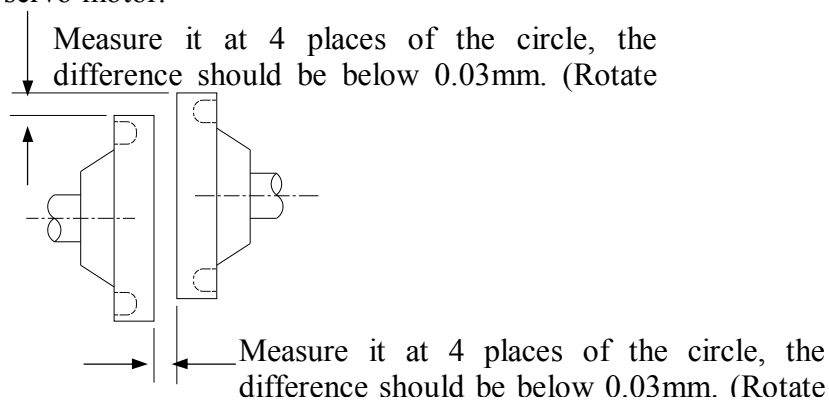

Note: (1) If the concentricity is not enough, it will cause the vibration and bearing

damage.

(2) When installing the coupler, prevent direct impact to the shaft. This can damage the encoder mounted on the shaft end at the opposite side of the load.

2-1-4. Orientation

MS series servomotors can be installed either horizontally or vertically.

2-1-5. Handling Oil and Water

Install a protective cover over the servomotor if it is used in a location that is subject to water or oil mist. Also use a servomotor with an oil seal when needed to seal the through-shaft section.

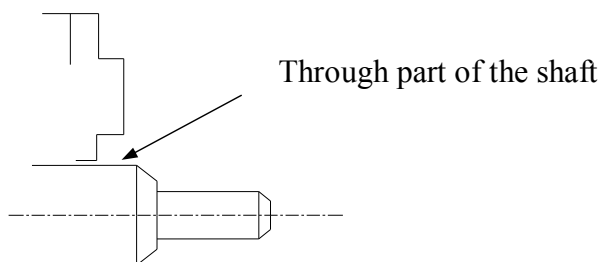

2-1-6. Cable Stress

Make sure that the power lines are free from bends and tension. Be especially careful to wire signal line cables so that they are not subject to stress because the core wires are very thin, measuring only 0.2 to 0.3mm².

2-2. Servo Drivers

The DS2 series servo drivers are base-mounted servo drivers. Incorrect installation will cause problems. Follow the installation instructions below

2-2-1. Storage Conditions

Store the servo driver within -20~+85°C, as long as it is stored with the power cable disconnected.

2-2-2. Installation Site

The following precautions apply to the installation site.

Situation	Installation Precaution
Installation in a Control Panel	Design the control panel size, unit layout, and cooling method so the temperature around the servo drivers does not exceed 50°C.
Installation Near a Heating Unit	Minimize heat radiated from the heating unit as well as any temperature rise caused by natural convection so the temperature around the servo drivers does not exceed 50°C.
Installation Near a Source of Vibration	Install a vibration isolator beneath the servo driver to avoid subjecting it to vibration.
Installation at a Site Exposed to Corrosive Gas	Corrosive gas does not have an immediate effect on the servo drivers, but will eventually cause electronic components and terminals to malfunction. Take appropriate action to avoid corrosive gas.
Other Situations	Do not install the servo driver in hot and humid locations or locations

subject to excessive dust or iron powder in the air.

2-2-3. Orientation

Install the servo driver perpendicular to the wall as shown in the figure. The servo driver must be oriented this way because it is designed to be cooled by natural convection or by a cooling fan.

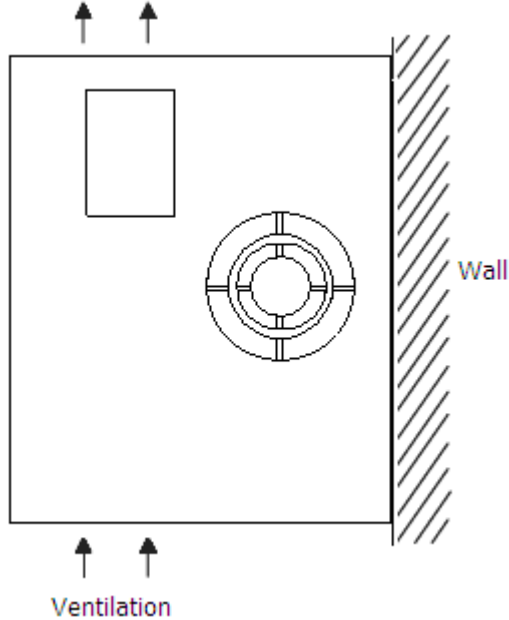

2-2-4. Installation

Follow the procedure below to install multiple servo drivers side by side in a control panel.

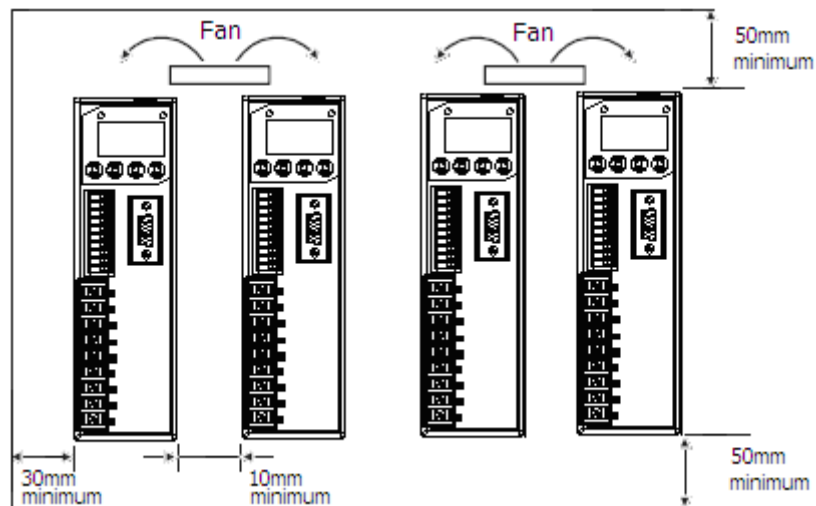

■ Servo Driver Orientation

Install the servo driver perpendicular to the wall so the front panel containing connectors faces outward.

■ Cooling

As shown in the figure above, allow sufficient space around each servo driver for cooling by cooling fans or natural convection.

■ Side-by-side Installation

When install servo drivers side by side as shown in the figure above, make at least 10mm between and at least 50mm above and below each servo driver. Install cooling fans above the servo drivers to avoid excessive temperature rise and to maintain even temperature inside the control panel.

■ **Environmental Conditions in the Control Panel**

- Ambient Temperature: 0~50 °C
- Humidity: 90%RH or less
- Vibration: 4.9m/s²
- Condensation and Freezing: None
- Ambient Temperature for Long-term Reliability: 50°C maximum

3 Wiring

This chapter describes the procedure used to connect DS2 Series products to peripheral devices and gives typical examples of main circuit wiring as well as I/O signal connections.

3-1. Main Circuit Wiring

This section shows typical examples of main circuit wiring for DS2 Series servo products, functions of main circuit terminals, and the power ON sequence.

Observe the following precautions when wiring.



Caution

1. Do not bundle or run power and signal lines together in the same duct. Keep power and signal lines separated by at least 11.81inch(30cm)
2. Use twisted pair wires or multi-core shielded-pair wires for signal and encoder (PG) feedback lines.
The maximum length is 118.11inch(3m) for reference input lines and is 787.40inch(20m) for encoder(PG) feedback lines.
3. Do not touch the power terminals for 5 minutes after turning power OFF because high voltage may still remain in the servo amplifier.
Please make sure to check the wiring after the CHARGE light is going off.
4. Avoid frequently turning power ON and OFF. Do not turn power ON or OFF more than once per minute.
Since the servo amplifier has a capacitor in the power supply, a high charging current flows for 0.2s when power is turned ON. Frequently turning power ON and OFF causes main power devices like capacitors and fuses to deteriorate, resulting in unexpected problems.

3-1-1. Names and Descriptions of Main Circuit Terminal

	■ DS2-20P2, DS2-20P4, DS2-20P7																		
	<table border="1"> <thead> <tr> <th>Terminal</th> <th>Function</th> <th>Explanation</th> </tr> </thead> <tbody> <tr> <td>P+, PB</td> <td>Regenerative braking resistor connection</td> <td>Connect regenerative braking resistor between P+ and PB</td> </tr> <tr> <td>U, V, W</td> <td>Motor connection</td> <td>Connect to the motor</td> </tr> <tr> <td>⊕</td> <td>Ground</td> <td>Connect to the ground terminal of motor, to be grounded</td> </tr> <tr> <td>L, N</td> <td>Power supply for main circuit</td> <td>Single-phase AC 200~240V, 50/60Hz</td> </tr> <tr> <td>⊕</td> <td>Ground</td> <td>Connect to the ground terminal of power, to be grounded</td> </tr> </tbody> </table>	Terminal	Function	Explanation	P+, PB	Regenerative braking resistor connection	Connect regenerative braking resistor between P+ and PB	U, V, W	Motor connection	Connect to the motor	⊕	Ground	Connect to the ground terminal of motor, to be grounded	L, N	Power supply for main circuit	Single-phase AC 200~240V, 50/60Hz	⊕	Ground	Connect to the ground terminal of power, to be grounded
	Terminal	Function	Explanation																
	P+, PB	Regenerative braking resistor connection	Connect regenerative braking resistor between P+ and PB																
	U, V, W	Motor connection	Connect to the motor																
	⊕	Ground	Connect to the ground terminal of motor, to be grounded																
	L, N	Power supply for main circuit	Single-phase AC 200~240V, 50/60Hz																
⊕	Ground	Connect to the ground terminal of power, to be grounded																	

Terminal	Function	Explanation
⊕1 ⊕2	Suppress current high harmonics, to connect DC reactor	⊕1 and ⊕2 is short when out of factory. Connect DC reactor between ⊕1 and ⊕2 to suppress current high harmonics.
L, N	Power input of main circuit	Single-phase AC 200~240V, 50/60Hz
⊕	Ground	Connect to the ground terminal of motor, to be grounded
U, V, W	Motor connection	Connect to the motor
⊕	Ground	Connect to the ground terminal of power, to be grounded
P+, PB	Regenerative braking resistor connection	Connect regenerative braking resistor between P+ and PB

Terminal	Function	Explanation
P+, PB	Regenerative braking resistor connection	Connect regenerative braking resistor between P+ and PB
L1, L2, L3	Power input of main circuit	3-phase AC 200~240V, 50/60Hz
⊕ (PE)	Ground	Connect to the ground terminal of power, to be grounded
U, V, W	Motor connection	Connect to the motor

3-1-2. Typical Wiring Example

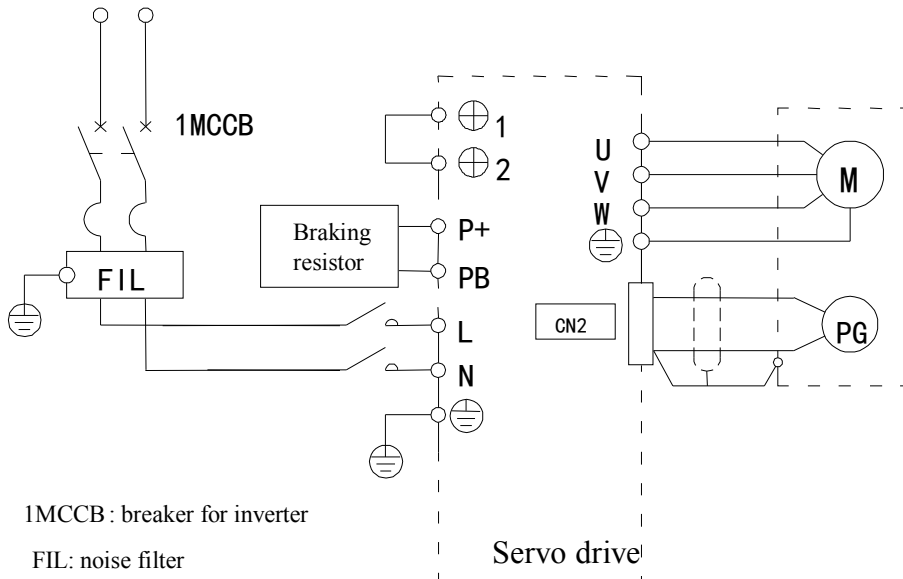

3-1-3. Winding Terminals on Servo motor

Symbol	60, 80, 90 Series	110, 130, 180 Series
PE	4	1
U	1	2
V	3	3
W	2	4

3-2. I/O Signals

This section describes I/O signals for the DS2 series servo driver.

3-2-1. Layout of CN0/CN1 Terminals

The diagram shows the solder side:

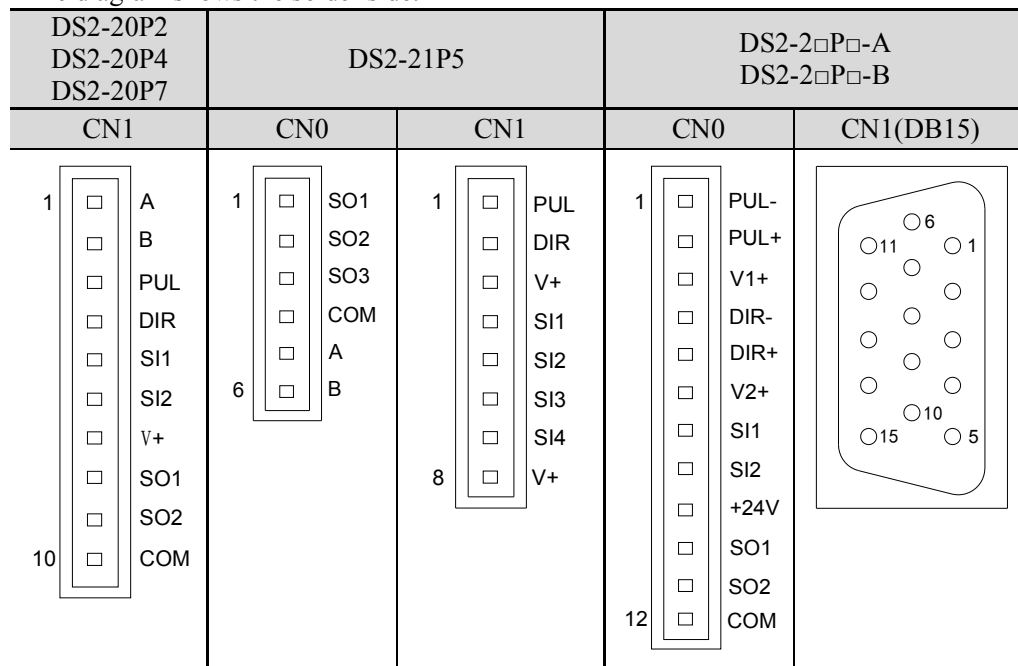

3-2-2. CN0 and CN1

DS2-20P2 DS2-20P4 DS2-20P7	■ CN1					
	No.	Name	Description	No.	Name	Description
	1	A	RS485+	6	SI2	Input terminal 2
	2	B	RS485-	7	+24V	+24V for input
	3	PUL	Pulse A, pulse signal	8	SO1	Output terminal 1
	4	DIR	Pulse B, direction signal	9	SO2	Output terminal 2
	5	SI1	Input terminal 1	10	COM	Ground of output
DS2-21P5	■ CN0					
	No.	Name	Description	No.	Name	Description
	1	SO1	Output terminal 1	4	COM	Ground of output
	2	SO2	Output terminal 2	5	A	RS485+
	3	SO3	Output terminal 3	6	B	RS485-
	■ CN1					
	No.	Name	Description	No.	Name	Description
	1	PUL	Pulse A, pulse signal	5	SI2	Input terminal 2

2	DIR	Pulse B, pulse signal	6	SI3	Input terminal 3
3	V+	+24V for pulse terminal	7	SI4	Input terminal 4
4	SI1	Input terminal 1	8	+24V	+24V for input

DS2-2□P□-A
DS2-2□P□-B

■ CN0

No.	Name	Description	No.	Name	Description
1	PUL-	Pulse input PUL-	7	SI1	Input terminal 1
2	PUL+	Differential input PUL+	8	SI2	Input terminal 2
3	V1+	+24V for open collector	9	+24V	+24V input
4	DIR-	Direction input DUL-	10	SO1	Output terminal 1
5	DIR+	Differential input DIR+	11	SO2	Output terminal 2
6	V2+	+24V for open collector	12	COM	Ground of output terminal

DS2-2□P□-A

■ CN1(DB15)

No.	Name	Description	No.	Name	Description
1	SI3	Input terminal 3	9	BO	Encoder output B
2	SI4	Input terminal 4	10	ZO	Encoder output Z
3	SI5	Input terminal 5	11	T-REF	Torque analog input
4	SI6	Input terminal 6	12	V-REF	Speed analog input
5	+24V	+24V input	13	GND	Ground for analog input
6	SO3	Output terminal 3	14	A	RS485+
7	COM	Ground for output terminal	15	B	RS485-
8	AO	Encoder output A			

DS2-2□P□-B

■ CN1 (DB15)

No.	Name	Description	No.	Name	Description
1	SI3	Input terminal 3	9	Z-	Encoder output Z-
2	SI4	Input terminal 4	10	B+	Encoder output B+
3	SI5	Input terminal 5	11	T-REF	Torque analog input
4	SO3	Output terminal 3	12	V-REF	Speed analog input
5	B-	Encoder output B-	13	GND	GND for analog input
6	A+	Encoder output A+	14	A	RS485+
7	A-	Encoder output A-	15	B	RS485-
8	Z+	Encoder output Z+			

3-2-3. I/O Signal Names and Functions

The following section describes servo driver I/O signal names and functions.

■ Input Signals

Item	Input	Function	Reference chapter
Digital input	SI1 ~ SI6	Multi-functional input terminal	5-12-1
Pulse input	PUL PUL- PUL+	P2-00=1: A-phase pulse P2-00=2: pulse	5-3-2
	DIR DIR- DIR+	P2-00=1: B-phase pulse P2-00=2: pulse direction (sign)	5-3-2

■ Output Signals

Class	Name	Functions	Reference chapter
Digital Output	SO1 ~ SO3	Multi-functions Output Terminals	5-12-2

Notes: the control signal must be grounded, please refer to chapter 3-4.

3-2-4. Interface Circuits

This section shows examples of servo driver I/O signal connection to the host controller.

■ The interface with the command input circuit

(1) Analog input circuit

<p>DS2-2□P□-A DS2-2□P□-B</p>	<p>Host device servo drive</p>
<p>The analog signal is speed command or torque command. The input impedance is shown as below.</p> <ul style="list-style-type: none"> • speed command input: about 13KΩ • torque command input: about 13KΩ • max allowed voltage of input signal: ±10V 	

(2) Position command input circuit

DS2-20P2
 DS2-20P4
 DS2-20P7
 DS2-21P5

- Open collector output (power supply is 24V)

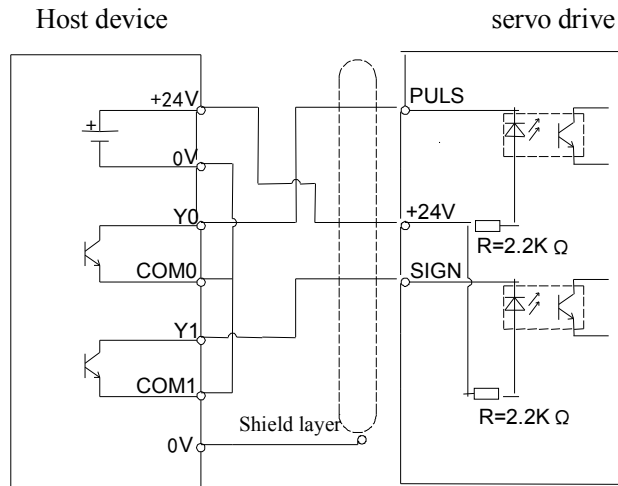

DS2-2□P□-A
 DS2-2□P□-B

- Open collector output (power supply is 24V)

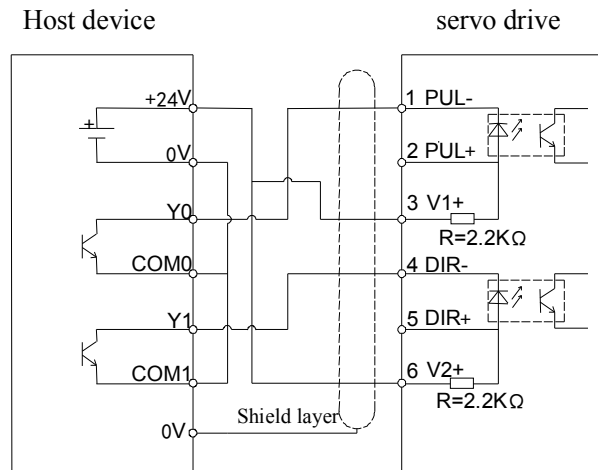

When the host device is open collector output, PUL+(2) and DIR+(5) must be vacant.

- Differential output (power supply is 5V)

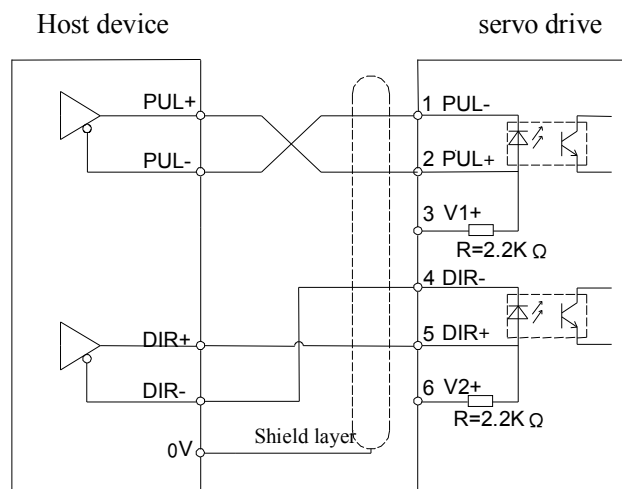

When the host device is 5V differential signal output, V1+(3) and V2+(6) must be vacant.

■ The interface with the input circuit

Use relay or open collector transistor circuit to connect. Please choose micro-current relay when using relay. Otherwise, the contact will be not good.

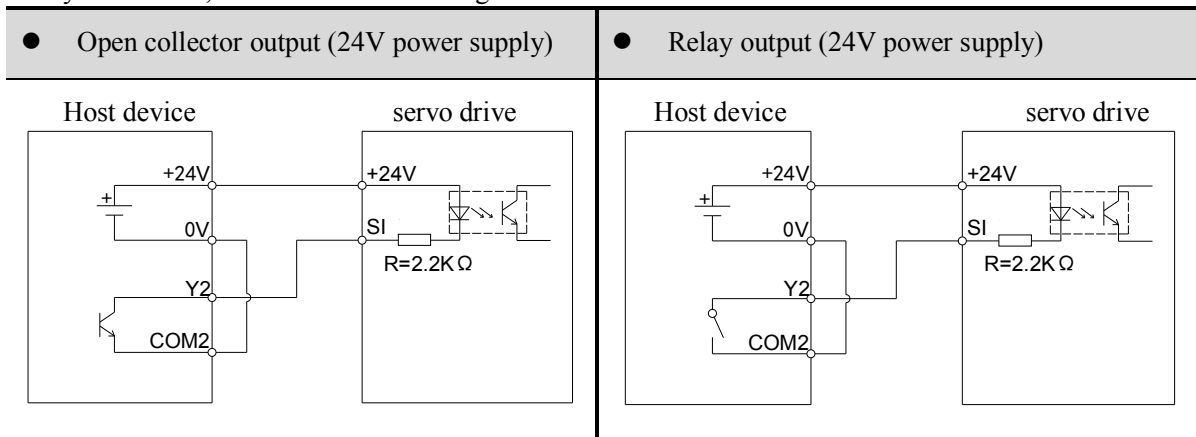

Notes: the max allowable voltage and current of open collector output:

Voltage: DC30V (max)

Current: DC50mA (max)

■ The interface with the output circuit

The signal output circuit of servo unit is open collector signal. Please build the input circuit at the host side according to the output circuit condition.

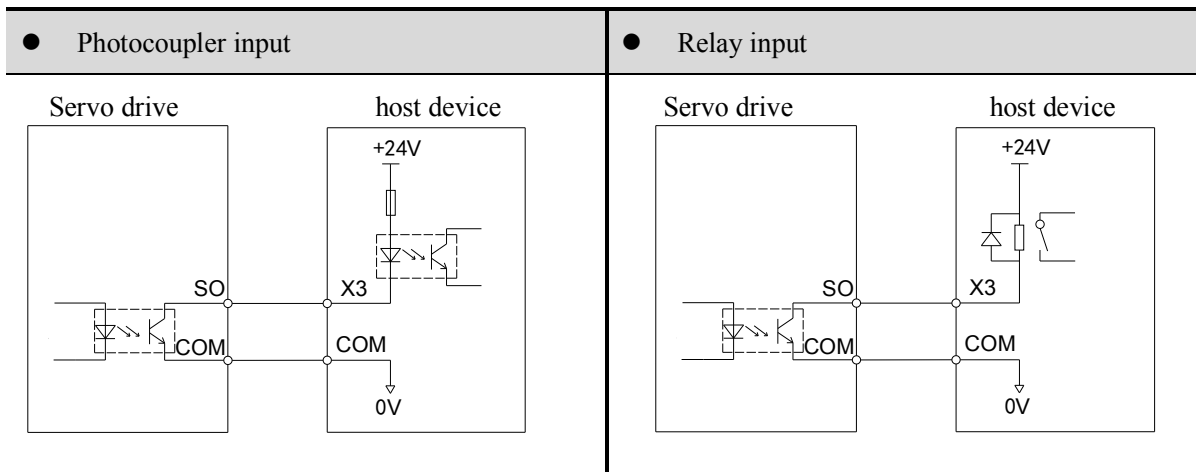

3-3. Wiring Encoders

The following sections describe the procedure for wiring a servo driver to the encoder.

3-3-1. Encoder Connections

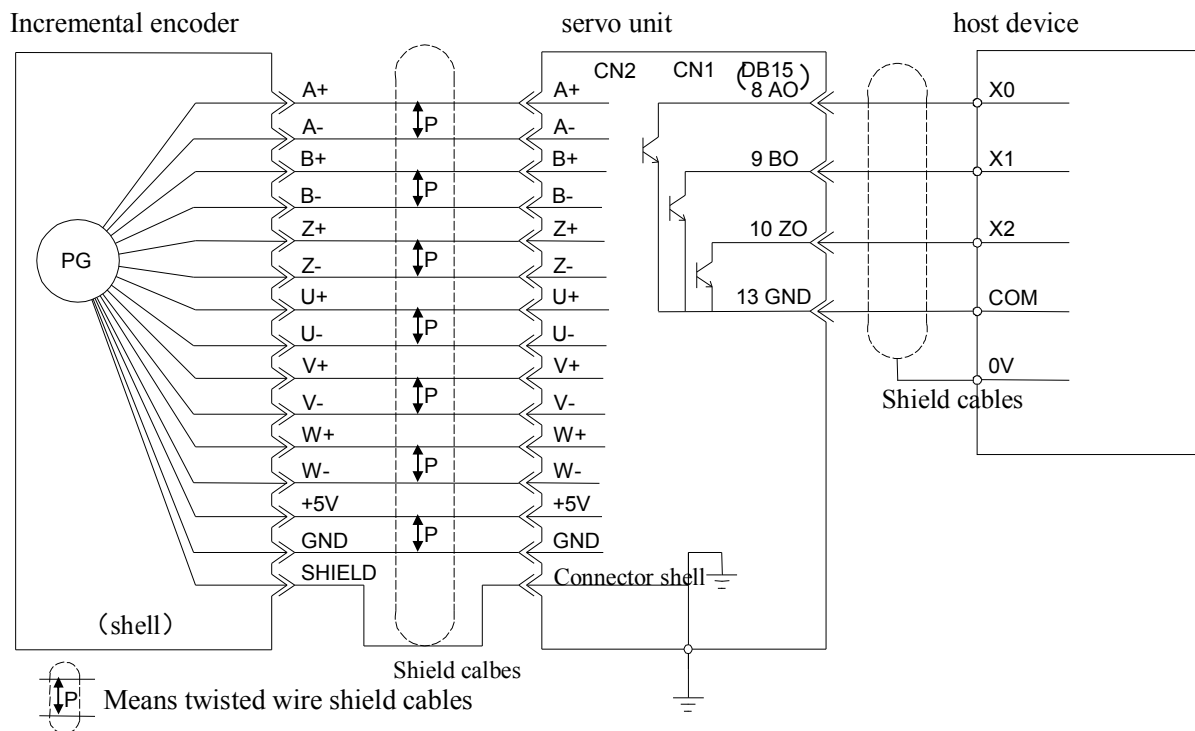

3-3-2. CN2 Encoder Connector Terminal Layout

■ CN2 Connector Terminal Layout

The following diagrams are the layout of CN2 connector (face the solder pin).

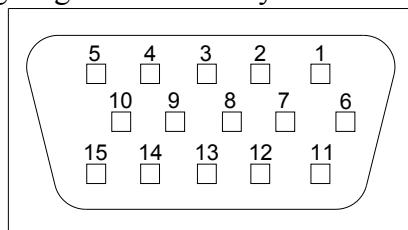

■ CN2 Connector Terminal Description

Driver Side	Encoder Side On Motor		Name	Driver Side	Encoder Side On Motor		Name
	60, 80, 90 series	110, 130, 180 series			60, 80, 90 series	110, 130, 180 series	
1	9	4	A+	2	4	5	B+
3	7	6	Z+	4	6	10	U+
5	11	12	W+	6	13	7	A-
7	14	8	B-	8	5	9	Z-
9	8	13	U-	10	15	15	W-
11	1	1	Shield	12	3	3	GND
13	2	2	5V	14	10	11	V+
15	12	14	V-				

3-4. Standard connection examples

This chapter explains the standard connection examples as the spec and control type. The I/O signals used on input and output terminals are assigned by default. This assignment could be changed in various conditions. Please refer to 5-12.

Besides, the control signal wires must connect to the ground, the ground method is shown as below:

The shield method of control signal wires:

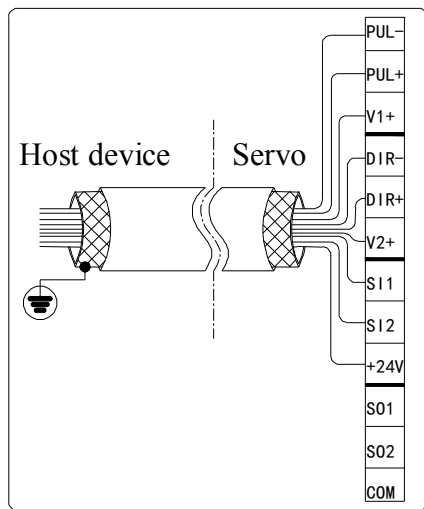

*single-ground the shield layer

3-4-1. Position Control Mode

■ DS2-20P2, DS2-20P4 and DS2-20P7

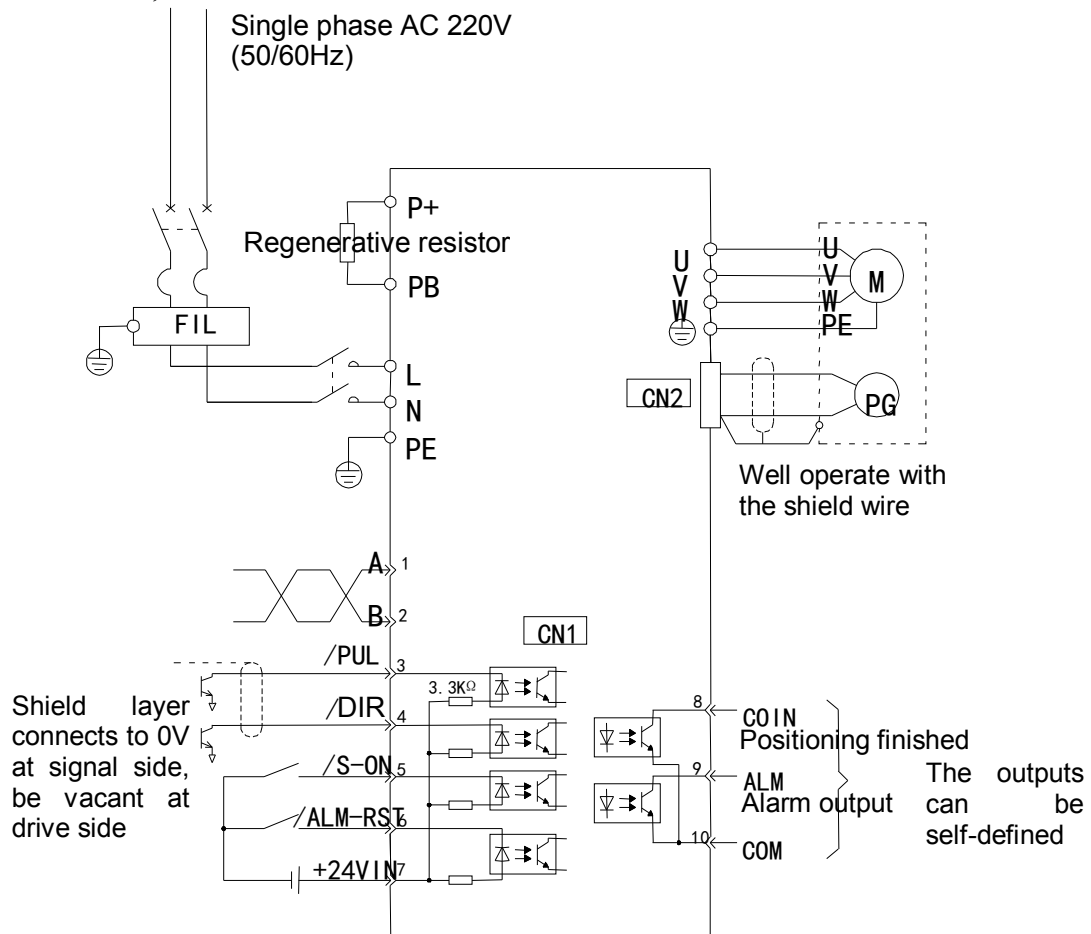

■ DS2-21P5

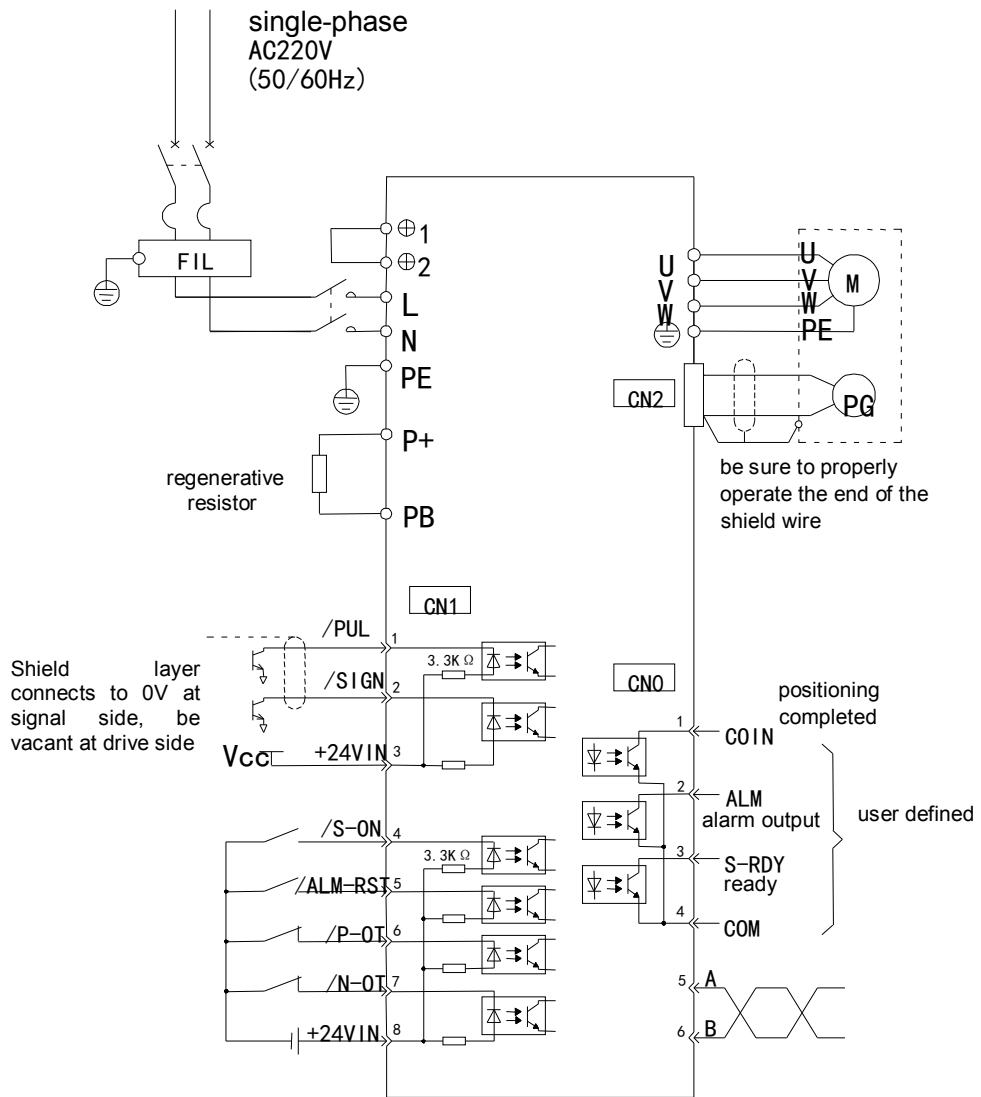

■ DS2-2□P□-A, DS2-2□P□-B

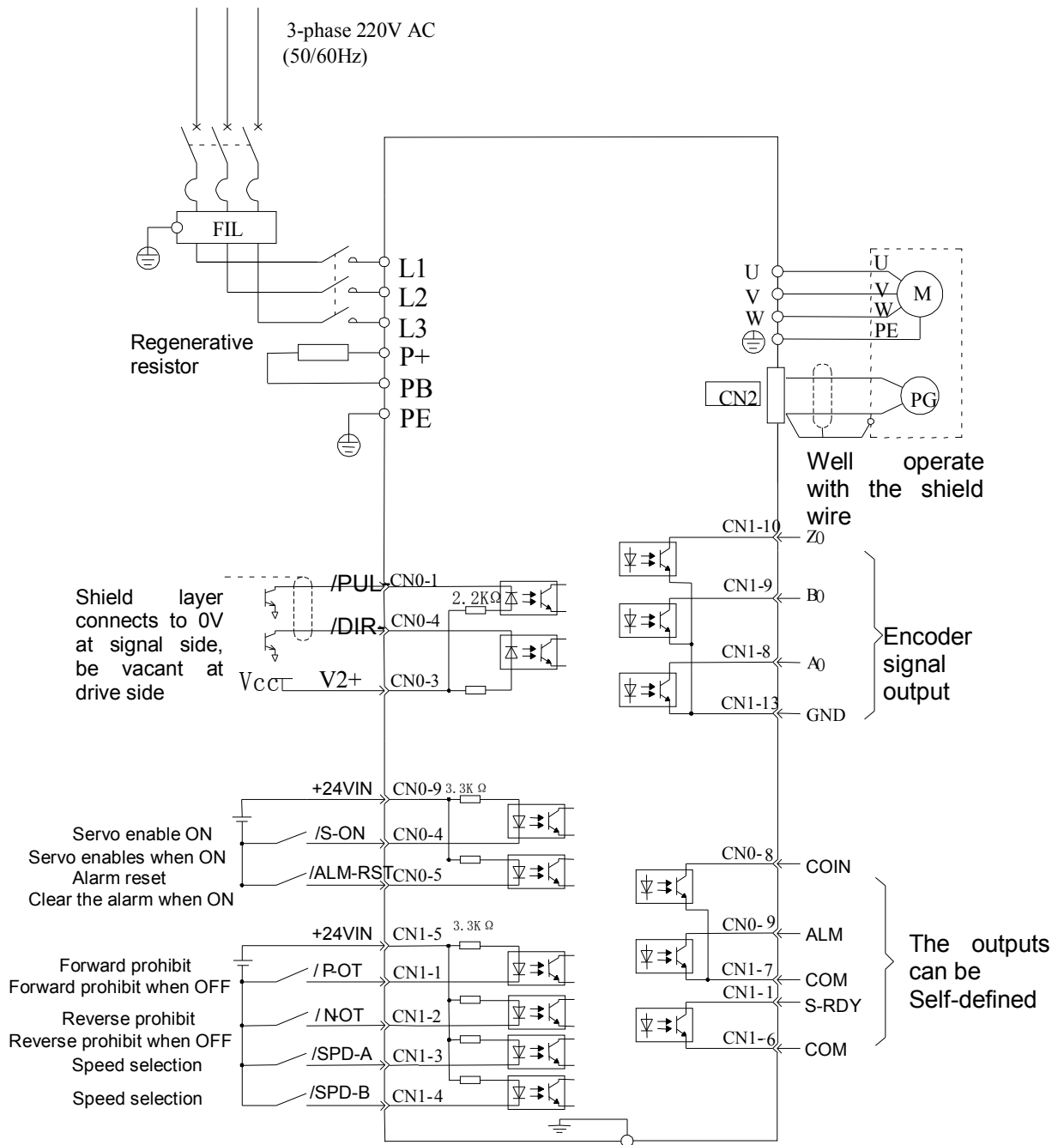

3-5. Communication Port

3-5-1. Serial Port 1(COM1)

COM1 supports RS232, and is often used to connect with PC for debugging.

DS2-20P2, DS2-20P4, DS2-20P7, DS2-2□P□-A, DS2-2□P□-B

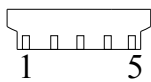

(5-pin port)

Pin	Name	Explanation
1	TXD	RS232 send
2	RXD	RS232 receive
3	GND	RS232 ground

Note: 1, Please use the cable provided by Xinje company.
 2, the types in the table cannot use RS232 (COM1) and RS485 (COM2) at the same time.
 The communication parameters of COM1 and COM2 will be changed at the same time.

■ DS2-21P5

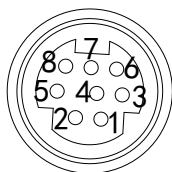

8-pin DB port

Number	Name	Description
2	UPGRADE	Self Upgrade
4	RXD	RS232 receive
5	TXD	RS232 send
8	GND	RS232 ground

3-5-2. Serial Port 2(COM2)

Communication parameters of COM2 can be set via P0-04. It supports Modbus-RTU communication.

Parameter Number	Name	Default Setting	Range
P0-04.0	Baud rate	6	0: 300 1: 600 2: 1200 3: 2400 4: 4800 5: 9600 6: 19200 7: 38400 8: 57600 9: 115200
P0-04.1	Data Bits	0	0: 8 bits
P0-04.2	Stop Bits	2	0: 2 bits. 2: 1 bit
P0-04.3	Parity	2	0: No Parity. 1: Odd Parity. 2: Even Parity

Modbus station number can be set freely, depending on the following parameter.

Parameter Number	Name	Unit	Default Setting	Range
P0-03	Modbus Station Number	-	1	1~255

Note: Parameters above will take effect after repower on.

COM2 of all the types:

Type	COM2	Standard	Remark
DS2-20P2 DS2-20P4 DS2-20P7	A (CN1-1) B (CN1-2)	RS485	The communication port on CN1 cannot be used with 5-pin ladder port at the same time.
DS2-21P5	A (CN0-5) B (CN0-6)	RS485	
DS2-2□P□-A DS2-2□P□-B	A (CN1-14) B (CN1-15)	RS485	The communication port on CN1 cannot be used with 5-pin ladder port at the same time.

3-6. Regenerative Resistor

When the servo motor operates in generator mode, power is returned to the servo driver side. This is called regenerative power. The regenerative power is absorbed by charging the smoothing capacitor, but when the capacitor's charging limit is exceeded, the

regenerative power needs to be reduced by the regenerative resistor.

The servomotor is driven in regeneration (generator) mode in the following conditions:

- While decelerating to a stop during acceleration/deceleration operation.
- With a load on the vertical axis.
- During continuous operation with the servomotor driven from the load side (negative load).

Connecting Regenerative Resistors

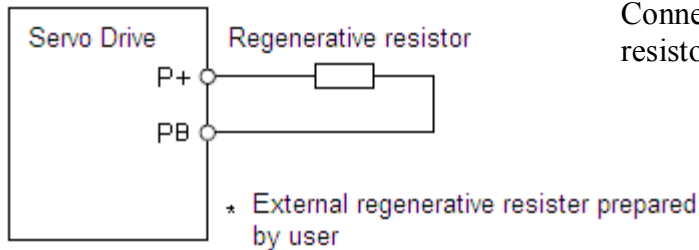

Connect an external regenerative resistor between P+ and PB.

Note: Adequate cooling must be provided for regenerative resistors because they reach very high temperatures. Also use heat-resistant, non-flammable wire and make sure that the wiring does not come into contact with the resistors.

Motor model	Suggested resistor	Suggested power	Min resistor
MS-60ST-M00630□□-20P2	50Ω	100W	50Ω
MS-60ST-M01330□□-20P4	50Ω	100W	40Ω
MS-80ST-M02430□□-20P7	50Ω	100W	40Ω
MS-90ST-M02430□□-20P7	50Ω	100W	40Ω
MS-110ST-M04030□□-21P2	50Ω	100W	40Ω
MS-110ST-M05030□□-21P5	50Ω	100W	40Ω
MS-130ST-M06025□□-21P5	50Ω	200W	40Ω
MS-130ST-M07725□□-22P0	50Ω	200W	40Ω
MS-130ST-M10015□□-21P5	50Ω	200W	40Ω
MS-130ST-M15015□□-22P3	50Ω	300W	40Ω
MS-180ST-M19015□□-23P0	50Ω	300W	40Ω

Note: The *Recommended Power* means that the value may be suitable to most applications. Nevertheless, in real conditions, actual power could be more or less than the recommended value, so the rated power should be flexible to actual temperature of the regenerative resistor.

4 Use the operate panel

This chapter describes the basic operation of the operate panel and the features it offers. All parameter settings and motor operations can be executed by simple, convenient operations.

4-1. Basic Operation

This section provides information on the basic operation of the operate panel for setting operating conditions.

4-1-1. Functions of operate panel

The operate panel can be used for parameter settings, operating references, and status displays.

- 5-bit LED: Displaying parameter settings, status or alarm.
- Power LED POWER: The LED is on when the servo driver is powered on.
- Charge LED CHARGE: The LED is on when the main circuit is powered on. When the power of main circuit is off, electric charges remain in the capacitors, and at this time DO NOT touch the servo.

This section provides information on the keys and their functions available from the initial displays.

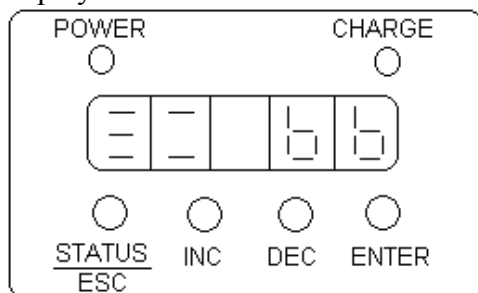

Key Name	Function
STATUS/ESC	Press: Status switch, status return
INC	Press: Increase the value; Press and hold: Increase the value continuously
DEC	Press: Decrease the value; Press and hold: Decrease the value continuously
ENTER	Press: Shift the editing digit; Press and hold: Enter a status, Enter

4-1-2. Basic Mode Switching

The operate panel can display the status, set parameter and run the command by switching the basic mode.

The running status, auxiliary function, parameter setting, and monitoring are the basic modes. The modes switch as the below diagram by pressing STATUS/ESC.

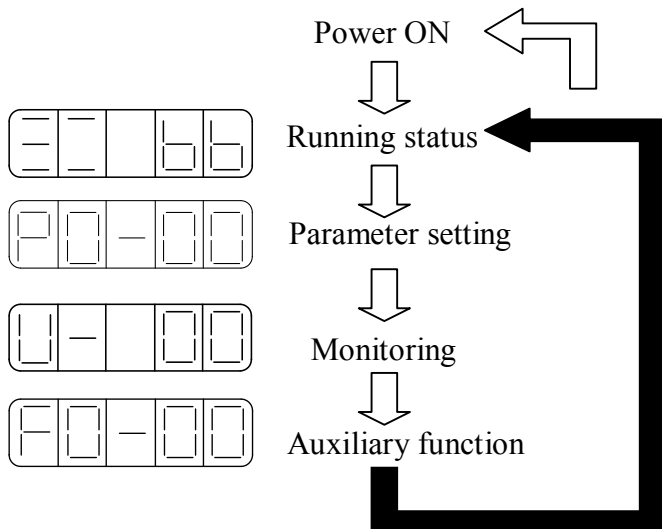

Display mode:

- Monitor Function U— XX: XX means the number of the monitor function.
- Auxiliary Function FX—XX: The first X means group No., the last two X means the member No. in the group.
- Parameter Setting PX—XX: The first X means group No., the last two X means the member No. in the group.
- Alarm E—XXX: XXX means the alarm code.

4-2. Running status mode

In running status mode, bit data and codes indicate the status of the servo driver.

■ Select the running status mode

The servo will enter running status when power on. If not, press STATUS/ESC to enter.

■ The display content of running status mode

The display contents are different in speed, torque, position control mode.

➤ Speed and Torque Control Mode

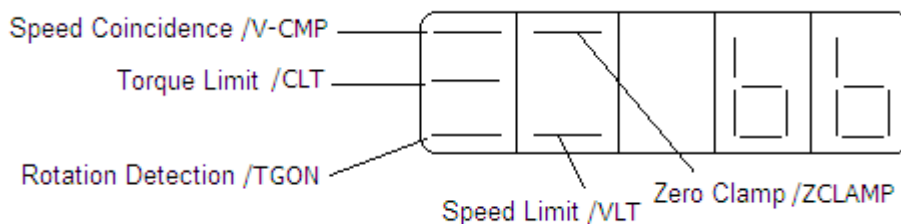

A. Bit contents:

Bit Data	Description
Speed Coincidence (/V-CMP)	Light when the motor actual speed and command speed is the same. Speed coincidence signal checking width: P5-03 (unit: rpm)
Torque Limit (/CLT)	Light when actual torque exceeds preset value. Forward Torque Limit: P4-02 Reverse Torque Limit: P4-03
Rotation Detection	Light when the motor speed exceeds the rotation detection speed.

(/TGON)	Rotation Detection Speed Level: P5-02(Unit: rpm)
Zero Clamp (/ZCLAMP)	Light when zero clamp signal is ON.
Speed Limit (/VLT)	Light when actual speed exceeds preset value. Speed Limit during Torque Control: P4-07

B. The code contents:

Code	Description
	Standby Servo OFF (motor power OFF)
	Run Servo ON (motor power ON)
	Forward Run Prohibited P-OT is OFF. Please refer to 5-2-3 “Overtravel Limit”
	Reverse Run Prohibited N-OT is OFF. Please refer to 5-2-3 “Overtravel Limit”

➤ Position Control Mode

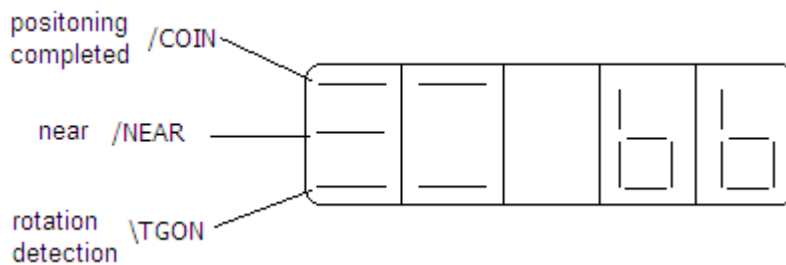

A. The bit contents:

Bit Data	Description
Positioning Completed (/COIN)	Light when set position and actual position is the same. Positioning accomplishment width: P5-00 (unit: command pulse)
Near (/NEAR)	Light when set position and actual position is the same. Near signal width: P5-04
Rotation Detection (/TGON)	Light when the motor speed exceeds the rotation detection speed. Rotation detection speed: P5-02(unit: rpm)

B. The code contents:

Code	Description
	Standby Servo OFF (motor power OFF)
	Run Servo ON (motor power ON)
	Forward Run Prohibited P-OT is OFF. Please refer to 5-2-3 “Overtravel Limit”
	Reverse Run Prohibited N-OT is OFF. Please refer to 5-2-3 “Overtravel Limit”

4-3. Monitoring Mode

The Monitoring Mode can be used to monitor the reference values, I/O signal status, and servo driver internal status.

The monitor mode can be set when the motor is running.

■ Using the Monitor Mode

Now we take the monitor code U-16 as an example.

1. Press the STATUS/ESC key to select the monitoring mode.

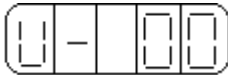

2. Press the INC or DEC key to select the monitor number U-16, and then press and hold ENTER to enter the monitor mode.



3. The value 0 is now displayed.



4. Press STATUS/ESC key to return to the monitoring number switching state.

■ Display contents of Monitoring Mode

Number	Monitor Display	Unit
U-00	Actual speed of motor	Rpm
U-01	Input speed command	Rpm
U-02	Internal torque command	%
U-03	Rotate angle (mechenism angle)	0.1°
U-04	Rotate angle (electrical angle)	0.1°
U-05	Bus voltage	V
U-06	Module temperature	0.1℃
U-07	Input command pulse speed	Rpm
U-08	Pulse value of shift command	(0000~9999)*1
U-09		(0000~9999)*10000
U-10	Rotate angle (encoder value)	(0000~9999)*1
U-11		(0000~9999)*10000
U-12	Pulse value of input command	(0000~9999)*1
U-13		(0000~9999)*10000
U-14	Pulse value of feedback command	(0000~9999)*1
U-15		(0000~9999)*10000
U-16	Current position (Accumulated)	(0000~9999)*1
U-17		(0000~9999)*10000
U-18	Current, 1-bit decimal	0.1A
U-19	Analog input V-REF	0.01V
U-20	Analog input T-REF	0.01V
U-21	I/O signals status	
U-22	I/O terminals status	

■ U-21 displays I/O signals status

The following diagram describes the input and output signals status displayed in U-21.

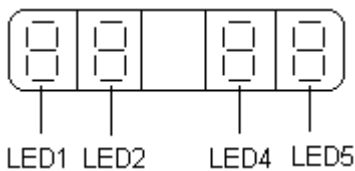

Diagram 1

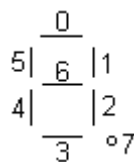

Diagram 2

In diagram 1, LED4 and LED5 stand for input signals status, and LED1 and LED2 stand for output signals status. In diagram 2 there shows the segment No. of each LED.

➤ Input signals status

Segment	Description	Segment	Description
LED4_0	/SPD-A internal set speed selection	LED5_0	/S-ON servo signal

LED4_1	/SPD-B internal set speed selection	LED5_1	/P-CON proportion action command
LED4_2	/C-SEL control mode selection	LED5_2	/P-OT forward prohibit
LED4_3	/ZCLAMP zero clamp	LED5_3	/N-OT reverse prohibit
LED4_4	/INHIBIT prohibit pulse command	LED5_4	/ALM-RST clear the alarm
LED4_5	/G-SEL switch the gain	LED5_5	/P-CL external torque limit at forward side
LED4_6	/CLR clear the pulse	LED5_6	/N-CL external torque limit at reverse side
LED4_7	/CHGSTP change the step	LED5_7	/SPD-D internal set speed selection

➤ Output signals status

Segment	Description	Segment	Description
LED1_0	/NEAR near	LED2_0	/COIN positioning completed
LED1_1	/ALM alarm output	LED2_1	/V-CMP speed synchronization checking
LED1_2	/Z encoder Z phase output	LED2_2	/TGON rotate checking
		LED2_3	/S-RDY ready
		LED2_4	/CLT torque limit
		LED2_5	/VLT speed limit checking
		LED2_6	/BK brake lock
		LED2_7	/WARN warn

■ U-22 displays I/O terminals status

The following diagram describes the input and output terminals status:

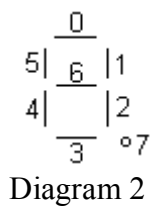
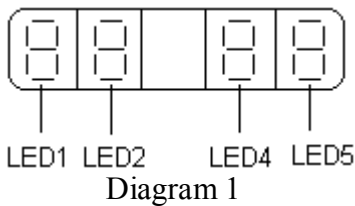

In diagram 1, LED5 stands for input signals status, and LED2 stands for output signals status. In diagram 2 there shows the segment No. of each LED.

Input terminals		Output terminals	
Segment	Description	Segment	Description
LED5_0	Input status of SI1	LED2_0	Output status of SO1
LED5_1	Input status of SI2	LED2_1	Output status of SO2
LED5_2	Input status of SI3	LED2_2	Output status of SO3
LED5_3	Input status of SI4		
LED5_4	Input status of SI5		
LED5_5	Input status of SI6		

4-4. Auxiliary Function

Use the operate panel to do application in auxiliary function mode.

Group No.	Content
F0-**	Check system information, display the system code and data
F1-**	Auxiliary run mode, display the auxiliary run command and result
F2-**	Set the motor code
F3-**	Check the alarm information, clear the alarm
F4-00	Reset parameters to default
F5-00	External communication monitoring

4-4-1. Check System Information

Press STATUS/ESC to switch to the auxiliary function mode. Set the group No. to 0 to check system information. Press INC or DEC key to select different No., and press and hold ENTER key to check current information. Press STATUS/ESC key to return.

The following table describes the meaning of each No.

Function No.	Description	Function No.	Description
F0-00	Motor Code	F0-01	Servo Series
F0-02	Servo Model	F0-03	Produce Date: Year
F0-04	Produce Date: Month	F0-05	Produce Date: Day
F0-06	Software Version	F0-07	Hardware Version

4-4-2. Auxiliary Run Mode

Press the STATUS/ESC key to select the auxiliary function mode. Set the group No. to 1. Press INC or DEC key to select different No., and press and hold ENTER key to use current function. Press STATUS/ESC key to return.

1. Jog (F1-00)

Make sure that the motor shaft is not connected to the machine before jogging!

Press ENTER to power on the motor (servo on). Press INC for forward jogging, press DEC for reverse jogging. Press STATUS/ESC key to power off the motor (servo off), and press STATUS/ESC key again to return.

4 different states of jogging:

State	Panel Display	State	Panel Display
Idle		Forward Jogging	
Servo ON		Reverse Jogging	

Set the related parameters:

P3-04	JOG speed					
	Unit	Default	Setting range	Suitable mode	Change	Effective
	Rpm	100	0~500	JOG	Servo OFF	Immediately

2. Trial Operation (F1-01)

Make sure that the motor shaft is not connected to the machine before trial operation!

When servo driver is connected with non-original encoder line or power line, trial operation must be run first to ensure that the encoder line or power line is connected correctly.

Set the display value to 1, and press and hold ENTER key to enter trial operation mode. The operate panel displays:



If correctly wired, the motor would rotate in 5 seconds in forward direction (fixed to counter-clockwise), otherwise the motor would shock or vibrate, raising an alarm for worse. In this case the power must be switched off immediately and check the wiring again.

Press STATUS/ESC key to return.

3. Current Offset Auto-Adjustment (F1-02)

After the servo driver is updated to latest software version, or the motor does not revolve smoothly for long time, the current offset auto-adjustment is recommended.

Select F1-02 and enter current offset auto-adjustment function, and the panel displays “rEF”.

Press ENTER key to start current offset auto-adjustment, and the panel displays blinking “rEF”.

About 5 seconds later auto-adjustment is finished, and the panel displays “donE” to inform that the function is already finished.

Press STATUS/ESC key to return.

4. Speed command offset auto-adjustment (F1-03)

Select F1-03 and enter speed command offset auto-adjustment function, and the panel displays “rEF_o”.

Press ENTER key to start speed command offset auto-adjustment, and the panel displays blinking “rEF_o”.

About 1 second later, auto-adjustment is finished, and the panel displays “donE” to inform that the function is already finished.

Press STATUS/ESC key to return.

5. Torque command offset Auto-Adjustment (F1-04)

Select F1-04 and enter torque command offset auto-adjustment function, and the panel displays “rEF_o”.

Press ENTER key to start torque command offset auto-adjustment, and the panel displays blinking “rEF_o”.

About 1 second later, auto-adjustment is finished, and the panel displays “donE” to inform that the function is already finished.

Press STATUS/ESC key to return.

6. Forced Servo enables (F1-05)

0: Cancel forced servo enables

1: Forced servo enables

4-4-3. Change the motor type

Set the group No. to 2 in auxiliary function mode.

The servo drive can match multi-servo-motor with close power classes printed on the nameplate of each motor. When user needs to change a motor, please refer to the Quick Guide to ensure the motor match the driver.

The following steps are how to change motor type.

1. Press STATUS/ESC key to select Auxiliary Function mode.
2. Press INC or DEC key to set group No. to 2, and press ENTER to confirm.
3. Press and hold ENTER key to display current motor type.
4. Press INC, DEC or ENTER key to show the motor type and press and hold ENTER key to confirm.

5. Repower on the servo drive to make this function effective.

4-4-4. Check Alarm Information

Set group No. to 2 in auxiliary function mode and enter checking alarm information mode. The following steps show how to check alarm information.

1. Press STATUS/ESC key to select Auxiliary Function mode.
2. Press INC or DEC key to set group No. to 3, and press ENTER key.
3. Press INC, DEC or ENTER key to modify the alarm No.
4. Press and hold ENTER key to display corresponding alarm information.

Member No.	Description	Unit
F3-00	Current alarm code ※1	
F3-01	Current warn code ※2	
F3-02	Alarm/warn code 1 when alarm	
F3-03	U phase current when alarm	A
F3-04	V phase current when alarm	A
F3-05	DC bus-voltage when alarm	V
F3-06	IGBT module temperature when alarm	°C
F3-07	Speed when alarm	rpm
F3-08	Internal torque command when alarm	%
F3-09	V-REF value when alarm	V
F3-10	T-REF value when alarm	V
F3-11	Alarm/warn code 2 when alarm	
F3-12	Alarm/warn code 3 when alarm	
F3-13	Alarm/warn code 4 when alarm	
F3-14	Alarm/warn code 5 when alarm	
F3-15	Alarm/warn code 6 when alarm	
F3-16	Alarm/warn code 7 when alarm	

※1: F3-00=0 indicates that there is no alarm.

※2: F3-01=0 indicates that there is no warn.

4-4-5. Reset Parameters to Default

The following steps show how to reset parameters to default.

1. Press STATUS/ESC key to select Auxiliary Function.
2. Press INC or DEC key to set group No. to 4, and press ENTER key.
3. Press and hold ENTER key, and the panel displays “0” and is blinking.
4. Set the value to 1. Press and hold ENTER key to confirm.
5. Repower on the drive and the parameters are all reset to default.

4-4-6. External monitoring

Select F5-00 in auxiliary function, the panel displays “C-OUT” which means external monitoring mode, COM1 is effective, operate panel is ineffective. At this time user can debug the servo via PC.

Press STATUS/ESC to return.

4-5. Parameter Setting

Select or adjust the functions via parameter setting. Please refer to appendix 1 for parameters list.

The following steps show how to change a parameter.

Check the permitted range of the parameters in appendix 1.

The example below shows how to change parameter P3-09 from 2000 to 3000.

1. Press the STATUS/ESC key to select the parameter setting mode.

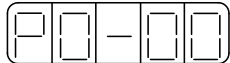

2. At this time the second LED is blinking, and press INC or DEC key to set the group No. to 3. Press ENTER key to confirm.

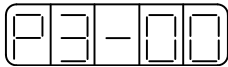

3. At this time the last LED is blinking, and press INC or DEC key to set the member No. to 9. Press and hold ENTER key to confirm.

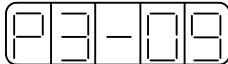

4. At this time the panel displays the value in P3-09, and the last decimal "0" is blinking. Press ENTER to left shift the blinking decimal. Press INC, DEC or ENTER key to modify the value to 3000, and press and hold ENTER to confirm.



The parameter in P3-09 is changed from 2000 to 3000.

Repeat steps 2 to 4 to change the parameter again.

5. Press STATUS/ESC key to return.

4-6. Alarm

Alarm code will pop up (E-XXX) if there is error in servo. The alarm state is invisible when there is no error in servo. Press ENTER to reset the alarm.

It is no need to reset the alarm when the servo is OFF because of error.

Notes: when there is alarm, please clear the alarm reasons, then reset the alarm.

5 Run the servo system

This chapter describes the basic function and using method of DS2 series servo.

5-1. Control mode selection

DS2 series servo has one main mode and two sub modes. Sub mode 1 and 2 can be switched to each other via /C-SEL signal.

Parameter		Control mode	Reference
P0-00	0	Testing mode, users cannot change!	
P0-01 Sub mode1	0	Idle mode The motor will not power on even if the servo drive enables.	
	1	Torque control (internal setting) Control the output torque of servo motor via operating panel or communication.	5-9
	2	Torque control (analog voltage command) Control the output torque of servo motor via analog voltage command. It is mostly used to close-loop torque control with upper device, such as tension control. (If servo drive doesn't have analog input port, it cannot use this mode.)	5-8
	3	Speed control (internal speed setting) Use /SPD-D, /SPD-A, /SPD-B to select the speed which is set in the servo drive. The servo drive can set 3 speeds.	5-6
	4	Speed control (analog voltage command) Control the speed of servo motor via analog voltage command. It is mostly used to close-loop speed control with upper device.	5-5
	5	Position control (internal position command) Control the position via internal position command; it can set pulse quantity and torque.	5-4
	6 (default value)	Position control (external pulse command) Control the position of servo motor via pulse command. Control the position via pulse quantity; control the speed via pulse frequency.	5-3
7	Speed control (pulse frequency command) Control the speed of servo motor via pulse frequency, but not control the position.	5-7	
P0-02 Sub mode2	Same as sub mode 1	The servo will enter sub mode2 when /C-SEL signal is effective.	5-10

5-2. Basic function setting

Parameter	Name	Reference
P5-10	Servo ON setting /S-ON	5-2-1
P0-05	Switch the motor rotate direction	5-2-2
P0-06	Motor stop mode setting	5-2-3
P4-06	Servo immediately stop torque	5-2-3
P5-12	Prohibit forward running /P-OT	5-2-4
P5-13	Prohibit reverse running /N-OT	5-2-4
P5-34	Power-loss brake /BK	5-2-5

5-2-1. Servo ON setting

When servo ON signal is ineffective, the servo motor cannot run.

Parameter	Signal	Setting	Explanation	Change	Effective
P5-10	/S-ON	n.0001 (default value)	When S11 is ON, servo motor powers on and enables to run.	Any	Repower on
		n.0010	Always effective, no need to wiring.		
/S-ON signal can be set to other input via parameter P5-10, please refer to chapter 5-12-1.					

5-2-2. Switch the motor rotate direction

Change the motor rotate direction without changing the motor wiring. The standard forward rotate direction is "CCW rotate" look at the load side.

"Reverse mode" will change the motor rotate direction.

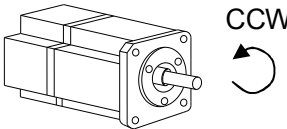
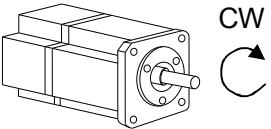
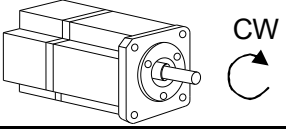
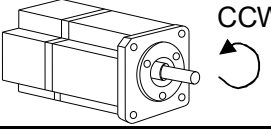
Mode	Forward rotate	Reverse rotate
Standard setting: CCW is forward rotate		
Reverse mode: CW is forward rotate		

■ Set the rotate direction

Parameter	Setting	Explanation	Change	Effective
P0-05	0 (default)	Standard setting (CCW is forward)	Servo stop	Repower on
	1	Reverse mode (CW is forward)		
After changing the direction, the servo received signal is negated, but it will not affect the direction of P-OT and N-OT.				

5-2-3. Overtravel Limit (P-OT & N-OT)

The limit switch can prevent the moving part on the machine out of the setting range. When the limit switch is connected to the servo and enabled, the servo will forced stop.

(1) Use the overtravel signal

Please connect P-OT and N-OT to the limit switch. Make sure to wiring as the following diagram when linear driving to avoid machine damage.

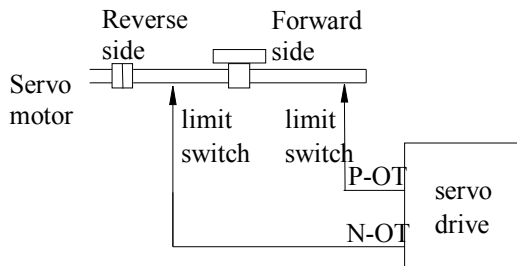

(2) Set the overtravel signal

Parameter	Signal	Setting	Explanation	Modify	Effective
P5-12	/P-OT	n.0013	SI3=ON, prohibit the forward running	Any	Repower on
		n.0003 (default value)	SI3=OFF, prohibit the forward running		
		n.0010	Always prohibit the forward running		
		n.0000	Do not use forward overtravel signal		
P5-13	/N-OT	Default value is n.0004, input signal from SI4 terminal. The setting method is the same as P-OT.		Any	Repower on

1. /P-OT, /N-OT can be changed to other terminal input via parameter P5-12 and P5-13. Please refer to chapter 5-12-1.
2. In position control, there is position offset pulse when stop the motor via overtravel signal. Please input clear signal /CLR to clear the offset.
3. In position control, if the servo still can receive pulse when stop the motor via overtravel signal, these pulses will accumulate until the servo alarm.

Notes: below is the default setting of P-OT and N-OT for each type.

Servo type	Parameter	Default setting
DS2-20P4 DS2-20P4-B DS2-20P7 DS2-20P7-B DS2-21P5-B	P5-12	n.0000
	P5-13	n.0000
DS2-20P4-A DS2-20P7-A DS2-21P5 DS2-21P5-A	P5-12	n.0003
	P5-13	n.0004

As the output terminals are different from each type, the default setting will be different.

(3) Motor stop mode when use overtravel signal

When use overtravel signal, please set the motor stop mode as the below table:

Parameter	Function	Setting range	Default value	Modify	Effective
P0-06.H	Motor stop mode when use overtravel signal	0~3	2	Servo OFF	Repower on

P0-06.H value	Explanation
0~1	Inertia stop. Keep on inertia motion after stop.
2	Decelerate stop. Change to zero clamp state after stop. Torque setting: P4-06 urgent stop torque
3	Decelerate stop. Change to inertia motion state after stop. Torque setting: P4-06 urgent stop torque.

- Notes: (1) P0-06.H=0,1, servo enable signal will be forced OFF when overtravel signal arrives.
P0-06.H=3, servo enable signal will be forced OFF after motor stop when overtravel signal arrives. P0-06.H=2, servo enable signal will not be forced OFF as long as the servo enable signal is always effective.
- (2) stop condition depends on rotate checking speed P5-02, unit rpm.

Related parameter settings:

P4-06	Urgent stop torque					
	Unit	Default value	Range	Suitable mode	Modify	Effective
	1% rated torque	300	0~300	All the	Servo	Immediately

				modes	OFF	
Notes: if this parameter set too small, the motor will stop slowly.						

5-2-4. Motor stop mode when servo OFF

DS2 series servo drive will close the servo enable as the following condition:

- The power is on, input signal is OFF (/S-ON)
- An alarm occurs (/ALM)
- Power is OFF.

Parameter	Description	Unit	Setting Range	Default Setting
P0-06.L	Motor stop mode when servo OFF	-	0~2	2

P0-06.L range	Explanation
0~2	Inertia stops. After stop, keep on inertia motion state.

Notes: DS2 series servo drive doesn't have built-in DB brake. So no matter what value P0-06.L is, servo will keep on inertia motion after stop.

5-2-5. Power-off Brake (BK)

It is used when servo drive controls the vertical shaft. The function of power-off brake is the moveable part will not shift when servo is OFF.

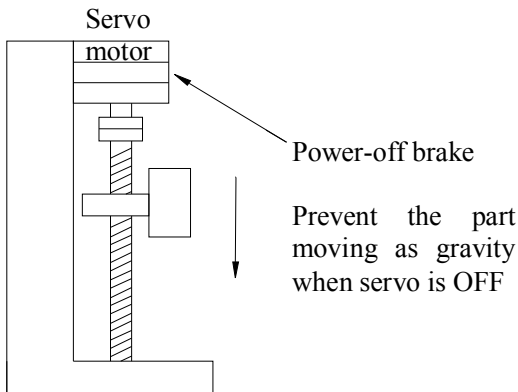

The brake built into the MS series servomotor with brakes is a de-energization brake, which is used only to hold and cannot be used for braking. Use the holding brake only to hold a stopped motor. Brake torque is about 120% of the rated motor torque.

(1) Wiring Example

The ON/OFF circuit of brake includes sequence signal /BK and brake power. The following diagram shows a standard wiring example.

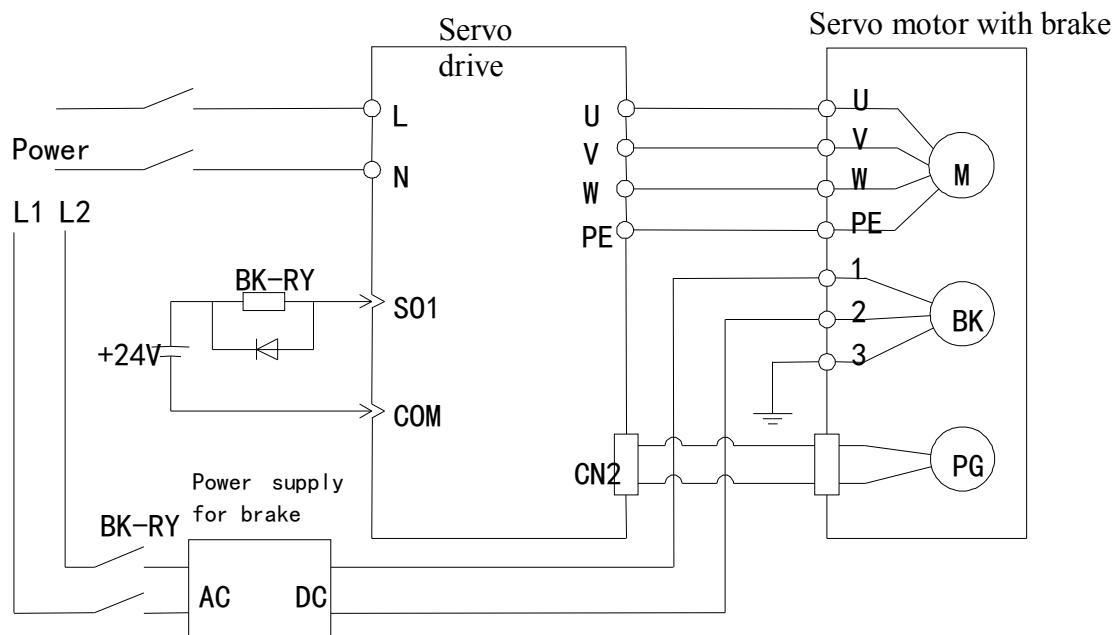

Note: the working voltage of brake is DC 24V, current is about 0.6A.

In above diagram, BK signal is output from S01, set parameter P5-34 to n.0011.

(2) Brake signal

The signal controls the brake. Do not have to connect the signal if the motor without brake.

Parameter	Signal	Type	Default	Explanation	Modify	Effective
P5-34	/BK	Output	n.0000	Need to distribute	Any	Re-power on

/BK signal can output from output terminal via setting parameter P5-34, please refer to chapter 5-12-2.

(3) Servo OFF delay time (after servo motor stop)

If the machine moves slightly due to gravity because of the brake has action delay time. Please adjust the time as below parameter.

P5-06	Servo OFF delay time (brake command)					
	Unit	Default	Range	Suitable mode	Modify	Effective
	1ms	0	0~500	All the modes	Servo OFF	Immediately

This parameter is used to set the output time from the brake control signal /BK to the servo OFF operation (servomotor output stop).

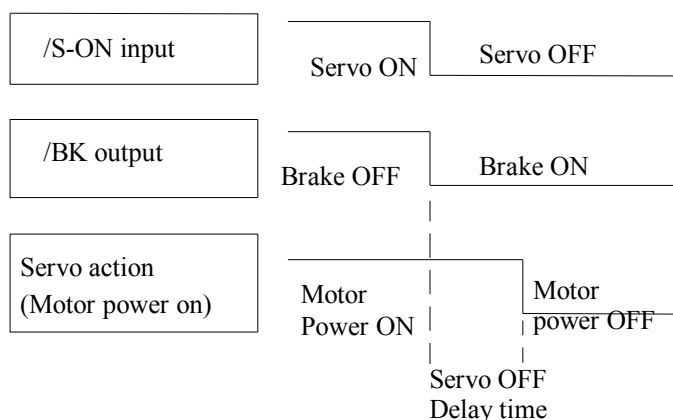

With the standard setting, the servo will be OFF when the /BK signal (brake operation) output. However, depending on machine configuration and brake characteristics, there is a period from /BK signal output to brake action. During the time, motor will not output torque, brake doesn't brake, the machine may move slightly due to gravity. Now, we use

parameter P5-06 to delay the servo OFF, make sure the servo isn't OFF until the brake action in order to delete the machine moving.

Note: this parameter is the time when motor stop and TGON is invalid.

(4) Brake ON parameter (When servo motor is rotating)

The brake action setting during the motor is rotating: parameter P5-07, P5-08.

Notes: the motor will power OFF when alarm occurs. The machine will move as gravity until the brake action.

Set below parameters in order to use brake when motor speed decreases to setting value or waiting time ends.

P5-07	Brake command output speed					
	Unit	Default	Range	Suitable mode	Modify	Effective
	rpm	100	0~5000	All the modes	Servo OFF	Immediately
P5-08	Brake command waiting time					
	Unit	Default	Range	Suitable mode	Modify	Effective
	1ms	500	10~1000	All the modes	Servo OFF	Immediately

Set the brake time when servo OFF caused by /S-ON signal or alarm.

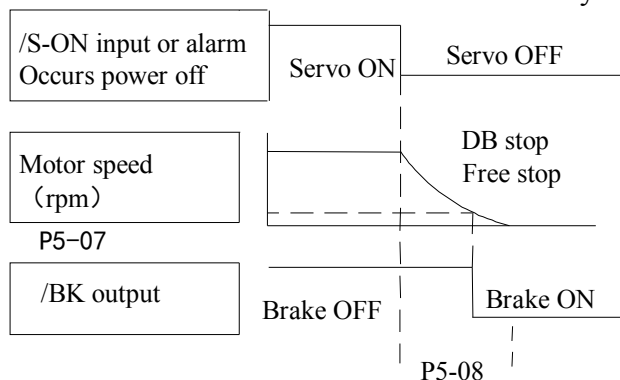

The brake is used to protect the position. The brake must be effective at suitable time when servo motor stop. Users can adjust the parameters according to the machine action.

The /BK signal from ON to OFF under either of the following conditions:

1. Motor speed drops below the value of P5-07 after servo OFF.
2. over the time of P5-08 after servo OFF.

The real speed is max speed (P3-09) even set the speed higher than max in P5-07.

5-3. Position mode (external pulse command)

Below parameters are used in position mode with pulse.

Basic parameter		
Parameter	Name	Reference
P0-01	Control mode selection	5-3-1
P2-00	Pulse command mode	5-3-2
P2-02	Electronic gear ratio (numerator)	5-3-3
P2-03	Electronic gear ratio (denominator)	
P5-10	Servo ON signal /S-ON	5-2-1

Other available parameters			
Key words	Parameter	Name	Reference
Command filter	P2-01	Position command filter selection	5-3-4
Clear error pulse	P5-24	Pulse error clear	5-3-5

Positioning finish	P5-28	Positioning finish signal output /COIN	5-3-6
	P5-00	Positioning finish width	
Positioning near	P5-36	Positioning near signal outpu /NEAR	5-3-7
	P5-04	Positioning near signal width	
Prohibit pulse	P5-22	Command pulse prohibition /INHIBIT	5-3-8

5-3-1. Control mode selection

Parameter	Setting value	Meaning	Modify	Effective
P0-01	6	Position control (external pulse)	Servo OFF	Immediately
Function: control the position by the external pulse command				

5-3-2. Pulse command

5-3-2-1. Pulse mode selection

Parameter	Setting value	Command mode	Suitable mode	Modify	Effective
P2-00	0	CW, CCW mode	6, 7	Servo OFF	Re-power on
	2	Pulse+direction			

Note: DS2 series (hardware version 3.2) cannot support AB phase pulse.

5-3-2-2. Explanation of command pulse

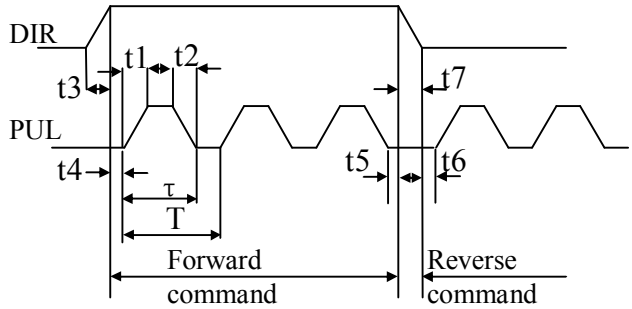
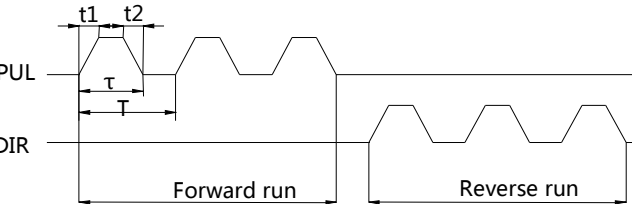
Command pulse mode	Electrical specification	Remark
Direction+pulse (DIR+PUL signal) Max frequency: Bus drive is 500kbps. Transistor open circuit is 200kbps.	 <p> $t1, t2 \leq 0.1\mu s$ $t3, t7 \leq 0.1\mu s$ $t4, t5, t6 > 3\mu s$ $\tau \geq 2.5\mu s$ $(\tau/T) \times 100 = 40\% \sim 60\%$ </p>	Direction (DIR) 1= forward command 0= reverse command
CW, CCW mode Max frequency: Bus drive is 500kbps. Transistor open circuit is 200kbps.	 <p> $t1, t2 \leq 0.1\mu s$ $\tau \geq 2.5\mu s$ $(\tau/T) \times 100 = 40\% \sim 60\%$ </p>	CW: PUL=pulses DIR=0 CCW: PUL=0 DIR=pulses

5-3-2-3. Signal connection

The signal connection please refer to chapter 3-2-4.

5-3-3. Electronic gear ratio

The electronic gear function is set any value for motor moving quantity corresponding to input pulse command. The host device which sends command doesn't need to consider the machine deceleration ratio and encoder pulse quantity.

Not use electronic gear

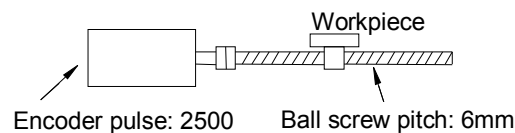

The workpiece moves 10mm

One rotation is 6mm
 $10 \div 6 = 1.6666$
 2500 × 4 pulse finishes one rotation
 Command input 16666 pulses
 Calculate these values in the host controller

Use electronic gear

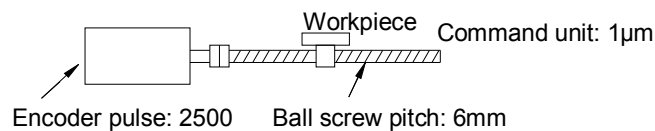

Define the machine condition and command unit by electronic gear

The workpiece moves 10mm

Command unit is 1 µm

$$\frac{10\text{mm}}{1\mu\text{m}} = 10000 \text{ pulse}$$

5-3-3-1. Parameter

P2-02	Electronic gear (numerator)					
	Unit	Default	Range	Suitable mode	Modify	Effective
	—	1	1~65535	6	Any	Immediately
P2-03	Electronic gear (denominator)					
	Unit	Default	Range	Suitable mode	Modify	Effective
	—	1	1~65535	6	Any	Immediately

5-3-3-2. Set the electronic gear

Calculate the electronic gear ratio (B/A) using the following steps:

Step	Content	Explanation
1	Confirm the machine specification	Confirm the deceleration ratio, ball screw distance, pulley diameter
2	Confirm the encoder pulse	Confirm the servo motor encoder pulses
3	Set the reference unit	Set the actual distance or angle corresponding to 1 pulse of the command controller

4	Calculate the moving value the load shaft rotates 1 circle	Calculate the actual unit value the load shaft rotates 1 circle based on reference unit
5	Calculate the electronic gear ratio	Calculate the electronic gear ratio based on the formula (B/A)
6	Set the parameters	Set the result as the electronic gear ratio

1. Formula:
 Suppose the machine deceleration ratio of motor shaft and load shaft is m/n, calculate the electronic gear ratio as the below formula:
 (when servo motor shaft rotates m circles, load shaft rotates n circles)

$$\text{Electronic gear ratio} = \frac{B}{A} = \frac{P2-02}{P2-03}$$

$$= \frac{\text{Encoder pulses} \times 4}{\text{unit value of load shaft rotates 1 circle}} \times \frac{m}{n}$$
 If it exceeds the setting range, please reducible the molecular and denominator in the setting range. The reducible will not affect the using.

2. Reference unit doesn't mean the precision
 Refine the reference unit based on machine precision can improve the servo positioning precision. For example: in the application of screw, the machine precision can up to 0.01mm, so the reference unit 0.01mm is more accurate than 0.1mm.

5-3-3-3. Example of setting the electronic gear

The example for different loads:

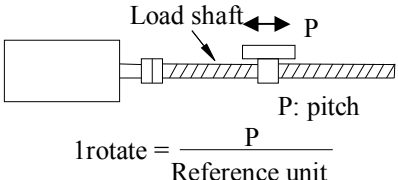
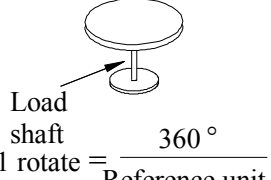
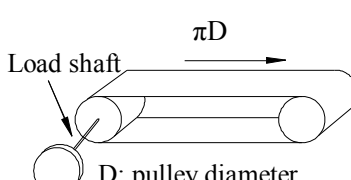
Step	Ball screw	Round table	Belt + pulley
	 <p>1 rotate = $\frac{P}{\text{Reference unit}}$</p>	 <p>1 rotate = $\frac{360^\circ}{\text{Reference unit}}$</p>	 <p>1 rotate = $\frac{\pi D}{\text{Reference unit}}$</p>
1	Ball screw pitch: 6mm Machine deceleration ratio: 1/1	1-circle rotate angle: 360° Deceleration ratio: 3/1	Pulley diameter: 100mm Deceleration ratio: 2/1
2	2500P/R	2500P/R	2500P/R
3	1 reference unit: 0.001mm	1 reference unit: 0.1°	1 reference unit: 0.02mm
4	6mm/0.001mm = 6000	360/0.1 = 3600	314mm/0.02mm = 15700
5	$\frac{B}{A} = \frac{2500 \times 4}{6000} \times \frac{1}{1}$	$\frac{B}{A} = \frac{2500 \times 4}{3600} \times \frac{3}{1}$	$\frac{B}{A} = \frac{2500 \times 4}{15700} \times \frac{2}{1}$
6	$\frac{P2-02}{P2-03} = \frac{10000}{6000} = \frac{5}{3}$	$\frac{P2-02}{P2-03} = \frac{30000}{3600} = \frac{25}{3}$	$\frac{P2-02}{P2-03} = \frac{20000}{15700} = \frac{200}{157}$

5-3-4. Position command filter

The servo can filter the command pulse at certain frequency.

Filter mode selection: select the filter as the following parameters

P2-01	Select the position command filter					
	Unit	Default	Range	Suitable mode	Modify	Effective
	—	0	0~1	6, 7	Servo OFF	Re-power on

Select 1-time delay feature or moving average filter.

P2-01	Content
0	First-order inertia filter
1	Smooth filter

Set the filter time:

P2-04	Position command filter time parameters					
	Unit	Default	Range	Suitable mode	Modify	Effective
	ms	0	0~100	6, 7	Servo OFF	Re-power on

Addition:

The comparison of P2-04 in First-order inertia filter and smooth filter mode:

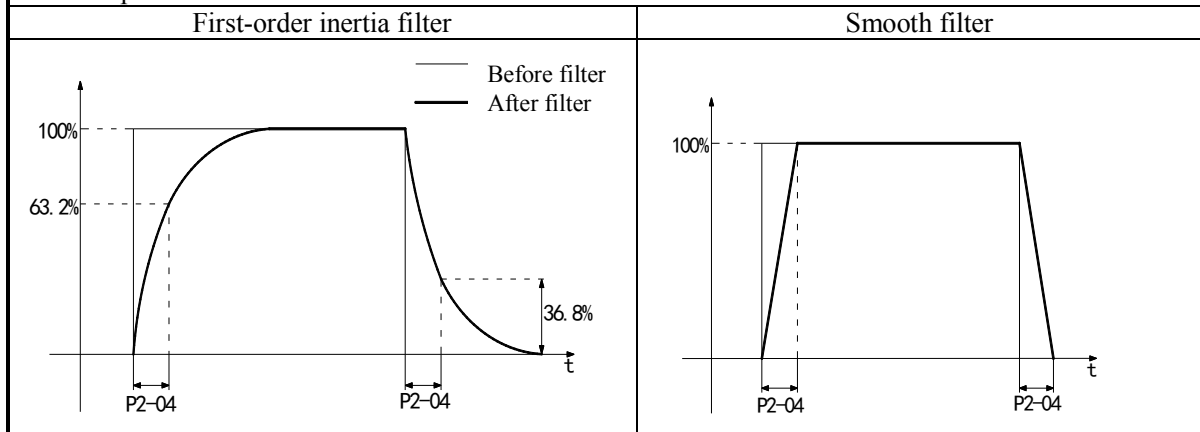

5-3-5. Pulse error clear (/CLR)

Pulse error: the difference between command pulse of controller (such as PLC) and feedback pulse of servo in position mode. Its unit is 1 reference unit; it is related to the reference unit of electronic gear ratio.

Parameter	Signal	Default	Meaning	Suitable mode	Modify	Effective
P5-24	/CLR	n.0000	Need distribution	5, 6	Any	Re-power on

Notes: 1. /CLR can be used as input terminal, please refer to chapter 5-12-1.
2. Monitor the pulse error via U-08.

Function: after set on /CLR signal, the error counter is set to 0, position-loop given position is set to current position. Clear the pulse error at the rising edge of /CLR signal.

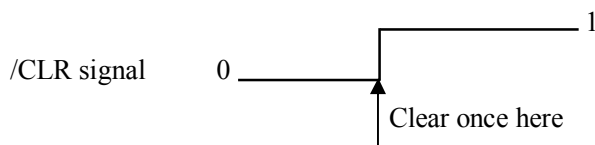

So after the /CLR signal is ON, the error will accumulate if the servo still receive pulses.

5-3-6. Positioning complete (/COIN)

Use the signal when the controller needs to confirm the completion of positioning.

Parameter	Signal	Default	Meaning	Suitable mode	Modify	Effective
P5-28	/COIN	n.0001	Output positioning complete signal from SO1	5, 6	Any	Re-power on

Note: /COIN can be output from other terminals, please refer to chapter 5-12-3.

P5-00	Width of positioning complete
-------	-------------------------------

	Unit	Default	Range	Suitable mode	Modify	Effective
	1 reference unit	7	0~250	5, 6	Servo OFF	Immediately

Function: when the pulse error value is lower than P5-00, output /COIN signal. Monitor the pulse error value via U-08.

5-3-7. Positioning near (/NEAR)

Positioning near signal means the servo motor is near the positioning complete. It prompts the device to prepare the next operation.

Parameter	Signal	Default	Meaning	Suitable mode	Modify	Effective
P5-36	/NEAR	n.0000	Need to distribute	5, 6	Any	Re-power on

Note: /NEAR can be output from terminal by setting P5-36, please see chapter 5-12-3.

P5-04	Width of positioning near signal					
	Unit	Default	Range	Suitable mode	Modify	Effective
	1 reference unit	50	0~10000	5, 6	Servo OFF	Immediately

Function: when the pulse error signal is lower than P5-04, output /NEAR signal. Set the parameter wider than positioning complete signal. Monitor the pulse error value via U-08.

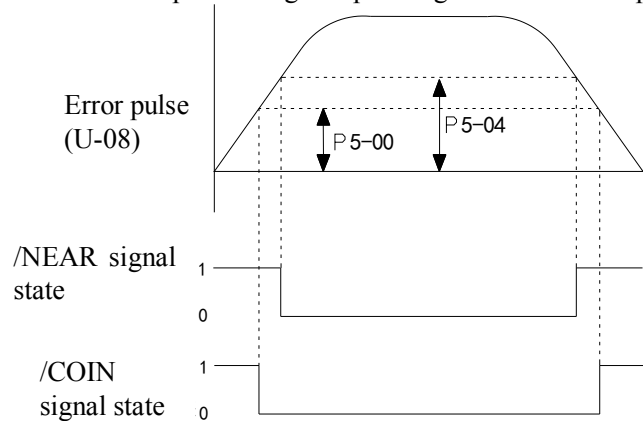

Note: here is signal state, but not terminal state.

5-3-8. Command pulse prohibition (/INHIBIT)

To stop the command pulse counts in position control mode. When /INHIBIT signal is ON, the command pulse stop counting.

Input signal setting:

Parameter	Signal	Default	Meaning	Suitable mode	Modify	Effective
P5-22	/INHIBIT	n.0000	Need to distribute	5, 6	Any	Re-power on

Note: /INHIBIT can be input from input terminal by setting P5-22. Please refer to chapter 5-12-1

5-4. Position mode (internal position mode)

Parameter		
Parameter	Name	Reference
P0-01	Control mode selection	5-4-1
P2-10	Internal position given mode	5-4-2
P2-11~P2-90	Internal 1~16 segment position parameters	5-4-3
P5-25	Change the step signal /CHGSTP	5-4-4
P5-22	Pause current signal /INHIBIT	5-4-5
P5-21	Skip current signal /Z-CLAMP	5-4-6
P5-10	Servo ON signal /S-ON	5-2-1

Other parameters			
Key words	Parameter	Name	Reference
Find the origin	P2-94	The quantity pass through the Z phase signal after leaving the limit switch	5-4-7
	P2-95	The speed near the limit switch	
	P2-96	The speed leave the limit switch	
	P5-17	/SPD-D: define the origin in position mode	
	P5-18	/SPD-A: find the reference origin at forward side in position mode	
	P5-19	/SPD-B: find the reference origin at reverse side in position mode	
Pulse error clear	P5-24	Pulse error clear	5-3-5
Positioning complete	P5-28	Positioning complete signal output /COIN	5-3-6
	P5-00	Positioning complete width	
Positioning near	P5-36	Positioning near signal output /NEAR	5-3-7
	P5-04	Positioning near signal width	

5-4-1. Control mode selection

Parameter	Default	Meaning	Modify	Effective
P0-01	5	Internal position mode control	Servo OFF	Immediately

Function: control the position with the value in servo internal register

5-4-2. Internal position given mode

Parameter	Content	Unit	Default	Suitable mode	Modify	Effective
P2-10	Internal position mode setting	—	n.0000	5	Servo OFF	Re-power on
	Parameter setting	Function	Default	Range		
	n.□XXX	No meaning				
	n.X□XX	Wait mode	0	0~1		
	n.XX□X	Change step mode	0	0~2		

n.XXX□	Positioning mode	0	0~1
--------	------------------	---	-----

Mode explanation:

(1) Wait mode

n.X□XX	Meaning
0	Wait for the completion of positioning
1	Not wait for the completion of positioning

Notes: the wait mode means whether the drive is waiting for the completion of positioning in internal position setting mode. This is effective in any change step mode.

Wait mode = 0, adjust time = 0ms	Wait mode = 0, adjust time > 0ms
<p>After the drive output 1-segment position command, it will wait for the completion of motor positioning, and then start the next position command at once. T1 is positioning time, which means the time from pulse output complete to the output of positioning completion signal.</p>	<p>After the drive output 1-segment position command, it will wait for the completion of motor positioning, and pass the adjust time, then start the next position command. T1 is positioning time, t2 is adjust time. Refer to parameter P2-14.</p>
Wait mode = 1, adjust time = 0ms	Wait mode = 1, adjust time > 0ms
<p>After the drive output 1-segment position command, it will not wait for the completion of motor positioning, and start the next position command at once.</p>	<p>After the drive output 1-segment position command, it will not wait for the completion of motor positioning, but pass the adjust time, and then start the next position command. T2 is adjust time. Refer to parameter P2-14.</p>

(2) Change step mode

n.XX□X	Explanation
0: Change the step when signal is ON, recycling	

	<p>$t1=P2-14, t2=P2-19$</p> <ol style="list-style-type: none"> If /CHGSTP is ON, servo will run segment 1 and 2. If /CHGSTP is OFF in one segment, servo will finish this segment and stop running the next segment.
<p>1: Change the step at the rising edge of the signal, single-step run</p>	<p>Suppose there are 2 segments. $t1=P2-14$ In this mode, the adjust time is ineffective. The servo will run the next command once the current pulse is finished.</p>
<p>2: Start at the rising edge of the signal, sequential run all, not recycling</p>	<p>Suppose there are 2 segments. $t1=P2-14$ /CHGSTP signal is ineffective when one cycle has not been finished, such as the second /CHNGSTP signal in the diagram.</p>

(3) Positioning mode

n.XXX□	Meaning
0	Relative positioning
1	Absolute positioning
0: relative positioning	1: absolute positioning (take the accumulate position origin as the absolute positioning origin)

5-4-3. Position parameters from segment 1 to 16

P2-5(n+1)+1	Pulse number (low bit)					
	Unit	Default	Range	Suitable mode	Modify	Effective
	1 pulse	0	-9999~9999	5	Servo OFF	Immediately
P2-5(n+1)+2	Pulse number (high bit)					
	Unit	Default	Range	Suitable mode	Modify	Effective
	10000 pulses	0	-9999~9999	5	Servo OFF	Immediately
P2-5(n+1)+3	Speed					
	Unit	Default	Range	Suitable mode	Modify	Effective
	0.1rpm	0	0~50000	5	Servo OFF	Immediately
P2-5(n+1)+4	Adjust time					
	Unit	Default	Range	Suitable mode	Modify	Effective
	1 ms	0	0~65535	5	Servo OFF	Immediately
P2-5(n+1)+5	Filter time					
	Unit	Default	Range	Suitable mode	Modify	Effective
	0.1ms	0	0~65535	5	Servo OFF	Immediately
<p>Notes: 1. Set pulse number = pulse number (high bit) × 10000 + pulse number (low bit). 2. In formula P2-5(n+1) + 1, n is the segment no. of internal position; the range is 1~16. 3. If one of the segment speed is zero, servo will skip this segment and run the next segment. 4. In relative positioning mode, if one segment speed is not zero but the pulse number is zero, the motor will not run, but the wait mode is effective. The servo will run the next segment when the adjust time is out. 5. In absolute positioning mode, if one segment speed is not zero but the pulse number is zero, the motor will return to the reference origin with the speed of this segment. 6. In absolute positioning mode, if 2 consecutive segments speed are not zero, but the pulse number is the same, the servo motor will not run but the wait mode is effective.</p>						

5-4-4. Change step (/CHGSTP)

Parameter	Signal	Type	Default	Meaning	Suitable mode	Modify	Effective
P5-25	/CHGSTP	Input	n.0000	Need distribute	5	Any	Re-power on
Note: /CHGSTP can be distributed to other input terminal by setting the parameter P5-25. Refer to chapter 5-12-1.							

5-4-5. Pause current signal (/INHIBIT)

When /INHIBIT signal is ON, the internal position pulse will stop in internal position mode. When /INHIBIT signal is OFF, the motor will continue running this stage.

Input signal setting:

Parameter	Signal	Default setting	Meaning	Suitable mode	Modify	Effect
P5-22	/INHIBIT	n.0000	Need to distribute	5, 6	Any	Repower on
1./INHIBIT signal is distributed to I/O terminal via P5-22, refer to chapter 5-12-1.						

5-4-6. Skip current signal (/ZCLAMP)

When /ZCLAMP signal is triggered in internal position mode, cancel the current stage running, enter the next stage as different conditions of change step mode.

/Z-CLAMP signal	Change step mode	Execution
	0	Cancel current stage, execute the next stage at once
	1	Cancel current stage, execute the next stage when the change step signal is ON
	2	Cancel current stage, execute the next stage at once

Input signal setting:

Parameter	Signal	Type	Default	Meaning	Suitable mode	Modify	Effect
P5-21	/Z-CLAMP	Input	n.0000	Need to distribute	3, 4, 7	Any	Re-power on

1./Z-CLAMP can be distributed to input terminal by P5-21. Refer to chapter 5-12-1.

2./Z-CLAMP is zero clamp function in speed mode.

5-4-7. Reference origin

(1) Find the reference origin

To find out the physical origin of working table and make it as the coordinates origin of point position control. Users can select finding reference origin at forward or reverse side.

Function setting:

P2-94 n.XX□X	Unit	Default	Range	Suitable mode	Modify	Effect
	-	0	0~1	5, 6	ServoOFF	Re-power on

Note: P2-94=0, find reference origin function is invalid. P2-94=1, this function is valid.

Signal setting:

Parameter	Signal	Type	Default	Meaning	Suitable mode	Modify	Effective
P5-18	/SPD-A	Input	n.0000	Need to distribute	3, 5, 6	Any	Re-power on
P5-19	/SPD-B	Input	n.0000	Need to distribute	3, 5, 6	Any	Re-power on

1. /SPD-A, /SPD-B can be distributed to the input terminal via parameter P5-18, P5-19, refer to chapter 5-12-1.

2. In position mode, /SPD-A can trigger the forward side to find the reference origin, /SPD-B can trigger the reverse side to find the reference origin.

3. In internal speed mode (mode 3), /SPD-A and /SPD-B auto-switch to internal speed selection signal.

Related parameter setting:

P2-94	The quantity pass the Z phase signal after leaving the limit switch						
	Unit	Default	Range	Suitable mode	Modify	Effective	
	Number	2	1~F	5, 6	Servo OFF	Immediately	
P2-95	The speed hitting the proximity switch						
	Unit	Default	Range	Suitable mode	Modify	Effective	
	0.1rpm	600	0~50000	5, 6	Servo OFF	Immediately	
P2-96	The speed leaving the proximity switch						
	Unit	Default	Range	Suitable mode	Modify	Effective	
	0.1rpm	100	0~50000	5, 6	Servo OFF	Immediately	

Detailed explanation:

Find reference origin diagram:

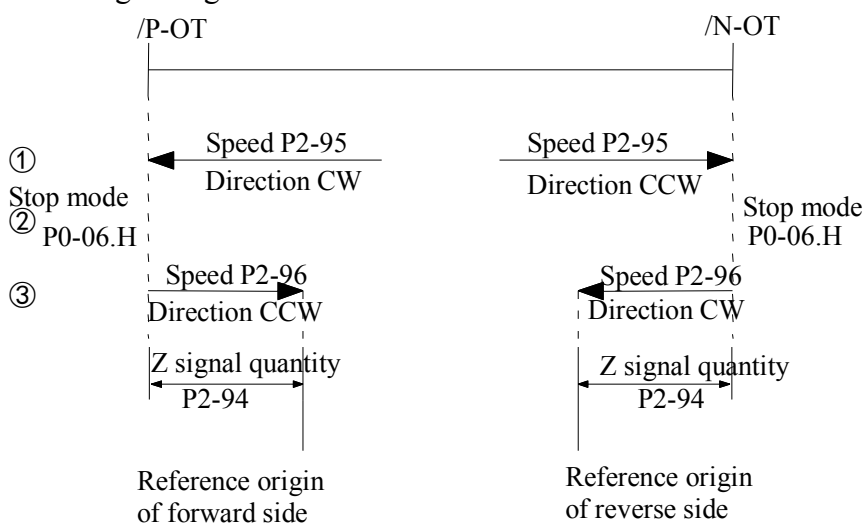

The timing diagram of finding reference origin of forward side:

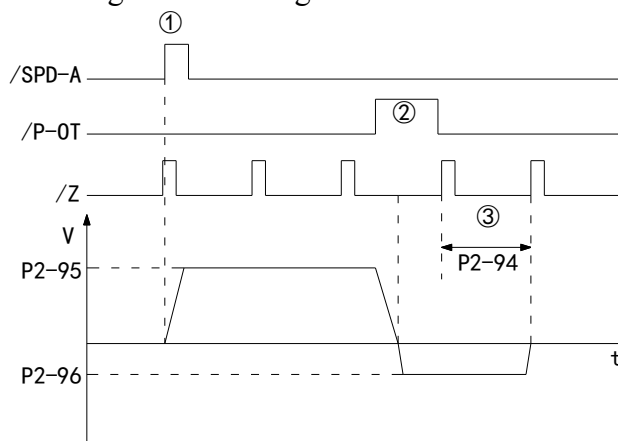

Steps:

1. Install limit switch at forward and reverse side. At the rising edge of /SPD-A, motor runs forward at the speed of P2-95 to find the reference origin of forward side.
2. After the working table hit the limit switch, the motor stop as the mode set by parameter P0-06.H.
3. Motor leaves the limit switch at the speed of P2-96. After the working table left the limit switch, the motor run at the Z phase signal position of No.n optical encoder. This position is considered as the coordinates origin, n is decided by parameter P2-94.

(2) Define the reference origin

Function:

In external pulse command position mode (mode 6) and internal position mode (mode 5), define the current position as the reference origin at the rising edge of /SPD-D.

Signal setting:

Parameter	Signal	Type	Default	Meaning	Suitable mode	Modify	Effective
P5-17	/SPD-D	Input	n.0000	Need distribute	3, 5, 6	Any	Re-power on

1. /SPD-D can be distributed to input terminal by P5-17. Refer to chapter 5-12-1.
 2. In internal speed mode (mode 3), /SPD-D auto-switch to the direction select signal of internal speed.

The reference origin defined by the two modes will be considered as the origin of absolute position control.

5-5. Speed control (analog voltage command)

Note: only DS2-2□P□-A and DS2-2□P□-B support this mode.

Basic parameters		
Parameter	Name	Reference
P0-01	Select the control mode	5-5-1
P3-00	Analog value of rated speed	5-5-2
P5-10	Servo ON signal /S-ON	5-2-1

Other parameters			
Key words	Parameter	Name	Reference
Zero drift adjustment	F1-03	Analog voltage speed command offset auto-adjustment	5-5-3
Proportion action	P5-11	P-CON	5-5-4
Zero clamp	P5-21	Zero clamp /ZCLAMP	5-5-5
	P5-01	Zero clamp speed	
Speed coincidence checking	P5-29	/V-CMP speed coincidence checking	5-5-6
	P5-03	Coincidence speed signal checking width/V-CMP	
Torque limit	P4-02	Forward torque limit	5-5-7
	P4-03	Reverse torque limit	
	P0-07	T-REF distribution	
	P4-04	Forward external torque limit	
	P4-05	Reverse external torque limit	
	P5-15	Forward external torque limit /P-CL	
	P5-16	Reverse external torque limit /N-CL	
Soft start	P3-05	Soft start acceleration time	5-5-8
	P3-06	Soft start deceleration time	
Filter	P3-07	Speed command filter time	5-5-9
	P3-08	Speed feedback filter time	
Death area	P3-10	Speed command death area input voltage	5-5-10

5-5-1. Control mode selection

Parameter	Set value	Meaning	Modify	Effective
P0-01	4	Analog voltage command speed control	Servo OFF	Immediately

Function: control the speed by the signal (analog voltage command) input from V-REF terminal

5-5-2. Analog value of rated speed

P3-00	Analog value of rated speed					
	Unit	Default	Range	Suitable mode	Modify	Effective
	0.01V/rated speed	1000	150~3000	4	Servo OFF	Immediately

Function: the speed command voltage (V-REF) to run the servo motor at rated speed.
Such as: P3-00=500 means the motor run at rated speed when analog input voltage = 5.00V
P3-00=800 means the motor run at rated speed when analog input voltage = 8.00V.

Analog command input please refers to chapter 3-2-4.

5-5-3. Speed command offset auto-adjustment (F1-03)

When the servo is in analog voltage speed mode, even if the command voltage is 0V, motor will run at very low speed. The micro-motion will happen when the command voltage micro-offset (mV) of host controller or external circuit occurs. Auto-adjust the command offset by operate panel of servo. Refer to chapter 4-4-2.

5-5-4. Proportion action command (/P-CON)

Parameter	Signal	Type	Default	State	Meaning	Modify	Effective
P5-11	/P-CON	Input	n.0000	Effective	Run in P control mode	Any	Re-power on
				Ineffective	Run in PI control mode		

1. /P-CON is the speed control mode signal selected from PI (proportion integral) and P (proportion).
 2. If set to P control mode, the motor rotate and micro-vibration caused by speed command input drift can be decreased. But the servo stiffness will decrease.
 3. /P-CON signal can be distributed to input terminal via parameter P5-11. Refer to chapter 5-12-1.

5-5-5. Zero clamp (/ZCLAMP)

(1) Function

This function is used when host controller uses speed command input and the servo system isn't configured the position loop. In other words, the function will be used when the motor must stop and enter lock state even the V-REF input voltage is not zero. After the zero clamp function is ON, servo will configure the temporary position loop inside, motor will clamp in ± 1 pulse. Motor will return to zero clamp position even the motor is rotating with external force.

(2) Input signal setting

Parameter	Signal	Type	Default	Meaning	Suitable mode	Modify	Effective
P5-21	/Z-CLAMP	Input	n.0000	Need to distribute	3, 4, 7	Any	Re-power on

Note: /Z-CLAMP signal is distributed to input terminal by parameter P5-21, refer to chapter 5-12-1.

(3) Parameter setting

P5-01	Speed of zero clamp						
	Unit	Default	Range	Suitable mode	Modify	Effective	
	Rpm	10	0~300	3, 4, 7	Servo OFF	Immediately	

Zero clamp will act when meets the following conditions:

- Speed control (submode 3 or 4)
- Set ON /ZCLAMP
- Speed command value is less than the value of P5-01

5-5-6. Speed coincidence checking (/V-CMP)

When motor speed is equal to the command speed, servo outputs speed coincidence signal (V-CMP).

Parameter	Signal	Type	Default	Meaning	Suitable mode	Modify	Effective
P5-29	/V-CMP	Output	n.0000	Need to distribute	3, 4, 7	Any	Re-power on

Note: /V-CMP signal can be distributed to output terminal by parameter P5-29. Refer to chapter 5-12-3.

P5-03	Speed coincidence signal width					
	Unit	Default	Range	Suitable mode	Modify	Effective
	rpm	10	1~250	3, 4, 7	Servo OFF	Immediately

If the difference between motor speed and command speed is less than the value of P5-03, servo outputs /V-CMP signal.

5-5-7. Torque limit

5-5-7-1. Internal torque limit (output torque max value limit)

The function is to limit the max output torque by parameters.

P4-02	Forward torque limit					
	Unit	Default	Range	Suitable mode	Modify	Effective
	1%	300	0~300	All modes	Servo OFF	Immediately
P4-03	Reverse torque limit					
	Unit	Default	Range	Suitable mode	Modify	Effective
	1%	300	0~300	All modes	Servo OFF	Immediately

1. This parameter is always effective, if this parameter value is less than external torque limit value, the final limit value is this parameter.
2. The unit is percent of the motor rated torque; the default value is 300%. The real output torque is different for each type.

5-5-7-2. External torque limit (via input signal)

This function is used in machine motion or timing torque limit. For example: press stop action or robot workpiece protection.

The torque limit value will be effective when the input signal is ON.

P4-04	Forward external torque limit					
	Unit	Default	Range	Suitable mode	Modify	Effective
	1%	100	0~300	All modes	Servo OFF	Immediately
P4-05	Reverse external limit					
	Unit	Default	Range	Suitable mode	Modify	Effective
	1%	100	0~300	All modes	Servo OFF	Immediately

The unit is the percent of motor rated torque; the default value is 100%.

Parameter	Signal	Type	Default	Meaning	Suitable mode	Modify	Effective
P5-15	/P-CL	Input	n.0000	Need to distribute	All modes	Any	Re-power on
P5-16	/N-CL	Input	n.0000	Need to distribute	All modes	Any	Re-power on

Notes: /P-CL, /N-CL can be distributed to input terminal by parameter P5-15, P5-16. Refer to chapter 5-12-1.

Function realization:

Signal	State	Meaning	Effective limit value
/P-CL	0	Forward external torque limit OFF	P4-02
	1	Forward external torque limit ON	Min value between P4-02 and P4-04
/N-CL	0	Reverse external torque limit OFF	P4-03
	1	Reverse external torque limit ON	Min value between P4-03 and P4-05

5-5-7-3. External torque limit (via analog voltage command)

T-REF terminal is used as analog voltage command terminal. Please note in external analog torque control mode, this function cannot be used.

Parameter	Function	Set value	Meaning	Modify	Effective
P0-07	Distribute function to T-REF	1	Make T-REF as external torque limit input	Servo OFF	Re-power on

1. For analog voltage command input of torque limit. Get the absolute value of the voltage, the torque limit value based on the absolute value is suitable for forward and reverse direction.
2. When it is used as torque limit, the value is related to voltage command and P4-00. For example, P4-00=1000, T-REF voltage command is 5.0V, the torque limit value is 50% of rated torque.

5-5-7-4. External torque limit (via external input + analog voltage)

External torque limit via external input and analog voltage can be used together. Input analog voltage signal from T-REF. the torque limit function cannot be used when servo is in analog command torque control mode.

Use /P-CL and /N-CL signal when limit torque via external input.

(1) Parameters

Parameter	Function	Set value	Meaning	Modify	Effective
P0-07	T-REF function distribution	3	When P-CL, N-CL is ON, make T-REF as external torque limit input.	Servo OFF	Re-power on

P4-04	Forward external torque limit					
	Unit	Default	Range	Suitable mode	Modify	Effective
	1%	100	0~300	All modes	Servo OFF	Immediately
P4-05	Reverse external torque limit					
	Unit	Default	Range	Suitable mode	Modify	Effective
	1%	100	0~300	All modes	Servo OFF	Immediately

Note: the unit is the percent of motor rated torque, the default value if 100%.

(2) Input signal setting

Parameter	Signal	Type	Default	Meaning	Suitable mode	Modify	Effective
P5-15	/P-CL	Input	n.0000	Need to distribute	All modes	Any	Re-power on
P5-16	/N-CL	Input	n.0000	Need to distribute	All modes	Any	Re-power on

Note: /P-CL, /N-CL signal can be distributed to input terminal by parameter P5-15, P5-16. Refer to chapter 5-12-1.

(3) Function realization

Signal	State	Meaning	Limit value
/P-CL	0	Forward external torque limit OFF	P4-02
	1	Forward external torque limit ON	The min value among P4-02, P4-04 and analog voltage command

/N-CL	0	Reverse external torque limit OFF	P4-03
	1	Reverse external torque limit ON	The min value among P4-03, P4-05 and analog voltage command

5-5-7-5. Output torque up to limit value signal

The signal means the motor output torque reaches limit value.

Parameter	Signal	Type	Default	Meaning	Suitable mode	Modify	Effective
P5-32	/CLT	Output	n.0000	Need to distribute	All modes	Any	Re-power on

Note: /CLT signal can be distributed to output terminal by parameter P5-32. Refer to chapter 5-12-3.

5-5-8. Soft start

Soft start can transform the step speed command to command with acceleration/deceleration.

P3-05	Soft start acceleration time						
	Unit	Default	Range	Suitable mode	Modify	Effective	
	1ms	0	0~65535	3, 4, 7	Servo OFF	Immediately	
P3-06	Soft start deceleration time						
	Unit	Default	Range	Suitable mode	Modify	Effective	
	1ms	0	0~65535	3, 4, 7	Servo OFF	Immediately	

1. Enable to do smooth speed control when input step speed command or choose internal speed. Other cases please set to 0.
2. acceleration/deceleration time is from stop state to rated speed but not from current speed to target speed.
P3-05: the time from stop state to rated speed.
P3-06: the time from rated speed to stop state.

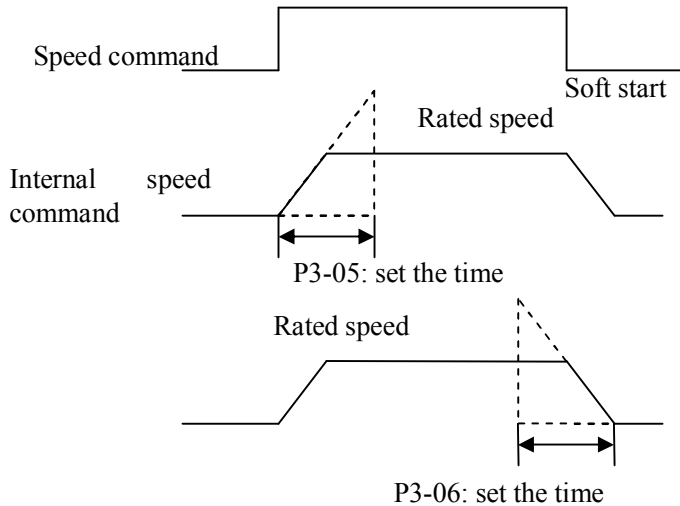

5-5-9. Filter

P3-07	speed command filter time						
	Unit	Default	Range	Suitable mode	Modify	Effective	
	0.01ms	0	0~65535	3, 4, 5, 6, 7	Servo OFF	Immediately	

The speed command passes the 1-time delay filter and become smooth speed command. If set it too large, the reponse will be slow.

P3-08	speed feedback filter time						
-------	----------------------------	--	--	--	--	--	--

	Unit	Default	Range	Suitable mode	Modify	Effective
	0.01ms	0	0~65535	3, 4, 5, 6, 7	Servo OFF	Immediately

Smooth filter the speed feedback. If set it too large, the speed feedback will distort and affect the control result.

5-5-10. Speed command input dead voltage

P3-10	Speed command input dead voltage					
	Unit	Default	Range	Suitable mode	Modify	Effective
	0.01V	0	0~100	4	Servo OFF	Immediately

Note: if the input speed command voltage is in the range of this parameter, the input voltage is considered to be 0.

5-6. Speed control (internal speed)

Basic parameter		
Parameter	Name	Reference
P0-01	Control mode selection	5-6-1
P5-10	Servo ON signal /S-ON	5-2-1
P3-01	Internal speed 1	5-6-2
P3-02	Internal speed 2	
P3-03	Internal speed 3	
P5-17	/SPD-D internal speed direction selection	5-6-3
P5-18	/SPD-A internal speed selection	
P5-19	/SPD-B internal speed selection	

Other parameters			
Key word	Parameter	Name	Reference
Proportion action	P5-11	Proportion action command /P-CON	5-5-4
Zero clamp	P5-21	Zero clamp /ZCLAMP	5-5-5
	P5-01	Zero clamp speed	
Speed coincidence checking	P5-29	/V-CMP speed coincidence checking	5-5-6
	P5-03	speed coincidence checking signal width /V-CMP	
Torque limit	P4-02	forward torque limit	5-5-7
	P4-03	reverse torque limit	
	P1-07	T-REF distribution	
	P4-04	Forward external torque limit	
	P4-05	Reverse external torque limit	
	P5-15	Forward external torque limit /P-CL	
	P5-16	Reverse external torque limit /N-CL	
P5-32	Torque up to limit value output /CLT		
Soft start	P3-05	soft start acceleration time	5-5-8
	P3-06	soft start deceleration time	
Filter	P3-07	Speed command filter time	5-5-9
	P3-08	Speed feedback filter time	

5-6-1. Control mode selection

Parameter	Set value	Meaning	Modify	Effective
P0-01	3	Speed control: internal speed selection	Servo OFF	Immediately

Function: internal speed selection will set 3 motor speeds and select the speed by external signal. It is not need to configure external speed generator or pulse generator.

No need external speed or pulse generator

Run the motor at set speed

5-6-2. Internal speed setting

P3-01	Internal speed 1					
	Unit	Default	Range	Suitable mode	Modify	Effective
	1rpm	100	-5000 ~ +5000	3	Any	Immediately
P3-02	Internal speed 2					
	Unit	Default	Range	Suitable mode	Modify	Effective
	1rpm	200	-5000 ~ +5000	3	Any	Immediately
P3-03	Internal speed 3					
	Unit	Default	Range	Suitable mode	Modify	Effective
	1rpm	200	-5000 ~ +5000	3	Any	Immediately

5-6-3. Input signal setting

Switch the running speed by below input signal:

Parameter	Signal	Type	Default	Meaning	Suitable mode	Modify	Effective
P5-17	/SPD-D	Input	n.0000	Need to distribute	3, 5, 6	Any	Re-power on
P5-18	/SPD-A	Input	n.0000	Need to distribute	3, 5, 6	Any	Re-power on
P5-19	/SPD-B	Input	n.0000	Need to distribute	3, 5, 6	Any	Re-power on

1. /SPD-D, /SPD-A, /SPD-B can be distributed to input signal by parameter P5-17, P5-18, P5-19. Refer to chapter 5-12-1.
2. When the running mode is 5, 6, /SPD-D auto-switch to origin setting; /SPD-A auto-switch to forward finding reference origin; /SPD-B auto-switch to reverse finding reference origin.

(1) Function realization

Input signal			Direction	Running speed
/SPD-D	SPD-A	SPD-B		
0	0	0	Forward	Internal speed is zero
	0	1		P3-01: SPEED1
	1	1		P3-02: SPEED2
	1	0		P3-03: SPEED3
1	0	0	Reverse	Internal speed is zero
	0	1		P3-01: SPEED1
	1	1		P3-02: SPEED2

1	0	P3-03: SPEED3
Note: 1. SPEED1—SPEED2—SPEED3 switch as 01—11—10 but not 01—10—11. This can avoid the speed become zero at the space time of signal switching. 2. Please differ the signal state from terminal state.		

(2) Running example

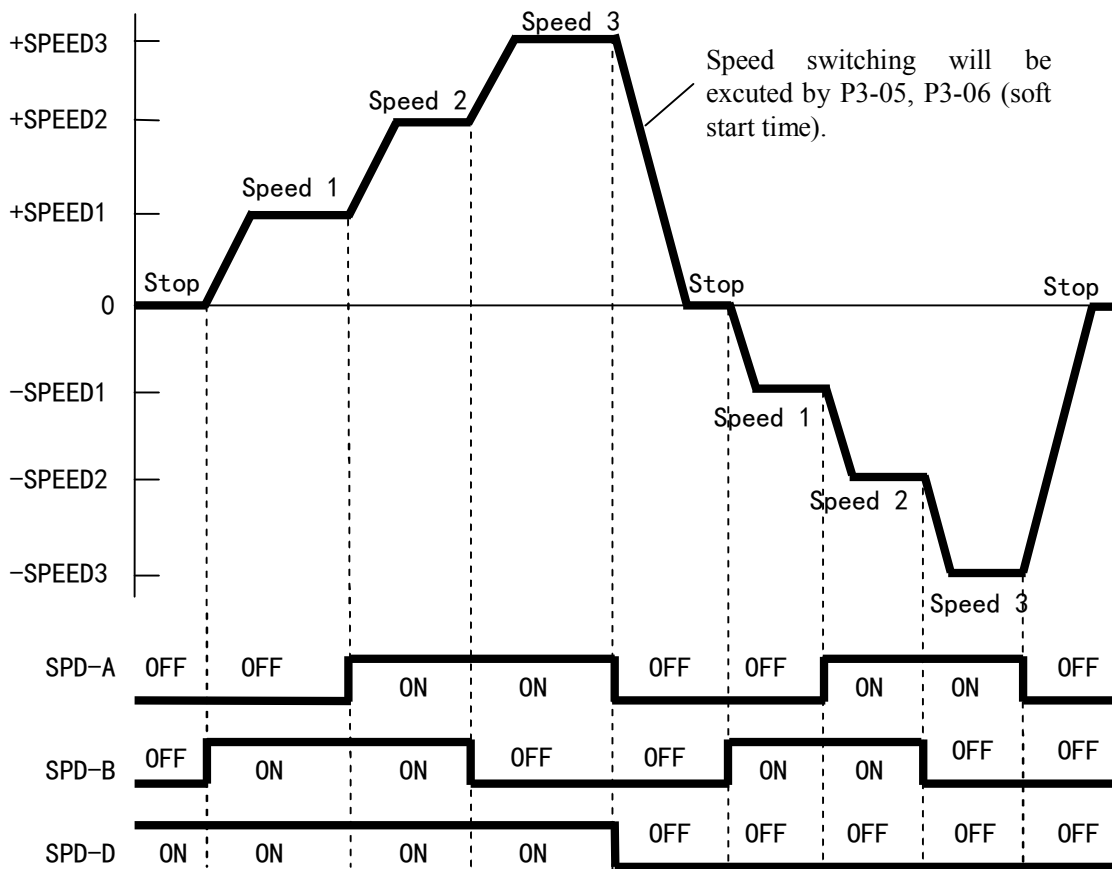

5-7. Speed control (pulse frequency command)

Basic parameter			
Parameter	Name		Reference
P0-01	Control mode selection		5-7-1
P5-10	Servo ON signal /S-ON		5-2-1
P2-00	Pulse command form		5-3-2
P2-06	Command pulse frequency at rated speed		5-7-3
P2-07	Speed command pulse filter time		5-7-4
Other parameters			
Key words	Parameter	Name	Reference
Proportion	P5-11	Proportion action command /P-CON	5-5-4
Zero clamp	P5-21	Zero clamp /ZCLAMP	5-5-5
	P5-01	Zero clamp speed	
Speed coincidence checking	P5-29	Speed coincidence checking /V-CMP	5-5-6
	P5-03	Coincidence speed checking signal width /V-CMP	
Torque limit	P4-02	Forward torque limit	5-5-7
	P4-03	Reverse torque limit	
	P1-07	T-REF distribution	
	P4-04	Forward external torque limit	

	P4-05	Reverse external torque limit	
	P5-15	Forward external torque limit /P-CL	
	P5-16	Reverse external torque limit /N-CL	
	P5-32	Torque up to limit value output /CLT	
Filter	P3-08	Speed feedback filter time	5-5-9

5-7-1. Control mode selection

Parameter	Set value	Meaning	Modify	Effective
P0-01	7	Speed control: pulse frequency speed command	Servo OFF	Immediately

Function: speed command is decided by external pulse frequency, but not related to pulse quantity. The wiring is the same as position command. Select CW, CCW mode or direction + pulse mode.

5-7-2. Pulse frequency command

Pulse frequency command is the same as external pulse command position control (mode 6), refer to chapter 5-3-2.

5-7-3. Command pulse frequency at rated speed

P2-06	command pulse frequency at rated speed					
	Unit	Default	Range	Suitable mode	Modify	Effective
	100Hz	5000	1~10000	7	Servo OFF	Immediately

Note: the unit is 100Hz.

Example: P2-06=1000, command pulse frequency at rated speed=100kHz;

P2-06=300, command pulse frequency at rated speed= 30kHz.

5-7-4. Speed command pulse filter time

P2-07	speed command pulse filter time					
	Unit	Default	Range	Suitable mode	Modify	Effective
	0.1ms	20	0~1000	7	Servo OFF	Immediately

When the command pulse frequency is low, setting a suitable value for this parameter can decrease the speed fluctuation.

5-8. Torque control (analog voltage command)

❖ Only DS2-2□P□-A and DS2-2□P□-B support this mode.

Parameter		
Parameter	Name	Reference
P0-01	Control mode selection	5-8-1
P4-00	The analog value of rated torque	5-8-2

P5-10	Servo ON signal /S-ON	5-2-1
-------	-----------------------	-------

Other parameters			
Key words	Parameter	Name	Reference
Zero drift adjustment	F1-04	Torque command offset auto-adjustment	5-8-3
Filter	P4-01	Torque command filter time	5-8-4
Speed limit	P4-07	internal speed limit in torque control mode	5-8-5
	P3-09	Max speed control (MAX speed)	
	P0-08	V-REF function distribution	
	P5-33	Speed up to limit value output	
Dead area	P4-10	Torque command input dead area voltage	5-8-6

5-8-1. Control mode selection

Parameter	Set	Function	Modify	Effective
P0-01	2	Torque control: analog voltage command	Servo OFF	Immediately

Function: Control the torque by the analog voltage signal input from T-REF terminal.

5-8-2. The analog value of rated torque

P4-00	The analog value of rated torque					
	Unit	Default	Range	Suitable mode	Modify	Effective
	0.01V/rated torque	1000	150~3000	2	Servo OFF	Immediately

Function: set the speed command voltage (T-REF) to run the servo motor at rated speed
Example: P4-00=500, motor run at rated torque when analog input voltage is 5.00V
P4-00=800, motor run at rated torque when analog input voltage is 8.00V

Refer to chapter 3-2-4 for analog torque command input.

5-8-3. Torque command offset autoadjustment (F1-04)

The motor will run at microspeed even the command voltage is 0V in analog voltage torque mode. This situation will happen when host controller or the command voltage of external circuit has micro-offset (mV). Use the operate panel to auto-adjust the offset. Refer to chapter 4-4-2.

5-8-4. Torque command filter time

P4-01	torque command filter time					
	Unit	Default	Range	Suitable mode	Modify	Effective
	0.01ms	0	0~65535	1, 3, 4, 5, 6, 7	Servo stop	Immediately

1-time delay filter will smooth the torque command. If set the value too large, the reponse will be decreased.

5-8-5. Torque limit

5-8-5-1. Internal speed limit

Limit the speed of torque control by setting below parameters:

P4-07	internal speed limit in torque control mode					
	Unit	Default	Range	Suitable mode	Modify	Effective
	1rpm	2000	0~5000	1, 2	Servo OFF	Immediately
Note: the actual speed is max speed even this parameter speed is larger than the max speed.						

P3-09	max speed limit					
	Unit	Default	Range	Suitable mode	Modify	Effective
	1rpm	1500:2000 2500:3000 3000:4000	0~5000	All modes	Servo OFF	Immediately
<p>Note: 1. P3-09 is effective in all modes.</p> <p>2. Default setting is different for each type. For example: max speed is 2000 for rated speed 1500 motor, max speed is 4000 for rated speed 3000 motor.</p> <p>3. This parameter is related to E-008 and E-010. If motor speed is larger than max speed+200, servo will show E-008 over-speed. If the pulse frequency converts to motor speed, the speed is larger than max speed; but the actual motor speed is max speed. Then the pulse offset will accumulate, servo will show E-010 alarm.</p>						

5-8-5-2. External speed limit

Limit the speed output of torque control mode by the analog voltage command input from V-REF terminal.

Parameter	Function	Set value	Meaning	Modify	Effective
P0-08	V-REF function distribution	1	Make V-REF as external speed limit input	Servo stop	Immediately
<p>1. The analog voltage has no polarity. The absolute value of the voltage is suitable for forward and reverse direction.</p> <p>2. The parameter value is related to voltage command and P3-00 when it is used as speed limit value. For example: P3-00=500 (voltage of rated speed is 5.0V), T-REF voltage command is 1.0V, the speed limit is 20% of rated speed.</p> <p>3. P0-08=1, the actual limit value is the smaller value among V-REF speed limit input and P4-07.</p>					

5-8-5-3. Speed up to limit value output

Parameter	Signal	Type	Default	Meaning	Suitable mode	Modify	Effective
P5-33	/VLT	Output	n.0000	Need to distribute	1, 2	Any	Re-power on
<p>1 if the motor speed is up to speed limit value in torque control mode, it will output /VLT signal.</p> <p>2 /VLT can be distributed to output terminal via parameter P5-33. Refer to chapter 5-12-3.</p>							

5-8-6. Torque command input dead area voltage

P4-10	Torque command input dead area voltage					
	Unit	Default	Range	Suitable mode	Modify	Effective
	0.01V	0	0~100	2	Servo OFF	Immediately
Note: if the input torque command voltage is smaller than this parameter, the torque command is 0.						

5-9. Torque control (internal setting)

Basic parameter		
Parameter	Name	Reference
P0-01	Control mode selection	5-9-1
P5-10	Servo ON signal /S-ON	5-2-1
P4-09	Internal torque command	5-9-2

Other parameters			
Key words	Parameter	Name	Reference
Filter	P4-01	Torque command filter time	5-8-4
Speed limit	P4-07	Internal speed limit of torque control	5-8-5
	P3-09	Max speed limit (max speed)	
	P0-08	V-REF function distribution	
	P5-33	Speed up to limit value output	

5-9-1. Control mode selection

Parameter	Set value	Function	Modify	Effective
P0-01	1	Torque control: internal setting	Servo OFF	Immediately

Function: Control the torque by internal torque command.

5-9-2. Internal torque command

P4-09	Internal torque command					
	Unit	Default	Range	Suitable mode	Modify	Effective
	1% rated torque	0	-300~+300	1	Servo OFF	Immediately

The unit of this parameter is 1% of the rated torque.
 For example: P4-09=50, motor forward run with 50% of the rated torque;
 P4-09=-20, motor reverse run with 20% of the rated torque.

5-10. Switch the control mode

Servo can switch between submode 1 and 2 by external input signal.

(1) Switch signal

Parameter	Signal	Type	Default	Meaning	Suitable mode	Modify	Effective
P5-20	/C-SEL	Input	n.0000	Need to distribute	All modes	Running	Re-power on

Note: /C-SEL can be distributed to input terminal via parameter P5-20, refer to chapter 5-12-1.

(2) Function realization

Signal	State	Control mode
/C-SEL	0	P0-01: submode 1
	1	P0-02: submode 2

5-11. Other output signals

5-11-1. /ALM and /ALM-RST

■ Servo alarm output /ALM

Parameter	Signal	Type	Default	Meaning	Effective
P5-37	/ALM	Output	n.0002	Output always open signal from SO2	Re-power on
1. The servo unit is force OFF when alarming, the motor will move with external force (including gravity). If it is need to hold the motor, please use power-loss brake (contracting brake) and /BK signal. Refer to chapter 5-2-5. 2. /ALM can be distributed to output terminal via parameter P5-37, refer to chapter 5-12-3.					

■ Alarm reset /ALM-RST

Parameter	Signal	Type	Default	Meaning	Effective
P5-14	/ALM-RST	Input	n.0002	Input always open signal from SI2	Re-power on
1. Find the alarm reason and fix it, then clear the alarm via this signal. 2. /ALM-RST can be distributed to input terminal via this parameter. As the alarm signal is related to the safe running of servo, /ALM-RST signal cannot be set to always effective. (n.0010); 3. The alarm related to encoder such as E-013, E-014 cannot be reset via /ALM-RST. 4. /ALM-RST can be distributed to input terminal via parameter P5-14, refer to chapter 5-12-1.					

5-11-2. /WARN

Parameter	Signal	Type	Default	Meaning	Effective
P5-35	/WARN	Output	n.0000	Need to distribute	Re-power on
When the warning happens, servo will not be force OFF but output the warning.					

5-11-3. Rotation checking (/TGON)

(1) Signal setting

Parameter	Signal	Type	Default	Meaning	Effective
P5-30	/TGON	Output	n.0000	Need to distribute	Re-power on
1. The servo will be considered in the rotation when the servo motor speed is higher than P5-02. 2. The application function related to /TGON is /BK power-off brake. 3. /TGON can be distributed to output terminal via parameter P5-30, refer to chapter 5-12-3.					

(2) Parameter setting

P5-02	Internal torque command setting					
	Unit	Default	Range	Suitable mode	Modify	Effective
	1rpm	20	1~1000	All modes	Servo OFF	Immediately
Set the range of rotation checking output. If servo motor speed is up to P5-02, the servo motor is considered to be running and output rotation checking signal (/TGON).						

5-11-4. Servo ready (/S-RDY)

Parameter	Signal	Type	Default	Meaning	Effective
P5-31	/S-RDY	Output	n.0000	Need to distribute	Re-power on
1. The servo is ready to receive S-ON signal, servo motor can power on. S-RDY will output when the main circuit is ON and no alarm. 2. /S-RDY signal can be distributed to output terminal via parameter P5-31. Refer to chapter 5-12-3.					

5-11-5. Encoder Z phase output (/Z)

DS2 series servo supports encoder (Z phase) signal output.

Parameter	Signal	Type	Default	Meaning	Effective
P5-38	/Z	Output	n.0000	Need to distribute	Re-power on

1. /Z can be distributed to output terminal via parameter P5-38, refer to chapter 5-12-3.
 2. Z phase signal is single pulse output mode. Pulse width is about 1.5ms and not related to motor rotation speed.

5-11-6. AB phase feedback signal of encoder

DS2-2□P□-A supports open collector output AB phase feedback signal.

Please see the following wiring diagram of DS2-21P5-A and Xinje PLC XC3-32RT-E.

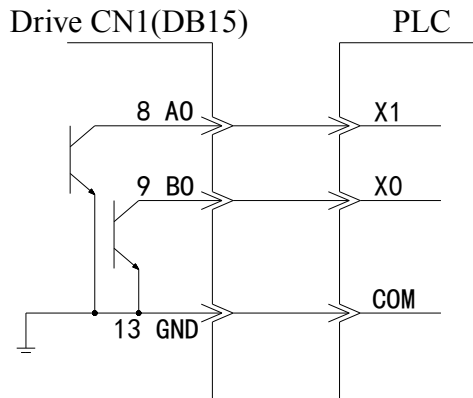

AB phase feedback signal doesn't have parameters to set; it is motor encoder 1:1 output.

Note: DS2-2□P□-B only supports AB phase feedback signal in differential signal mode.

5-12. I/O signal distribution

5-12-1. Input signal distribution

Parameter	Set value	Meaning	Terminal voltage	Terminal state	Signal state
n.00 y x 00: no meaning y: 0 always open 1 always close x: input terminal no.	n.0000	Not distribute to terminal input	-	-	0
	n.000x	Input always open signal from Six	H	Disconnect to 0V	0
			L	Connect to 0V	1

	n.0010	Set the signal to be always valid	-	-	1
	n.001x	Input always close signal from SIx	H	Disconnect to 0V	1
			L	Connect to 0V	0

Note: if the distributed terminal has other signal, set the signal to other terminal or set to unused.

The setting range of input terminal for each type:

Input terminal parameter	Servo type	Range
P5-10~P5-24	DS2-20P2 DS2-20P4 DS2-20P7	n.0000~n.0002 n.0010~n.0012
	DS2-21P5	n.0000~n.0004 n.0010~n.0014
	DS2-2□P□-A DS2-2□P□-B	n.0000~n.0006 n.0010~n.0016

Because the input terminal quantity is different for each type, the setting range is different.

Example: take the input signal /CLR (P5-24) of DS2-20P7 as an example to explain the terminal distribution.

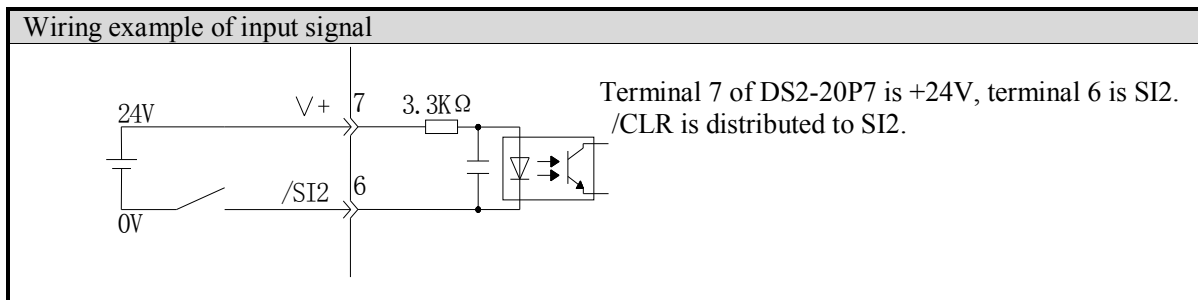

Parameter	Set value	Terminal state	Signal state	Meaning
P5-24	n.0002	Disconnect to 0V	0	Clear the pulse offset at the moment of SI2 and 0V connected
		Connect to 0V	1	
	n.0012	Disconnect to 0V	1	Clear the pulse offset at the moment of SI2 and 0V disconnected
		Connect to 0V	0	

Note: the default input of SI2 is /ALM-RST, make sure to distribute P5-14(/ALM-RST) to other terminal or set to unused.

5-12-2. Default setting of input terminal

	SI1	SI2	SI3	SI4	SI5	SI6
DS2-20P2 DS2-20P4 DS2-20P7	/S-ON	/ALM-RST	-	-	-	-
DS2-21P5	/S-ON	/ALM-RST	/P-OT	/N-OT	-	-
DS2-2□P□-A DS2-2□P□-B	/S-ON	/ALM-RST	/P-OT	/N-OT	/SPD-A	/SPD-B

5-12-3. Output terminal distribution

Parameter meaning	Set value	Meaning	Signal state	Terminal state
n.00 y x 00: pointless y: 0 always open 1 always close x: output terminal no.	n.0000	Not distribute to terminal input	-	-
	n.000x	Output always open signal from S0x	0	Disconnect to COM
			1	Connect to COM
	n.0010	Set the signal to be always valid	-	-
n.001x	output always close signal from S0x	0	Connect to COM	
		1	Disconnect to COM	

Note: If the distributed terminal has other signal, please set the signal to other terminal or set to unused.

Setting range of input terminal for each type:

Input terminal parameter	Servo type	Range
P5-28~P5-38	DS2-20P2 DS2-20P4 DS2-20P7	n.0000~n.0002 n.0010~n.0012
	DS2-21P5 DS2-2□P□-A DS2-2□P□-B	n.0000~n.0003 n.0010~n.0013

Example: take /BK signal of DS2-21P5-A as an example to explain output terminal distribution.

Output terminal wiring example

S03 output of DS2-21P5-A is at CN1 (DB15). Pin no. of S03 is CN1-6, pin no. of COM is CN1-7.

Parameter	Set value	/S-ON	/BK	Terminal state	Meaning
P5-34	n.0013	1	0	S03 connect to COM	Brake power on and loosen, motor can work
		0	1	S03 disconnect to COM	Brake power off and tighten, motor cannot work

Note: the default output of S03 is /S-RDY. Set the P5-31 (/S-RDY) to other terminal or unused in order to avoid terminal signal conflict.

5-12-4. Default setting of output terminal

	SO1	SO2	SO3
DS2-20P2 DS2-20P4 DS2-20P7	/COIN	/ALM	-
DS2-21P5 DS2-2□P□-A DS2-2□P□-B	/COIN	/ALM	/S-RDY

6 Servo gain adjustment

This chapter will introduce some skills about servo gain adjustment.

6-1. Servo gain setting

6-1-1. Gain setting of speed loop

Gain parameters about speed loop:

P1-00	Speed loop gain (Kp)					
	Unit	Default	Range	Suitable mode	Modify	Effective
	1Hz	100	1~5000	3, 4, 5, 6, 7	Any	Immediately
P1-01	Speed loop integral time constant (Ki)					
	Unit	Default	Range	Suitable mode	Modify	Effective
	0.1ms	400	1~5000	3, 4, 5, 6, 7	Any	Immediately

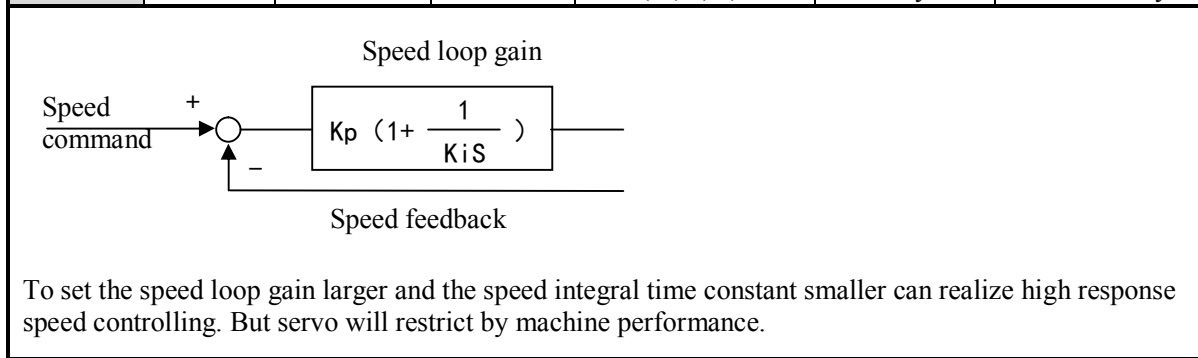

6-1-2. Gain setting of position loop

6-1-2-1. Position loop proportion gain

Gain parameter about position loop:

P1-02	Position loop gain (Kp)					
	Unit	Default	Range	Suitable mode	Modify	Effective
	1/s	100	1~2000	5, 6	Any	Immediately

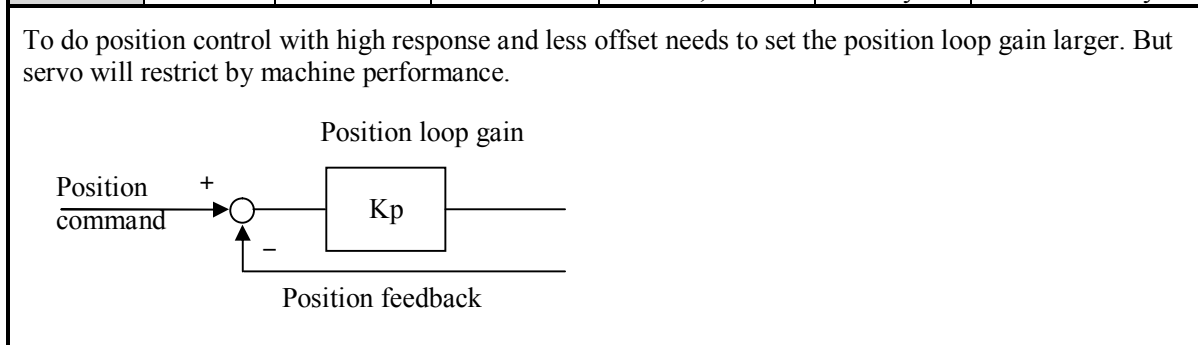

In position control mode, the servo will alarm when the offset pulse over the limit value. The value is offset pulse limit parameter:

P5-05	Offset pulse limit					
	Unit	Default	Range	Suitable mode	Modify	Effective
	256*command pulse	1000	0~65535	5, 6	Servo OFF	Immediately

The offset pulse will not be checked when offset pulse limit value is 0.

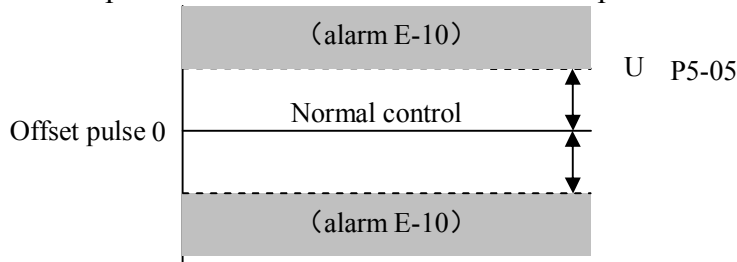

6-1-2-2. Position loop feedforward gain

P1-09	position loop feedforward gain (Kp)					
	Unit	Default	Range	Suitable mode	Modify	Effective
	1%	0	1~100	5, 6	Any	Immediately
The unit is 1% of offset pulse. To increase the feedforward gain of position loop in the case that requires quick response of position loop. If set it too large, the speed loop will overshoot.						
P1-10	feedforward filter time					
	Unit	Default	Range	Suitable mode	Modify	Effective
	0.01ms	0	0~65535	5, 6	Any	Immediately

6-1-3. The experience of parameter adjustment

First, it is important to know the mechanical structure. Common synchronous machine with driving has less rigidity, decrease the servo rigidity to match it. Large inertia mechanical system has long response time, it needs to decrease the servo rigidity and set more acceleration/deceleration time for speed command. For the mechanical system with small load inertia and strong rigidity such as coupling, it needs to increase the servo rigidity to improve the positioning efficiency.

Servo parameter adjustment method in position mode for typical mechanical system:

(1) Mechanical system: synchronous with coupling, large load inertia.

Servo system: decrease the rigidity, increase speed loop integral time (P1-01), decrease the position loop gain (P1-02). If the response is not enough after adjusting, increase the speed loop gain (P1-00).

Typical setting: P1-00=200, P1-01=2000, P1-02=50.

(2) Mechanical system: synchronous with coupling, small load inertia and load torque.

Servo system: follow the default parameter.

(3) Mechanical system: rigidity coupling, large load inertia.

Servo system: same to (1).

Typical setting: P1-00=100, P1-01=1000, P1-02=80.

(4) Mechanical system: rigidity coupling, small load inertia, strong rigidity.

Servo system: P1-00=100, P1-01=300, P1-02=150. If it cannot meet the requirements, please increase the position loop feedforward, for example set P1-09 to 20.

Note: above typical settings only show the direction to adjust the parameters. The settings cannot be suitable for all the conditions.

6-1-4. Proportion action command (P-CON)

Input signal /P-CON is switch for P/PI control of speed loop.

P control means proportion control; this mode is called proportion action command.

Input terminal selection of /P-CON:

Parameter	Signal	Type	Default	State	Meaning	Modify	Effective
P5-11	/P-CON	Input	n.0000	1	Run in P control mode	Any	Re-power on
				0	Run in PI control mode		
/P-CON can be distributed to input terminal via parameter P5-11. Refer to chapter 5-12-1.							

This command is suitable for the following cases:

- (1) When the host device sends speed command to the servo and runs with it at the same time, it only selects P mode running under special conditions. The overrange can be deleted by this method and the adjustment time can be shortened.
- (2) When there is command offset in speed controlling, servo will not stop and run at low speed even getting zero speed command in PI control mode. If select P control mode, the servo will stop.

6-1-5. Gain switch (G-SEL)

This function can switch the gain online.

For example, set different first and second gain by the external signal when the motor is running or stop.

Select the input terminal for /G-SEL signal:

Parameter	Signal	Type	Default	Meaning	Suitable mode	Modify	Effective
P5-23	/G-SEL	Input	n.0000	Need to distribute	3, 4, 5, 6, 7	Any	Re-power on
/G-SEL can be distributed to input terminal via parameter P5-23. Refer to chapter 5-12-1.							

Function realization:

Input signal	Signal state	Gain group
/G-SEL	0	P1-00, P1-01, P1-02
	1	P1-04, P1-05, P1-06
Note: the 0, 1 is signal state but not terminal state.		

7 Specification and dimension

This chapter will introduce the specification and dimension of MS series servo motor and DS2 series servo drive.

7-1. Servo motor

7-1-1. Servo motor specification

Please refer to this chapter when selecting the servo drive.

Voltage level		220V						
Motor type MS-		60ST-		80ST-	90ST-	110ST-		
		M00630	M01330	M02430	M02430	M04030	M05030	
		□□-20P2	□□-20P4	□□-20P7		□□-21P2	□□-21P5	
Motor code		0003	0004	0011	0021	0031	0032	
Rated power (KW)		0.2	0.4	0.75	0.75	1.5	1.5	
Rated current (A)		1.5	2.5	3.0	3.0	5.0	6.0	
Rated speed (rpm)		3000	3000	3000	3000	3000	3000	
Max speed (rpm)		4000	4000	4000	4000	3500	3500	
Rated torque (N·m)		0.637	1.27	2.39	2.4	4	5	
Peak torque (N·m)		1.91	3.8	7.1	7.1	12	15	
Back EMF const (V/krpm)		28	28	48	51	54	62	
Torque coefficient (N·m/A)		0.42	0.5	0.8	0.8	0.8	0.83	
Rotor inertia (Kg·m ²)		0.17×10 ⁻⁴	0.438×10 ⁻⁴	0.24×10 ⁻³	0.24×10 ⁻³	0.54×10 ⁻³	0.63×10 ⁻³	
Winding resistor (Ω)		11.6	3.49	2.88	3.2	1.09	1.03	
Winding inductance (mH)		22	8.47	6.4	7.0	3.3	3.43	
Electrical time constant (ms)		1.9	2.4	2.22	2.2	3.0	3.33	
Weight (Kg)		1.11	1.78	2.86	3.4	5.5	6.7	
Encoder ppr (PPR)		2500						
Pole pairs		4						
Motor insulation level		Class B (130°C)						
Protection level		IP64		IP65				
Ambient	Temperature	-20°C ~ +50°C						
	Humidity	Relative humidity <90% (no condensation)						

Voltage level		220			
Motor type MS-		130ST-			180ST-
		M06025	M10015	M15015	M19015
		□□-21P5	□□-21P5	□□-22P3	□□-23P0
Motor code		0042	0044	0046	0052
Rated power (KW)		1.5	1.5	2.3	3.0
Rated current (A)		6.0	6.0	9.5	12.0
Rated speed (rpm)		2500	1500	1500	1500

Max speed (rpm)	3000	2000	2000	2000
Rated torque (N·m)	6	10	15	19
Peak torque (N·m)	18	25	30	47
Back EMF constat (V/krpm)	65	103	114	97
Torque coefficient (N·m/A)	1.0	1.67	1.58	1.58
Rotor inertia (Kg·m ²)	1.26×10 ⁻³	1.94×10 ⁻³	2.77×10 ⁻³	3.8×10 ⁻³
Winding resistor (Ω)	1.01	1.34	1.1	0.4
Winding inductance (mH)	2.94	5.07	4.45	2.42
Electrical time constant (ms)	3.8	3.78	4.05	6
Weight (Kg)	10	11.5	14.4	20.5
Encoder ppr (PPR)	2500			
Pole pairs	4			
Motor insulation level	Class B (130°C)			
Protection level	IP65			
Ambient	Temperature	-20°C ~ +50°C		
	Humidity	Relative humidity <90% (no condensation)		

■ 60, 80 and 90 series servomotors winding connector

Motor Winding connector	Winding Name	U	V	W	PE
	Connector	1	3	2	4

■ 60, 80 and 90 series servo motor encoder connector

Signal	5V	0V	B+	Z-	U+	Z+	U-	A+	V+	W+	V-	A-	B-	W-	PE
Connector	2	3	4	5	6	7	8	9	10	11	12	13	14	15	1

■ 110, 130, 180 series servo motor winding connector

Motor Winding connector	Winding Name	U	V	W	PE
	Connector	2	3	4	1

■ 110, 130, 180 series servo motor encoder connector

Signal	5V	0V	A+	B+	Z+	A-	B-	Z-	U+	V+	W+	U-	V-	W-	PE
Connector	2	3	4	5	6	7	8	9	10	11	12	13	14	15	1

7-1-2. Torque-Speed Feature

A: continuous use area

B: repeated use area

MS-60ST-M01330□□-20P4

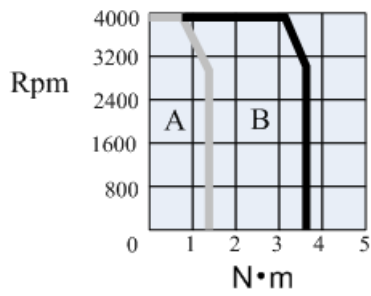

MS-80ST-M02430□□-20P7

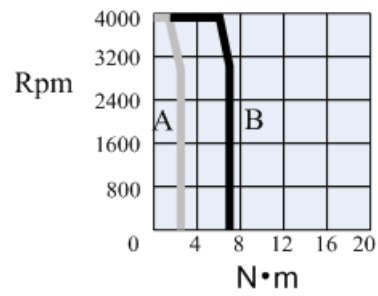

MS-90ST-M02430□□-20P7

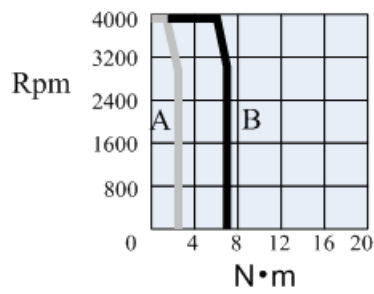

MS-110ST-M04030□□-21P2

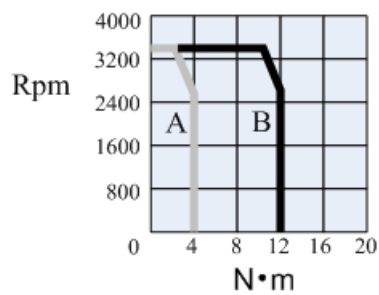

MS-110ST-M05030□□-21P5

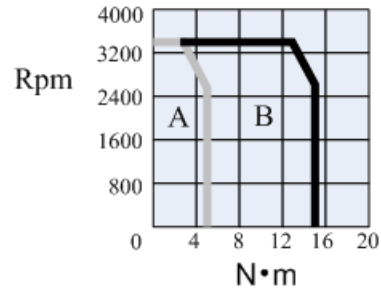

MS-130ST-M06025□□-21P5

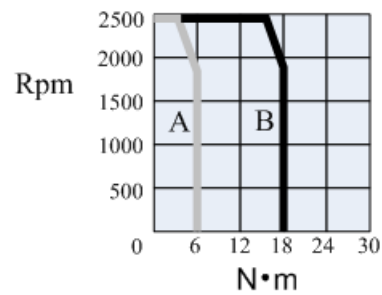

MS-130ST-M10015□□-21P5

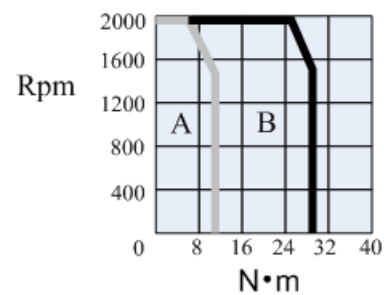

7-1-3. Servo motor dimensions

■ Dimensions of 60 series servo motors (unit: mm)

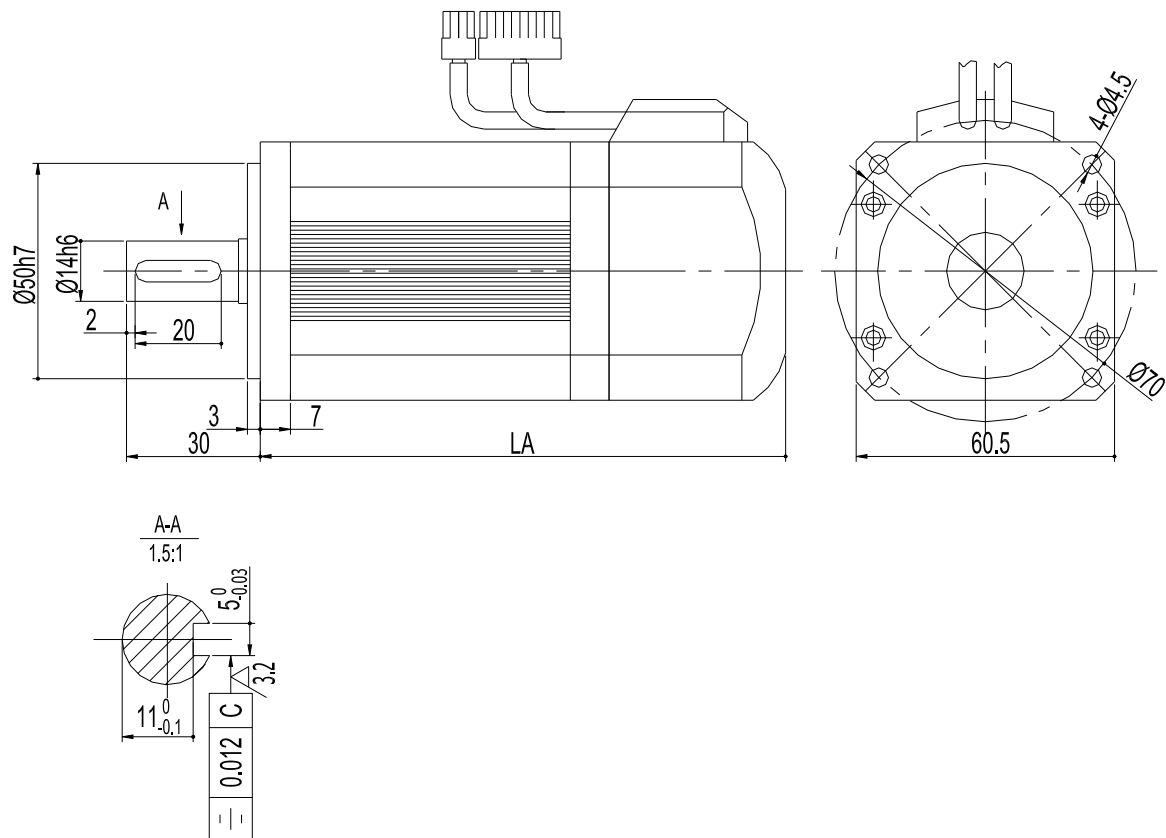

Type	LA	
	Normal	Band-type brake
MS-60ST-M00630□□-20P2	102	145
MS-60ST-M01330□□-20P4	146	189

■ Dimensions of 80 series servo motors (unit: mm)

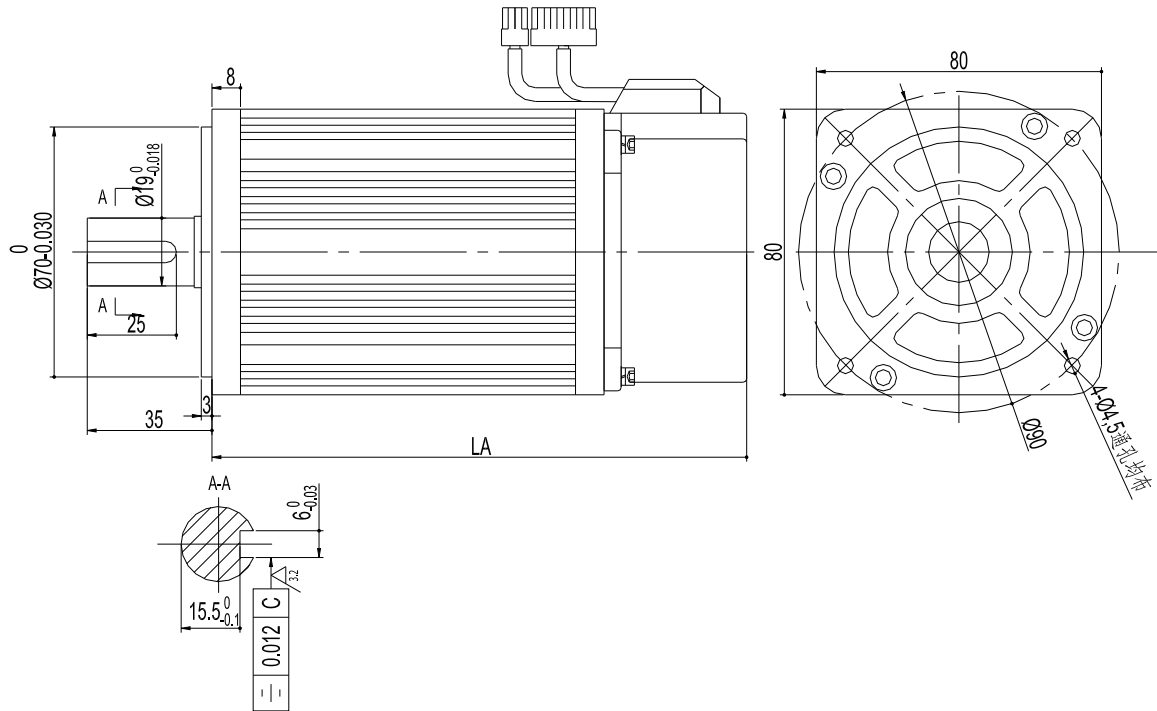

Type	LA	
	Normal	Band-type brake
MS-80ST-M02430□□-20P7	150	191

■ Dimensions of 90 series servo motors (unit: mm)

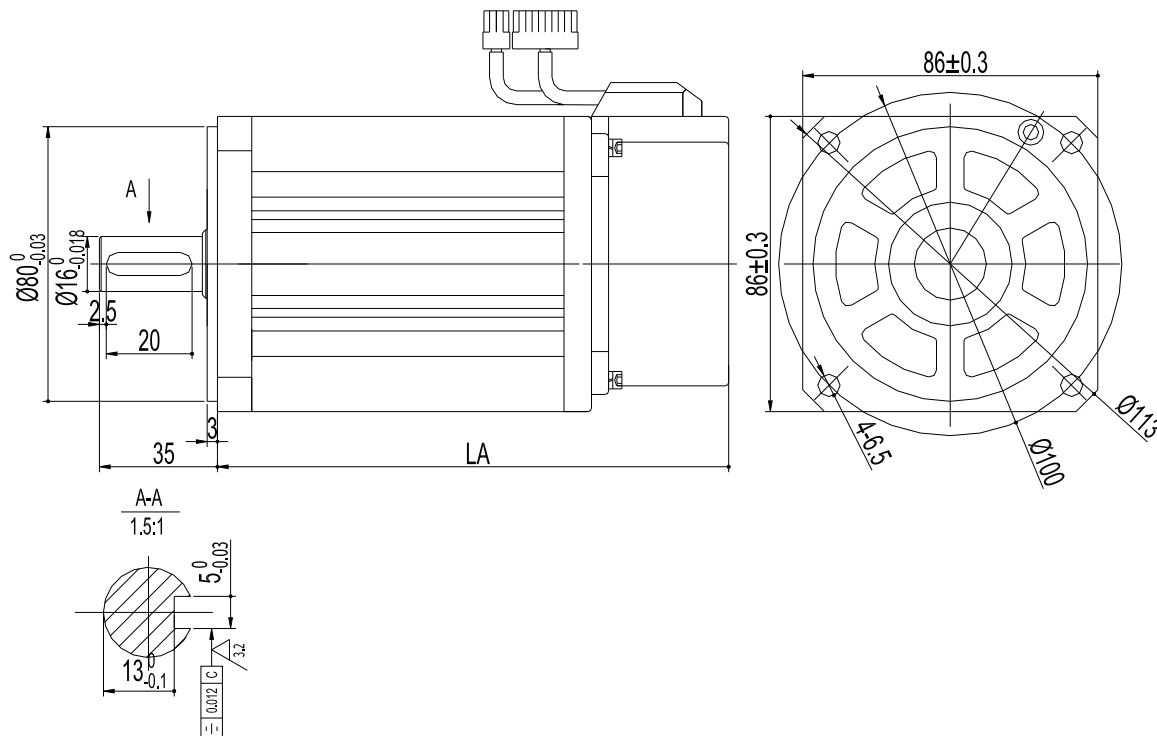

Type	LA	
	Normal	Band-type brake
MS-90ST-M02430□□-20P7	149	194

■ Dimensions of 110 series servo motors (unit: mm)

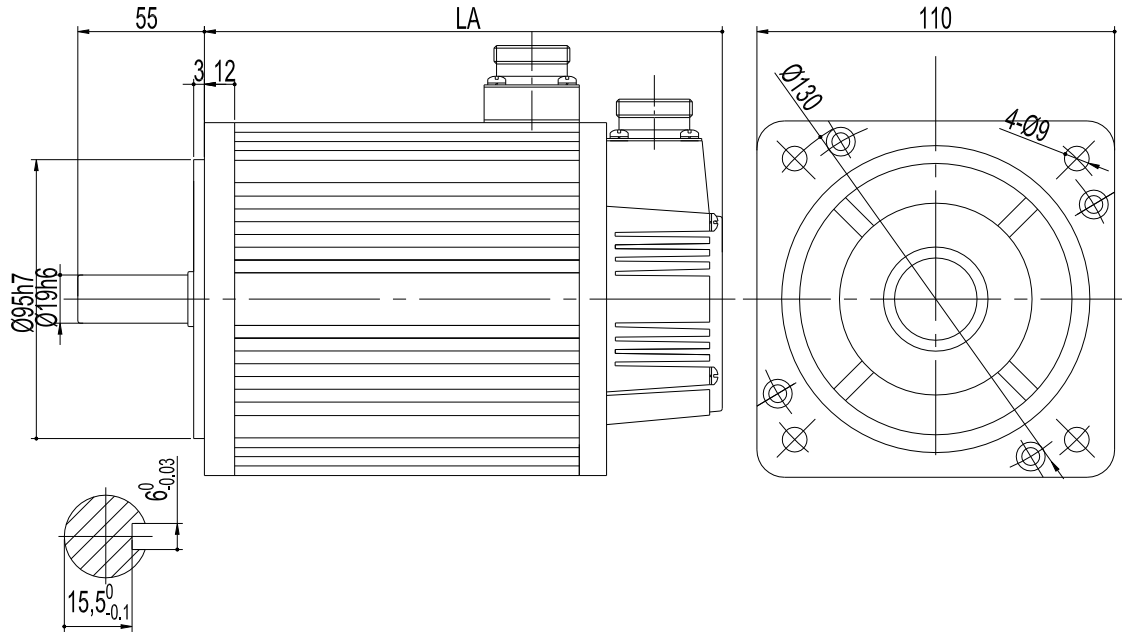

Type	LA	
	Normal	Band-type brake
MS-110ST-M04030□□-21P2	189	263
MS-110ST-M05030□□-21P5	204	278

■ Dimensions of 130 series servo motors (unit: mm)

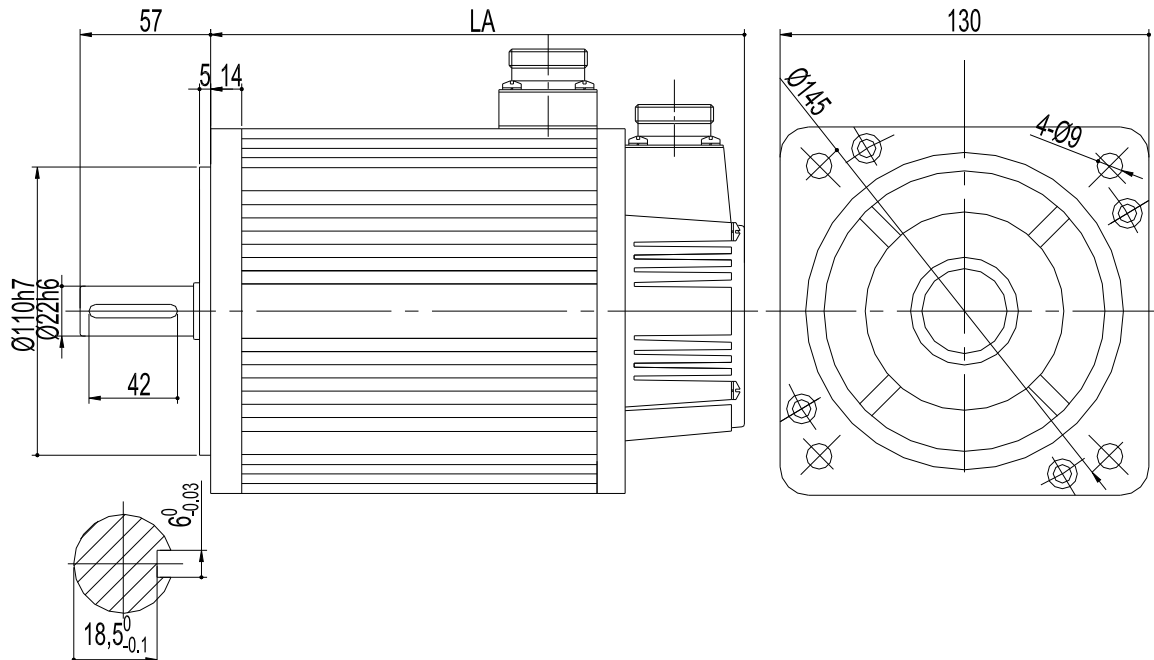

Type	LA	
	Normal	Band-type brake
MS-130ST-M06025□□-21P5	179	236
MS-130ST-M10015□□-21P5	213	270
MS-130ST-M07725□□-22P0	192	249
MS-130ST-M15015□□-22P3	241	298

■ Dimensions of 180 series servo motors (unit: mm)

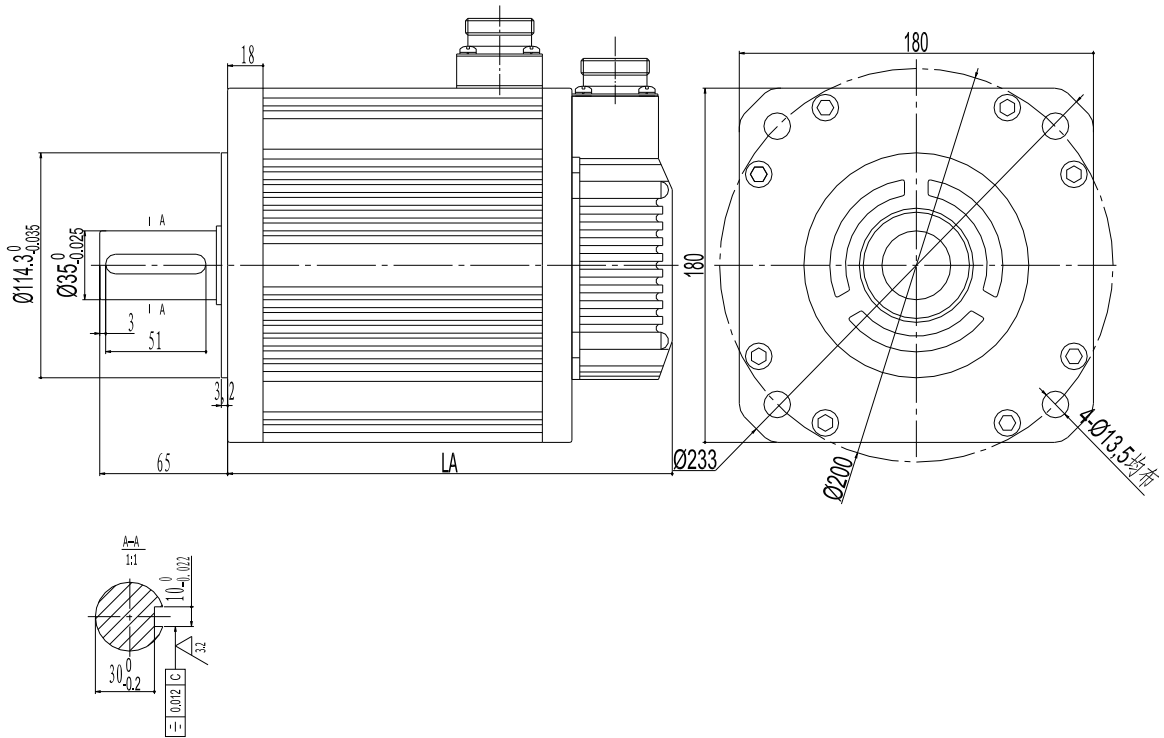

Type	LA	
	Normal	Band-type brake
MS-180ST-M19015□□-23P0	232	289

7-2. Servo drivers

This section introduces the specification and dimension of servo drive.

7-2-1. General specification

Servo unit	DS2 series 220V servo drive	
Encoder	Incremental encoder (2500 ppr)	
Input power	DS2-2□P□: single phase AC200~240V, 50/60Hz DS2-2□P□-A: 3-phase AC200~240V, 50/60Hz DS2-2□P□-B: 3-phase AC200~240V, 50/60Hz	
Control mode	3-phase full-wave rectifier control IPM PWM sine-wave current dirve	
Using	Temperature	0 ~ +50 °C / -20 ~ +85 °C
	Humidity	Below 90% RH (no condensation)
	Vibration /impact resistance	4.9m/s ² / 19.6m/s ²
Structure	Base installation	

7-2-2. Performance specification

Servo drive type		DS2-20P2	DS2-20P4 DS2-20P7	DS2-21P5	DS2-2□P□-A	DS2-2□P□-B	
Speed torque control mode	Performance	Speed control range		1: 4000 (the lower limit of speed control range, not stop at rated load torque)			
		Speed change rate	Load change rate	0~100% load: below ±0.01% (rated speed)			
			Voltage change rate	Rated voltage ±10% : 0% (rated speed)			
			Temperature change rate	20±25°C: below ±0.1% (rated speed)			
		Frequency feature		250Hz (JL≤JM)			
		Soft start time		0~65535ms (set acceleration, deceleration individually)			
Input signal		RS485					
Position control mode	Performance	Feedforward compensation		0~100% (resolution is 1%)			
		Positioning finished width		0~250 command unit (resolution is 1 command unit)			
	Input signal	Command pulse	Input pulse type	Sign+pulse, CW, CCW mode			
			Input pulse state	Collector (+24V), DS2-2□P□-A and DS2-2□P□-B support differential signal			
			Input pulse frequency	Open collector input: 200kbps Differential input: 500kbps			
Control signal		Clear signal (/CLR)					
I/O signal	Position output		DS2-2□P□-A: open collector output DS2-2□P□-B: differential output (other types don't support this function)				
	Input signal	External input	2	2	4	6	6
		Changeable signal distribution	/S-ON, /P-CON, /P-OT, /N-OT, /ALM-RST, /PCL, /NCL, /SPD-D, /SPD-A, /SPD-B, /C-SEL, /ZCLAMP, /CLR, /G-SEL, /CHGSTP				
	Output signal	External output	2	2	3	3	3
Changeable signal distribution		/COIN, /V-CMP, /TGON, /S-RDY, /CLT, /VLT, /BK, /WARN, /NEAR, /ALM, /Z					
Built-in function	Dynamic brake (DB)		No				
	Regeneration		Built-in regeneration unit, external regenerative resistor				
	Over range (OT) protection		For P-OT, N-OT action, deceleration stop or inertia stop				
	Electronic gear		0.01≤B/A≤100				
	Protection		Program error, parameter error, overvoltage, undervoltage, regeneration error, overtemperature, overcurrent, overspeed, analog input error, position offset overflow, output shorting, current error, encoder cut, encoder error, overload, power off when running, write parameter error...				
	LED display		Charge, power supply, 7-segment LED ×5 (built-in digital operate)				
	communication	COM1	Connector	RS232, connect to PC			
			Serial parameter	Baud rate 19200; data bit 8; stop bit 1; communication protocol: ModbusRTU slave; Modbus station No.1			
			Function	Debug online			
		COM2	Connector	RS485, connect to PLC, HMI, PC and other devices			
Serial parameter			Serial parameter can be set; communication protocol: ModbusRTU slave; Modbus station No. can be set				
Function			State display, user constant setting, monitor display, alarm display, alarm display, special control, online debug				

7-2-3. Servo driver dimensions

- DS2-20P2, DS2-20P4, DS2-20P7 (unit:mm)

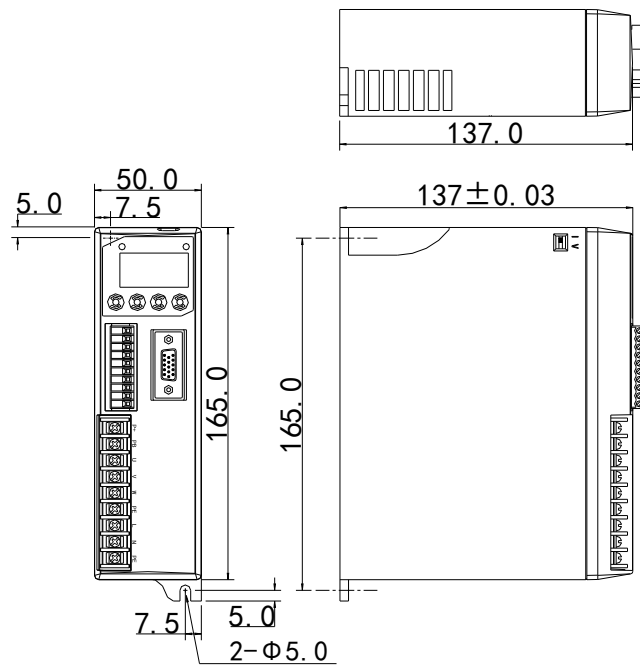

- DS2-21P5 (unit:mm)

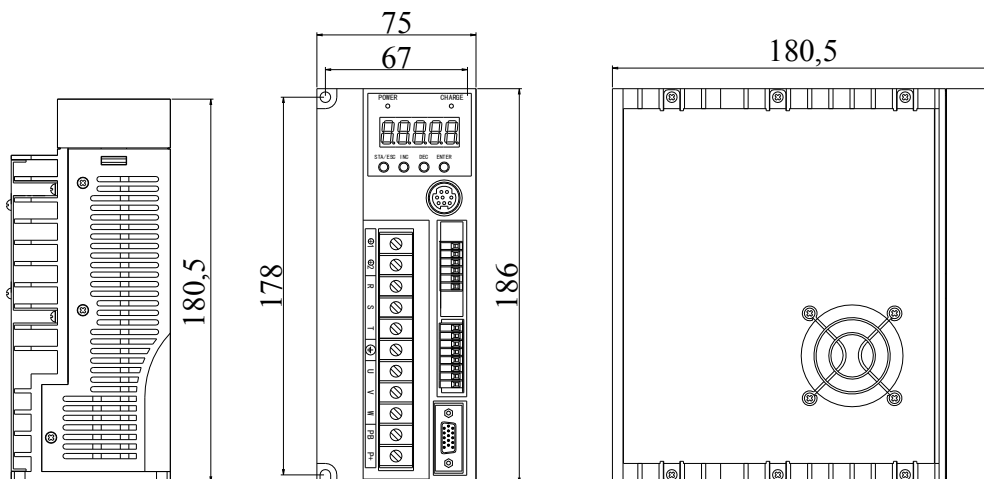

■ DS2-2□P□-A, DS2-2□P□-B (unit:mm)

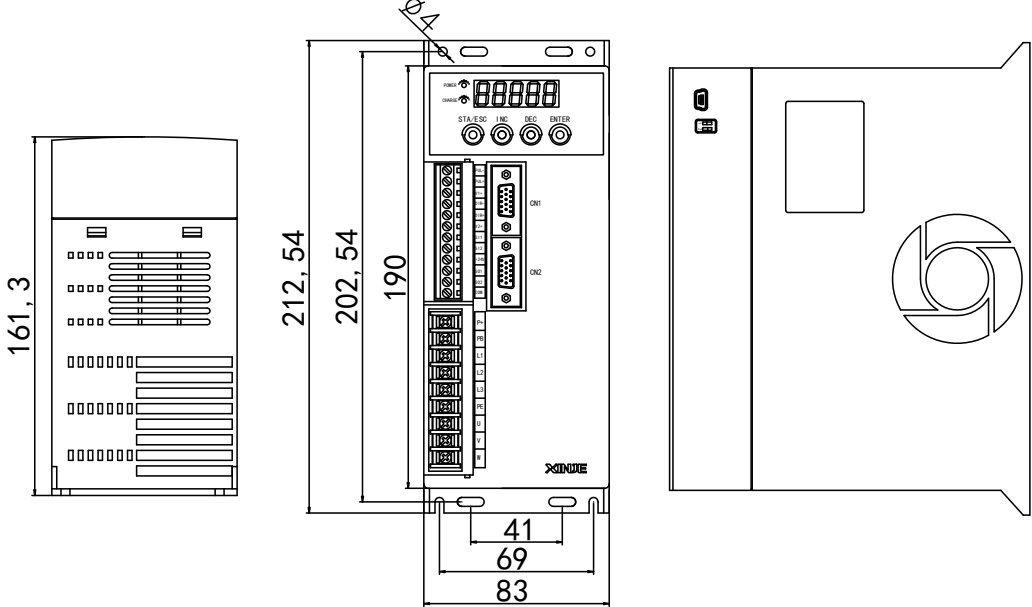

8 Alarm Information

This chapter describes the alarm information of DS2 series servo drivers.

Alarm Code	Description	Reason	Solution
E-001	Program damage	program self-test failed	Re-download the program or contact Xinje or an authorized distributor
E-002	Parameter damage	Parameter self-test failed	Restart the drive to reset the parameters. If it occurs for many times please contact Xinje or an authorized distributor
E-003	Bus over-voltage	Power grid is over voltage or need a regenerative resistor; the regenerative resistor damage or its value is too large	Check the power grid; connect and check the regenerative resistor
E-004	Bus under voltage	Power grid is under voltage	Check the power grid
E-005	Regenerative resistor error	Regenerative resistor is ineffective	Check the connection of regenerative resistor
E-006	Module over temperature	Run with large load for long time	Reduce the load, and enhance the cooling system, or check if the fan is revolving when motor is ON; cool down the ambient temperature
E-007	Over current	UVW of drive is short circuit or the motor is error	Replace the damaged motor; check the UVW wiring.
E-008	Over speed	Motor speed is too fast, motor UVW connection is error	Check if there is other device that make motor revolve too fast; check the UVW wiring.
E-009	Analog input error	Input voltage error when 2-channel analog zero calibrating	Input correct voltage when zero calibration for analog
E-010	Position offset too large	The difference between set position and actual position exceeds the limit value	Check if the motor stalled, decrease the set position speed, increase offset pulse limit value P5-05
E-011	Motor UVW is short circuit	External is short circuit when first self-test	Check the UVW wiring of motor, or replace the damaged motor
E-012	Motor UVW current error	Current collection circuit error	Check the UVW wiring of motor, or replace the damaged drive
E-013	Encoder UVW wire break	Encoder wiring error, encoder broken, encoder is not connected	Check the wiring of encoder, and re-connect the encoder after power-off, or replace the damaged encoder

E-014	Encoder ABZ wire break	Encoder wiring error, encoder broken, encoder is not connected	Check the wiring of encoder, and re-connect the encoder after power-off, or replace the damaged encoder
E-015	Speed changes too fast (encoder feedback error)	The encoder wiring is error, or the encoder has interference	Check the wiring of encoder, or add shield layer for the encoder wire
E-016	Overload	Run overload for long time	Reduce the overload running time, change a motor with larger rated power
E-017	Power off when running	Bus voltage is too low when running	Re-power on after the bus voltage is normal
E-018	Erase parameter error	Voltage is too low when power on, cannot erase the parameter	Check the power supply and re-power on
E-031	Motor code error	Motor code cannot match to drive type	Set the motor code in F2-00 again
E-032	Initialization error	System chip is damaged	Contact Xinje or an authorized distributor

Appendix 1 Parameter list

○ means the parameter can be modified when the servo is OFF, and effective when servo is ON.

● means the parameter can be modified any time, and effective when re-power on the servo.

√ means the parameter can be modified any time, and effective immediately.

Adding “n.” before the parameter means the value is hex.

Parameter: PX-XX = n.xx xx

PX-XX.H ← | → PX-XX.L

P0: function selection

Modbus address: 0000~00FF

P0-	Function	Unit	Default	Range	Effective	Chapter
00	Main mode	-	0	0		5-1
01	Submode 1 0: idle 1: torque (command) 2: torque (analog) 3: speed (command) 4: speed (analog) 5: position (internal) 6: position (pulse) 7: speed (pulse)	-	6	0~7	○	5-1
02	Submode 2 0~7: same as submode 1	-	0	0~7	○	5-1
03	Modbus station of serial port 2	-	1	1~ 255	●	3-5-2
04	Parameter of serial port 2	-	n.2206	n.0000 ~ n.2209	●	3-5-2
05	Rotation direction selection	-	0	0, 1	●	5-2-2
06	06.L: stop mode when servo OFF or alarm. DS2 series default is inertia stop. Keep the inertia motion after stop.	-	2	0~2	●	5-2-4
	06.H: over range (OT) stop mode 0~1: inertia stop. Keep inertia motion after stop. 2: deceleration stop. Change to zero clamp after stop. Torque: P4-06 urgent stop torque. 3: deceleration stop. Change to inertia motion after stop. Torque: P4-06 urgent stop torque.	-	2	0~3	●	5-2-3
07	T-REF distribution 0: undefined. 1: make T-REF as external torque limit input 2: undefined. 3: when P-CL, N-CL is ON, make T-REF as external torque limit input.	-	0	0~3	○	5-5-7
08	V-REF distribution 0: - 1: make V-REF as external speed limit input.	-	0	0, 1	○	5-8-5

P1: control parameters

Modbus address: 0100~01FF

P1-	Name	Unit	Default	Range	Effective	Chapter
00	The gain of speed loop	1Hz	100	1~5000	√	6-1-1
01	Speed loop integral time	0.1ms	400	1~50000	√	6-1-1
02	The gain of position loop	1/s	100	1~2000	√	6-1-2
03	Reserved					
04	The gain of second speed loop	1Hz	250	1~5000	√	6-1-5
05	Integral time of second speed loop	0.1ms	10000	1~50000	√	6-1-5
06	The gain of second position loop	1/s	250	1~2000	√	6-1-5
07	Reserved					
08	Reserved					
09	The gain of position loop feedforward	1%	0	0~100	√	6-1-2
10	Feedforward filter time	0.01ms	0	0~65535	√	

P2: position control

Modbus address: 0200~02FF

P2-	Function	Unit	Default	Range	Effective	Chapter
00	Command pulse state	-	2	1, 2	●	5-3-2
01	Position command filter selection	-	0	0, 1	●	5-3-4
02	Electronic gear ratio (molecular)	-	1	1~65535	○	5-3-3
03	Electronic gear ratio (denominator)	-	1	1~65535	○	5-3-3
04	Position command filter time	1ms	0	0~100	●	5-3-4
05	Reserved					
06	Command pulse frequency at rated speed	100Hz	5000	1~10000	○	5-7-3
07	Speed command pulse filter time	0.1ms	20	0~1000	√	5-7-4
08	Reserved					
09	Reserved					
10	Internal position mode setting	-	n.0000		●	5-4-2
11	First segment pulse (low bit)	1	0	-9999~+9999	○	5-4-3
12	First segment pulse (high bit)	1	0	-9999~+9999	○	5-4-3
13	First segment speed	0.1rpm	0	0~50000	○	5-4-3
14	First segment adjustment time	1ms	0	0~65535	○	5-4-3
15	First segment command filter time	0.1ms	0	0~65535	○	5-4-3
P2-16~P2-90 are 2~16 segments parameter setting.						
94. xx□x	Find the original point 0: invalid 1: valid	-	0	0~1	●	5-4-7
94. xxx□	The signal quantity pass the Z phase signal at the direction of leaving the limit switch	A	2	1~F (Hex)	●	5-4-7
95	The speed of closing the proximity switch	0.1rpm	600	0~50000	○	5-4-7
96	The speed of leaving the proximity switch	0.1rpm	100	0~50000	○	5-4-7

P3: speed control

Modbus address: 0300~03FF

P3-	Name	Unit	Default	Range	Effective	Chapter
00	Analog value of rated speed	0.01V	1000	150~3000	○	5-5-2
01	Internal setting speed 1	rpm	100	-5000~+5000	√	5-6-2
02	Internal setting speed 2	rpm	200	-5000~+5000	√	5-6-2
03	Internal setting speed 3	rpm	300	-5000~+5000	√	5-6-2
04	JOG speed	rpm	100	0~1000	√	4-4-2
05	Soft start acceleration time	1ms	0	0~65535	○	5-5-8
06	Soft start deceleration time	1ms	0	0~65535	○	5-5-8
07	Speed command filter time	0.01ms	0	0~65535	○	5-5-9
08	Speed feedback filter time	0.01ms	20	0~65535	○	5-5-9
09	Max speed limit (MAX speed)	rpm	Different for each type	0~5000	●	5-8-5
10	Speed command input dead area voltage	0.01V	0	0~100	○	5-5-10

P4: torque control

Modbus address: 0400~04FF

P4-	Name	Unit	Default	Range	Effective	Chapter
00	Analog value of rated torque	0.01V	1000	150~3000	○	5-8-2
01	Torque command filter time	0.01ms	0	0~65535	○	5-8-4
02	Forward torque limit	1%	300	0~300	√	5-5-7
03	Reverse torque limit	1%	300	0~300	√	5-5-7
04	Forward external torque limit	1%	100	0~300	√	5-5-7
05	Reverse external torque limit	1%	100	0~300	√	5-5-7
06	Urgent stop torque	1%	300	0~300	○	5-2-3
07	Internal speed limit when torque controlling	rpm	2000	0~5000	○	5-8-5
08	Reserved					
09	Internal torque command setting	1%	0	-300~300	√	5-9-2
10	Torque command input dead area voltage	0.01V	0	0~100	○	5-8-6

P5: signal parameter setting

Modbus address: 0500~05FF

P5-	Name	Unit	Default	Range	Effective	Chapter
00	Positioning finished width /COIN	Command pulse	7	0~250	○	5-3-6
01	Zero clamp speed /ZCLAMP	rpm	10	0~300	○	5-5-5
02	Rotation checking speed /TGON	rpm	20	1~1000	○	5-11-3
03	Coincide speed checking signal width /V-CMP	rpm	10	1~250	○	5-5-6
04	Near output signal width /NEAR	Command pulse	50	0~10000	○	5-3-7
05	Offset pulse limit value	256* command pulse	1000	0~65535	○	6-1-2
06	Servo OFF delay time (brake command)	1ms	0	0~500	○	5-2-5
07	Brake command output speed	rpm	100	0~5000	○	5-2-5
08	Brake command wait time	1ms	500	10~1000	○	5-2-5

09	Input filter time	5ms	0	0~100	√	
10	/S-ON servo signal 0000: signal is always ineffective 0001: input positive signal to SI1 0002: input positive signal to SI2 0003: input positive signal to SI3 0004: input positive signal to SI4 0005: input positive signal to SI5 0006: input positive signal to SI6 0010: signal is always effective 0011: input negative signal to SI1 0012: input negative signal to SI2 0013: input negative signal to SI3 0014: input negative signal to SI4 0015: input negative signal to SI5 0016: input negative signal to SI6	—	※1	※3	●	5-2-1
11	/P-CON proportion action command ditto	—	※1	※3	●	5-5-4
12	/P-OT forward drive prohibition ditto	—	※1	※3	●	5-2-3
13	/N-OT reverse drive prohibition ditto	—	※1	※3	●	5-2-3
14	/ALM-RST alarm reset ditto	—	※1	※3	●	5-11-1
15	/P-CL forward external torque limit ditto	—	※1	※3	●	5-5-7-2
16	/N-CL reverse external torque limit ditto	—	※1	※3	●	5-5-7-2
17	/SPD-D internal speed selection ditto	—	※1	※3	●	5-6-3
18	/SPD-A internal speed selection Same to above	—	※1	※3	●	5-6-3
19	/SPD-B internal speed selection ditto	—	※1	※3	●	5-6-3
20	/C-SEL control mode selection ditto	—	※1	※3	●	5-10
21	/ZCLAMP zero clamp ditto	—	※1	※3	●	5-5-5
22	/INHIBIT command pulse prohibition ditto		※1	※3	●	5-3-8
23	/G-SEL gain switch ditto	—	※1	※3	●	6-1-5
24	/CLR clear pulse offset ditto	—	※1	※3	●	5-3-5
25	/CHGSTP step change signal ditto	—	※1	※3	●	5-4-4
26	Reserved					
27	Reserved					
28	/COIN positioning finished 0000: not output to the terminal 0001: output positive signal from SO1 0002: output positive signal from SO2 0003: output positive signal from SO3 0011: output negative signal from SO1 0012: output negative signal from SO2 0013: output negative signal from SO3	—	※2	※4	●	5-3-6
29	/V-CMP speed coincide checking ditto	—	※2	※4	●	5-5-6
30	/TGON rotation checking	—	※2	※4	●	5-11-3

	ditto					
31	/S-RDY ready ditto	—	※2	※4	●	5-11-4
32	/CLT torque limit ditto	—	※2	※4	●	5-5-7-5
33	/VLT speed limit checking ditto	—	※2	※4	●	5-8-5-3
34	/BK brake lock ditto	—	※2	※4	●	5-2-5
35	/WARN warn ditto	—	※2	※4	●	5-11-2
36	/NEAR near ditto	—	※2	※4	●	5-3-7
37	/ALM alarm ditto	—	※2	※4	●	5-11-1
38	/Z encoder Z signal ditto		※2	※4	●	5-11-5

※1 servo drives input terminal default value: refer to chapter 5-12-2.

※2 servo drive output terminal default value: refer to chapter 5-12-4.

※3 servo drive input terminal distribution: refer to chapter 5-12-1.

※4 servo drive output terminal distribution: refer to chapter 5-12-3.

Modbus address (Hex)

■ Parameter address

Parameter	Modbus address	Parameter	Modbus address	Parameter	Modbus address	Parameter	Modbus address
P0-00	0x0000	P1-00	0x0100	P2-00	0x0200	P3-00	0x0300
P0-01	0x0001	P1-01	0x0101	P2-01	0x0201	P3-01	0x0301
P0-02	0x0002	P1-02	0x0102	P2-02	0x0202	P3-02	0x0302
P0-03	0x0003	P1-03	0x0103	P2-03	0x0203	P3-03	0x0303
P0-04	0x0004	P1-04	0x0104	P2-04	0x0204	P3-04	0x0304
P0-05	0x0005	P1-05	0x0105	P2-05	0x0205	P3-05	0x0305
P0-06	0x0006	P1-06	0x0106	P2-06	0x0206	P3-06	0x0306
P0-07	0x0007	P1-07	0x0107	P2-07	0x0207	P3-07	0x0307
P0-08	0x0008	P1-08	0x0108			P3-08	0x0308
		P1-09	0x0109			P3-09	0x0309
		P1-10	0x010A			P3-10	0x030A
Parameter	Modbus address	Parameter	Modbus address	Parameter	Modbus address	Parameter	Modbus address
P4-00	0x0400	P5-00	0x0500	P5-13	0x050D	P5-26	0x051A
P4-01	0x0401	P5-01	0x0501	P5-14	0x050E	P5-27	0x051B
P4-02	0x0402	P5-02	0x0502	P5-15	0x050F	P5-28	0x051C
P4-03	0x0403	P5-03	0x0503	P5-16	0x0510	P5-29	0x051D
P4-04	0x0404	P5-04	0x0504	P5-17	0x0511	P5-30	0x051E
P4-05	0x0405	P5-05	0x0505	P5-18	0x0512	P5-31	0x051F
P4-06	0x0406	P5-06	0x0506	P5-19	0x0513	P5-32	0x0520
P4-07	0x0407	P5-07	0x0507	P5-20	0x0514	P5-33	0x0521
P4-08	0x0408	P5-08	0x0508	P5-21	0x0515	P5-34	0x0522
P4-09	0x0409	P5-09	0x0509	P5-22	0x0516	P5-35	0x0523
P4-10	0x040A	P5-10	0x050A	P5-23	0x0517	P5-36	0x0524
		P5-11	0x050B	P5-24	0x0518	P5-37	0x0525
		P5-12	0x050C	P5-25	0x0519	P5-38	0x0526

■ Monitor state address

Item	Modbus address	Item	Modbus address
Motor speed	0x0700	current alarm code	0x0716
Speed command	0x0701	Current warn code	0x0717

Internal torque command	0x0702	Alarm/warn code 1	0x0718
Rotation angle (physical angle)	0x0703	U phase current when alarming	0x0719
Rotation angle (electricity angle)	0x0704	V phase current when alarming	0x071A
Bus voltage	0x0705	DC bus voltage when alarming	0x071B
Module temperature	0x0706	IGBT temperature when alarming	0x071C
Input command pulse speed	0x0707	The speed when alarming	0x071D
Offset pulse value (low 16 bits)	0x0708	Internal torque command when alarming	0x071E
Offset pulse value (high 16 bits)	0x0709	V-REF value when alarming	0x071F
Rotation angle (low 16 bits)	0x070A	T-REF value when alarming	0x0720
Rotation angle (high 16 bits)	0x070B	Alarm/warn code 2	0x0728
Input command pulse (low 16 bits)	0x070C	Alarm/warn code 3	0x0729
Input command pulse (high 16 bits)	0x070D	Alarm/warn code 4	0x072A
Feedback pulse (low 16 bits)	0x070E	Alarm/warn code 5	0x072B
Feedback pulse (high 16 bits)	0x070F	Alarm/warn code 6	0x072C
Current accumulated position (low 16 bits)	0x0710	Alarm/warn code 7	0x072D
Current accumulated position (high 16 bits)	0x0711		
Present current	0x0712		
Analog input (speed)	0x0713		
Analog input (torque)	0x0714		

■ Input signal state

Item	Modbus address	Item	Modbus address
/S-ON servo signal	0x0800	/SPD-A internal speed selection	0x0808
/P-CON proportion action command	0x0801	/SPD-B internal speed selection	0x0809
/P-OT forward drive prohibition	0x0802	/C-SEL control mode selection	0x080A
/N-OT reverse drive prohibition	0x0803	/ZCLAMP zero clamp	0x080B
/ALM-RST reset alarm	0x0804	/INHIBIT command pulse prohibition	0x080C
/P-CL forward external torque limit	0x0805	/G-SEL gain switch	0x080D
/N-CL reverse external torque limit	0x0806	/CLR pulse clear	0x080E
/SPD-D internal speed selection	0x0807	/CHGSTP change step	0x080F

■ Output state signal

Item	Modbus address	Item	Modbus address
Positioning finished (/COIN)	0x0812	Brake lock (/BK)	0x0818
Coincidence speed checking (/V-CMP)	0x0813	Warn (/WARN)	0x0819
Rotation checking (/TGON)	0x0814	Near (/NEAR)	0x081A
Ready (/S-RDY)	0x0815	Alarm output (/ALM)	0x081B
Torque limit (/CLT)	0x0816	Encoder Z signal (/Z)	0x081C
Speed limit checking (/VLT)	0x0817		

Appendix 2 Application

Mode 6: pulse command position mode

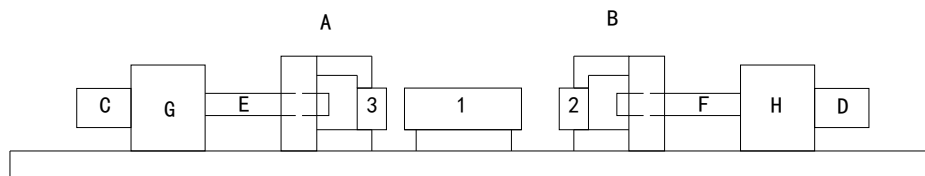

Equipment introduction:

This is a welder. Workpiece 1, 2, 3 are the object to be operated. 2 and 3 is fixed on B and A individually. A and B can whole move and be pushed by ball screw E and F. The screw pitch is 5mm. C and D is servo motor. G and H is reducer. The deceleration ratio is 40.

It needs to adjust the machine with standard dimension workpiece and find the origin of A and B.

Workpiece 1 lies on the worktable and moves left and right. Its dimension is positive tolerance, cannot shorter than standard workpiece. The process to put the workpiece is random. It requires that the left and right soldering is symmetrical.

A and B move toward 1 with 3 and 2 at the same speed. Whatever the position of 1, 2 or 3 will touch 1 at first and push 1 to another side until 2 and 3 all touch 1. The result is the motor torque will increase. At this time, 1 will at the symmetrical position.

A and B will return to the origin position after soldering is finished.

❖ Analysis

1. Make sure the work mode: 6
2. It needs to judge whether 2 and 3 touch 1 when finding the symmetrical point. The sign is servo output torque will increase. It needs to use torque limit (P4-02, P4-03) and torque limit output signal /CLT.
3. As the dimension of workpiece is larger than standard, offset pulse will remain in servo when the symmetrical point is found. /CLR signal can clear the pulse. The servo motor running distance is different from PLC pulse number. If it needs to know the actual distance, servo encoder feedback /AO, /BO and AB phase count are needed.
4. The motion direction of A and B.

❖ Signal and terminal

/COIN positioning finished signal: SO1
 /CLT torque up to upper limit output: SO2
 /CLR pulse offset clear input: SI1
 Encoder feedback signal /AO, /BO

❖ Calculate the electronic gear ratio

Step	Explanation	Ball screw
		$1 \text{ rotation} = \frac{P}{\text{Command unit}}$
1	Confirm the mechanical specification	Ball screw pitch: 5mm Reduction ratio: 40/1
2	Confirm the encoder pulse number	2500P/R
3	Decide the command unit	1 command unit: 0.001mm
4	Calculate the motion value of load shaft rotate 1 circle	5mm/0.001mm = 5000

5	Calculate the electronic gear ratio	$\frac{B}{A} = \frac{2500 \times 4}{5000} \times \frac{40}{1} = \frac{80}{1}$
6	Set the user parameters	P2-02=80 P2-03=1

❖ Parameter setting

Running mode: P0-01=6

Pulse command state: P2-00=2

Electronic gear ratio: P2-02=80 P2-03=1

Forward torque limit: P4-02=150

Reverse torque limit: P4-03=150

Positioning finished width: P5-00=7

/S-ON: P5-10=0010

/CLR: P5-24=0001

/COIN: P5-28=0001

/CLT: P5-32=0002, P5-37=0000

❖ Debug





1. Initial debug

(a) Connect the cables correctly. Connect U, V, W, PE one-to-one, don't cross them.

(b) open-loop test-running: power on, set F1-01=1, check if the motor can work normally. If yes, enter F1-00. If not, check the cables.

(c) Jog test-running: enter F1-00. Press ENTER to enable the motor. Press INC for forward jog, press DEC for reverse jog. Press STATUS/ESC to quit the jog running.

4 states when jogging:

State	Panel display	State	Panel display
Idle		Forward run	
Enable		Reverse run	

(d) Current check offset auto-adjustment

Enter F1-02, it shows rEF.

Press ENTER, it shows rEF and flickers.

After 5s the auto-adjustment finished, it shows donE.

Press STATUS/ESC to exit.

2. Debug the motor with machine

(a) Check the motor rotation direction, if it is reverse from the actual needs, set F1-05 to 0 (servo force OFF). Then set P0-05 to 1, re-power on the servo.

(b) Check the servo stability and response, adjust the servo gain.



Xinje Electronic Co., Ltd.

4th Floor Building 7,Originality
Industry park, Liyuan Development
Zone, Wuxi City, Jiangsu Province
214072

Tel: (510) 85166657

Fax: (510) 85111290

www.xinje.com