

TOSHIBA
Leading Innovation >>>

Spice to the Industry



TOSVERT™
VF-nC3



Simpler
Operation

The “turn-and-push” setting dial makes setup easy.

The large setting dial at the center of the front panel allows you to set the parameters easily. Just turn the setting dial until you get the right parameter and push the setting dial to select.

You can also use the setting dial to set the reference frequency.

The RUN and STOP keys allow to operate easily.

You can operate the inverter with the **[RUN]** and **[STOP]** keys on the front panel. The front cover may be closed to conceal the other keys to avoid accidental key presses.



Easy to set parameters

① **In Easy mode, you can navigate through only the most commonly used parameters.**

The EASY key allows you to switch between Easy mode and Standard mode

Easy mode : Scrolls through a list of only eight parameters. You can optionally add up to 24 parameters to the list.

Standard mode : Rotates through all parameters.

② **Guides you step by step through parameters you need to set up**

Since the guidance feature shows one parameter at a time according to the selected function, you can interactively edit its value.

Auto-guidance function is available with motor parameter setup, preset speed selection, analog signal control and etc.



Built-in RS-485 communication

Built-in RS-485 communication enable to control the inverter and construct the inverter and construct the network.

- Communication rate maximum 38.4 kbps
- Compatible with the Modbus RTU and Toshiba protocols.

You can connect a PC to manage parameters and monitor operating conditions.



The vertically oriented main circuit terminal block allows easy wiring.

Like power distribution devices, the main circuit terminal block of the VF-nC3 is vertically oriented to make wiring easy and minimize tangles of cable.

Side-by-side installation for space-saving

Generally, inverters must be placed, taking heat dissipation into consideration. The VF-nC3 can be placed side by side with no gap, saving inside of control panel space.*1

The covers for the main circuit terminal block ensure safety.

You can remove the covers for the main circuit terminal block with a screwdriver. Since the covers can be attached after the wiring of the main circuit terminal block, the VF-nC3 can be installed easily and safely.



Wide Operating Conditions and Compliance with Global Standards

- ① **Maximum ambient temperature:** 60°C*1
- ② **Maximum altitude:** 3000 meters*1
- ③ **Support for single-phase power supply** : Supports three-phase 240V, single-phase 240V and single-phase 120V power supplies. Note : For single-phase 240V and 120V inputs, the VF-nC3 provides a three-phase 200V output.
- ④ **Compliant with global standards:**

*1: Necessary to reduce output current on some conditions.



Simple & Compact inverter TOSVERT™ VF-nC3

Simpler
Installation

Models and Applicable Motors

Voltage (Input / Rated Output)	Applicable Motor Capacity (kW)						
	0.1	0.2	0.4	0.75	1.5	2.2	3.7
1ph-120V/3ph-200V	[Shaded]						
1ph-240V/3ph-200V	[Shaded]						
3ph-240V/3ph-200V	[Shaded]						

Applications

Conveyance machinery, food processing machinery, packing machinery, health / medical / nursing care equipment, environment / daily-life-related machinery, general industrial pumps and fans

Excellent Motor Control

- **High torque**
Sensorless vector control provides stable torque right from the start of a motor to the rated rotation speed. You just enter the values on the name plate of a motor, and set the Auto-tuning parameter.
- **Energy-saving mode**
Energy-saving mode enable to reduce energy consumption for fans and pumps.

Long Lifetime

- **Designed for 10 years of operation**
The main-circuit capacitor, cooling fan and control-board capacitors are designed for long life to achieve design lifetime of 10 years.
(Conditions: Average annual ambient temperature = 40°C; output current = 80% of the maximum rated value; 24 hours / 365 days uninterrupted)
The cooling fan is automatically turned on and off to further prolong the lifetime.
- **Monitors when to replace major parts**
The VF-nC3 has the function to monitor and output warning when to replace major parts and keep track of the cumulative operation time.

Safety Features

- **Protects the setting parameters**
The VF-nC3 provides protection for the setting parameters. For enhanced security, you can use a four-digit password.
Additionally, the VF-nC3 has a feature for saving and restoring a set of parameters in one go.

Eco Design

- **Compliant with the EU RoHS**
- **Built-in noise filters to minimize electromagnetic noise emitted to the environment**
The single-phase 240V model has a built-in EMC noise filter to reduce radio-frequency noise from the inverter.
This saves space and wiring, compared to using an external noise filter.

Standard specification

Item		Specification						
Input voltage class		1-phase 120V / 1-phase 240V / 3-phase 240V						
Applicable motor (kW)		0.1	0.2	0.4	0.75	1.5	2.2	3.7
Model	Input voltage class	VFNC3 / VFNC3S						
	1-phase 120V	VFNC3S-	1001P	1002P	1004P	1007P	—	—
	1-phase 240V	VFNC3S-	2001PL	2002PL	2004PL	2007PL	2015PL	2022PL
	3-phase 240V	VFNC3-	2001P	2002P	2004P	2007P	2015P	2022P
Rating	Output capacity (kVA) ^{Note 1)}	0.3	0.6	1.3	1.8	3.0	4.2	6.7
	Output current (A) ^{Note 2)}	0.7 (0.7)	1.4 (1.4)	2.4 (2.4)	4.2 (3.2)	7.5 (7.1)	10.0 (7.5)	16.7 (14.0)
	Output voltage ^{Note 3)}	3-phase 200V to 240V						
Power supply	Voltage-frequency	1-phase 120V class: 1-phase 100V to 120V-50/60Hz 1-phase 240V class: 1-phase 200V to 240V-50/60Hz 3-phase 240V class: 3-phase 200V to 240V-50/60Hz						
	Allowable fluctuation	1-phase 120V class: Voltage 85 to 132V ^{Note 4)} , frequency ±5% 1-phase 240V class: Voltage 170 to 264V ^{Note 4)} , frequency ±5% 3-phase 240V class: Voltage 170 to 264V ^{Note 4)} , frequency ±5%						
Feature	Output voltage range	Adjustable within the range of 50 to 330V by correcting the supply voltage (not adjustable above the input voltage) ^{Note 3)}						
	Output frequency range	0.1 to 400Hz, default setting: 0.5 to 80Hz, maximum frequency: 30 to 400Hz						
	Voltage / frequency characteristic	V/f constant mode, variable torque mode, automatic torque boost mode, vector control mode, automatic energy-saving mode. Auto-tuning.						
	Overload current rating	150%-60 seconds,						
Environments	Functions	PID control, regenerative power ride-through control, auto-restart control, dynamic deceleration control, frequency UP/DOWN input control, 3-wire control, RS485 communication (2-wire), programmable input/output terminal, voltage/current analogue output, pulse train output, parts replacement alarming signal monitor / output, detailed monitor display at trip, free unit selection, password lock, guidance function, history function, etc.						
	Use environments	Indoor, not exposed to direct sunlight, without corrosive gas, explosive gas, oil mist, dust and dirt etc Altitude: 3000m max.(output current needs to be reduced for altitude above 1000m) Vibration: less than 5.9m/s ² (10 to 55Hz)						
Ambient temperature / Relative humidity		-10 to +60°C (Above 40°C, remove the protective seal from the top face, and use the inverter with the output current reduced) / 5 to 95% (free from condensation and vapor).						
Protective method / cooling method		IP20 Enclosed type (JEM1030) / Self-cooling (0.4kW or less of 1-phase 120V input class)				IP20 Enclosed type (JEM1030) / Forced air-cooled		
Built-in filter		1-phase 240V class : High attenuation EMI filter , 1-phase 120V class and 3-phase 240V class: no filter						

Note 1.) Output capacity is calculated at 220V .

Note 2.) In case of the PWM carrier frequency setting:4kHz or less, Value in parentheses indicates in case of 5kHz to 12kHz. It is necessary to further reduce the output current incase of 13kHz or more. Default setting:12kHz

Note 3.) Maximum output voltage is the same as the input voltage. In case of 1-phase 120V class, maximum output voltage is the same as twice the input voltage.

Note 4.) ±10% when the inverter is used continuously (load of 100%).

Standard connection diagram(sink logic)

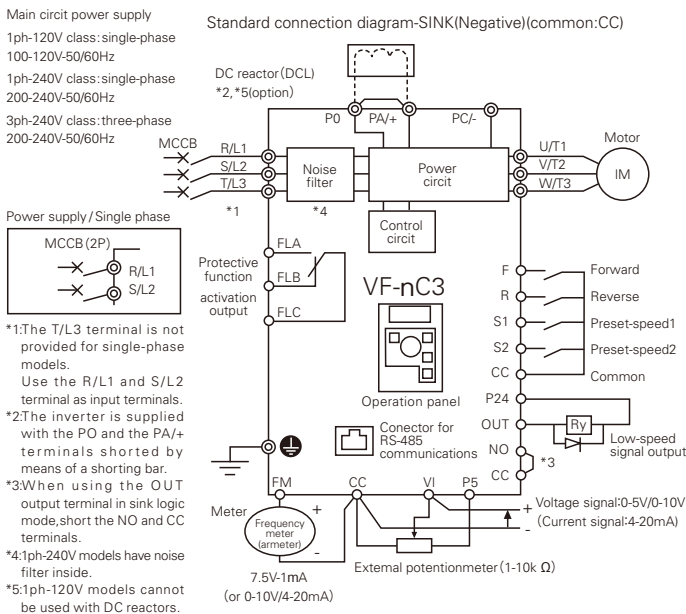

Standard connection diagram (source logic)

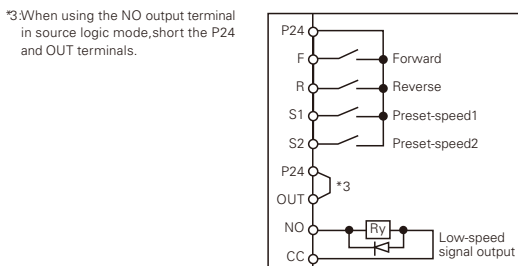

External dimensions and weight

Input Voltage class	Applicable motor (kW)	Inverter model	Dimensions (mm)			Approx. weight (kg)
			Width	Height	Depth	
1-phase 120V	0.1	VFNC3S-1001P	72	130	102	1.0
	0.2	VFNC3S-1002P			121	
	0.4	VFNC3S-1004P	156			
	0.75	VFNC3S-1007P	105			
1-phase 240V	0.1	VFNC3S-2001PL	72	130	102	1.0
	0.2	VFNC3S-2002PL			121	
	0.4	VFNC3S-2004PL	131			
	0.75	VFNC3S-2007PL	156			
	1.5	VFNC3S-2015PL	105			
3-phase 240V	0.1	VFNC3-2001P	72	130	102	1.0
	0.2	VFNC3-2002P			121	
	0.4	VFNC3-2004P			131	
	0.75	VFNC3-2007P	105		156	
	1.5	VFNC3-2015P			131	
	2.2	VFNC3-2022P			141	
	3.7	VFNC3-2037P			170	

To users of our inverters : Out inverters are designed to control the speeds of three-phase induction motors for general industry.

Precautions

- ▼ Read the instruction manual before installing or operating the inverter unit, and store it in a safe place for reference.
- ▼ When using our inverters for critical equipment such as nuclear power control, aviation and space flight control, traffic and safety, and there is a risk that any failure or malfunction of the inverter could directly endanger human life or cause injury, please contact our headquarters, branch or offices printed on the back cover of this catalogue. Special precautions must be taken and such applications must be studied carefully.
- ▼ When using our inverters for critical equipment, even though the inverters are manufactured under strict quality control always fit your equipment with safety devices to prevent serious accident or loss should the inverter fail (such as issuing an inverter failure signal).
- ▼ Do not use our inverters for any load other than three-phase induction motors.
- ▼ Note of Toshiba, its subsidiaries or agents, shall be liable for any physical damages, including without limitation, malfunction, anomaly, breakdown or any other problem that may occur to any apparatus in which the Toshiba inverter is incorporated to any equipment that is used in combination with the Toshiba inverter. Nor shall Toshiba, its subsidiaries, affiliates or agents be liable for any compensatory damages resulting from such utilization, including compensation for special, indirect, incidental, consequential, punitive or exemplary damages, or for loss of profit, income or data, ever if the user has been advised or apprised of the likelihood of the occurrence of such loss or damages.

For further information, please contact your nearest Toshiba Representative or International Operations-Producer Goods. The information in this brochure is subject to change without notice.

TOSHIBA INDUSTRIAL PRODUCTS SALES CORPORATION

International Operations 9-11, Nihonbashi-honcho 4-chome, Chuo-ku, Tokyo 103-0023, Japan Tel : +81-(0)3-5644-5509, FAX : +81-(0)3-5644-5519