

Instruction Manual

3U Rack-Mount

AC Servo Modules

MSK 6

MSK 12

Power Supply Module

MTB 25

All data in this manual is informative.

Specifications are subject to change without notice.

Contents

Page

1.	Safety regulations.....	4
2.	Technical specifications.....	5
3.	Installation	7
3.1.	Conductor cross sections	7
3.2.	Inputs and outputs	7
3.3.	Motherboard connections (MB-MSK).....	9
3.4.	Connections on the front of the servo module	10
3.5.	Motherboard connections (MB-MTB)	10
3.6.	Selection of transformers.....	11
3.7.	Connecting the servo motor.....	11
4.	Set-up Procedure	11
5.	Functions and Options.....	12
5.1.	Function of the controls and indicators on the MSK 6/12 modules.....	12
5.1.1.	Test jacks.....	12
5.1.2.	LED indicators.....	12
5.2.	Controls	13
5.3.	Indicators on the power supply module MTB-25	14
5.4.	Personality module	14
5.4.1.	RMS current limitation	14
5.4.2.	Peak current limitation.....	15
5.4.3.	RMS and peak current limitation with fixed resistors	15
5.4.4.	Components on the personality module	16
5.4.5.	Location of the personality module.....	17
5.4.6.	Input circuitry - velocity controller incl. personality module	18
5.5.	Options	19
5.5.1.	Encoder simulation "ES1"	19
5.5.2.	Option "24 V external"	19
5.5.3.	Optional power supply "24 V external" with integrated power dump resistor	20
6.	Trouble shooting.....	20
6.1.	Fuses MSK 6/MSK 12	20
6.2.	Fuses - MTB 25.....	21
6.2.1.	Fuses - optional power supply.....	21
6.3.	Trouble shooting table	22
7.	Connection diagrams.....	27
7.1.	Connection diagram - MTB-25.....	27
7.2.	Connection diagram - MTB-25/MSK 6/MSK 12 with option "24V external".....	28
7.3.	Connection diagram MSK 6/MSK 12 with motors M254-M506 and F504-F804	29
7.4.	Front panel - MSK 6 / MSK 12 and MTB 25.....	30
7.5.	Dimensions.....	31
8.	Ordering details	32
8.1.	Order code for MSK, MTB and motherboards	32
8.2.	Order code for power dump resistors	33
8.3.	Order code for rack system	33
9.	Appendix.....	34
9.1.	Transformer dimensions and order code	34
9.2.	Motor cables.....	34
9.3.	Resolver cable.....	34

1. Safety regulations

Installation and start-up should be performed by skilled and qualified staff, observing valid VDE regulations.

VDE 0100 (Erection of Electrical Power Installations with Rated Voltages Lower Than 1000 V).

VDE 0130 (Electrical Equipment of Manufacturing and Processing Machines).

VDE 0160 (Assembly of Electronic Equipment in Power Installations).

The AC input power to the module has to be supplied by an isolated transformer (see VDE 0550).

The negative U_z bus has to be grounded (connection to the 19" rack is provided by the motherboards).

For the motor an earth connection is required (PE connection on the motherboards).

The negative U_z bus (PE) has to be connected to the ground point in the cabinet.

The minimum gauge of the motor and supply cables has to be rated according to VDE 0100. Please ensure an ample rating when using longer cables.

Motor and resolver cables must be shielded and connected to the motherboard on one side.

The resolver lead wires should be run as twisted pairs.

The cable for the velocity command signal has to be shielded and connected to the module on one side.

The use of a potential free standby contact in the safety circuit of the machine will increase the operating safety of the system.

Before clearing a fault by means of the reset command eliminate the cause and make sure that carrying out the command is not dangerous.

When working on, or in the vicinity of the machine the power must be disconnected from the drive in accordance with VDE 105.

Note: Removing the "Enable" signal is not sufficient to disconnect the power!

The modules must be mounted in the vertical position.

Filtered air ($V_u \leq 45^\circ\text{C}$) is required for cooling.

The modules may only be inserted and removed after disconnecting the power (the modules are without any potential after 5 seconds).

When using the option "24 $V_{ex.}$ " it is necessary to observe the specified switch-on sequence: connect the 24 $V_{ex.}$ auxiliary voltage first and then apply AC power.

Switch-off is in the reverse sequence.

2. Technical specifications

Rated values

Bus voltage	120 V DC (55 V DC...140 V DC)
Logic voltage (internal)	+15 V, 600 mA; -15 V, 400 mA
Rated output voltage	74 V _{rms} (3 × 34 V _{rms} ...83 V _{rms})
Rated output current	MSK 6: 3 × 4.2 A _{rms} MSK 12: 3 × 8.5 A _{rms}
Peak output current	MSK 6: 3 × 8.8 A _{rms} MSK 12: 3 × 17.6 A _{rms}

Protection (internal)

DC bus	MSK12: 16 A mb (5 × 20 mm) / MSK6: 8 A mb
Auxiliary voltage	630 mA mb 1.25 A mb with 24 V option
Tripping threshold for over-voltage	> 170 V
Tripping threshold for over-temperature	> 85°C
Chopper frequency of the output stage	9.8 kHz
Bandwidth of the current controller	> 1.5 kHz
Auxiliary DC outputs	± 15 V, 10 mA
Resolver voltage	7.07 V _{rms} , 10 kHz
Vel. command input 1 via ramp generator	± 10 V, R _i = 20 KΩ 50-500 ms, 10 V, 0...100%
Vel. command input 2	± 10 V, R _i = 20 KΩ
Current limitation input (2 × I _n)	0...10 V, R _i = 1 KΩ
Enable	PLC compatible, 11-33 V DC; active High
Limit switch enable (forward)	PLC compatible, 11-33 V DC; active High
Limit switch enable (reverse)	PLC compatible, 11-33 V DC; active High
Reset	PLC compatible, 11-33 V DC; active High; 1ms

Outputs

Controller busy	open collector, active Low 35 V DC, 20 mA
I ² × t limit	open collector, active Low 35 V DC, 20 mA
Ready relay	relay energised, 24 V DC, 500 mA NC
Brake relay	relay energised, 24 V DC, 500 mA NC

Options:

Encoder simulation (opto-isolated)

External power supply	+ 5 V DC, 50 mA
Output level	5 V (RS 422)
Output signals	A, \bar{A} , B, \bar{B} , and gated I, \bar{I}
Resolution	adjustable 128, 256, 512, 1024 counts per revolution

External 24 V DC power supply:

Auxiliary voltage 24 V DC, 500 mA (18...30 V DC)

Monitor devices

Current monitor $0... \pm 2 \times I_n \hat{=} 0... \pm 10 \text{ V}$
 Velocity monitor $0... \pm 8000 \text{ rpm} \hat{=} 0... \pm 8 \text{ V}$

Power supply MTB 25

Rated connection voltage $3 \times 85 \text{ V}_{\text{rms}}$ (40 V_{rms} ...95 V_{rms})
 Rated output voltage 120 V DC (55 V DC...140 V DC)
 Rated input current $3 \times 20 \text{ A}_{\text{rms}}$
 Rated output current 25 A DC
 Mains fuses (internal) $3 \times 16 \text{ A sb}$ (5 × 20 mm)
 Peak power of dump circuit 3.2 kW
 with external resistor 8 Ω , 500 W
 Continuous power of power dump circuit 500 W
 Switching threshold of power dump circuit $U_z + 15 \text{ V}$
 Protection of the dump circuit 8 A sb (5 × 20 mm)

Option:**Internal dump resistor and auxiliary power supply 24 V DC**

Peak power of the internal dump resistor 650 W
 Continuous power of the internal
 dump resistor without/with forced cooling 30 W / 60 W
 Rated value of the auxiliary voltage 24 V DC (20...28 V DC)
 Rated current (1-phase/3-phase supply) 2 A DC/4 A DC
 Rated input voltage $1 \times 19 \text{ V}_{\text{rms}} / 3 \times 19 \text{ V}_{\text{rms}}$ (15.5...21 V_{rms})
 Rated input current (1-phase/3-phase) $1 \times 3 \text{ A}_{\text{rms}} / 3 \times 3.3 \text{ A}_{\text{rms}}$
 Protection of the auxiliary voltage $3 \times 4 \text{ A mb}$ (5 × 20 mm)

3. Installation

Environment

The ambient temperature must be between 0 and 45 °C. If this is not guaranteed, the output current has to be linearly reduced from I_n at 45 °C down to 0 A at 85 °C. If the RMS current is higher than 6.3 A_{rms} forced cooling is generally required. Forced cooling is also necessary for multilevel arrangement of 2 or more racks, even with low RMS currents. In this case a fan has to be provided under every one or two modules. In multilevel arrangement the modules subjected to the greatest loads must be on the bottom. Similarly, the power supply module MTB 25 also has to have forced cooling from 20 A DC and above. If the load of the built-in dump resistor of the 24 V power supply option is higher than 30 W, a fan must be installed under the power supply module or under a power supply module and a servo module. An air velocity of 5 - 10 m/sec is generally sufficient. If the cabinet has an external cooling system, the supply air must be filtered. The maximum relative humidity is 90% non-condensing. The maximum altitude is 1000 m above sea level.

3.1. Conductor cross sections

Motor cables:	4 × 1.5 mm ² minimum
Resolver cables:	4 × 2 × 0.14 mm ² , twisted pairs
Velocity command signals:	0.14 mm ² , twisted pairs
Control signals:	0.28 mm ²
Power cable:	4 × 2.5 mm ² minimum
24 V external:	2 × 1 mm ² minimum

For the initial set-up suitable cable sets in graduated lengths are available from Messrs. Bautz (see Appendix).

For the suppression of EMI the motor cable as well as the resolver cable must be shielded. The shielded cable should be connected on one side of the motherboard of the module. If the motor lead is not shielded, it should not run parallel with the resolver and velocity command signal.

3.2. Inputs and outputs

The voltage for the limit switches can be supplied both from an external 24 V source or internally (+15 V int. - pin 6). The reference ground is pin 3 or 9 on the front panel Sub-D connector (GND).

Note: This reference ground is not isolated from PE / -U_z !

When the corresponding limit switch is activated the motor is actively braked to standstill, the brake relay is then opened and after approx. 20 ms the servo module is disabled. Emergency switch-off caused by simultaneous opening of both limit switches ensures fast braking followed by opening of the brake relay. On the other hand, by removing the enable signal the drive is immediately disabled and the brake relay opens immediately.

The rating for both relays is 24 V DC, 0.5 A. Therefore a power relay is required for a motor brake. This relay must be protected by varistors etc. The outputs "I² × t" and "Controller busy" are open collector outputs for max. 33 V DC, 20 mA. The reference ground is pin 4.

When the current of the servo module rises above its rated RMS value, the output " $I^2 \times t$ " becomes active (low resistance).

The output "Controller busy" indicates the standby status of the servo module, and that "enable" and the "limit" switches are closed.

The "Reset" input clears a fault message stored in the memory. This input should be activated for only about 1 ms; the cause of the fault should be removed first.

The " I_{max} extern" input is provided for external current limitation using a DC voltage 0 - 10 V DC. The internal resistance should not be greater than 100 Ω . Also, a potentiometer of 10 K Ω may be used.

The reference ground is pin 3 or 9 of the front connector.

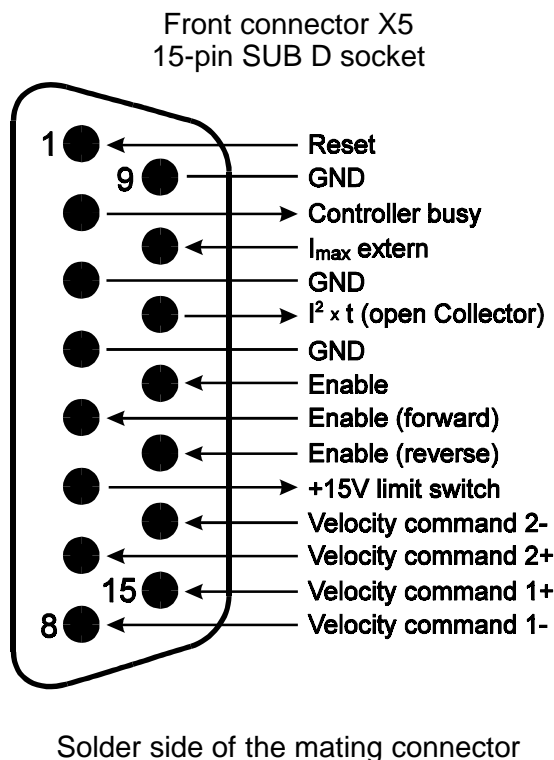

3.3. Motherboard connections (MB-MSK)

	Connector	Pin	Function	Cross section
	X1	1	Soldering pin +Vcc	min. 2.5 mm ²
	X2	1	Soldering pin -Vcc	min.2.5 mm ²
OPTION encoder- simulation	X3	1	$\overline{\text{Index}}$	0.14 mm ²
		2	$\overline{\text{A}}$	0.14 mm ²
		3	$\overline{\text{B}}$	0.14 mm ²
		4	+5 V external	0.14 mm ²
		5	nc	
		6	Index	0.14 mm ²
		7	A	0.14 mm ²
		8	B	0.14 mm ²
		9	GND external	0.14 mm ²
	X4	1	GND + motor shield	min. 1.5 mm ²
2		Phase T (motor)	min. 1.5 mm ²	
3		Phase S (motor)	min. 1.5 mm ²	
4		Phase R (motor)	min. 1.5 mm ²	
	X6	1	+15 V, 10 mA aux. voltage	0.14 mm ²
2		GND of auxiliary voltage	0.14 mm ²	
3		-15 V, 10 mA aux. voltage	0.14 mm ²	
	X7	1	N _{SOLL} = Veloc.command 2- internally for PTS	ribbon cable
2		N _{SOLL} = Veloc.command 2+ internally for PTS	ribbon cable	
3		Internal enable for PTS	ribbon cable	
4		GND	ribbon cable	
5		Encoder A for PTS	ribbon cable	
6		Encoder B for PTS	ribbon cable	
7		PTS error	ribbon cable	
8		nc		
9		nc		
10		nc		
	X8	1	Brake relay 24 V, 500 mA	min. 0.5 mm ²
2		Brake relay 24 V, 500 mA	min. 0.5 mm ²	
	X9	1	Thermo switch for motor	0.14 mm ²
2		Thermo switch for motor	0.14 mm ²	
3		Excitation voltage R2	0.14 mm ²	
4		Excitation voltage R1	0.14 mm ²	
5		Resolver Sine S4	0.14 mm ²	
6		Resolver Sine S2	0.14 mm ²	
7		Resolver Cosine S1	0.14 mm ²	
8		Resolver Cosine S3	0.14 mm ²	
9		Shield		
OPTION 24V ext.	X10	1	Opt. +24 V external	1 mm ²
		2	Opt. GND for 24V ext.	1 mm ²
	X11	1	Standby relay 24 V, 500 mA	0.5 mm ²
2		Standby relay 24 V, 500 mA	0.5 mm ²	

3.4. Connections on the front of the servo module

Connector	Pin	Function	Cross section
X5	1	Reset	0.14 mm ²
	2	Controller busy, open collector	0.14 mm ²
	3	GND	0.14 mm ²
	4	GND	0.14 mm ²
	5	Enable (forward)	0.14 mm ²
	6	+15 V for limit switch ?	0.14 mm ²
	7	Veloc. command 2+	0.14 mm ²
	8	Veloc. command 1-	0.14 mm ²
	9	GND	0.14 mm ²
	10	I _{max} external	0.14 mm ²
	11	I ² × t limit, open collector	0.14 mm ²
	12	Enable	0.14 mm ²
	13	Enable (reverse)	0.14 mm ²
	14	Veloc. command 2-	0.14 mm ²
	15	Veloc. command 1+	0.14 mm ²

3.5. Motherboard connections (MB-MTB)

	Connector	Pin	Function	Cross section
	X1	1	Soldering pin +Vcc	min. 2.5 mm ²
	X2	1	Soldering pin -Vcc	min. 2.5 mm ²
	X4	1	PE isolation transformer	min. 2.5 mm ²
		2	L1: 85 V _{rms}	min. 2.5 mm ²
		3	L2: 85 V _{rms}	min. 2.5 mm ²
		4	L3: 85 V _{rms}	min. 2.5 mm ²
	X5	1	RB+ ext. dump resistor	min. 1.5 mm ²
		2	RB- ext. dump resistor	min. 1.5 mm ²
OPTION 24V ext.	X6	1	19 V _{rms} for 24 V external	min. 1 mm ²
		2	19 V _{rms} for 24 V external	min. 1 mm ²
		3	19 V _{rms} for 24 V external	min. 1 mm ²
OPTION 24V ext.	X7	1	24 V DC output 4 A DC	min. 1 mm ²
		2	24 V DC GND	min. 1 mm ²

3.6. Selection of transformers

The following transformers to VDE 0550 are available for servo modules of series MSK 6 / 12:

Type	VA	Rating Primary	Secondary	Auxiliary
TO65.1	0.5 kVA	1 × 230 V _{rms}	1 × 85 V _{rms} / 5.5 A	1 × 19 V / 1.5 A
TO66.1	1 kVA	1 × 230 V _{rms}	1 × 85 V _{rms} / 11 A	1 × 19 V / 2.5 A
TO118.1	1 kVA	3 × 400 V _{rms}	3 × 85 V _{rms} / 6.3 A	3 × 19 V / 2.5 A
TO119	2.3 kVA	3 × 400 V _{rms}	3 × 85 V _{rms} / 15.1 A	3 × 19 V / 2.5 A

Before connecting the transformer to the power supply module measure the secondary voltage with a voltmeter.

For transformers over 3 kVA a soft-start has to be provided.

When using the external 24 V supply it is necessary to provide a power relay in the secondary 85 V; this relay is energised by the auxiliary 24 V voltage.

In this way the correct switching-on and switching-off sequence is assured. The relay also ensures "safe removal of power" in the event of an emergency switch-off.

3.7. Connecting the servo motor

The MSK modules may be used in conjunction with all motors of series M254...M506 and F50...F80. A personality module is used to match the controller to the motor; the personality module is accessible by removing the front panel. Please note the necessary RMS current matching for the thermal protection of the motors. (see page 14 and 15).

On request the modules are delivered with already adjusted personality modules.

4. Set-up Procedure

Please read the safety instructions given in chapter 1!

Check the wiring according to the diagrams in chapter 7.

Check the name plates of the controller, motor and transformer for the right voltage, current and correct wiring.

Make sure that the trimming potentiometers are set in their normal position (see page 13).

Check that the earth connections are correct (common ground point), especially the shield of the transformer. Make sure no damage is done in case the motor accelerates towards full speed.

Set the I_{max} potentiometer close to the fully CCW position to limit the maximum torque of the motor.

When switching the drive on for the first time, disable the drive and then apply AC power (if using the 24 V option, make sure that the switching sequence is in the specified order).

When AC power is applied and the controller enabled, move the axis in both directions at slow speed. Check that the polarity of the velocity command signal and the direction of rotation of the motor are correct.

Adjust all potentiometers (N_{ist} , N_{soll} , offset, Gain, I_{max} and I_{rms}).

If further axes are to be put into operation, make sure that the power has been safely removed from the system before the modules are inserted.

5. Functions and Options

5.1. Function of the controls and indicators on the MSK 6/12 modules

5.1.1. Test jacks

There are 2 test jacks (2 mm) for the actual value of velocity and current.

Velocity monitor "VEL"	1 V	$\hat{=}$ 1000 rpm
Current monitor "CUR"	1 V	$\hat{=}$ 20 % of the rated current

The reference ground is the "GND" jack.

To avoid earth circuit always use potential-free oscilloscopes or isolation transformers. Likewise, the GND jack should be free of any other connections.

5.1.2. LED indicators

"LIM" LED

Indicates that one or both limit switches were hit. For normal operation both limit switches must be closed.

" $I^2 \times t$ " LED

This LED is turned on if the permissible peak current was drawn for too long.

LED "Über-Temp" (over-temperature)

This LED is turned on if the temperature in the module exceeds 85 °C or when the thermo switch responds.

If a thermo switch is not provided, pins 1 and 2 of X9 on the motherboard of the servo module have to be bridged.

LED "Überstrom" (over-current)

All MSK servo modules are protected against short-circuit phase to phase and phase to ground. If a short-circuit occurs the servo module is switched off and the LED "Überstrom" lights.

LED "+ 15 V def" (auxiliary voltage error)

This LED lights if one or both of the auxiliary voltages drops below 14 V.

LED "Überspg" (over-voltage)

This LED lights if the DC bus voltage exceeds 170 V.

LED "Unterspg" (under-voltage)

This LED lights if the DC bus voltage drops below 55 V or if the AC power is off when using the option "24 V external".

The fault messages "Übertemp", "Überstrom" and "Überspg" are stored in a memory. At the same time the standby relay and the brake relay are de-energised and the output "Controller busy" relay contacts open.

The fault messages may be cleared with a "Reset" signal on pin 1 of the front connector X5, or by switching the AC power off and then on again. Please remedy the fault condition before you reset!

5.2. Controls

Potentiometer "dn/dt"

This potentiometer sets the slope of the velocity command integrator (50 ms - 500 ms) for velocity command input 1. The basic setting is fully CCW.

Potentiometer "N_{ist}"

This potentiometer reduces the tacho gain, i.e. the motor speed can be increased while the velocity command signal remains unchanged. The basic setting is fully CCW.

Potentiometer "N_{soll}"

This potentiometer reduces the velocity command gain. The potentiometer is active on both input channels. The basic setting is fully CW.

Potentiometer "offset"

This potentiometer is used to adjust the speed drift of the drive with a velocity command signal of 0 V.

(Note: Unused velocity command inputs have to be short-circuited.)

Potentiometer "Gain"

This potentiometer increases the gain of the velocity controller. By turning it CW both the proportional and integral component increase uniformly. For special applications the individual parameters on the personality module may be changed. The basic setting is fully CCW.

Potentiometer "I_{max}"

By turning this potentiometer CCW it is possible to reduce the peak current linearly down to zero. The basic setting is fully CW.

Potentiometer "I_{rms}"

By turning this potentiometer CCW the RMS current of the servo module may be reduced down to 25% of the rated current. The control range has a quadratic character, i.e. the central position corresponds to about 70 % of the rated current of the servo module. For exact matching of controller and motor please consult table 2 on page 15. The basic setting is fully CW.

DIL switches for setting the pole pairs:

No. of motor pole pairs	S 2a	S 2b
2	off	on
3 (Standard)	off	off
4	on	off
8	on	on

Table 1

5.3. Indicators on the power supply module MTB-25

The power supply modules of series MTB generate the bus voltage for the AC servo modules of series MSK.

An external single-phase or three-phase isolation transformer delivers the required input power.

With single-phase operation the power output is reduced. The power supply module MTB 25-AB has an internal power dump resistor and an auxiliary voltage of 24V.

LED "U_z"

This LED will be on if voltage is present on the DC bus. Do not remove the MTB 25 from the rack when this LED is on!

LED "Ballast" (power dump)

Lights during braking of the drive when the energy generated by the motor is being converted into heat in the power dump resistor. When the supply voltage is switched off the dump circuit quickly discharges the capacitors. Please use power dump resistors as specified in the appendix (the option "24 V external" has a built-in power dump resistor).

5.4. Personality module

All parameter setting options are contained on a small pc board. This allows optimum adaptation of the servo module to a certain motor and to the motion control application in question. The pc board can be configured into a personality module if the specific parameters are designed with fixed resistors and jumpers.

The following components are placed on solder-type sockets and may be changed:

Designation	Function	Value (Standard)
R98	Proportional gain	150 KΩ
C9	Time constant	100 nF
R83	I _{max} limit	open
R87	I _{rms} limit	open

5.4.1. RMS current limitation

The resistor R87 limits the RMS current of the servo module:

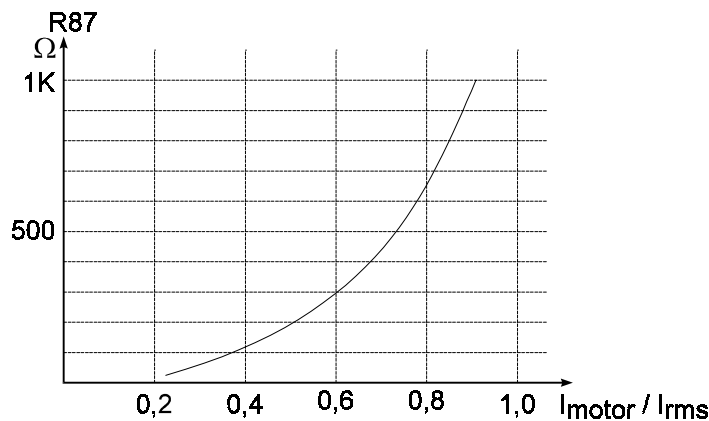

Fig. 1

Example: Servo motor M406D, I_n = 5.6 A_{rms} in conj. with MSK 12, I_{rms} = 8.5 A

$$\frac{I_n}{I_{rms}} = \frac{5.6A}{8.5A} = 0.6 \quad \text{i.e. } R87 = 390\Omega$$

5.4.2. Peak current limitation

The resistor R83 limits the peak current of the servo module:

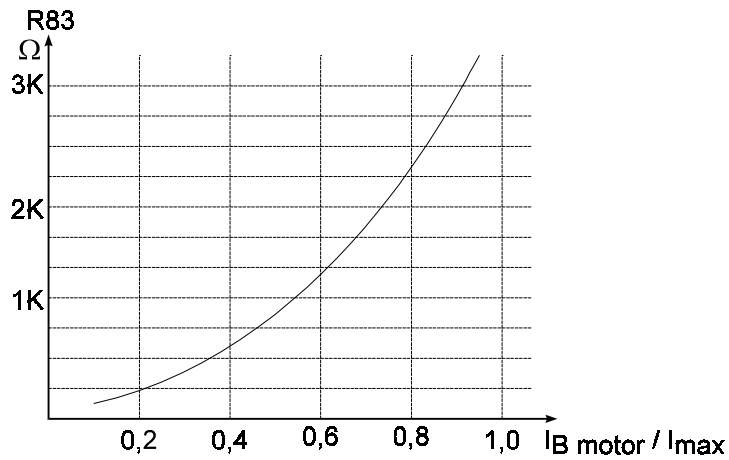

Fig. 2

Example: Motor M406D, $I_{\max} = 2 \times I_n = 11.2 \text{ A}$ in conj. with MSK 12, $I_{\max} = 17.7 \text{ A}$

$$\frac{I_{\text{motor}}}{I_{\text{ampl.}}} = \frac{11.2 \text{ A}}{17.7 \text{ A}} = 0.63 \quad \text{i.e. } R83 = 1.5 \text{ k}\Omega$$

5.4.3. RMS and peak current limitation with fixed resistors

Recommended servo module	Motor	$I_n \text{ rms}$ [A]	R87 [Ω]	$I_{\max \text{ rms}}$ [A]	R83 [Ω]
MSK 6	M 254B	2.8	390	5.6	1.3k
MSK 6	M 256B	4.3	-	8.6	-
MSK 12	M 404B	8.2	-	16.4	-
MSK 12	M 404C	4.8	270	9.6	1k
MSK 12	M 404D	2.8	68	5.6	430
MSK 12	M 406C	9.6	-	19.2	-
MSK 12	M 406D	5.6	390	11.2	1.5k
MSK 12	M 504E	9.4	-	18.8	-
MSK 12	M 504F	6.5	560	13.0	2k
MSK 12	M 506F	9.7	-	19.4	-
MSK 6	F 504	2.3	270	4.6	1k
MSK 6	F 634	3.2	560	6.4	2k
MSK 12	F 804	7.5	820	15.0	3k

Table 2

5.4.4. Components on the personality module

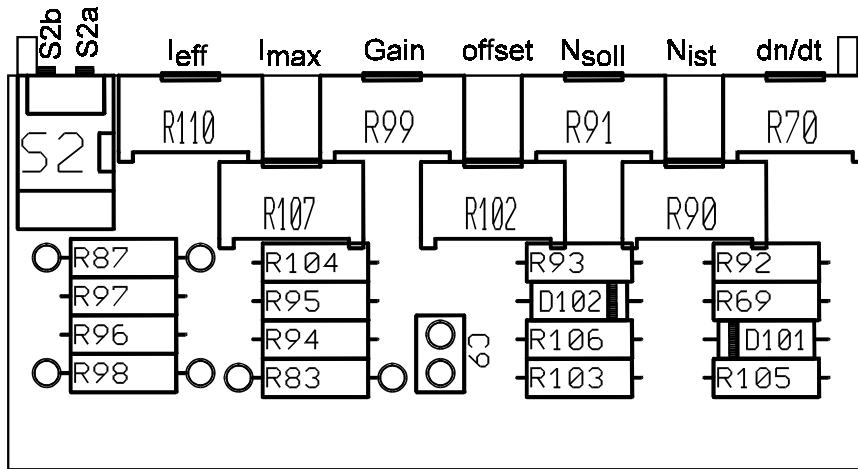

Fig. 3

5.4.5. Location of the personality module

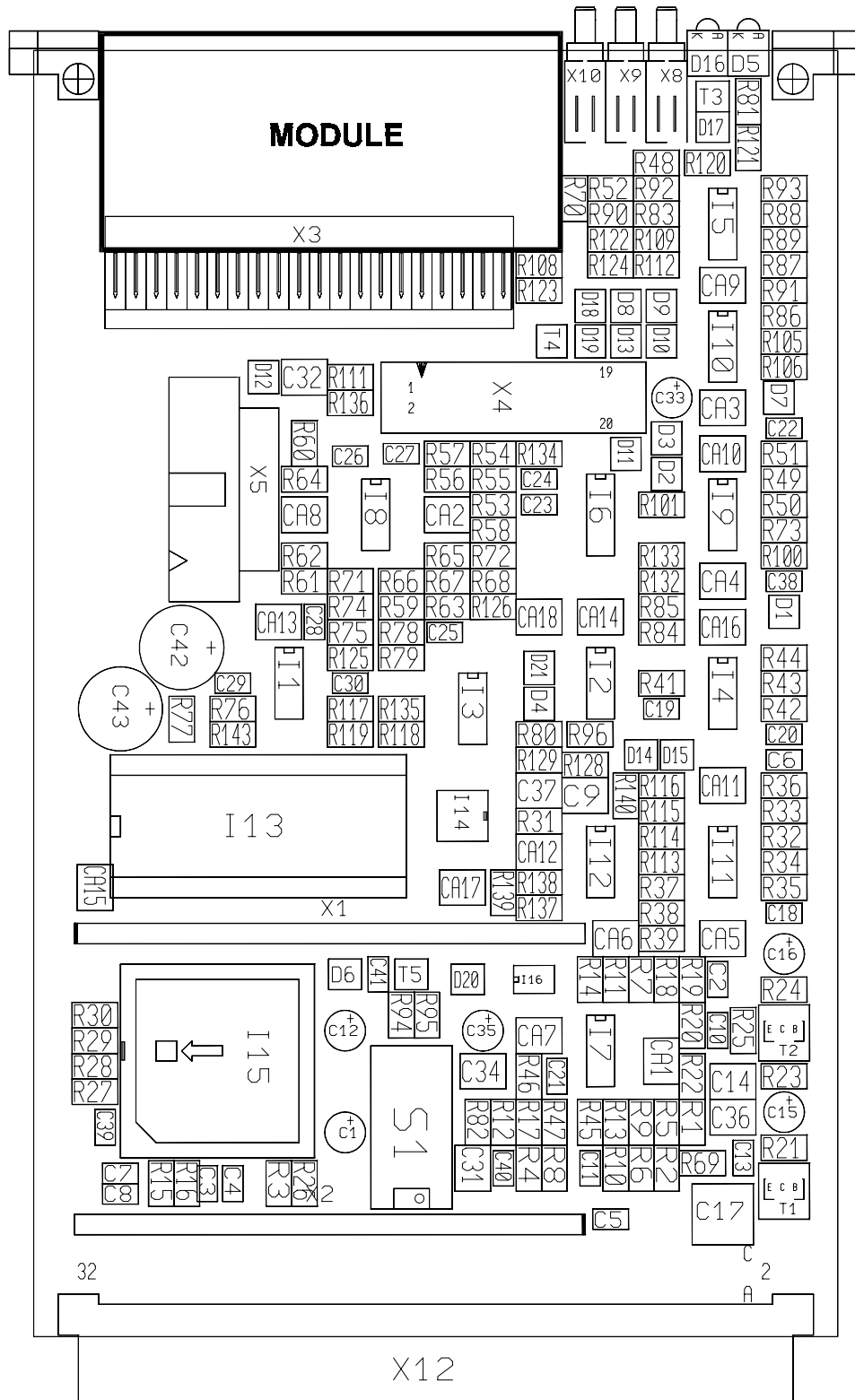

Fig. 4

5.5. Options

5.5.1. Encoder simulation "ES1"

Each module of the MSK series can be provided with this option (subsequent extension possible). The outputs are opto-isolated for better noise suppression and require an external power supply +5 V/50 mA. The output drivers (LS26C31) supply 5 V to RS 422. The encoder simulation generates two pulse trains shifted by 90° with max. 1024 counts per revolution. The index is gated. The index cannot be shifted electrically.

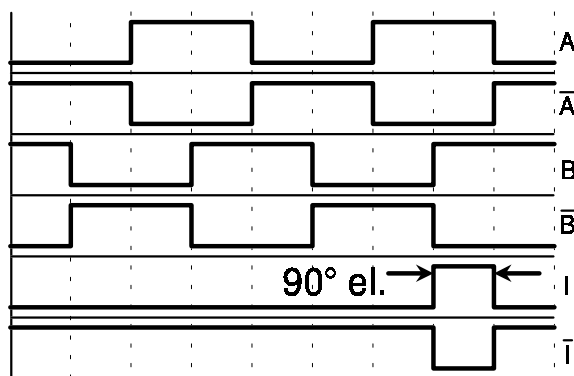

Fig. 6
Pulse diagram for CW rotation

Setting the resolution

Resolution	Switch 1	Switch 2
128	off	off
256	off	on
512	on	off
1,024 (Standard)	on	on

Table 3

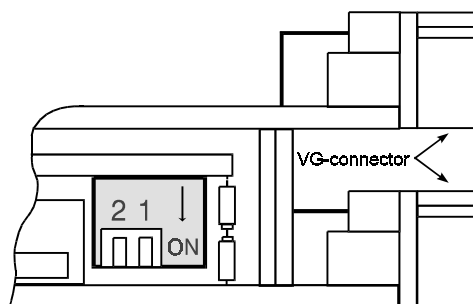

Fig. 7
Position of switches 1 and 2

5.5.2. Option "24 V external"

This option uses an external 24 V source to prevent loss of stored error messages in the servo module or of encoder signals in the event of an emergency shutdown or other fault condition. For this purpose a power relay has to be provided in the AC power supply ahead of the power supply module. Its function is to switch off the DC bus voltage in the case of a fault, in compliance with VDE regulations for emergency shutdown. It is also possible to use the 24 V voltage of a PLC as source. In this case the 24V supply is not isolated from U_z and PE.

5.5.3. Optional power supply "24 V external" with integrated power dump resistor

The standard power supply module can be fitted with the optional board "24 V external supply with integrated power dump resistor" (subsequent extension also possible). The AC power has to be connected at X6 on the motherboard of the power supply module. With a 3-phase supply it is possible to power 6 MSK modules with a reserve of 1 A for auxiliary circuits.

The integrated power dump resistor (40 Ω) is rated for 30 W/60 W without/with forced ventilation. For higher loads an external power dump resistor (8 Ω/100 W..500 W) has to be connected in parallel via connector X5 on the motherboard of the power supply module.

6. Trouble shooting

6.1. Fuses MSK 6/MSK 12

The fuses F1 and F2 can be replaced using suitable pliers. Please use the following fuse ratings:

	F1	F1 (OPT 24 V external)	F2
MSK 6	630 mA/mb	1.25 A/mb	8 A/sb
MSK 12	630 mA/mb	1.25 A/mb	16 A/sb

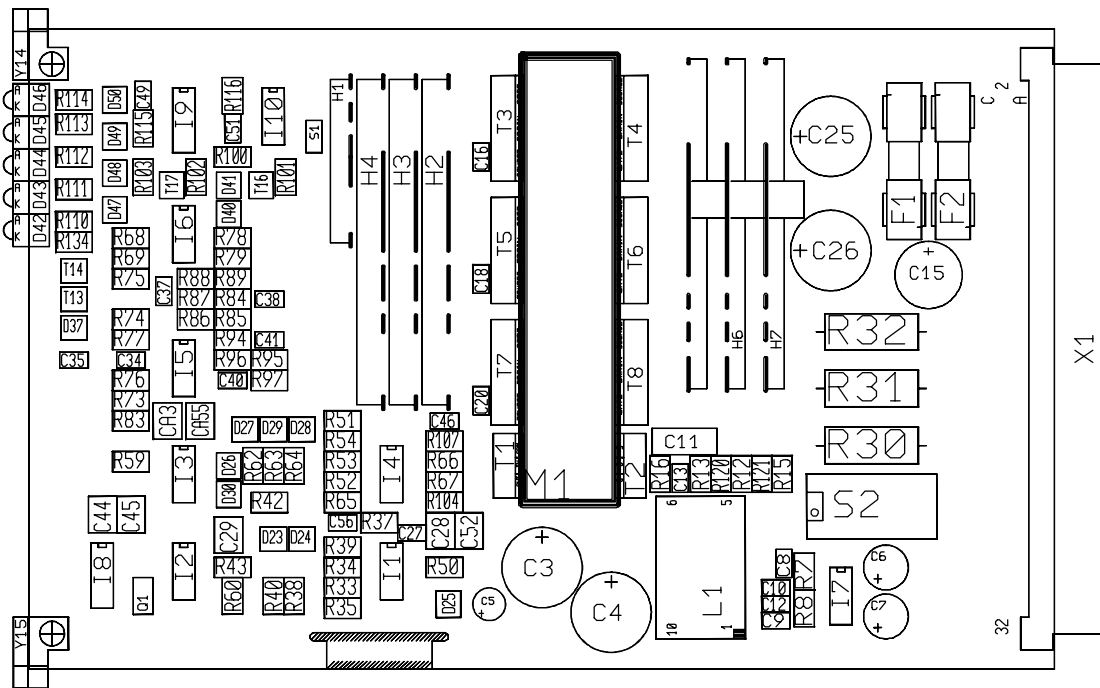

Fig. 8
Location of fuses on MSK

6.2. Fuses - MTB 25

To replace the fuses at the input of the power supply module and the fuses of the power dump resistor use suitable pliers.

Fuses at the input of the power supply unit F1, F2, F3 = 16 A/sb
 Power dump resistor F4 = 8 A/sb

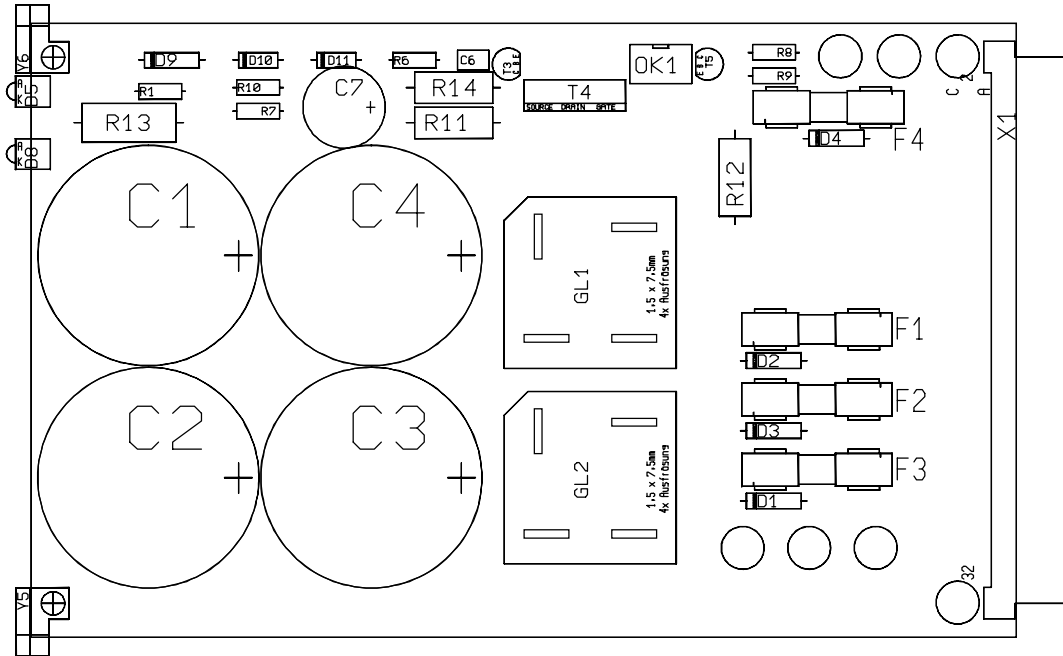

Fig. 9
 Location of fuses on MTB 25

6.2.1. Fuses - optional power supply

The fuses for the auxiliary voltage supply can be replaced using suitable pliers.
 Rating of fuses F1, F2, F3 = 4 A/sb

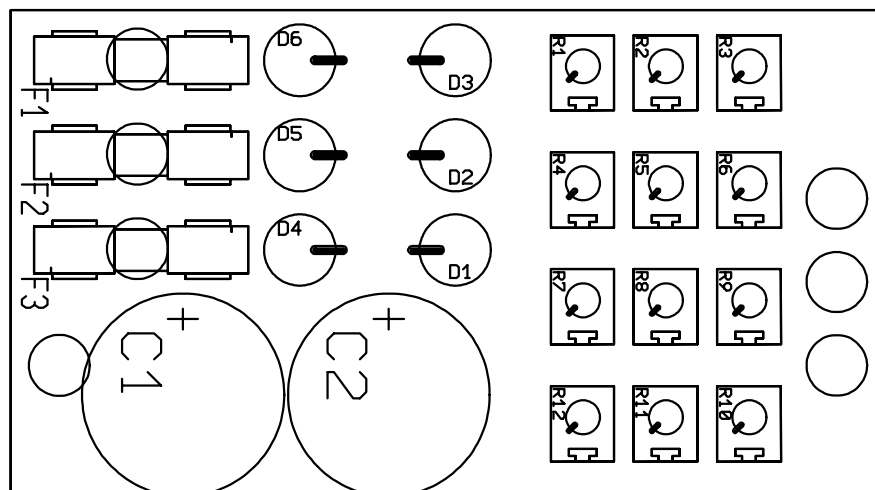

Fig. 10

Components on the 24 Vext option with integrated power dump resistors - location of fuses

6.3. Trouble shooting table

Problems during set-up are mostly due to incorrect wiring or false settings of the modules. The table on page 23 contains a summary of various problem symptoms and their possible causes.

Most faults can be remedied by the user, observing the drive and state of the LEDs.

Trouble shooting table:

Symptom	Power supply module		Servo module							Refer to no.
	U _Z	Power dump	LIM	I ² × t	Over-temp.	Over-curr.	±15V	Over-volt.	Under-volt.	
The motor does not run	○	○	○	○	○	○	○	○	○	1
	☀	○	○	○	○	○	○	○	○	2,3
	☀	○	○	○	○	○	○	○	☀	3
	☀	○	☀	○	○	○	○	○	○	5
	☀	○	○	○	☀	○	○	○	○	6
	☀	○	○	○	○	☀	○	○	○	7
	☀	○	○	○	○	○	☀	○	○	8
	☀	○	○	○	○	○	○	☀	○	9
	☀	☀	○	○	○	○	○	○	○	10
Rated speed is not reached	☀	○	○	○	○	○	○	○	○	11
	☀	○	○	☀	○	○	○	○	○	12
Motor speed oscillates	☀	○	○	○	○	○	○	○	○	13
Motor speed is too low	☀	○	○	○	○	○	○	○	○	14
Motor speed is too high	☀	○	○	○	○	○	○	○	○	15
Motor accelerates / decelerates too fast or too slow	☀	○	○	○	○	○	○	○	○	16
Zero speed of motor is not possible	☀	○	○	○	○	○	○	○	○	17

Table 4

Explanation ☀ LED on ○ LED off

If something goes wrong:

1.
 - a) No voltage ($3 \times 85 V_{\text{rms}}$) on the power supply module.
Remedy: Check the connection.
 - b) Defective power supply module and/or blown fuses.
Remedy: Check the fuses and/or replace the power supply module.
2.
 - a) No bus connection between the motherboard of the power supply module and the motherboard of the servo module.
Remedy: Connect using suitable cables (2.5 mm^2).
 - b) Blown fuse F1 of the servo module or no auxiliary voltage on the "24 V external" option.
Remedy: Check the fuse and/or restore the auxiliary voltage.
3.
 - a) Blown fuse F2 of the servo module or no voltage ($3 \times 85 \text{ V}$) between the "24 V external" option and the power supply module.
Remedy: Check the fuse and/or restore the voltages.
4.
 - a) "Enable" input is not connected.
Remedy: Make the minimal connections to get the drive running (see page 28).
 - b) Defective servo module.
Remedy: Change the servo module.
5.
 - a) LED "LIM" is on. A limit switch has been hit, or both enable inputs for the limit switch are not connected.
Remedy: Move the axis from the limit switch with an inverted velocity command, or connect the "Enable forward" or "Enable reverse" input at the front connector X5.
6.
 - a) The servo module is overheated.
Remedy: Allow the servo module to cool down, use forced ventilation or reduce the ambient temperature as required.
 - b) The thermo switch of the motor was tripped due to an incorrectly sized motor and/or resolver connection, or the torque drawn from the motor was too high for a longer time.
Remedy: Check motor and resolver cable.
Check whether the motor has been sized properly, check motor environment (temperature, flange cooling).
 - c) The motor has no thermo switch or the thermo switch is not connected.
Remedy: Connect the thermo switch to pin 1 and 2 of connector X9 or bridge the connection. In the absence of a thermo switch the motor has to be protected by the RMS current limitation in the servo module (see page 14 and 15).
7.
 - a) External short-circuit between the motor phases.
Remedy: Check for a short-circuit in the motor cable and make sure that the resistance between the phases has the same value.
 - b) Short circuit phase to ground
Remedy: Check the motor phases/motor cable for a short circuit phase to ground and/or check the motor connector and replace it if necessary.
8.
 - a) LED " $\pm 15 \text{ V}$ " is on. One of the auxiliary voltages is $< 14 \text{ V}$.
Remedy: The auxiliary voltage output at connector X6 draws more than 10 mA or the servo module is defective. Replace the servo module.

9. LED "Überspg." (over-voltage) is on.
- AC power is higher than $3 \times 95 V_{rms}$
Remedy: Check AC power input; use only the recommended transformers.
 - No power dump resistor.
Remedy: Connect the power dump resistor as shown in the Appendix - see page 27, 28 and 34. (Not applicable for the option "24 V external with integrated power dump resistor").
 - Multi-axis operation: All axes had to stop at the same time (e.g. emergency stop).
The resistance of the power dump resistor may be too high.
Remedy: Use resistors of $R_{min} = 8 \Omega$ or an additional external resistor connected in parallel to the integrated power dump resistor.
 - Blown power dump fuse.
Remedy: Check the fuse F4 8 A/sb and replace if necessary. (See page 21 Location of fuses on power supply module).
10. LED "Ballast" is on.
- Without a power dump resistor the "Ballast" LED may flicker. This does not indicate an incorrect function.
 - With a connected power dump resistor the LED flickers when the axis is braked. The energy in the power dump resistor is converted into heat. This is a correct function.
 - With a connected power dump resistor the LED is permanently illuminated.
Remedy: Defective power supply module. Replace the unit.
11. The drive does not reach the rated speed.
- No velocity command signal, or its gain is too low.
Remedy: Turn the potentiometer "N_{soil}" CW or connect the velocity command signal to X5 on the front panel.
 - The voltage constant of the respective motor is too high, or the bus voltage drops to a value that is too low, especially with a single-phase line voltage.
Remedy: Check the voltage requirements of the motor and the AC power supply.
 - The potentiometer "I_{max}" is not turned fully CW or the external current limitation is active.
Remedy: Turn the potentiometer "I_{max}" up or increase the current limit.
12. The drive does not reach its rated speed and the LED " $I^2 \times t$ " is on.
- The requested torque is higher than the nominal torque of the motor or the potentiometer "I_{rms}" is not turned fully CW.
Remedy: Check the torque of the load and the friction torques of the equipment and compare against the motor/controller data.
 - Reversed supply leads of the motor and/or resolver.
Remedy: Check the connection against the wiring diagram on page 29.
 - The servo module limited the peak current because the RMS torque of the motor was exceeded at high speeds.
Remedy: Reduce the torque of the load or use a servo module and motor with a higher output power.
13. The motor speed oscillates.
- The "Gain" potentiometer is set too high.
Remedy: Turn the potentiometer back CCW until the tachometer does not show any oscillation.
 - Even in the fully CCW position of the "Gain" potentiometer the motor still oscillates.
Remedy: Reduce the value of R98 to 68 k Ω and increase C9 to 330 nF on the personality module (see page 16).

- c) The motor still oscillates after carrying out b).
Remedy: Check the mechanical connection of your machine with the motor, especially the coupling. The coupling should be stiff against torsional forces. Elastic power transmission elements such as belts and rubber couplings should be avoided where possible.
- d) The existing gears or couplings show backlash.
Remedy: Use gears and couplings with minimum backlash.
- 14.** The motor speed is too slow.
- a) The potentiometer "N_{soil}" is not turned fully CW.
Remedy: Turn the potentiometer CW until reaching "N_{soil}".
- b) The potentiometer "N_{ist}" is turned fully CCW.
Remedy: First turn the potentiometer "N_{soil}" to the fully CW position and then turn the potentiometer "N_{ist}" CW until reaching "N_{soil}".
- c) The voltage at the velocity command input is too low.
Remedy: The velocity command input voltage should be 8 - 10 V for the maximum speed in order to increase the signal-to-noise ratio.
- 15.** The motor speed is too high.
- a) The sum of both velocity command inputs is too high.
Remedy: Reduce the voltage on both inputs.
- b) The potentiometer "N_{soil}" is turned fully CW.
Remedy: Turn the potentiometer "N_{soil}" CCW. If the setting range is too large towards slower speeds, increase R94 (nom = 20 k Ω) on the personality module to 47 k Ω (see page 16).
- 16.** The motor accelerates/decelerates either too fast or too slow.
Remedy: Set the ramp using the "dn/dt" potentiometer. Fully CCW position corresponds to minimum, fully CW position corresponds to maximum acceleration/deceleration of the motor.
Note: The "dn/dt" potentiometer acts only on velocity command input 1!
- 17.** Zero speed of the motor is not possible.
- a) One or both of the velocity command signals has offset.
Remedy: Feed both velocity command signals from SPS to servo module differentially. Velocity command inputs not being used should be short-circuited.
- b) The offset potentiometer is not set.
Remedy: Adjust the offset potentiometer. If zero speed cannot be obtained, refer to a). It may be necessary to shield the velocity command lead. The maximum common-mode range is ± 10 V.

7. Connection diagrams

7.1. Connection diagram - MTB-25

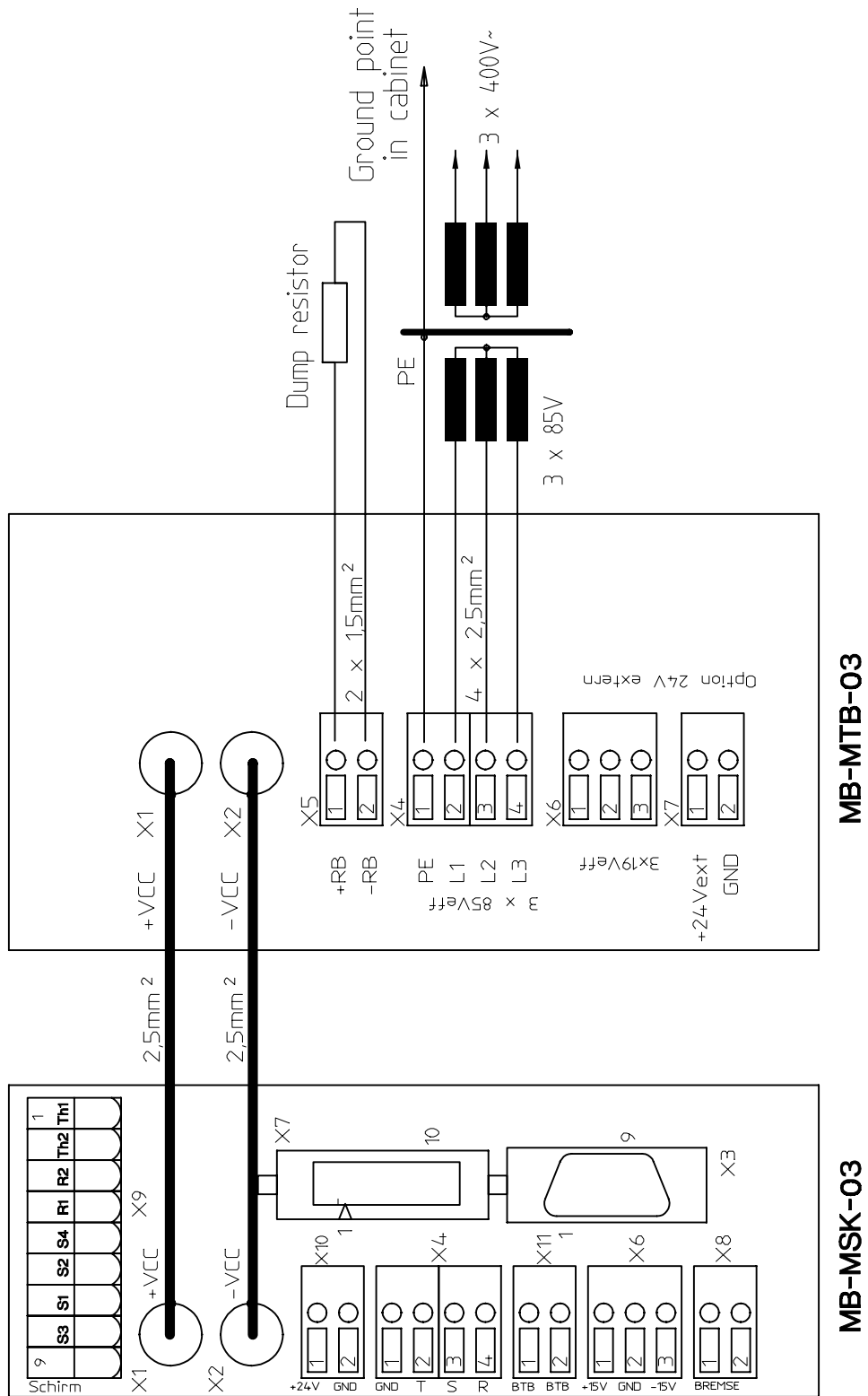

Fig. 11

7.2. Connection diagram - MTB-25/MSK 6/MSK 12 with option "24V external"

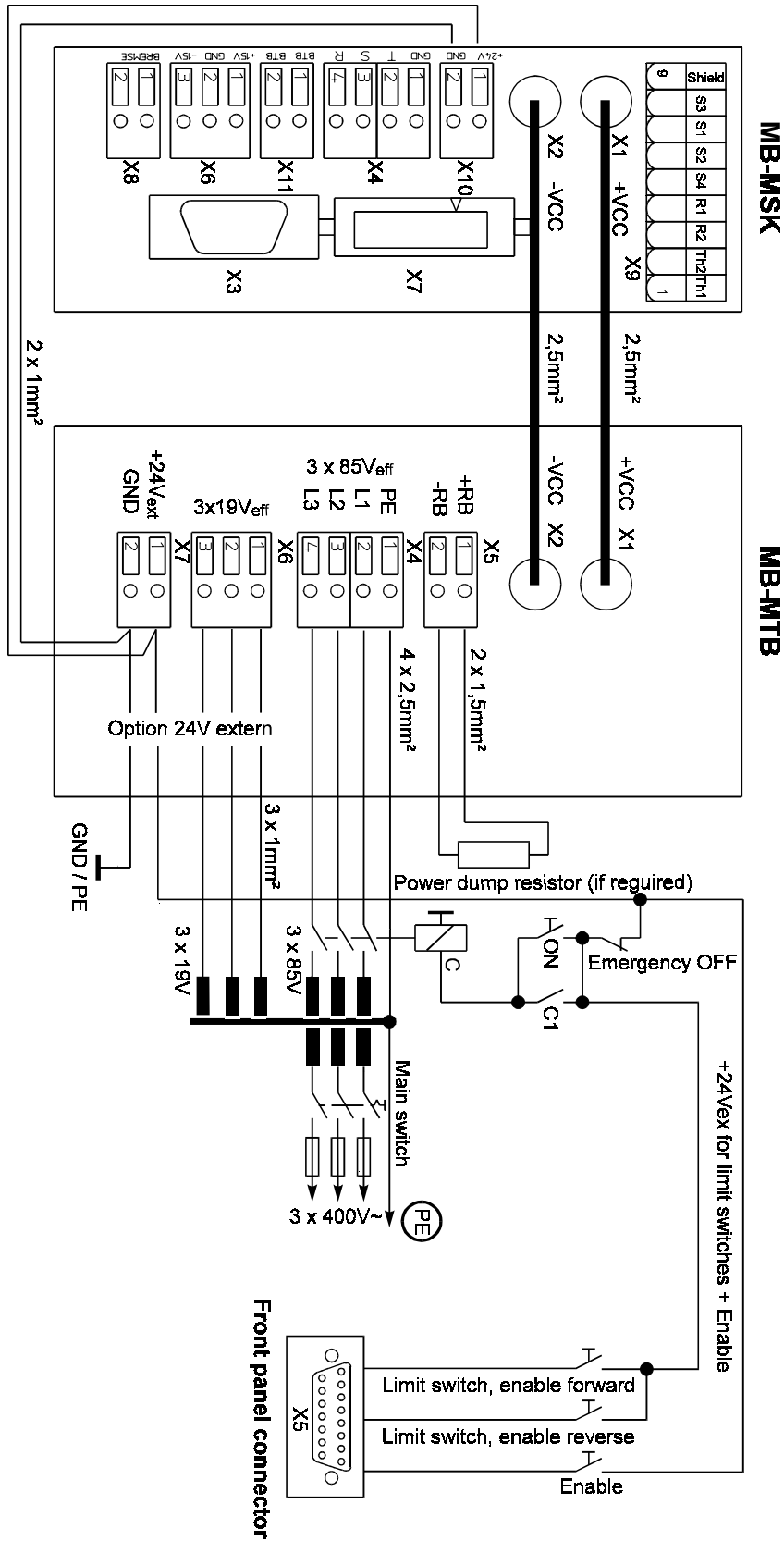

Fig. 12

7.3. Connection diagram MSK 6/MSK 12 with motors M254-M506 and F504-F804

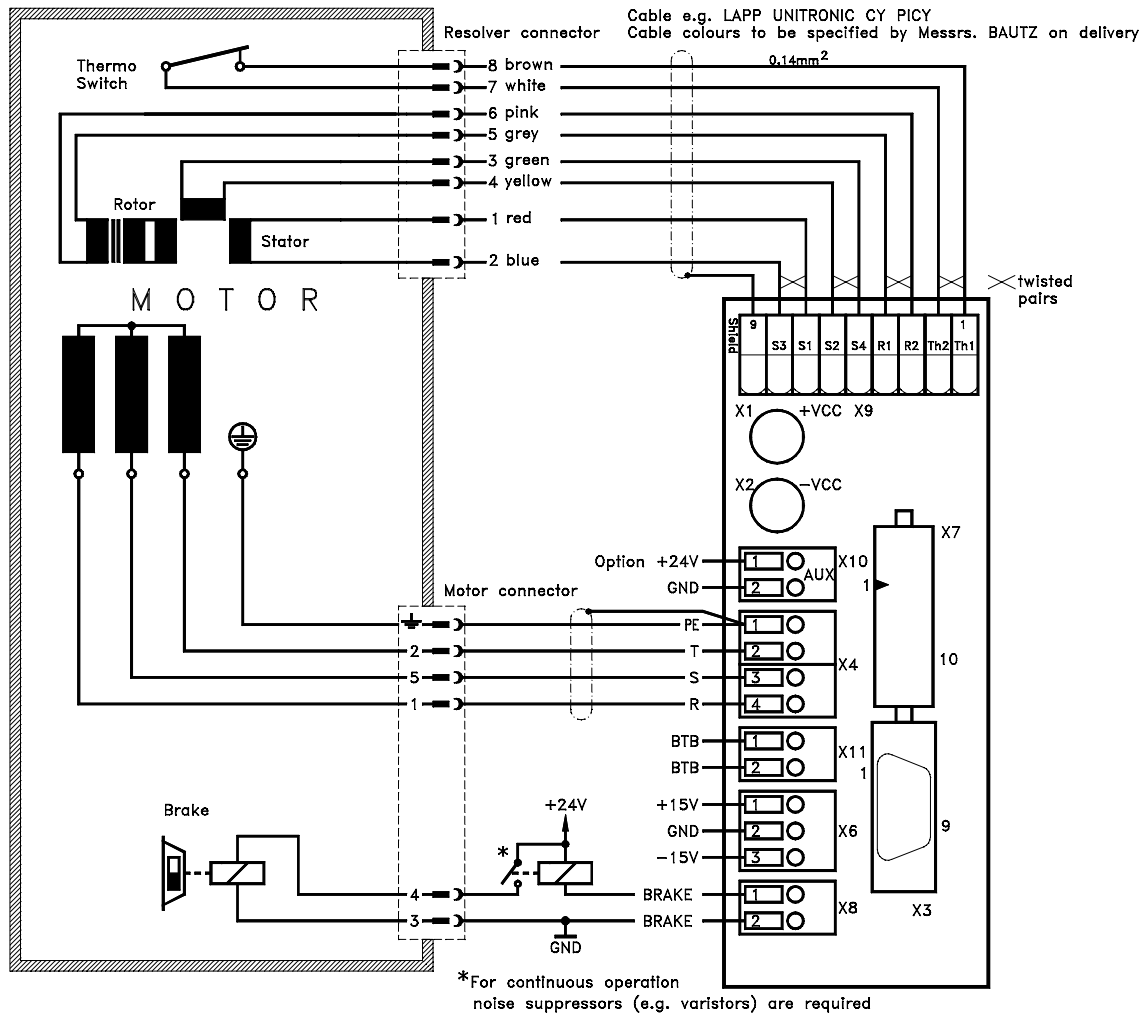

Fig. 13

M 254B-0	M 404B-0	M 504E-0	F 504D-0	F 634F-0	F 804F-0
M 254B-B	M 404B-B	M 504E-B	F 504D-B	F 634F-B	F 804F-B
M 256B-0	M 404C-0	M 504F-0			
M 256B-B	M 404C-B	M 504F-B			
	M 404D-0	M 506F-0			
	M 404D-B	M 506F-B			
	M 406C-0				
	M 406C-B				
	M 406D-0				
	M 404D-B				

0 = without brake
B = with brake

7.4. Front panel - MSK 6 / MSK 12 and MTB 25

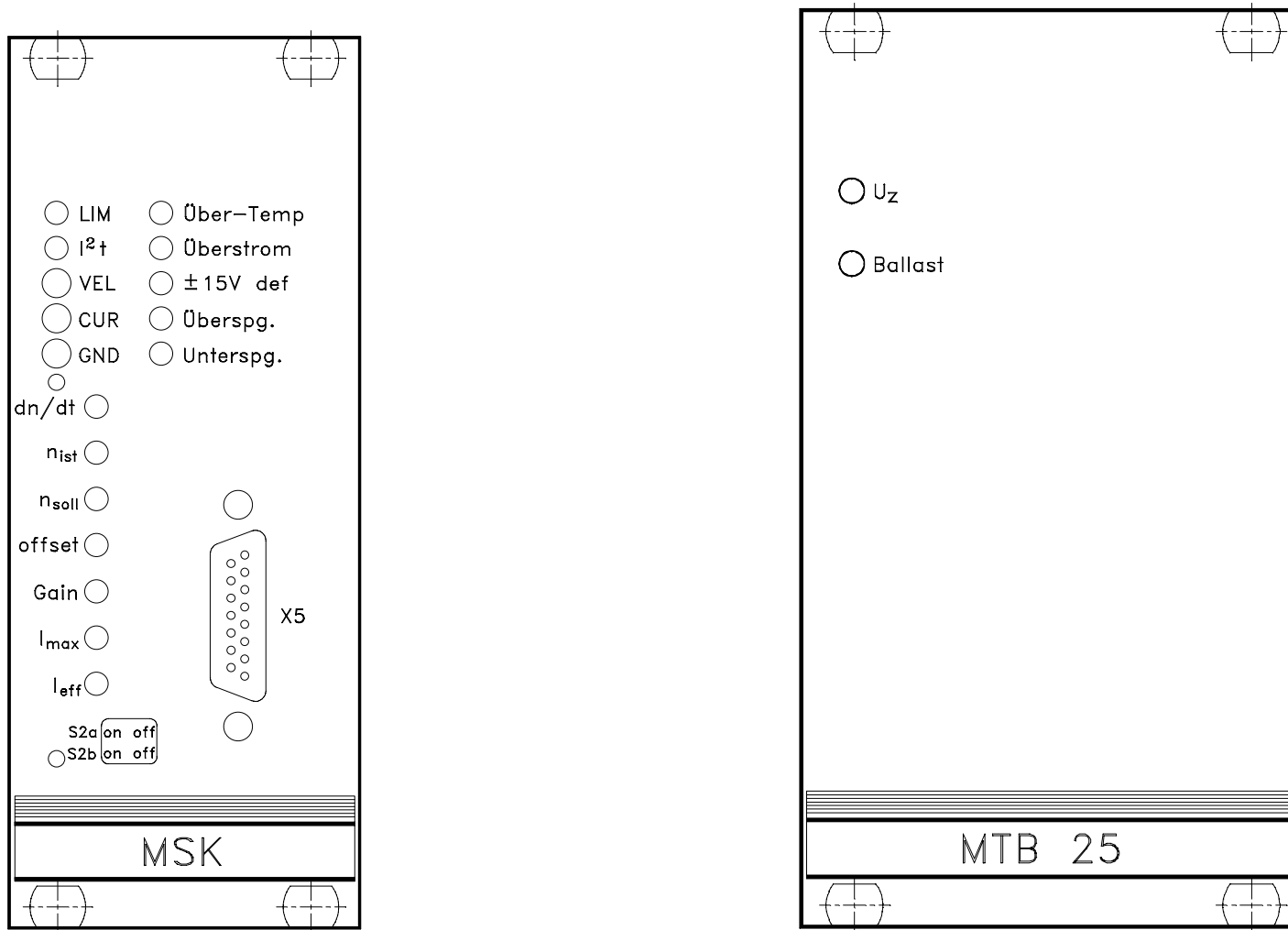

Fig. 14

7.5. Dimensions

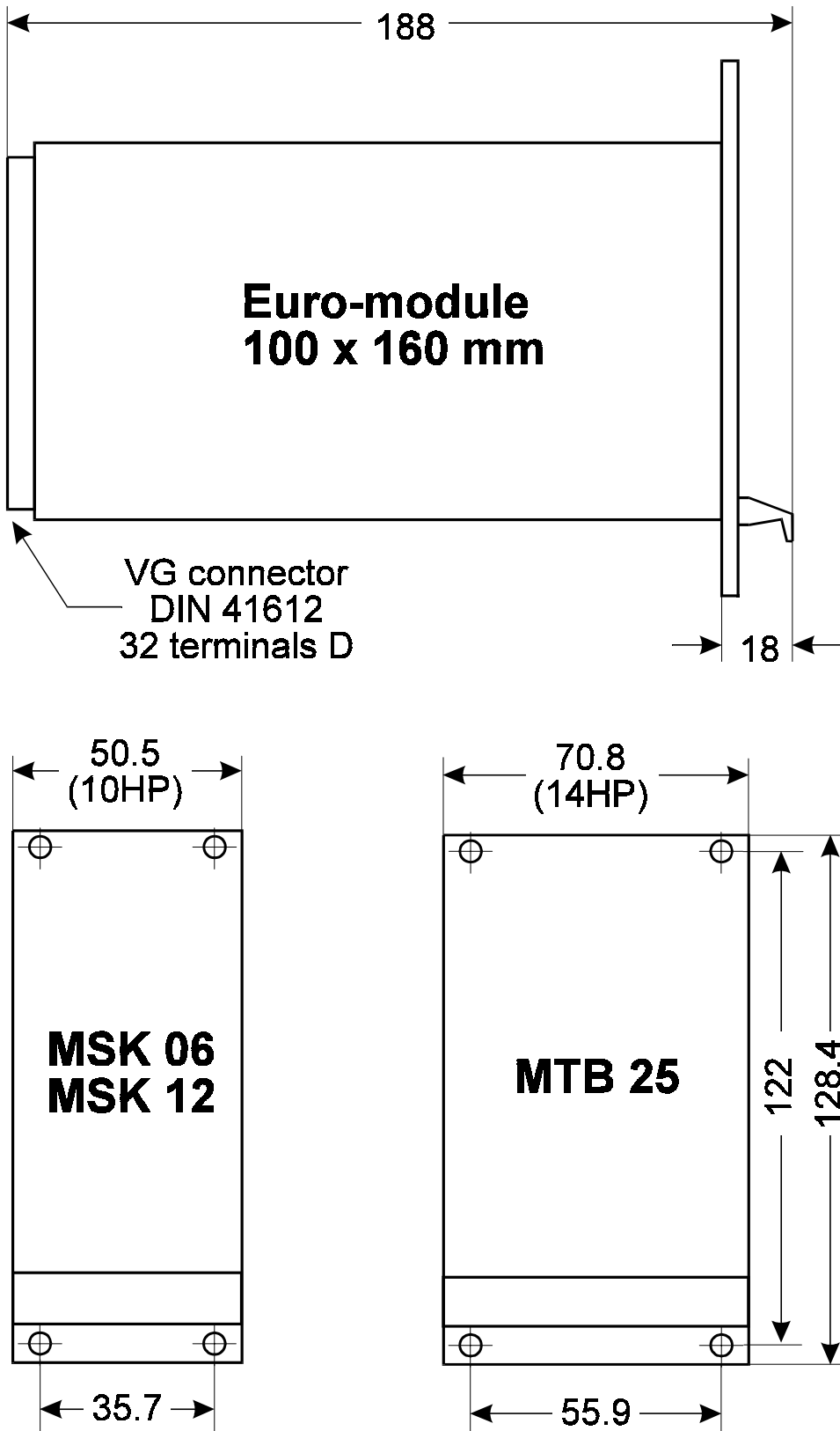
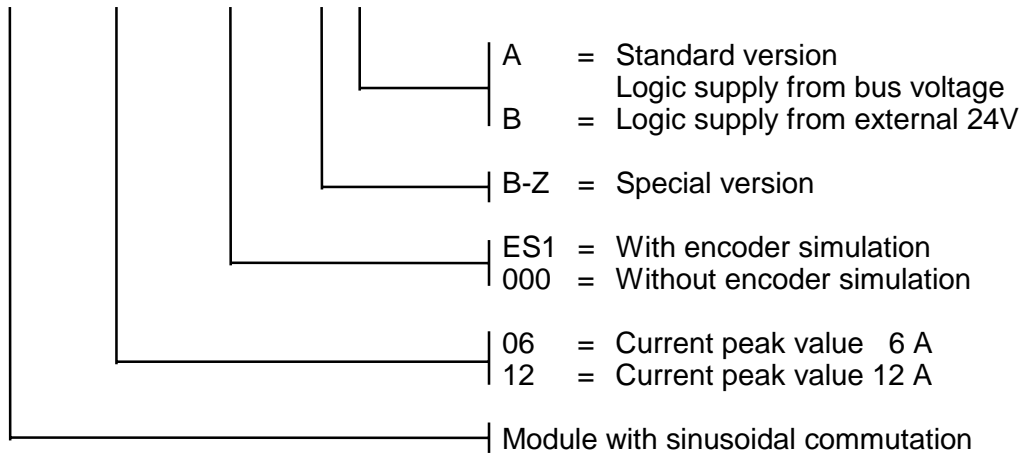

Fig. 15

8. Ordering details

8.1. Order code for MSK, MTB and motherboards

MSK 12-ES1-AA



MTB-25-85-012-AB

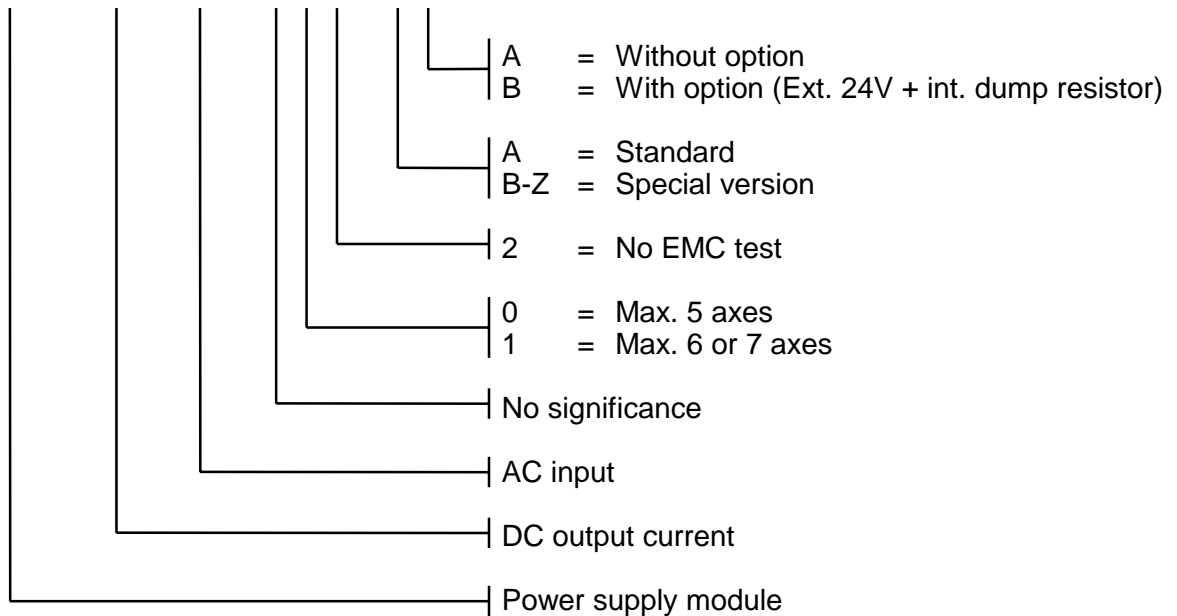

Motherboard - type: MB-MSK
type: MB-MTB

8.2. Order code for power dump resistors

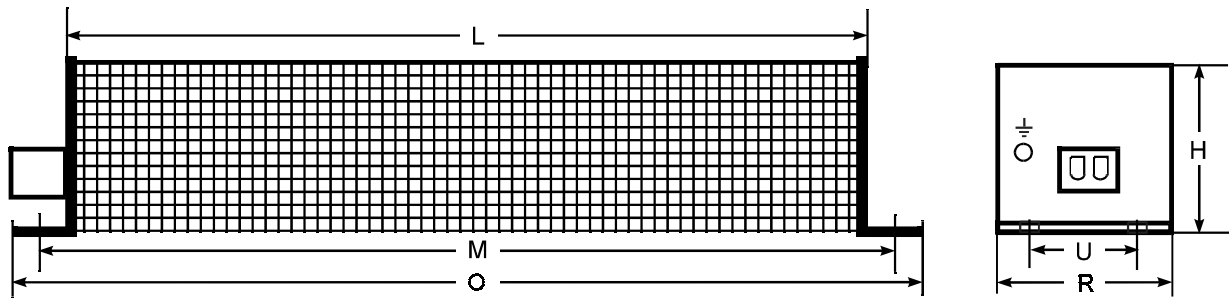

Order code	H	L	M	O	R	U
09 RK	86 mm	308 mm	324 mm	324 mm	75 mm	48 mm

8.3. Order code for rack system

RSK 3-21-42

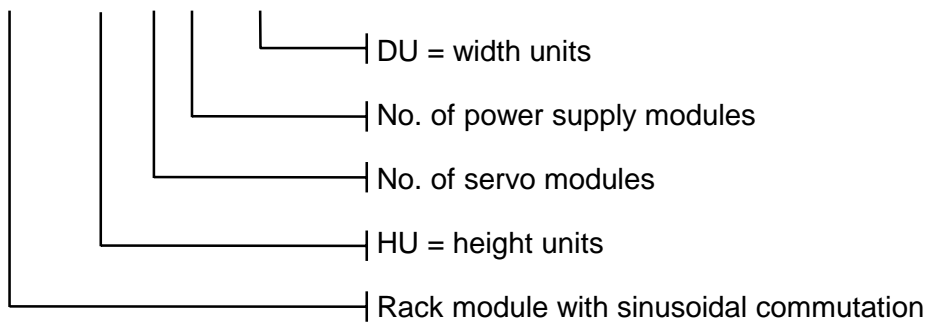

9. Appendix

9.1. Transformer dimensions and order code

Single-phase transformer to VDE 0550

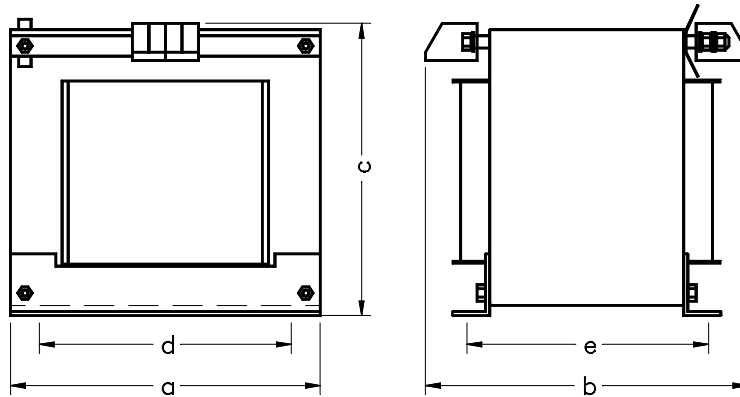

Order code	Power	a	b	c	d	e
TO 65.1	0,5 kVA	120	130	106	90	102
TO 66.1	1,0 kVA	150	165	142	122	127

Three-phase transformers to VDE 0550

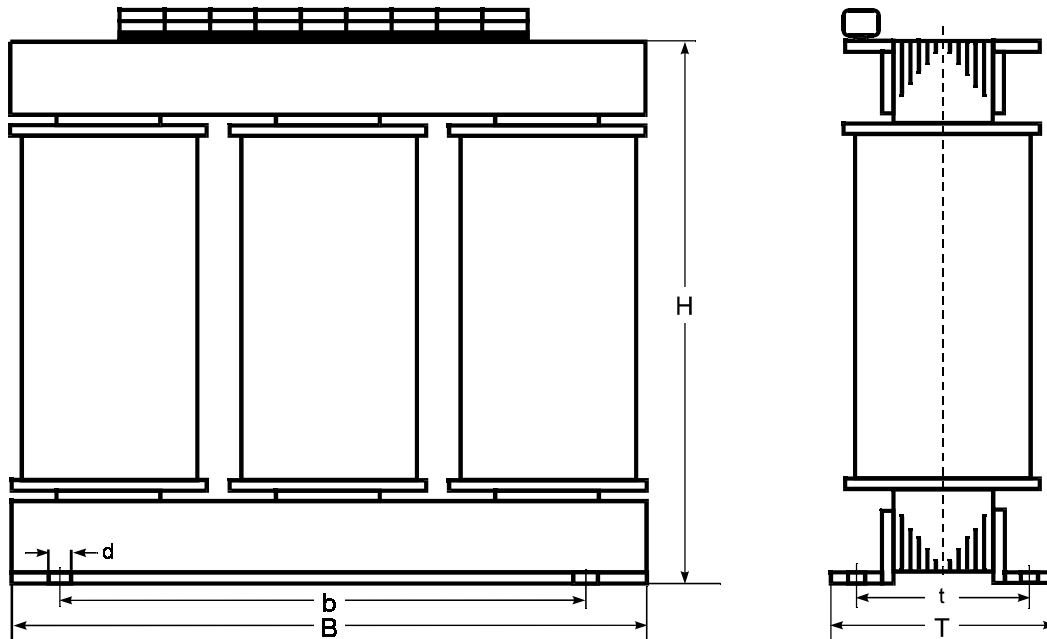

Order code	Power	D	T	H	b	t
TO 118.1	1,0 kVA	240	121	210	190	96
TO 119	2,3 kVA	265	152	230	215	127

9.2. Motor cables

Type: KAB-MO motor cable (without a brake), shielded, $4 \times 1.5 \text{ mm}^2$, $\varnothing 10.9 \text{ mm}$
 Type: KAB-MO-B motor cable (with a brake), shielded, $7 \times 1.5 \text{ mm}^2$, $\varnothing 13.9 \text{ mm}$

9.3. Resolver cable

Type: KAB-RES resolver cable, double shielded, $4 \times 2 \times 0.25 \text{ mm}^2$, $\varnothing 11.5 \text{ mm}$