

привод оси X

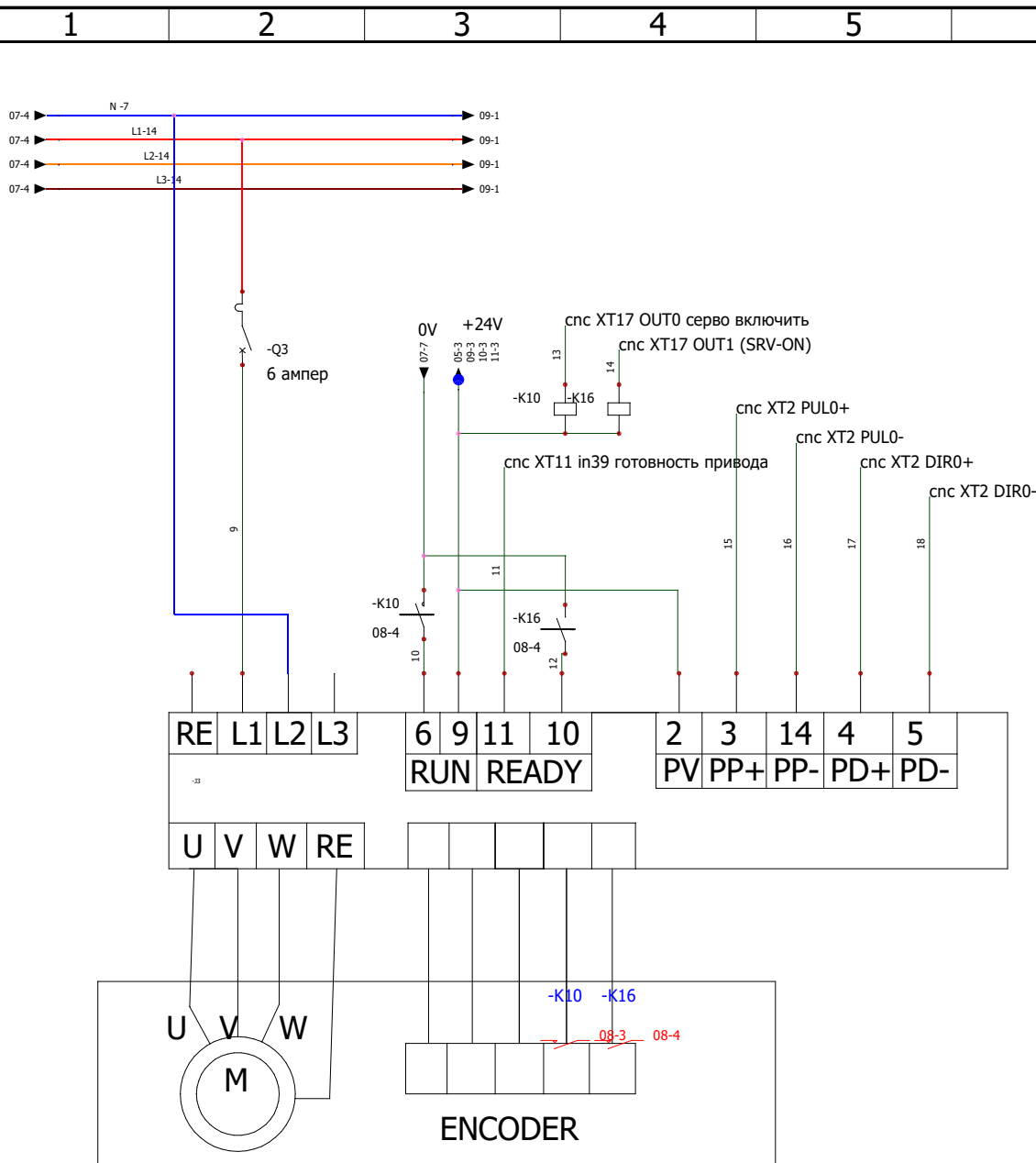

Пакет документов

				REVISION
				0
0	31.12.2021	Михаил		
REV.	DATE	NAME	CHANGES	SCHEME
				08
User data 1			User data 2	

CONTRACT:

LOCATION:

+L1

Главный электрошкаф