

Table of Contents

I.	Introduction.....	1
II.	Safety Precautions.....	2
III.	Storage and Installation.....	4
IV.	Standards and Specifications.....	5
V.	Wiring.....	8
VI.	Instruction of the Digital Operator.....	14
VII.	Commissioning.....	19
VIII.	Function List.....	20
IX.	Descriptions of Functions.....	27
X.	Care & Maintenance, Fault Information and Troubleshooting..	66
XI.	Selection of Peripheral Devices and Disposition.....	72
XII.	Appendices.....	76

This Instruction Manual is subject to changes due to product upgrading. No further notice will be given.

I. Introduction

Thank you for purchasing and using the RLP series multi-function and high performance inverter.

Please read carefully the operation manual before putting the inverter to use, so as to correctly install and operate the inverter, give full play to its functions and ensure the safety. Please keep the operation manual handy for future reference, maintenance, inspection and repair.

In case of any problems that can not be solved during your use of our product, please contact our local distributors at any time or contact with our company directly. Since the inverter is a kind of electrical and electronic product, it must be installed, tested and adjusted with parameters by specialized engineering persons of motors. The marks of



and other symbols in the manual remind you of the safety and prevention cautions during the handling, installation, running and inspection. Please follow these instructions to make sure the safe use of the inverter. In case of any doubt, please contact our local agent for consultation. Our professional persons are willing and ready to serve you.

The manual is subject to change without notice.

II. Safety Precautions

The RLP series multi-function and high performance inverter has been strictly and well packed before ex-work. After your purchase, please examine the product package to see whether any components are lost during the transportation, and whether the product specifications and models comply with the machine you purchased before the unpacking. Contact the supplier in case of any problem.

2.1 Examination after unpacking

1. The machine is provided with an instruction manual and a warranty card.
2. Examine the nameplate on the inverter side to confirm it is the product you purchased.

2.2 Safety precautions

 Danger indicates wrong use may kill or injure people.

 Caution indicates wrong use may damage the inverter or mechanical system.

Note: The grades of caution will probably lead to severe results due to different conditions. Please follow the notes, as they are very important for personal safety.

 Danger

- Be sure to turn off the input power supply before wiring.
- Do not touch any internal electrical circuit or component when the charging lamp is still on after the AC power supply is disconnected, which means the inverter still has high voltage inside and it is very dangerous.
- Do not check components and signals on the circuit boards during the operation.
- Do not disassemble or modify any internal connecting cord, wiring or component of the inverter by yourself.
- Do not operate the switch button with wet hand, so as to prevent electrical shock.
- Be sure to make correct ground connection of the earth terminal of the inverter.
- Never remodel it or exchange control boards and components by yourself. It may expose you to an electrical shock or explosion, etc.



Caution

- Do not make any voltage-withstanding test with any component inside the inverter. These semi-conductor parts are subject to the damage of high voltage.
- Never connect the AC main circuit power supply to the output terminals U.V W of the inverter.
- The inverter and the braking resistor are under high temperature when the power supply is connected or soon after it is disconnected, do not touch them, so as to prevent burning.
- Voltage imposed on all terminals should conform to the voltage indicated in the instruction manual, so as to prevent explosion or damage.
- The main electric circuit boards of CMOS and IC of the inverter are subject to the effect and damage of static electricity. Don't touch the main circuit boards.
- Installation, testing and maintenance must be performed by qualified professional personnel.
- The inverter should be discarded as industrial waste. It is forbidden to burn it.
- Please examine and commission the inverter prior to use if it is saved for long time.
- Setting for high speed operation of the inverter can be made easily. Before the setting is changed, examine whether the motor and its mechanical performances are suitable for high speed running.

2.3 Precautions during transportation and storage



Caution

- Do not carry the front cover of the inverter directly when handling. It should be handled with the base to prevent the fall-off of the front cover and avoid the dropping of the inverter, which may possibly cause the injuries to people and the damages to the inverter.
- Mount the inverter on a metal or other noncombustible material to avoid the risk of fire.
- Install the inverter in a safe location, avoiding high temperature, direct sunlight, humid air or water.
- Keep the inverter from the reach of children or persons not concerned.
- The inverter can only be used at the places accredited by our company. Any unauthorized working environment may have the risks of fire, gas explosion, electric shock and other incidents.
- Install a heat sink or other cooling device when installing more than one inverter in the same enclosure, so that the temperature inside the enclosure be kept below 40°C to avoid overheat or the risk of fire.
- Be sure to turn off the power supply before disassembling or assembling the operation key panel and fixing the front cover to avoid bad contact causing faults or non-display of the operator.
- Do not install the inverter in a space with explosive gas to avoid the risk of explosion.
- If the inverter is used at or above 1,000m above seal level, the cooling efficiency will be worse, so please run it by de-rating.
- Do not install any contactor and other components of capacitor or varistor on the output side of the inverter. Otherwise it will cause malfunctions and damages of components of the inverter.
- Do not install any switch component like air circuit breaker or contactor at the output of the inverter. If any of such components must be installed because of the

requirements of process and others, it must be ensured that the inverter has no output when the switch acts. In addition, it is forbidden to install any capacitor for improvement of power factor, or any varistor against thunder at the output. Otherwise it will cause malfunctions, tripping protection and damages of components of the inverter. Please remove them as shown in the below diagram.

- It will affect the service life of the inverter if a contact is connected to the front end of input of the inverter to control its starts and stops. Generally it is required to control it through FOR or REV terminals. Special attention should be paid to its use in the case of frequent starts and stops.
- Please use an independent power supply for the inverter. Do avoid using the common power supply with an electrical welder and other equipment with strong disturbance. Otherwise it will cause the protection or even damage of the inverter.

Before the Power-up

- Check to make sure that the voltage of the main circuit AC power supply matches the input voltage of the inverter.

The symbol  represents ground terminals. Be sure to make correct ground connection of the earth terminals of the motor and the inverter for safety.

- No contactor should be installed between the power supply and the inverter to be used for starting or stopping of the inverter. Otherwise it will affect the service life of the inverter.

During the Power-up

- Do not plug the connectors of the inverter during the power up to avoid any surge into the main control board due to plugging, which might cause the damage of the inverter. Always have the protective cover in place before the power up to avoid electrical shock injury.

During the Operation

- Never connect or disconnect the motor set while the inverter is in running. Otherwise it will cause over-current trip and even burn up the main circuit of the inverter.
- Never remove the front cover of the inverter while the inverter is powered up to avoid any injury of electric shock.
- Do not come close to the machine when the fault restart function is used to avoid anything unexpected. The motor may automatically restart after its stop.
- The function of STOP Switch is only valid after setting, which is different from the use of emergent stop switch. Please pay attention to it when using it.

III. Storage and Installation

1. Storage

- It must be stored in a dry place without rubbish or dust.
- The suitable temperature for storage is between -20°C and $+65^{\circ}\text{C}$.
- The relative humidity required is 0-95% without condensation.
- There is no corrosive gas or liquid in the storage ambience.
- It's better to lay the inverter on a rack and keep it in a proper package.
- It is better not to store the inverter for long time. Long time storage of the inverter will lead to the deterioration of electrolytic capacity. If it needs to be stored for a long time, make sure to power it up one time within a year and the power-up time should be at least five hours. When powered up, the voltage must be increased slowly with a voltage regulator to the rated voltage value.

2. Installation Site and Environment

- Ambient temperature -5°C to 40°C with good ventilation.
- Free from the interference of electromagnetic noise.
- No water drop, stream, dust, cotton, and metallic particles.
- Free from oil, salt or corrosive gas.
- Free from vibration.
- Free from high temperature and large humidity, no rainfall, humidity <90% (no condensation).
- Prohibited from use in inflammable, humid and explosive liquid or solid places.
Attention: The ambient conditions of the inverter will affect its service life.

3. Installation Space and Direction

- There must be enough space left around the inverter for easy maintenance and cooling. See Diagram.
- The inverter must be installed vertically with the smooth ventilation for effective cooling.
- If there is any instability when installing the inverter, please put a flat board under the inverter bottom base and install it again. If the inverter is installed on a loose surface, stress may cause damage of parts in the main circuit, so as to damage the inverter.
- The inverter should be installed on non-combustible materials, such as iron plate.
- If several inverters are installed, upper and lower, together in one cabinet, please add heat dissipation plates and leave enough space between the inverters.

IV. Standards and Specifications

1. Specifications

Type	Input Voltage	Power (KW)	Inverter Capacity (KVA)	Output Current (A)	Suitable (Motor)
RLPM10 00D423A	One & Three Phase 220V 50Hz	0.4	1.0	2.5	0.4
RLPM10 00D7523A	One & Three Phase 220V 50Hz	0.75	2.0	5.0	0.75
RLPM10 01D523A	One & Three Phase 220V 50Hz	1.5	2.8	7.0	1.5
RLPM10 00D443A	3Φ380V 50Hz	0.4	1.2	1.2	0.4
RLPM10 00D7543A	3Φ380V 50Hz	0.75	2.2	2.7	0.75
RLPM10 01D543A	3Φ380V 50Hz	1.5	3.2	4.0	1.5

RLPB1 0 03D743A	3Φ380V 50Hz	3.7	6.8	8.5	3.7
RLPB1 0 05D543A	3Φ380V 50Hz	5.5	10	12.5	5.5
RLPB1 0 07D543A	3Φ380V 50Hz	7.5	14	17.5	7.5
RLPB1 0 001143A	3Φ380V 50Hz	11	19	24	11
RLPB1 0 001543A	3Φ380V 50Hz	15	26	33	15
RLPB1 0 18D543A	3Φ380V 50Hz	18.5	32	40	18.5
RLPB1 0 002243A	3Φ380V 50Hz	22	37	47	22
RLPB1 0 003043A	3Φ380V 50Hz	30	52	65	30
RLPB1 0 003743A	3Φ380V 50Hz	37	64	80	37
RLPB1 0 004543A	3Φ380V 50Hz	45	72	91	45
RLPB1 0 005543A	3Φ380V 50Hz	55	84	110	55

Type	Input Voltage	Power (KW)	Inverter Capacity (KVA)	Output Current (A)	Suitable (Motor)
RLPA10 00D423A	One & Three Phase 220V 50Hz	0.4	1.0	2.5	0.4
RLPA 10 00D7523A	One & Three Phase 220V 50Hz	0.75	2.0	5.0	0.75
RLPA 10 01D523A	One & Three Phase 220V 50Hz	1.5	2.8	7.0	1.5
RLPA 10 02D223A	One & Three Phase 220V 50Hz	2.2	4.4	11	2.2
RLPA 10 03D723A	One & Three Phase 220V 50Hz	3.7	6.8	17	3.7
RLPA 10 00D443A	3Φ380V 50Hz	0.4	1.2	1.2	0.4
RLPA 10 00D7543A	3Φ380V 50Hz	0.75	2.2	2.7	0.75

RLPA 10 01D543A	3Φ380V 50Hz	1.5	3.2	4.0	1.5
RLPA 10 02D243A	3Φ380V 50Hz	2.2	4.0	5.0	2.2
RLPA 10 03D743A	3Φ380V 50Hz	3.7	6.8	8.5	3.7
RLPA 10 05D543A	3Φ380V 50Hz	5.5	10	12.5	5.5
RLPA 10 07D543A	3Φ380V 50Hz	7.5	14	17.5	7.5
RLPA10 001143A	3Φ380V 50Hz	11	19	24	11
RLPA 10 001543A	3Φ380V 50Hz	15	26	33	15
RLPA 10 18D543A	3Φ380V 50Hz	18.5	32	40	18.5
RLPA 10 002243A	3Φ380V 50Hz	22	37	47	22
RLPA 10 003043A	3Φ380V 50Hz	30	52	65	30
RLPA 10 003743A	3Φ380V 50Hz	37	64	80	37
RLPA 10 004543A	3Φ380V 50Hz	45	72	91	45
RLPA 10 005543A	3Φ380V 50Hz	55	84	110	55
RLPA 10 007543A	3Φ380V 50Hz	75	116	152	75
RLPA 10 009043A	3Φ380V 50Hz	90	134	176	90
RLPA 10 011043A	3Φ380V 50Hz	110	160	210	110
RLPA 10 013243A	3Φ380V 50Hz	132	193	253	132
RLPA 10 016043A	3Φ380V 50Hz	160	230	304	160
RLPA 10 018543A	3Φ380V 50Hz	185	260	340	185
RLPA 10 020043A	3Φ380V 50Hz	200	290	380	200
RLPA 10 022043A	3Φ380V 50Hz	220	325	426	220
RLPA 10 025043A	3Φ380V 50Hz	250	481	480	250
RLPA 10 028043A	3Φ380V 50Hz	280	427	560	280
RLPA 10 030043A	3Φ380V 50Hz	300	450	580	300
RLPA 10 031543A	3Φ380V 50Hz	315	460	605	315
RLPA 10 034543A	3Φ380V 50Hz	345	502	660	345
RLPA 10 037543A	3Φ380V 50Hz	375	544	715	375
RLPA 10 040043A	3Φ380V 50Hz	400	582	765	400
RLPA 10 041543A	3Φ380V 50Hz	415	604	795	415

V. Wiring

(1) Introduction of Wiring Terminals

DMM10 00D423A-DMM10 01D523A DMM10 00D443A-DMM10 01D543A

R	T	PR	P	U	V	W
----------	----------	-----------	----------	----------	----------	----------

DMB10 03D743A-DMB10 07D543A

E	R	S	T	U	V	W	P	PR
----------	----------	----------	----------	----------	----------	----------	----------	-----------

DMB10 001143A-DMB10 18D543A

E	R	S	T	P	Pr	N	U	V	W
----------	----------	----------	----------	----------	-----------	----------	----------	----------	----------

DMA10 00D423A-DMA10 02D223A DMA10 00D443A-DMA10 02D243A

E	R	S	T	P	Pr	U	V	W
----------	----------	----------	----------	----------	-----------	----------	----------	----------

DMA10 03D723A-DMA10 07D523A DMA10 03D743A-DMA10 07D543A

N	P	Pr	U	V	W
E	R	S	T		

DMA10 001143A- DMA10 003043A DMB10 003043A-DMB10 005543A

R	S	T	E	P	N	U	V	W
----------	----------	----------	----------	----------	----------	----------	----------	----------

DMA10 003743A- DMA10 009043A

R	S	T	E	P	Pr	N	U	V	W
----------	----------	----------	----------	----------	-----------	----------	----------	----------	----------

(2) Arrangement of Main Circuit Terminals

KA	KB	SPL	SPM	SPH	RST	REV	FOR	GND	VI	AI	+10	VO
----	----	-----	-----	-----	-----	-----	-----	-----	----	----	-----	----

DMM10 00D423A- DMM10 01D523A DMM10 00D443A- DMM10 01D543A

FA	FB	FC	KA	KB		IP24	SPL	SPM	SPH	RST	DCM	REV	FOR
+10V	VI	AI	XI	ACM	VO	AO	ACM	RS-	RS+		DCM	DRV	UPF

DMA10 00D423A- DMA10 03D723A DMA10 00D443A- DMA10 03D743A

FA	FB	FC	KA	KB	EV	UPF	DRV	DCM	SPL	SPM	SPH	>>
----	----	----	----	----	----	-----	-----	-----	-----	-----	-----	----

>>	RST	REV	FOR	+10	VI	AI	ACM	AO	RS+	RS-
----	-----	-----	-----	-----	----	----	-----	----	-----	-----

DMB10 03D743A- DMB10 07D543A

FA	FB	FC	KA	KB	IP24	UPF	DRV	DCM	SPL	SPM	SPH	>>
----	----	----	----	----	------	-----	-----	-----	-----	-----	-----	----

>>	RST	REV	FOR	+10	VI	AI	ACM	VO	AO	RS+	RS-
----	-----	-----	-----	-----	----	----	-----	----	----	-----	-----

DMA10 001143A- DMA10 0031543A

FA	FB	FC	KA	KB
----	----	----	----	----

IP24	UPF	DRV	SPL	SPM	SPH	RST	DCM	REV	FOR	IA-	IA+
DCM	+10	VI	AI	ACM	VO	AO	ACM	RS+	RS-	IB-	IA+

DMB10 07D543A- DMB10 005543A

(3) Introduction of RLPA and RLPB Series Main Circuit Terminals

Symbol	Function Description
R.S.T	Input terminal of AC line power. (220V class, for both single/three phase, single phase connected to any two phases)
U.V.W	Output terminal of the inverter
P.Pr	Connector for braking resistor.
P, N	Connecting terminal of external braking bank.
E	Ground terminal: the third method of grounding for 220V and special grounding for 380 V of Electrical Engineering Regulations.

(4) Introduction of RLPA and RLPB Series Control Terminals

Symbol	Function Description	Factory Setting
FOR	Multi-Input 1	Forward run
REV	Multi-Input 2	Reverse run
RST	Multi-Input 3	Reset
SPH	Multi-Input 4	High speed
SPM	Multi-Input 5	Middle Speed
SPL	Multi-Input 6	Low Speed
DCM	Common Terminal of Digital and Control Signals, IP 24 Power Ground	
EV (IPV)	+12V Power Supply	Max. output current 200mA
IP24	+24V Power Supply	Max. output current 200mA
+10	Power Supply for Speed Setting	+10V
VI	Analog Voltage Frequency Command	0—+10V corresponding to the highest operating
AI	Analog Current Frequency Command	4~20mA corresponding to the highest operating frequency
XI	Analog Input	
AO	Output Current	
VO	Output voltage	
ACM	Common Terminal of Analog and Control	
DRV	Multi-Output 1 (Optical couple output)	DC24V/100mA
UPF	Multi-Output 2 (Optical couple output)	
FA FB FC	Multi-Output 3 (N/O or N/C)	3A/250VAC, 3A/30VDC
RS+ RS-	RS485 Communication port	

(5) Introduction of RLPM Series Main Circuit Terminals

Symbol	Function Description
R.S.T	Input terminal of AC line power. (220V class, for both single/three phase, single phase connected to any two phases)
U.V.W	Output terminal of the inverter
P.Pr	Connector for braking resistor.

(6) Introduction of RLPM Series Control Terminals

Symbol	Function Description	Factory Setting
FOR	Multi-Input 1	Forward run
REV(D2)	Multi-Input 2	Reverse run
RST(D3)	Multi-Input 3	Reset
SPH(D4)	Multi-Input 4	High speed
SPM(D5)	Multi-Input 5	Middle Speed
SPL(D6)	Multi-Input 6	Low Speed
GND	Common Terminal of Digital and Control Signals, IP 24 Power Ground	
+10	Power Supply for Speed Setting	+10V
VI	Analog Voltage Frequency Command	0—+10V corresponding to the highest operating
AI	Analog Current Frequency Command	4~20mA corresponding to the highest operating frequency
VO	Output voltage	
KA KB	Multi-Output 3 (N/O or N/C)	3A/250VAC, 3A/30VDC

Nameplate Description of HLP Series Inverter

(5) Basic Connection Diagram

The wiring of the inverter is divided into two parts, main circuit terminal connections and control circuit terminal connections. The user can see the main circuit terminals and the control circuit terminals after removing the cover of enclosure. The terminals must be connected correctly as the following wiring circuit diagrams.

The following diagram shows the factory standard connection of RLP series.

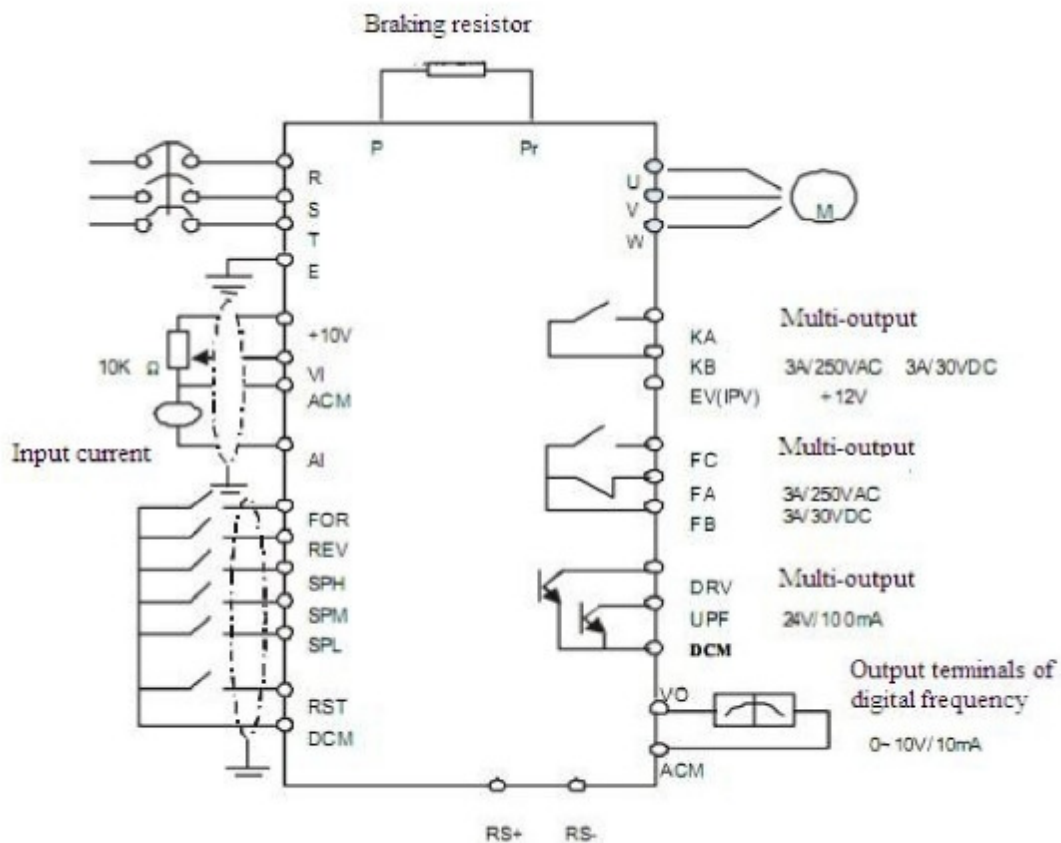

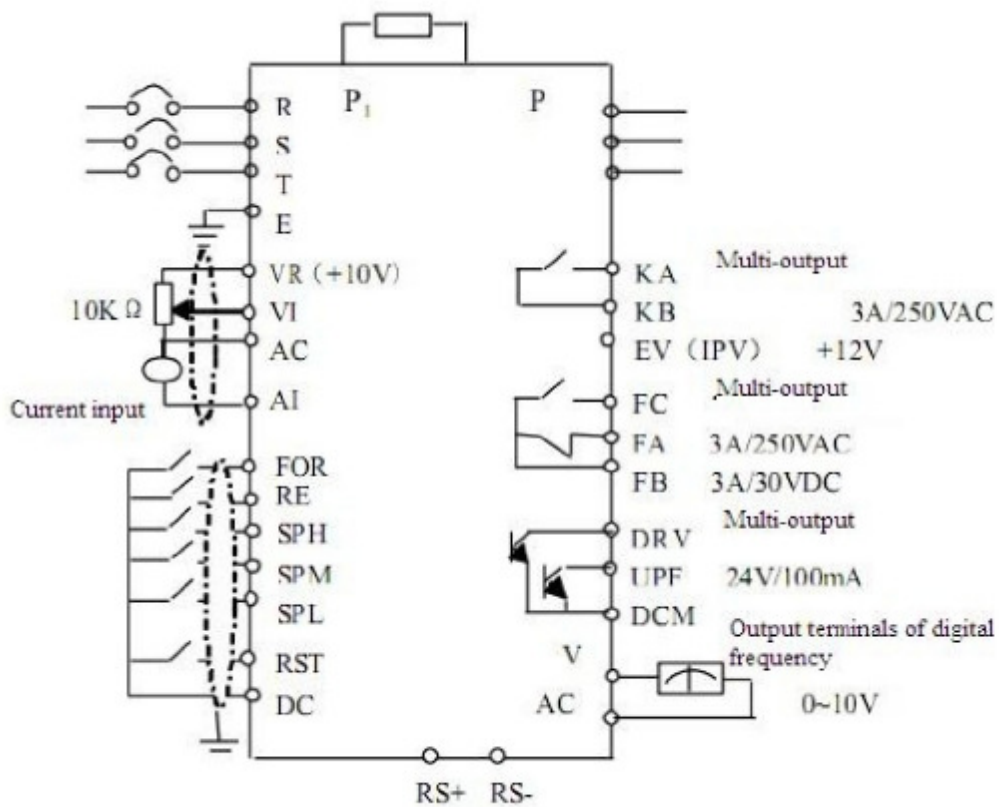

Brake chopper and brake module connecting terminal

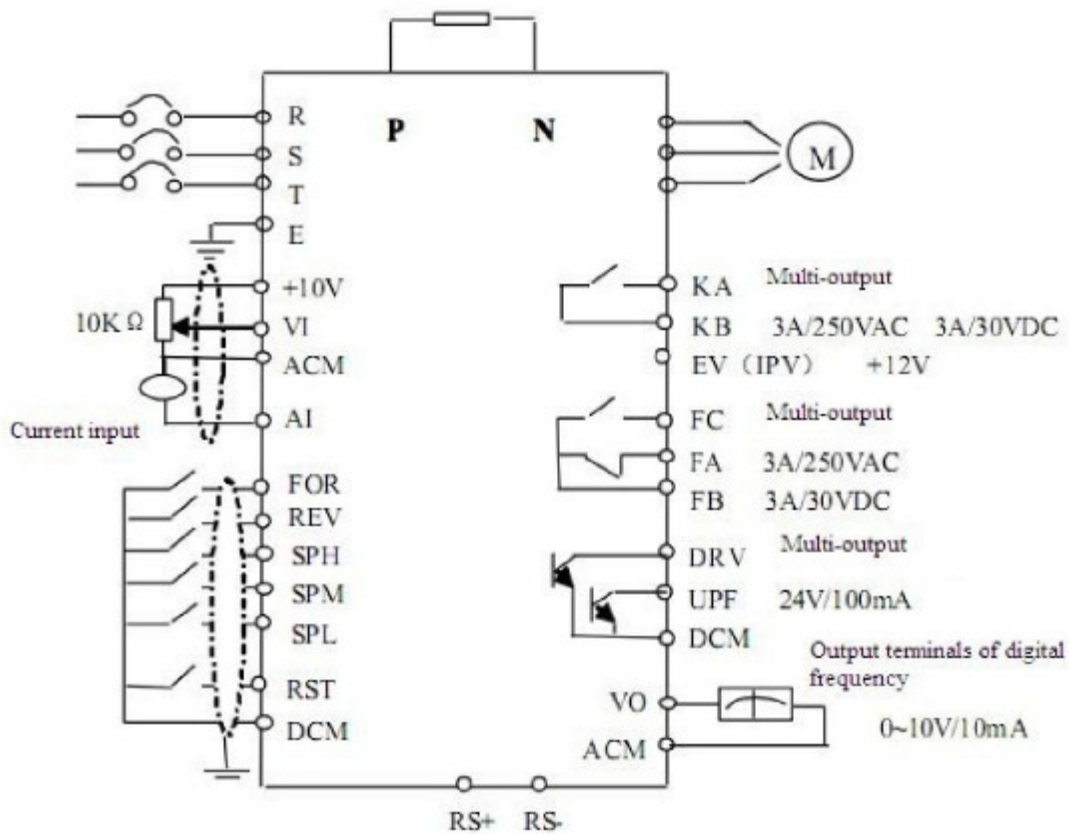

(6) Precautions on Wiring

1) For the main circuit wiring:

- While wiring, the sizes and specifications of wires should be selected and the wiring should be executed according to the electrical engineering regulations to ensure the safety.
- It is better to use shielded wire or wire and conduit for power cord and ground the shielded layer or two ends of wire conduit.
- Be sure to install a Non Fuse Breaker (NFB) between the power supply and the input terminals (R.S.T). (If using ground fault circuit interrupter, please choose one corresponding to high frequency).
- Never connect AC power to the output terminal (U.V.W) of the inverter.
- Output wires mustn't be in touch of the metal part of the inverter enclosure, or it will result in earth short-circuit.
- Phase-shifting capacitors, LC, RC noise filters, etc, can never be connected to the output terminals of the inverter.
- The main circuit wire must be enough far away from other control equipments.
- When the wiring between the inverter and the motor exceeds 15 meters for 220V class or 30 meters for 380V class, much higher dV/dT will be produced inside the coil of the motor, which will cause the destruction to the interlay or insulation of the motor. Please use a dedicated AC motor for the inverter or add a reactor at the inverter.
- Please lower the carrier frequency when there is a longer distance between the inverter and the motor. Because the higher the carrier frequency is the bigger the leakage current of high-order harmonics in the cables will be. The leakage current will have unfavorable effect on the inverter and other equipment.

VI. Instruction of the Digital Operator

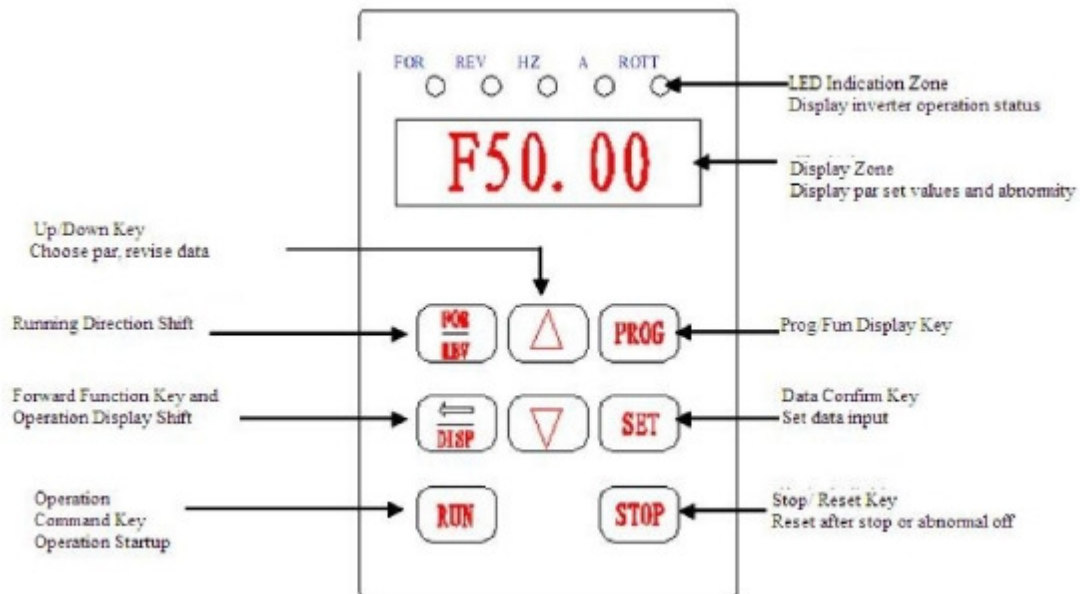

Introduction of RLPA Series Digital Operator

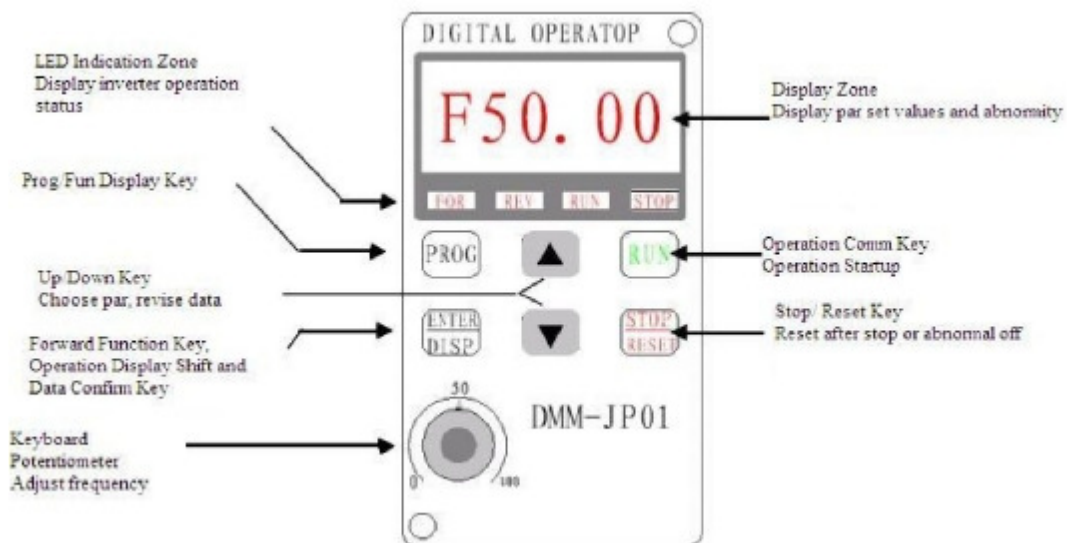

Introduction of RLPM Series Digital Operator

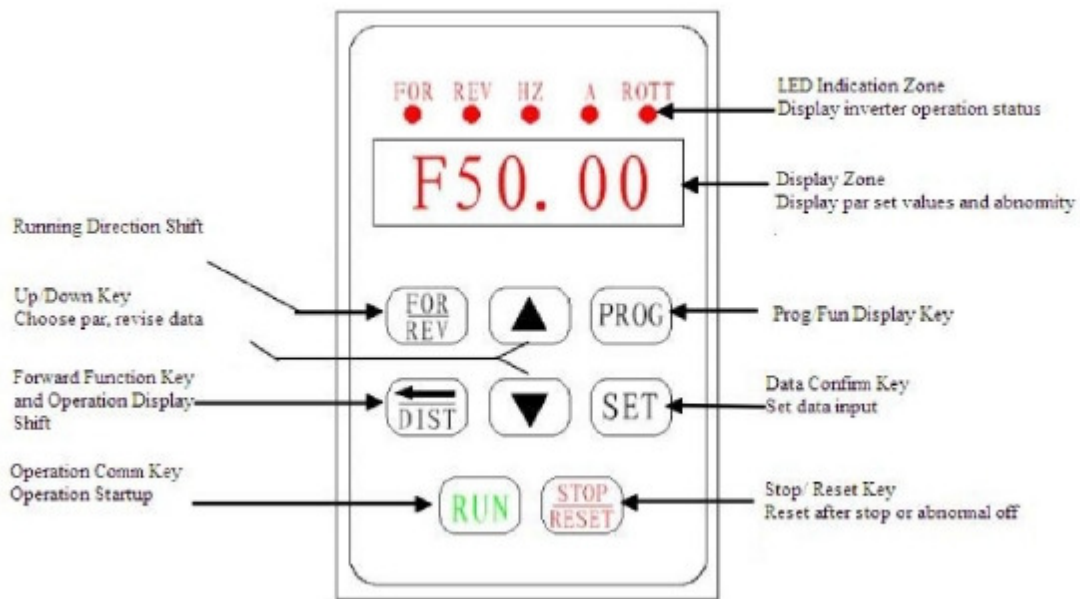

Introduction of RLPB Series Digital Operator (3.7KW-7.5KW)

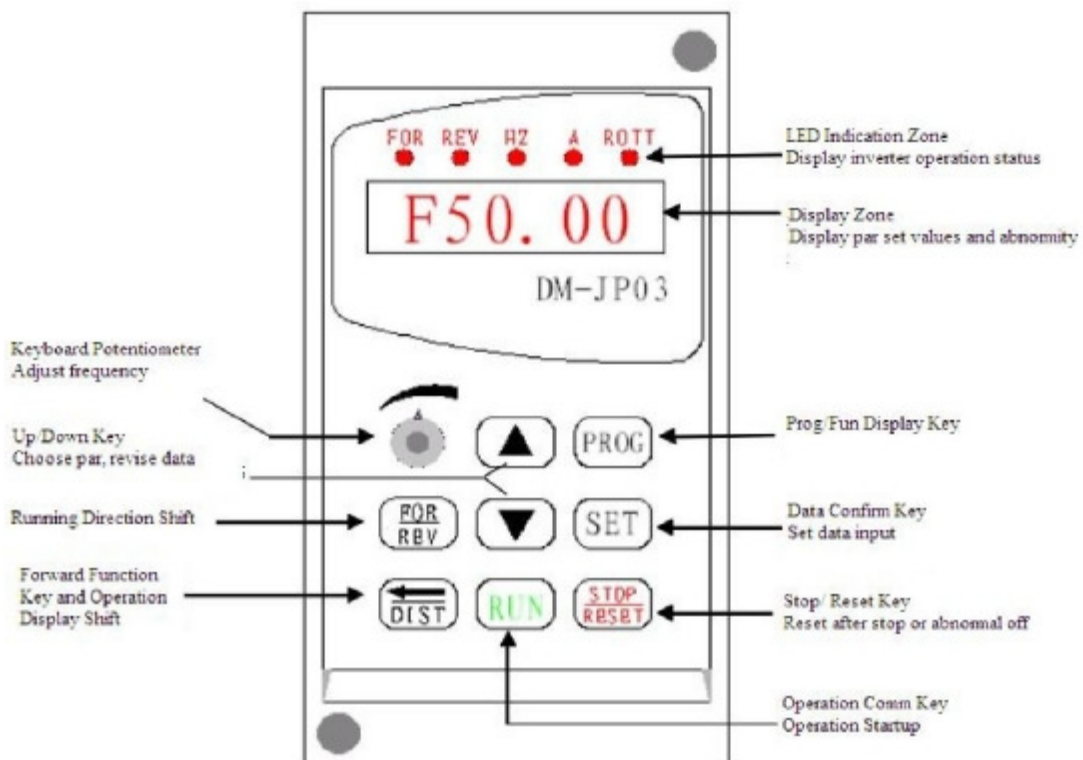

Introduction of RLPB Series Digital Operator (11KW-18.5KW)

2. Indicator Lamps

1) Description of RLPA and RLPB Series Indicator Lamp Status

Indicator lamp	Status	Description
FOR	on	The motor is in forward rotation.
REV	on	The motor is in reverse rotation.
HZ	on	Displaying set frequency or output
A	on	Displaying output current.

ROTT	on	Displaying rated motor revolution
A ROTT	on	Displaying AC or DC voltage.
HZ ROTT	on	Displaying counting value.
HZ A ROTT	on	Displaying internal temperature of the

2) Description of RLPM Series Indicator Lamp Status

Indicator lamp	Status	Description
FOR RUN	on	The motor is in forward rotation.
REV RUN	on	The motor is in reverse rotation.
FOR STOP	on	The motor is stopped.
REV STOP	on	The motor is stopped.

3) Description of RLPM Series Display Items

Item	Description
50.00	Present output Frequency is 50.00Hz
50.00	Present set frequency is 50.00HZ
3.00	Present output current is 3.0A
1440	Present output revolution is 1440r/min
510.1	Present DC voltage is 510.1 V
380.0	Present AC voltage is 380.0V
35.0	Present inverter's temperature is 35.0℃
50.0	Present target value of P1PJ is 50.0%
48.0	Present feedback value of PID is 48.0%

4) Description of RLPA and RLPB Series Display Items

Item	Indicator Lamp is ON	Description
50.00	H Z A R/min □ ○ ○	Present output Frequency is 50.00Hz
F50.00	H Z A R/min □ ○ ○	Present set frequency is 50.00Hz
R003.0	H Z A R/min ○ ○ □	Present output current is 3.0A
0144.0	H Z A R/min ○ ○ □	Present output revolution is 1440r/min
510.1	H Z A R/min ○ □ □	Present DC voltage is 510.1 V
380.0	H Z A R/min ○ □ □	Present AC voltage is 380.0V
535.0	H Z A R/min □ □ □	Present inverter's temperature is 35.0°C
00105	H Z A R/min □ ○ □	Present counter's value is 105
50.0	H Z A R/min ○ ○ ○	Present target value of P1PJ is 50.0%
048.0	H Z A R/min ○ ○ ○	Present feedback value of PID is 48.0%
00108	H Z A R/min ○ □ □	Total run time of inverter is 108 hours

5) Description of RLPA and RLPB Series Digital Operation

Procedures	Display	Indicator Lamp	Explanation
Power up, Operation of power			Self detect when power-up, display version no. (Flashing) and finally set frequency.
PROG	PD000		Enter programming Display the function of PD000
SET	000.00		Display the contents of PD000
	50.00 END-50.00 PD000 050.00		Change the content of PD000 Confirm changed value. Display END 50.00 PD001 Black from programming.

	50.00		Display running and operating frequency
			Display running and operating frequency
	A005.0		Monitor screen switching, display output current
	01440		Monitor screen switching, display rotation speed
			Switch back to main screen, display set frequency
			Switch of For./Rev. rotation, display the status of Rev rotation
	050.00		Switch to adjustable frequency
	030.00		Adjust set frequency, i.e. the value of PD000
	030.00		Determine the changed value, input to PD003
			Stop

Note: (1)  means flashing;  means bright;

- (2) For monitoring AC, DC, F and other items, they can be only switched and displayed after the parameter setting;
- (3) When it is powered up again after a power breakdown, the inverter will display the screen previous to the power breakdown after its self-detection.

VII. Commissioning

1. Important Checks before the Commissioning

- If there is any wrong with connected wires, pay special attention to the terminal of U.V.W. (Make sure the power supply wires are connected to R.S.T.)
- If there is any metal powder or wires left on the base plate of the inverter or the terminal block, which may cause short circuit.
- If screws are tightly locked and if the connecting parts are loose.
- If there is any short circuit or earth fault at outputs.

2. Commissioning Methods

The procedure of the operator is factory set up for the control mode of RLP series. The commissioning can be carried out through the digital operator.

Generally, the commissioning can be conducted at 5.00 Hz.

Procedures	Display	Indicator Lamp	Explanation
Power up ↓	RST1. 1 → Vr1. 0 000.00	FOR HZ ● □	Self detect when power up, display version no. and finally set frequency.
△	000.00	FOR HZ ● □	Switch to adjustable frequency on the panel
↓ ← △	050.00	FOR HZ ● □	Change set frequency, i.e. the value of CPD003
↓ SET	F 50.00	FOR HZ ● □	Confirm changed value
↓ RUN	F 50.00	FOR HZ □ □	Run at 50Hz
↓ STOP	F 50.00	FOR HZ ● □	Stop

VIII. Function List

Parameter and Function List (Part 1)

Category	Code	Function	Set Range & Function Explanation	Factory Setting
Basic Parameters	PD000	Parameter Lock	0: Invalid; 1: Valid	0
	PD001	Control Method	0. Operator 1. External terminal	0
	PD002	Selection of Frequency Setting	0. Operator 1. External terminal 2. Communication port 3. Operator potentiometer	0
	PD003	Main Frequency	0.01~400.00 Hz	*
	PD004	Base Frequency	0.01~400.00 Hz	50.00
	PD005	Max Operating Frequency	10.00~400.00Hz	50.00
	PD006	Intermediate Frequency	0.01~400.00 Hz	2.50/3.00
	PD007	Min. Frequency	0.01~20.00Hz	0.50
	PD008	Max. Voltage	0.1V~*	220/380
	PD009	Intermediate Voltage	0.1V~*	*
	PD010	Min. Voltage	0.1V~50.0V	*
	PD011	Frequency Lower	0.00~400.00 Hz	0
	PD012	Reserved		
	PD013	Parameter Reset	8 Restore the factory setting.	00
	PD014	Accel. Time 1	0.1~6500.0S	*
	PD015	Decel. Time 1	0.1~6500.0S	*
	PD016	Accel. Time 2	0.1~6500.0S	*
	PD017	Decel. Time 2	0.1~6500.0S	*
	PD018	Accel. Time 3	0.1~6500.0S	*
	PD019	Decel. Time 3	0.1~6500.0S	*
	PD020	Accel. Time 4	0.1~6500.0S	*
	PD021	Decel. Time 4	0.1~6500.0S	*
PD022	Reserved			
	PD023	Inverse Rotation not Allowed	0: Inverse rotation not allowed 1: Inverse rotation allowed	1
	PD024	Invalid Stop Key	0: STOP invalid 1: STOP valid	1
Applicable Parameters	PD025	Starting Mode	0: Start from Starting Frequency 1: Frequency track start	0
	PD026	Stopping Mode	0: Decelerating stop 1: Coasting stop	0
	PD027	Startup Frequency	0.1~10.0Hz	0.5
	PD028	Stop Frequency	0.1~10.0Hz	0.5
	PD029	Startup Brake Time	0~25.0	0.0

PD030	Stop Brake Time	0~25.0	0.0
PD031	DC Brake Base	0.0~20.0%	2.0
PD032	Frequency Track Time	0.1~20.0S	5.00
PD033	Frequency Track Current Base	0.1~200.0S	150.0
PD034	Voltage Rise Time of Frequency Track	0.1~10S	0.5
PD035- PD040	Reserved		
PD041	Carrier Frequency	0~15	*
PD042	Jogging Frequency	0.00~400.00Hz	5.00
PD043	S Curve Time	0~6500S	0

Parameter and Function List (Part 2)

Category	Code	Function	Set Range & Function Explanation	Factory Setting
Input and	PD044	FOR(D1) Function	0:Invalid; 1:Run; 2:For rotation;3: Rev rotation;4:Stop; 5:	02
	PD045	REV(D2) Function	FOR/REV.; 6:Jog; 7: Jog For rotation;8:Jog Rev Rotation;	03
	PD046	RST(D3) Function	9: External control time 1; 10: External control timer 2;11:	14
	PD047	SPH(D4) Function	Reserved; 12: Overheat of heat sink or motor; 13:	22
	PD048	SPM(D5) Function	Emergent stop; 14: Reset; 15~16; Reserved; 17:	23
	PD049	SPL (D6) Function	Accel/Decel time select 1; 18: Accel/Decel time select2; 19: Multi-speed 1; 20: Multi-speed 2; 21: Multi-speed 3; 22: High speed; 23: Middle speed; 24: Low speed; 25: PID Allowed; 26: Reserved; 27: Up; 28: Down; 29: Traction allowed; 30: Reserved; 31: Pulse counter; 32: Pulse counter reset	24
Output Terminal s	PD050	Y1 Output Function	0: Invalid; 1: Run; 2: Zero Speed Indication; 3: Fault indication; 4: DC Braking indication; 5:Set Frequency	01
	PD051	Y2 Output Function	reach; 6: In Accel; 7: In Decel.; 8: Arbitrary Frequency 1 reach; 9: Arbitrary Frequency 2 reach;10: Motor Overload	05
	PD052	(FA, FB and FC Terminals) Output Function	Alarm; 11: Over-torque Alarm; 12:Inverter Overload Alarm; 13: Counter Reach; 14~16: Reserved; 17: Low Voltage Alarm; 18: Internal Control Multi-speed End	03
	PD053	(KA and KB Terminals) Output Function	Indication; 19: Internal Control Multi-speed Process End Indication; 20~26: Reserved; 27: Traction End Indication; 28: PID Low Limit Alarm Indication; 29: PID Up Limit Alarm Indication; 30: Reserved; 31: Braking Resistor Act; 32: Fan act indication	00
	PD054	VO Output Function	Output of digital frequency signals 0-7	0
	PD055	VO Analog Output Gain	0.0~100.0%	0.00
	PD056	Skip Frequency 1	0.00~400.00	0.00
	PD057	Skip Frequency 2	0.00~400.00	0.00
	PD058	Skip Frequency 3	0.00~400.00	0.00
	Pd059	Skip Frequency	0.10~10.00Hz	0.50
	Pd060	Uniform Frequency 1	0.00~400.00Hz	0.1
	Pd061	Uniform Frequency 2	0.00~400.00Hz	0.00
	Pd062	Uniform Frequency Range Setting	0.10~10.00Hz	0.50
Pd063	Timer 1	0.1~10.0	0.1	
Pd064	Timer 2	1~100	1	
PD065	Counting Value Set	00~65500	00	
PD066	Intermediate Counter Value	0~65500	0	
PD067- PD069	Reserved			

Parameter and Function List (Part 3)

Category	Code	Function	Set Range & Function Explanation	Factory Setting
	PD070	Analog Input Select	0: 0~10V 1: 0~5V 2: 0~20mA 3: 4~20mA 4: 0~10V, 4~20mA stacked 5: External pulse input	0
	PD071	Analog Filtering Constant	0~50	20
	PD072	Higher Analog Frequency	0.00~400.00 Hz	50.00
	PD073	Lower Analog Frequency	0.00~400.00 Hz	0
	PD074	Bias Direction at Higher Frequency	0: Positive 1: Negative	0
	PD075	Bias Direction at Lower Frequency	0: Positive 1: Negative	0
	PD076	Analog Negative Bias Reverse: allowable.	0: Not Allowable 1: Allowable	0
	PD077	Up/ Down Memory Function Select	0: Not memorized 1: Memorized	0
	PD078	Up/ Down Stack Select	0: 0.01Hz 1: 0.1Hz	0
	PD079	Reserved		
Category	Code	Function	Set Range & Function Explanation	Factory Setting
Multi-Speed	PD080	Running Mode Select	0: General running 1: Internal control 16-speed 2: External control 4-speed 3: External control 8-speed 4: Traction 5: Interference	0
	PD081	Internal Control Multi-speed Running Mode Select	0: Stop after running one cycle 1: Cycled running 2: Stop after automatic running one cycle (Stop interval) 3: Automatic cycled running (Stop interval)	0
	PD082	Internal Control Front 8-speed Running Direction	0~255 (0: Positive; 1: Negative)	0
	PD083	Internal Control Back 8-speed Running Direction	0~255 (0: Positive; 1: Negative)	0
	PD084	Internal Control Front 8-speed Accel/ Decel Time	0~65535	0

	PD085	Internal Control Back 8-speed Accel/ Decel Time	0~65535	0
	PD086	Frequency 2 Set	0.00-400.00Hz	15.00
	PD087	Frequency 3 Set	0.00-400.00Hz	20.00
	PD088	Frequency 4 Set	0.00-400.00Hz	25.00
	PD089	Frequency 5 Set	0.00-400.00Hz	30.00
	PD090	Frequency 6 Set	0.00-400.00Hz	35.00
	PD091	Frequency 7 Set	0.00-400.00Hz	40.00
	PD092	Frequency 8 Set	0.00-400.00Hz	0.50
	PD093	Frequency 9 Set	0.00-400.00Hz	10.00
	PD094	Frequency 10 Set	0.00-400.00Hz	15.00
	PD095	Frequency 11 Set	0.00-400.00Hz	20.00
	PD096	Frequency 12 Set	0.00-400.00Hz	25.00
	PD097	Frequency 13 Set	0.00-400.00Hz	30.00
	PD098	Frequency 14 Set	0.00-400.00Hz	35.00
	PD099	Frequency 15 Set	0.00-400.00Hz	40.00
	PD100	Frequency 16 Set	0.00-400.00Hz	45.00
	PD101	Internal Control Multi-speed Timer 1	0.0-6500.0S	10.0
	PD102	Internal Control Multi-speed Timer 2	0.0-6500.0S	10.0
	PD103	Internal Control Multi-speed Timer 3	0.0-6500.0S	0.0
	PD104	Internal Control Multi-speed Timer 4	0.0-6500.0S	0.0
	PD105	Internal Control Multi-speed Timer 5	0.0-6500.0S	0.0
	PD106	Internal Control Multi-speed Timer 6	0.0-6500.0S	0.0
	PD107	Internal Control Multi-speed Timer 7	0.0-6500.0S	0.0
	PD108	Internal Control Multi-speed Timer 8	0.0-6500.0S	0.0
	PD109	Internal Control Multi-speed Timer 9	0.0-6500.0S	0.0
	PD110	Internal Control Multi-speed Timer 10	0.0-6500.0S	0.0
	PD111	Internal Control Multi-speed Timer 11	0.0-6500.0S	0.0
	PD112	Internal Control Multi-speed Timer 12	0.0-6500.0S	0.0
	PD113	Internal Control Multi-speed Timer 13	0.0-6500.0S	0.0
	PD114	Internal Control Multi-speed Timer 14	0.0-6500.0S	0.0
	PD115	Internal Control Multi-speed Timer 15	0.0-6500.0S	0.0
	PD116	Internal Control Multi-speed Timer 16	0.0-6500.0S	0.0
	PD117	Internal Control Multi-speed Memory	0-1	0

Parameter and Function List (Part 4)

Category	Code	Function	Set Range & Function Explanation	Factory Setting
	PD118	Over-voltage Speed-loss Select	0-1	1
	PD119	Speed-loss Base during Accel	0-200	150
	PD120	Speed-loss Base during Constant Speed	0-200	0
	PD121	Speed-loss Decl Time during Constant Speed	0.1-25.5	5
	PD122	Speed-loss Level during Decl	0-200	150
	PD123	Over-torque Detection Mode Select	0-3	0
	PD124	Over-torque Detection Level	0-200	0
	PD125	Over-torque Detection Time	0.1-20.0	1.0
	PD126	Pulse Counter Memory	0-1	0
	PD127- PD129	Reserved		
Water Supply Under Constant Pressure	PD130	Number of Auxiliary Pump	0-2	0
	PD131	Continuous Operating Time of Aux. Pumps	1-9000min	60
	PD132	Interlocking Time of Aux. Pumps	1-250s	5s
	PD133	High Speed Running Time	1-250s	60s
	PD134	Low Speed Running Time	1-250s	60s
	PD135	Stopping Voltage Level	1-150%	95%
	PD136	Lasting Time of Stopping Voltage Level	1-250s	30s
	PD137	Wakeup Level	1-150%	80%
	PD138	Sleep Frequency	0.00-400.0	20.00
	PD139	Lasting Time of Sleep Frequency	1-250s	20s
	PD140	Reserved		
	PD141	Rated Motor Voltage	Set upon motor nameplate	*
	PD142	Rated Motor Current	Set upon motor nameplate	*
Parameters of Motor Functions	PD143	Motor Pole No.	02—10	04
	PD144	Rated Motor Revolution	00—9999	1440
	PD145	Automatic Torque Compensation	2.0-10.0	2, 0
	PD146	Motor No-load Current	0—100	40
	PD147	Motor Slip Compensation	0.0-100	0.0
	PD148- PD149	Reserved		
	PD150	AVR Function	0-1	1
	PD151	Automatic Energy Conservation	0-20	0
	PD152	Breakdown Restart Time	0.2-25	1
	PD153	Stop Restart Select	0 : Invalid; 1 : Frequency track	0
	PD154	Allowable Breakdown Time	0.1-5.0s	0.5
	PD155	Breakdown Restart Number	0-10	00

Parameter and Function List (Part 5)

Category	Code	Function	Set Range & Function Explanation	Factory Setting
PID Parameters	PD156	Proportional Constant	0.0-1000.00%	100%
	PD157	Integral Time (I)	0.1-3600.00s	5.0
	PD158	Differential Time (D)	0.01-10.00s	0
	PD159	Target Value	0.0-100.00%	0
	PD160	Target Value Select	0: Set by the operator 1: Set by external terminals	0
	PD161 PD162	PID Upper Limit PID Lower Limit	0~100% 0~100%	100% 0%
Communication Function	PD163	Communication Address	0-250	0
	PD164	Communication Baud Rate	0-3	1
	PD165	Communication Data Method	0-5	0
	PD166- PD169	Reserved		
	PD170	Display Items	0-5	0
Monitoring Parameters	PD171	Display Items Open	0-15	0
	PD172	Fault Clear	00- 10 (01means Fault Clear)	*
	PD173	Rated Voltage of Inverter	Set upon Model	
	PD174	Rated Current of Inverter	Set upon Model	
	PD175	Type of Inverter		
	PD176	Standard of Inverter Frequency	0:50Hz 1:60Hz	
	PD177	Fault Record 1	Note:----No fault record	*
	PD178	Fault Record 2		---
	PD179	Fault Record 3		---
	PD180	Fault Record 4		----
PD181	Software Version No.		----	
PD182	Ex-factory Date	Year Month Day	*	
	PD183	Serial Number		*
	PD184- PD250	Reserved		

IX. Descriptions of Functions

PD000 Parameters Lock		
Set Range: 0-1	Unit: 1	Factory Setting: 0

0: Invalid

1: Valid, means parameters are locked. Except for this parameter, all parameters are not allowed to be changed.

It can prevent the wrong operations by non-professionals, thus causing unnecessary dangers and mistakes.

It can be changed by pressing ▲ or ▼.

PD001 Control Mode Select		
Set Range: 0-2	Unit: 1	Factory Setting: 0

0: Keyboard is set.

The running orders are given by the keyboard.

1: External switch input terminal programming

The running orders are given by the external terminals, which are set by 6-speed programmable terminals.

2: Communication port is set.

The running orders are given by the communication port.

PD002 Frequency Set Select		
Set Range: 0-3	Unit: 1	Factory Setting: 0

0: Keyboard set The current operation frequency is set by the keyboard Pd003.

1: Analog set The current operation frequency is controlled by the input analog signals, whose type is decided by Pd070. Refer to Pd070-Pd076 for related parameters.

2: Modbus set The current operation frequency is set by the communication port.

3: Operator potentiometer set The current operation frequency is set by the operator potentiometer.

Pd003 Main Frequency		**
Set Range: 0.00-400.00Hz	Unit: 0.01Hz	Factory Setting: 0.00

In the digital operator mode, the inverter will run at the set value of Pd003. During running, the operating frequency can be changed by pressing ▲ or ▼. During multi-speed running, the main frequency is taken as the frequency of speed 1.

In the external control multi-speed mode, if Pd002 is set to 1, ie. given by an external terminal, Speed 1 will be given by the analog of the external terminal.

The setting of main frequency is limited by the maximum operating frequency.

The related parameters of Pd002, Pd080, are adjustable during operation.

Pd004 Base Frequency	**
Set Range:0.01-400.00Hz Unit: 0.01Hz	Factory Setting: 50.00

This parameter must be set according to the rated frequency of operating voltage on the motor's nameplate. Under normal conditions, do not change the set value of base frequency at will. If it is equipped with a special motor, this value should be set properly according to the characteristics of the motor's parameters. Otherwise it may cause the damage to the equipment.

Pd005 Max. Operating Frequency	
Set Range:10.00-400.00Hz Unit: 0.01Hz	Factory Setting: 50.00

This parameter determines the max operating frequency of the inverter.

Pd006 Intermediate Frequency	
Set Range:0.01-400.00Hz Unit: 0.01Hz	Factory Setting: 2.50

Note: ** means this parameter is adjustable during the operation.

This parameter is set for an intermediate frequency value of arbitrary V/F curve. If it is set improperly, it will cause over-current or under-torque of the motor, or even tripping of the inverter.

The intermediate frequency set value is restricted by the base frequency set value.

Pd007 Min. Frequency	
Set Range:0.01-20.00Hz Unit: 0.01Hz	Factory Setting: 0.50

This parameter decides the minimum startup frequency in the V/F curve.

Pd008 Max. Voltage	
Set Range:0.1-*	Unit: 0.1V Factory Setting: 220/380V

This parameter should be set according to the rated value of the motor's nameplate. The factory setting is 380V for 380V class motor and 220V for 220V class motor. The setting range of this parameter is restricted by the voltage rating of the inverter. In case of the motor relatively far away from the inverter, this set value can be increased properly.

Pd009 Intermediate Voltage	
Set Range:0.1-510.0V Unit: 0.1V	Factory Setting: 15/27.5

This parameter is set for an intermediate voltage value of arbitrary V/F curve. If it is set improperly, it will cause over-current or under-torque of the motor, or even tripping of the inverter. When the intermediate frequency is increased, the voltage will increase the output torque and at the same time also the output current. When changing this parameter, please pay attention to monitoring the output current to avoid the inverter's tripping due to over-current.

The factory setting of 220V class inverter is 15 and that for 380V is 27.5.

This set value of intermediate voltage is limited by the set value of max voltage.

When the voltage is increasing to a certain value at intermediate frequency, the torque compensation will lose its function. When adjusting this parameter, the output current

of the inverter should be increased from low to high slowly according to the load of machines until it meets the starting requirement. Do not be quick to increase it by large amplitude. Otherwise it might cause the tripping of the inverter or the damage of the machines.

Pd010 Min. Voltage		
Set Range:0.1-380.0V	Unit: 0.1V	Factory Setting: *

This parameter determines the minimum startup voltage in the V/F curve.

The factory setting is 8 for 220V class inverter and 13.5 for 380V class inverter.

The setting value of Pd010 is restricted by the voltage of maximum operating frequency.

Pd011 Lower Limit Frequency		
Set Range:0.00-400.00	Unit: 0.01Hz	Factory Setting: 0.00

The lower limit frequency is set to avoid the wrong operation of site workers, thus preventing the motor from overheating or mechanical breakdowns due to too low frequency.

The lower limit frequency must be lower than the setting value of upper limit frequency.

The following table is the factory setting for RLPA, RLPB and RLPM series V/F curve, acceleration/ deceleration time, and filtering wave.

Param Model	Pd009	Pd010	Pd014	Pd015	Pd041	Param Model	Pd009	Pd010	Pd014	Pd015	Pd041
00D423A	15.0	7.5	5	5	9	003043A	17	8.5	30	30	4
0D7523A	14.0	7	8	8	9	003743A	16	8	35	35	4
01D523A	14.0	7	10	10	8	004543A	16	8	40	40	4
02D223A	13.0	6.5	10	10	8	005543A	15	7.5	45	45	3
03D723A	13.0	6.5	15	15	7	007543A	15	7.5	50	50	3
0D7543A	22	11	8	8	9	022043A	11	5.5	250	250	2
01D543A	22	11	10	10	8	025043A	11	5.5	250	250	2
02D243A	21	10.5	15	15	8	028043A	11	5.5	250	250	2
03D743A	21	10.5	15	15	7	030043A	10	5	250	250	2
05D543A	20	10	15	15	6	031543A	10	5	250	250	2
07D543A	20	10	20	20	6	034543A	10	5	250	250	2
001143A	19	9.5	20	20	5	037543A	10	5	250	250	2
001543A	19	9.5	20	20	5	040043A	10	5	250	250	2
18D543A	18	9	25	25	5	041543A	10	5	250	250	2
002243A	18	9	25	25	5						

- Note:
- Ramp Time 2 = Ramp Time 1 x 2
 - Ramp Time 3 = Ramp Time 2 x 2
 - Ramp Time 4 = Ramp Time 3 x 2
 - Min.Voltage Value = Intermediate Voltage Value/2
 - The intermediate frequency is 2.5 for the system of 50Hz.
 - The intermediate frequency is 3.0 for the system of 60Hz.

Pd012 Reserved

The following are several curves and set values often used for reference. Specific curves must be set according to concrete characteristics of mechanical load.

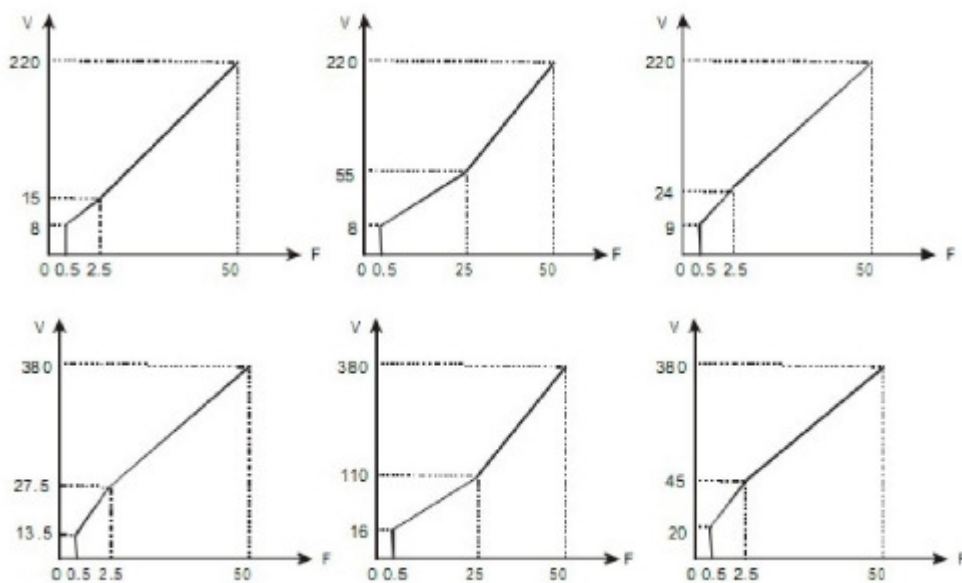

Curve of constant torque

Curve of lower torque

Curve of higher torque

Pd013 Parameter Reset

Set Range: 00-10

Unit: 1

Factory Setting: 00

When the value for a parameter is set improper or is abnormal for some reasons, this parameter can be set to 08 to restore it to the factory setting and then reset. After the parameters are locked (in case of Pd000=1), the parameters can't be reset. They can only be reset after unlock. For related parameters, refer to P013.

PD014	Accel. Time 1			**
	Set Range: 01—	6500.0S	Unit: 01S	Factory Setting: *
P015	Decel. Time 1			**
	Set Range: 01—	6500.0S	Unit: 01S	Factory Setting: *
P016	Accel. Time 2			**
	Set Range: 01—	6500.0S	Unit: 01S	Factory Setting: *
P017	Decel. Time 2			**
	Set Range: 01—	6500.0S	Unit: 01S	Factory Setting: *
P018	Accel. Time 3			**
	Set Range: 01—	6500.0S	Unit: 01S	Factory Setting: *

P019	Decel. Time 3			***
	Set Range: 01—	6500.0S	Unit: 01S	Factory Setting: *
P020	Accel. Time 4			**
	Set Range: 01—	6500.0S	Unit: 01S	Factory Setting: *
P021	Decel. Time 4			**
	Set Range: 01—	6500.0S	Unit: 01S	Factory Setting: *

Ramp-up time means the time needed for the inverter to increase the frequency from 0Hz to the maximum operating frequency (See t1 in the diagram). Ramp-down Time means the time needed for the inverter to decrease the frequency from the maximum operating frequency to 0Hz (See t2 in the diagram).

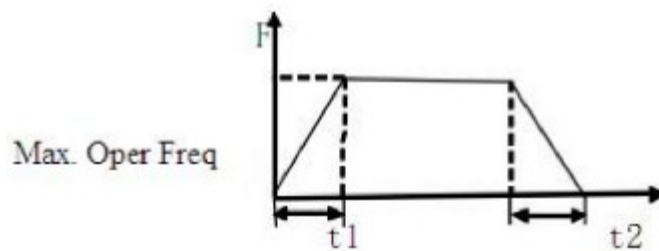

M Series inverter has altogether 4 Ramp Times. For Ramp Time 2,3,4, the user can select the different ramp up or down time through the external terminals or switching of ramp time according to the actual needs. In the internal control multi-speed operation, different ramp time can be selected through easy PLC.

Generally the default of the inverter is Ramp Time 1, which is factory set depending on the model. Ramp Time 4 is for the jogging ramp time. For the factory setting of parameters refer to the table in CD006.

The related parameters: Pd044-Pd049, Pd084, Pd085

Pd022 Factory Reserved

Pd023 Rev Rotation Disable			
Set Range: 0-1	Unit: 1	Factory Setting: 1	

0: Rev rotation disables.

1: Rev Rotation enables.

This function is suitable for the motor, which is not allowed to rotate reversely, to prevent workers from false operation. When the reverse rotation is disabled, the motor can only rotate forward, not reverse.

Pd024 Stop Key Invalid			
Set Range: 0-1	Unit: 1	Factory Setting: 1	

0: STOP key invalid.

1: STOP key valid.

This parameter set is only valid when Pd001 is set to 1 or 2.

Pd025 Starting Mode			
Set Range: 0-1	Unit: 1	Factory Setting: 0	

Two starting modes are available for the needs of different equipment.

0: Start from the starting frequency.

When Pd 029 is set to 0, i.e. DC braking is invalid at start, it starts running from the starting frequency. When Pd029 is set to any non-zero value, i.e. DC braking is valid at start, it first performs a DC braking at start, and then starts from the starting frequency.

For the related parameters refer to Pd027, Pd029 and Pd031.

1: Start by frequency track

This setting can be used for the restarting of large inertia load. When restarting, the inverter will trace the former frequency from the set frequency downward. In case of large inertia equipment, when restarting, it can implement the running command and track the former frequency right away without waiting for the complete stop of the equipment to save time.

Note: When the inverter is restarted by frequency track, it will start tracking the frequency from its set frequency downward, and search it at the highest speed. When restarting, the current becomes higher, and over-current or stall may occur. So attention must be paid to the adjustment of current level of frequency track. Generally, Pd033 is adjusted around 100. The concrete value can be set according to the characteristics of mechanical load.

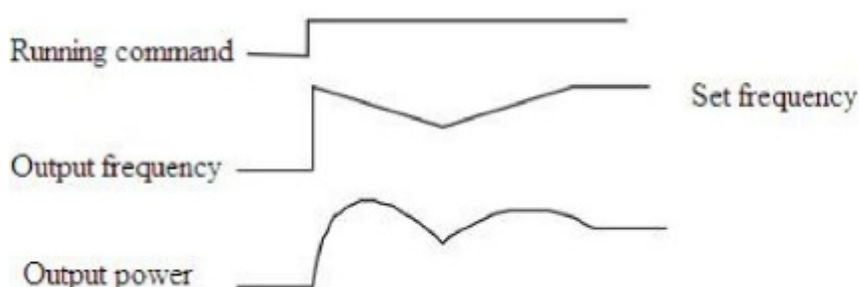

Pd026 Stopping Mode	Unit: 1	Factory Setting: 0
Set Range: 0-1		

0: Decelerating Stop

When Pd030 is set to 0, DC braking is invalid. When DC braking is invalid, the inverter will decelerate to the stopping frequency, and then stop outputs, and the motor will coast to stop. When CD142 is set to any non-zero value, DC braking is valid, and the inverter will first decelerate to the stopping frequency, and then stop by DC braking.

DC braking at stop is usually used for high position stop or for positioning control. It must be noticed that frequent uses of DC braking will cause over-heat of the motor.

For the related parameters refer to Pd028, Pd030 and Pd031.

1: Coasting Stop

When the inverter receives a STOP command, it will immediately stop output and the motor will coast to stop. When the coasting stop mode is selected, DC braking is invalid.

Pd027 Starting Frequency		
Set Range: 0.1-10.0Hz	Unit: 0.1Hz	Factory Setting: 0.5

Starting frequency is the initial frequency when the inverter is started. If the starting frequency is set to 5.0Hz, the inverter will run between 5.0 Hz and the maximum operating frequency after its start at 5.0Hz. The actual maximum operating frequency is limited by the upper limit of frequency.

For the related parameters, refer to Pd025, Pd029 and Pd031.

Pd028 Stopping Frequency		
Set Range: 0.1-10.0Hz	Unit: 0.1Hz	Factory Setting: 0.5

When stopping, the inverter will decrease its frequency to the stopping frequency and then stop running or start DC braking to stop.

If Pd029 is set to 0, DC braking is invalid at stop and the inverter will stop running. If Pd029 is set for valid, the inverter will stop by DC braking after it reduces to the value of Pd028.

For the related parameters, refer to Pd028, Pd029 and Pd030.

Pd029 DC Brake Time at Start		
Set Range: 0.0-25.0S	Unit: 0.1S	Factory Setting: 0.0

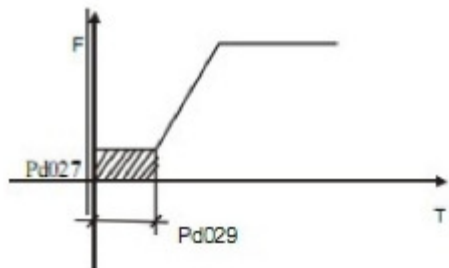

This parameter is set for DC Braking at start and the lasting time of DC Braking current to the motor. If it is set to zero, it means DC braking is invalid. DC braking at start is normally used in the application, in which the load is movable when the machine is at stop, such as winRLPill. Because of the load existing before the inverter drives, the motor is often in coasting with an uncertain rotation direction. So the DC braking can be executed before starting the motor to prevent the inverter from tripping.

When Pd025 is set to 0, it is valid.

For the related parameters, refer to Ph025, Ph029 and Ph031.

Pd030 DC Brake Time at Stop		
Set Range: 0.0-25.0	Unit: 0.1S	Factory Setting: 0.0

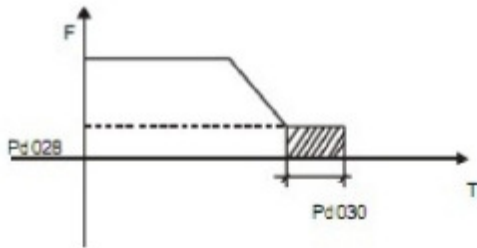

When this parameter is set to any non-zero value it starts DC brake at stop and sends the DC braking time to the motor. DC braking at stop is often used for a high-level stop or positioning control. When this parameter is set to zero, it closes DC braking at stop.

This setting is valid when PD026 is set to 0.

For the related parameters, refer to Ph026, Ph028 and Ph031.

Pd031 DC Braking Voltage Level		
Set Range: 0.0-20.0%	Unit: 0.1%	Factory Setting: 2.0

This parameter is set for the DC braking voltage to the motor at start and stop. It can be adjusted for different braking voltage. When adjusting the parameter, it must be increased slowly from lower value to high value, until the sufficient braking torque is achieved.

The voltage at maximum frequency is 100% voltage.

Pd032 Frequency Track Time		
Set Range: 0.0-20.0S	Unit: 0.1S	Factory Setting: 5.0

This parameter is set as frequency track time when the inverter is started by frequency track after an external abnormality or temporary power breakdown. For starting or stopping of some large inertia load, if restarting a machine after its complete stop, it will waste much time because of its large inertia of load. But if the frequency track is started, it is not necessary to wait for the machine to come to a full stop for restart.

The inverter will trace the frequency from high to low with the set frequency. After searching, it will continue to accelerate to reach the set frequency.

Pd033 Current Level for Frequency Track		
Set Range: 0-200%	Unit: 1%	Factory Setting: 150

When the inverter is tracing the frequency, this set value is taken as the level for output current. When the output current is higher than this level, the inverter will decrease the frequency to restore the current below the level and then it will execute the frequency track again.

Pd034 Voltage Rise Time during Frequency Track		Factory Setting: 0.5
--	--	----------------------

When the starting mode of the inverter is set to frequency track, there is a process of voltage rise during the frequency track. When the voltage is rising rapidly, the current will be higher and the tracking process will be faster. When the voltage is rising slowly, the current will be lower and the tracking process will be slower. In general

Pd043 S-Curve Time		
Set Range: 0-6500S	Unit: 1	Factory Setting: 1

This parameter can be set for no impact slow start or slow stop of the inverter when starting or stopping. When starting S-curve, the inverter will make accelerating or decelerating curve of different speed rates according to Ramp Time.

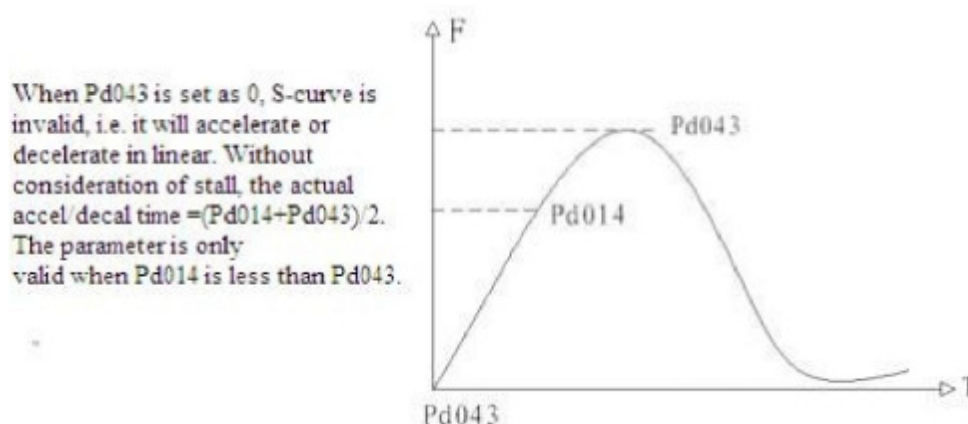

Pd044	D1 Terminal Function	Factory Setting: 02
Pd045	D2 Terminal Function	Factory Setting: 03
Pd046	D3 Terminal Function	Factory Setting: 14
Pd047	D4 Terminal Function	Factory Setting: 22
Pd048	D5 Terminal Function	Factory Setting: 24
Pd049	D6 Terminal Function	Factory Setting: 23
Set Range: 00-32	Unit:	

- 01: RUN Running. It can be combined with other terminals to compose multiple control modes.
- 02: FOR Forward Rotation
- 03: REV Reverse Rotation
- 04: STOP Stopping
- 05: FOR/REV Switching of FOR/REV rotation
- 06: JOG Jogging
- 07: Jog FOR Rotation
- 08: Jog REV Rotation
- 09: External Control When the contact is closed, the timer will start and begin to
Timer 1 Start: count time. When the timer reaches the set point, the corresponding multi-inputs will act.
- 10: External Control
Timer 2 Start
- 12: Over-heat of heat This contact can be used to detect over-heat of the heat sink or
sink or motor: motor to protect the motor and inverter.
- 13: Emergent Stop It can receive external emergent stop command or other fault signals.
- 14: RST Reset. This terminal can be used for reset after a fault is removed.
- 15~16: Reserved.

17: Ramp Time 1	This terminal can be used to select the ramp time of the inverter.
18: Ramp Time 2	4 kinds of ramp time are available for choice.
19: Multi-speed 1	8-speed setting can be composed through Multi-speed 1, 2, 3.
20: Multi-speed 2	
21: Multi-speed 3	
22: High speed	High, middle and low speed can compose three kinds of operation mode.
23: Middle speed	With different frequencies. In the three terminals the high-end signal has priority. Low, Middle and High Speed are determined respectively by Frequency 2, 3, 4.
24: Low speed	
25: PID Valid	When this contact is closed, PID function starts. PID Function start is only valid during operation.
26: Internal control multi-speed clear reset	This contact can realize the internal control multi-speed clear reset.
27: UP Function	When the switch of this terminal acts, the frequency setting of the inverter will be increased or decreased by one unit. When the switch of the terminal is held, the frequency will increase or decrease rapidly to a point and then increase or decrease at even speed. When the power is up again after the power breakdown the changed frequency will not be memorized.
28: Down Function	
29: Drawing Start	When this contact is triggered the drawing action starts.
31: Counter Pulse	When this terminal is set for the counter it can receive the pulse signal of $\leq 250\text{HZ}$ and counts.
32: Counter Reset	When this contact acts it will clear the present counting values displayed, restore C00 and restart counting.

Explanation:

1. Three multi-function terminals can be used for the connection method of three-wire system for the realization of switching of FOR/REV rotation, which is extensively applied in the cases of FOR/REV switching of photoelectric switches.

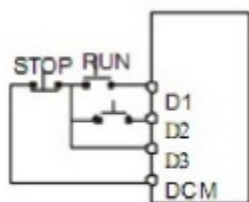

Select D1, D2 and D3.

Parameter setting:

Pd001=1 for external control; Pd044=02 for FOR rotation;

Pd045=03 for REV Rotation; Pd046=04 for Stop.

Action Description:

When triggering D1, the inverter will rotate forward (start);

When triggering D2, the inverter will rotate reverse;

When pressing STOP, the inverter will stop.

2. RUN, DCM, F/R can be used for Start, Stop and switching of FOR/REV:

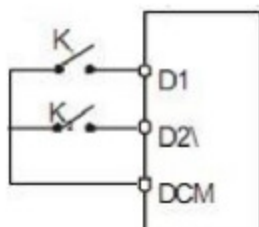

Select FOR, REV and RST.

□ Parameter setting: Pd001=1 for external control;
Pd044=01 for RUN function;
Pd045=05 for F/R switch;

When triggering FOR, the inverter will rotate forward (start); When triggering REV, the inverter will rotate reverse.

3. Description of Ramp Time 1 and 2:

- This function is only valid when Pd080 is set to 0, 2 and 3. Under the disturbance and internal control multi-speed, it is invalid.
- Any two multi-inputs can be combined for 4 kinds of ramp time for selection.
- The related multi-inputs are set for Ramp Time 1, 2. Take the terminals of D4 and D5 as example, when Pd047 of D4 is set to 22 and Pd048 of D5 is set to 23, D4 and D5 are now Ramp Time 1, 2.

D4	D5	Result
OFF	OFF	Ramp Time 1
ON	OFF	Ramp Time 2
OFF	ON	Ramp Time 3
ON	ON	Ramp Time 4

4. Function description of High, Middle and low speed terminals:

RUN	D6	D5	D4	Result
ON	OFF	OFF	OFF	Main speed, the frequency runs at the set value of Pd003.
ON	ON	OFF	OFF	Low speed, the frequency runs at the set value of Pd086.
ON	ON/OFF	ON	OFF	Middle speed, the frequency runs at the set value of Pd087.
ON	ON/OFF	ON/OFF	ON	High speed, the frequency runs at the set value of Pd088.

Note: (1) This function is only valid when Pd080 is set to 1, i.e. for 4-Speed of external control.

(2) Ramp time is determined by Ramp Select terminal.

(3) When all high, middle and low speeds have signal inputs, it will give priority in the sequence of high, middle and low speed.

5. Description of UP and DOWN Function:

UP	DOWN	Result
ON	OFF	Frequency increase
OFF	ON	Frequency decrease
ON	ON	Not increase or decrease

Note: (1) The function of UP and DOWN is only valid when the operator is selected for the source of the operating frequency, i.e. Pd002=0.

(2) When the UP terminal is closed, the frequency of the inverter will increase.

(3) When the DOWN terminal is closed, the frequency of the inverter will decrease.

(4) When both UP and DOWN terminals are closed at the same time, the frequency will neither increase nor decrease. It is regarded as invalid.

- (5) When the frequency reaches the max operating frequency, it will stop increasing.
- (6) When the frequency reaches the min frequency or its lower limit, it will stop decreasing.
- (7) After a power breakdown, the set value of CD000 will be memorized instead of the frequency.
- (8) When using the function of UP and DOWN, the keys of \triangle ∇ of the panel are valid. After changing the values, it needs to press SET (ENTER) key for confirmation and then the inverter can implement the action. Meanwhile, the value will write to Pd003, which will be memorized after a power breakdown.
- (9) When keeping pressing UP or DOWN, the frequency will increase or decrease rapidly to a point and then increase or decrease at even speed.
- (10) The value changed by UP or DOWN can be set through Pd077 for confirmation of whether it should be memorized or not memorized. For details, refer to Pd077.

6. Function Description of Counter:

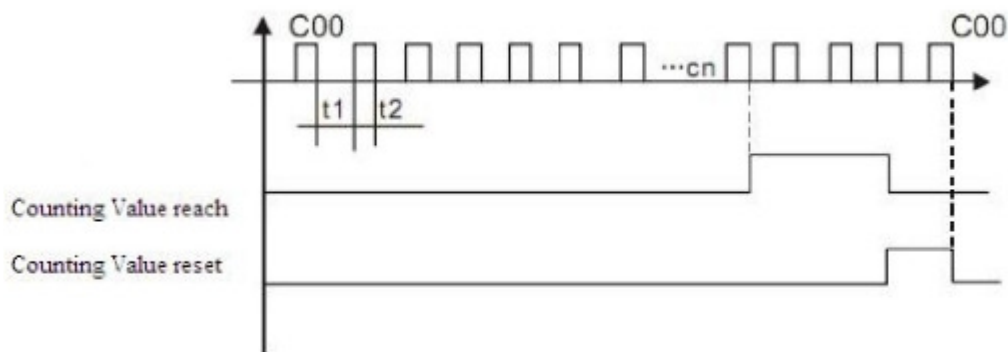

- Note: (1) The signal width triggered should not be lower than 2 msec ($t_1, t_2 > 2\text{msec}$) .
- (2) When the counting value is reached, the corresponding multi-output contact will act.
- (3) This counter can only count again after reset.
- (4) When reaching to 65535, the counter will not count again.

Pd050	Y1 Output	Factory Setting: 01
Pd051	Y2 Output	Factory Setting: 05
Pd052	FA, FB and FC Terminal Output	Factory Setting: 03
Pd053	KA and KB Terminal Output	Factory Setting: 00
	Set Range: 00-32	Unit: 1

01: RUN

The contact will act when the inverter has output or receives the running command.

02: Zero Speed	The contact will act when the output frequency of the inverter is less than its starting frequency.
03: Fault Indication	The contact will act when the inverter detects abnormal conditions.
04: DC Braking Indication	The contact will act when the inverter is in DC braking.
05: Set Frequency Reach	The contact will act when the output frequency of the inverter reaches the set frequency.
06: In Accel	The contact will act when the inverter is in ramp-up.
07: In Decel	The contact will act when the inverter is in ramp-down.
08: Uniform Frequency 1 Reach	The contact will act when the output frequency of the inverter reaches the designated frequency (Pd060).
09: Uniform Frequency 2 reach	The contact will act when the output frequency of the inverter reaches the designated frequency (Pd061).
10: Motor Overload Alarm	The contact will act when the inverter detects over-load of the motor.
11: In Over-torque Detect	The contact will act when the inverter detects over-torque.
12: Inverter Over-load Alarm	The contact will act when the inverter detects over-load.
13: Set Counter Reach	The contact will act when the inverter implements the external counter and the counting value is equal to the set value (Pd065).
14: Middle Counter Reach	The contact will act when the inverter implements the external counter and the counting value is greater than or equal to the set value (Pd066).
15: External Control Timer 1 reach	The contact will act when the timer 1 reaches the set value.
16: External Control Timer 2 reach	The contact will act when the timer 2 reaches the set value.
17: Low Voltage Alarm	The contact will act when the inverter detects low voltage.
18: Single Step End	The contact will act and generate one pulse when the inverter finishes a single step in implementation of program operation.
19: Process End	The contact will act and generate one pulse, when the inverter finishes all the steps (i.e. after one cycle) in implementation of program operation.
20: 4~20mA Disconnected	When AI input signal is opened the contact will act.
25: Auxiliary Pump 1	This contact controls the starting and stopping of auxiliary pumps. For details, refer to Operation of Multi-pumps.
26: Auxiliary Pump 2	

27: Drawing Reach	The contact will act when the drawing action is finished. The contact will automatically reset when the inverter stops.
28: PID Lower Limit Alarm	This contact will act when the PID feedback is smaller than the lower limit (the set value of Pd162).
29: PID Upper Limit Alarm	This contact will act when the PID feedback is greater than the upper limit (the set value of Pd161).
30: Braking Resistor Act	When the inverter is in running and the DC voltage reaches the braking voltage the contact will act.
31: Electromagnetic Relay Act	When the contact pulls in, the corresponding multi-function terminal will act.
32: Fan Act	When the temperature of the inverter is increased or it is in running, this contact will act.

Pd054 VO Output	Set Range: 0-7	Unit: 1	Factory Setting: 0
-----------------	----------------	---------	--------------------

Functions: Output terminal of digital frequency, generating pulse or 0—10V analog. In combination with Pd055, it can be connected with a corresponding instrument with the measuring range below 10 to be used for external monitoring.

0: 0~10V analog output, corresponding to output frequency. 0~10V corresponds to 0~Maximum operating frequency.

1: 0~10V analog output, corresponding to output current. 0~10V corresponds to 0~two times of the rated current of the inverter.

2: Analog output, corresponding to DC bus voltage. 0~10V corresponds to 0~1000V

3: Analog output, corresponding to AC output voltage. 0~10V corresponds to 0~510V/255V

(Note: The machine type of three phases, 380V corresponds to 510V and the machine type of single phase, 220V corresponds to 255V).

Pd055 VO Analog Output Gain	Set Range: 0.0-100.0%	Unit: 0.1%	Factory Setting: 100.0
-----------------------------	-----------------------	------------	------------------------

This parameter can be used to adjust the output voltage value of Multi-output 6 to adapt to frequency meters with different measuring range and also used to correct a frequency meter. For example, for an externally connected frequency meter with the measuring range of 0~5V, a multi-function terminal can be used to display its operating frequency. Then it can be corrected with this parameter. It can be achieved by setting Pd055=50.

Pd056 Skip Frequency 1	**
Pd057 Skip Frequency 2	
Pd058 Skip Frequency 3	
Set Range: 0.00—400.00 Hz	Unit: 0.01Hz Factory Setting: 0.00
Pd 059 Skip Frequency Range	**

Set Range: 0.10—10.00 Hz Unit: 0.01Hz Factory Setting: 0.50

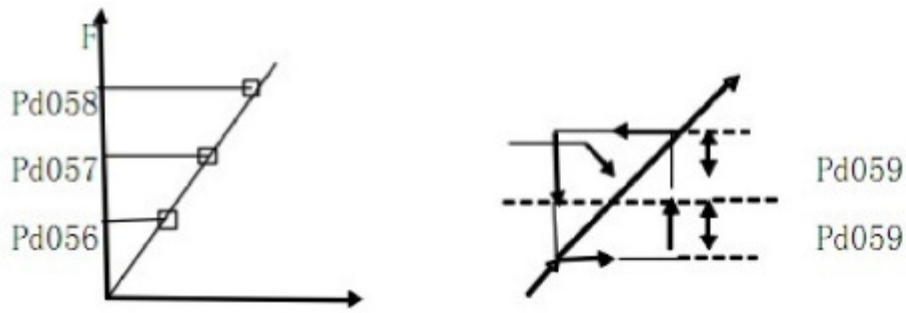

These three frequency skipping points are set for avoiding a mechanical resonance point. In case of Pd059=0, all skip frequencies are invalid. The actual skip frequency range is two times that of Pd059, as shown in the above diagram.

Pd060	Uniform Frequency 1	**
Pd061	Uniform Frequency 2	
	Set Range: 0.00—400.00 Hz	Unit: 0.01 Hz Factory Setting: 0.00
Pd062	Uniform Frequency Range	**
	Set Range: 0.10—10.00 Hz	Unit: 0.01 Hz <u>Factory Setting: 0.50</u>

When the output frequency is more than the uniform frequency, the corresponding multi-outputs will act. The uniform frequency range acts as a hysteresis loop. When the inverter is in the operation of multi-pumps, Pd060 (Uniform Frequency 1) is used as high speed frequency and CD062 is set as low speed operating frequency. The definitions of the corresponding multi-function contacts are changed.

Pd063	Timer 1 Time		
	Set Range : 01 ~ 10.0	Unit: 1	Factory Setting: 01
Pd064	Timer 2 Time		
	Set Range : 1 ~ 100	Unit: 1	Factory Setting: 1

Timer 1 is a timer of 01s ~ 10.0s and Timer 2 is a timer of 1s ~ 100s. When the timer start at multi-inputs is closed (on) the timer starts to count time. When it reaches the set time the corresponding multi-output contact will act. When the timer start is opened (off) the timer time at the multi-output will be reset.

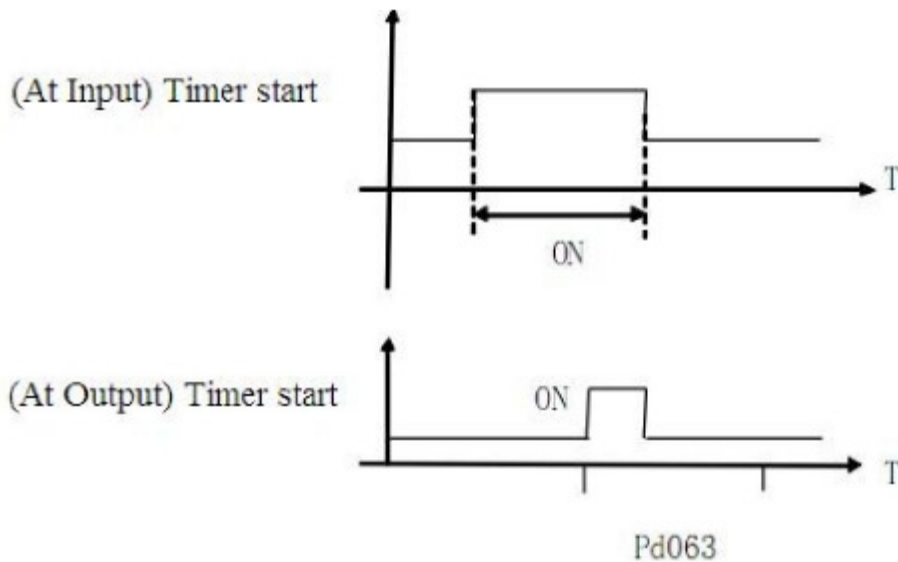

For example, set Pd063=5.0s. When the external control terminal (Multi-Input) is valid, the output terminal will be valid after five (5.0) seconds, the signal of which can be used to control other corresponding signals.

Pd065	Counting Value		**
	Set Range: 0-65500	Unit: 1	Factory Setting: 0

An external terminal of multi-function can be used as a trigger for the counter. When the counter reaches the set value of Pd065, the corresponding multi-output contact will act. After the counter is cleared and reset, it will start counting again. A proximity switch or optoelectronic switch can be used for the triggering signals.

Pd066	Pulse Intermediate Counting Value		
	Set Range: 0-65500	Unit: 1	Factory Setting: 0

Refer to Pd065.

Pd067-Pd069	Reserved		
-------------	----------	--	--

Pd070	Analog Input Select		
	Set Range: 0-4	Unit: 1	Factory Setting: 0

0: 0~10V 1: 0~5V 2: 0~20mA 3: 4~20mA 4: 0-10V and 4-20mA stacked

This parameter can be set for different analog input signals.

When Pd070=4, the output frequency = $1/2 (U/U_{max} + I/I_{max}) \times 50\text{Hz}$

Among which: U: Analog Voltage; U_{max} : Maximum Analog Voltage;

I: Analog Current; I_{max} : Maximum Analog Current.

Pd071	Analog Filtering Constant		
	Set Range: 0-50	Unit: 1	Factory Setting: 20

The setting of this parameter is related to the analog responding speed. The higher the value of Pd071 is set, the lower the analog responding speed will be.

Pd072	Higher Analog Frequency		
	Set Range: 0.00-400.00Hz	Unit: 0.01Hz	Factory Setting: 50.00
Pd073	Lower Analog Frequency		
	Set Range: 0.00-400.00Hz	Unit: 0.01Hz	Factory Setting: 0.00

Pd074	Bias Direction at Higher Frequency		
	Set Range: 0-1	Unit: 1	Factory Setting: 0
Pd075	Bias Direction at Lower Frequency		
	Set Range: 0-1	Unit: 1	Factory Setting: 0

0: Positive direction

1: Negative direction

Bias direction means the instruction of FOR/REV rotation command. Positive bias indicates forward rotation while negative bias indicates reverse rotation.

For details, refer to the diagram in Pd076.

Pd076	Analog Negative Bias Reverse	Unit: 1	Factory Setting: 0
Set Range: 0-1			

0: Negative bias Rev is not allowable.

1: Negative bias Rev is allowable.

The parameter group is set for the measuring range and zero point of the external analog terminals and can be combined for any kind of curve to control the operation of the motor.

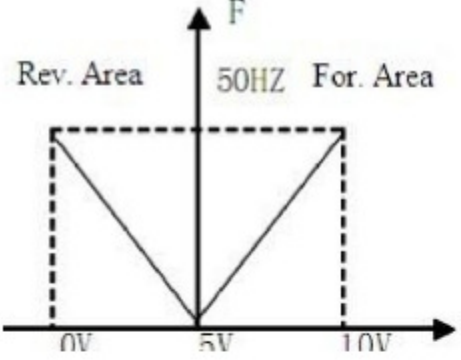

Setting: Pd073=50 Pd075=1
Pd072=50 Pd074=0
Pd076=1

Note: this curve can be easily used in complicated applications in combination with other curves. When using it the instruction of FOR/REV run from external terminals is still valid. When switching, the curve will turn reverse.

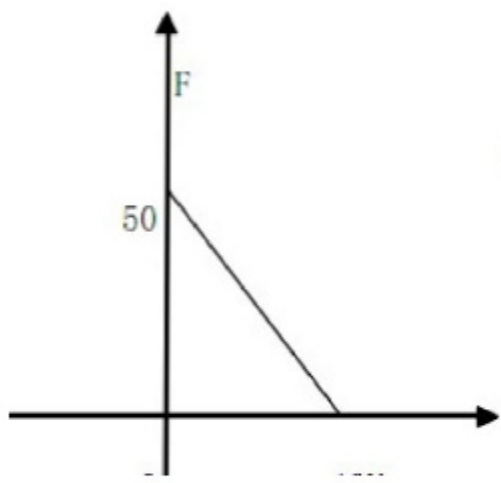

Setting: Pd073=50 Pd075=0
Pd072=0 Pd074=0
Pd076=0

Note: this curve is a kind of special application of reverse ramp setting. When using transmitter for the control of pressure, temperature and others and while the control has higher pressure and output signals, but requiring the corresponding commands of stop or deceleration on the inverter, this curve can satisfy the demand properly.

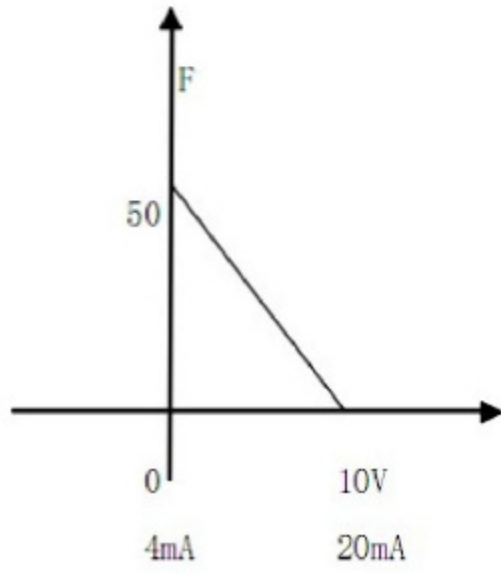

Setting: Pd073=10 Pd075=1
Pd072=40 Pd074=0
Pd076=1

Note: this method is used extensively. The user can use it flexibly.

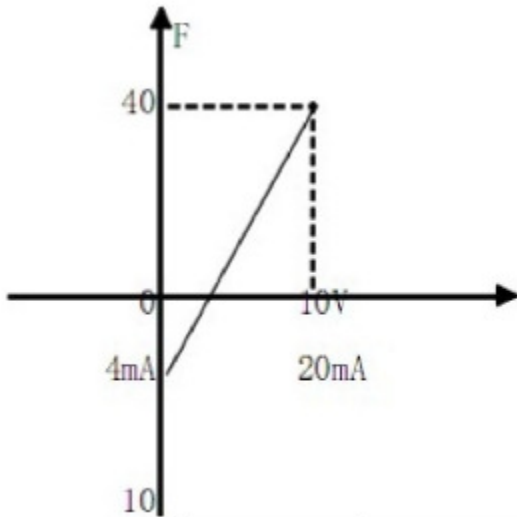

Setting: Pd073=10 Pd075=1
Pd072=40 Pd074=0
Pd076=0

Note: this curve is the extension of the above curve. 2V~10V (4.8mA~20mA) corresponds to 0Hz~40HZ; the signal of 0V~2V (4~4.8mA) is invalid. It can be used to avoid noise disturbance. In harsh environment it is better not to use signals below 1V for setting the operating frequency of the inverter.

Pd077	UP/DOWN Function		
	Set Range: 0-1	Unit: 1	Factory Setting: 0

0: Not memorized 1: Memorized

This parameter can be set for the selection of whether the values changed by the UP or DOWN shall be memorized or not after stop. The changed values whether to be memorized or not means when they are changed by UP or DOWN during operation and the inverter is restarted after stop, these changed values shall be memorized or not after restart. When Pd077 is set to 0, the changed value will not be memorized and when it is set to 1, the changed values will be memorized. The set values of Pd003 will be memorized after restart.

For the related parameters, refer to Pd044-Pd049.

Pd078	UP/DOWN Speed		
	Set Range: 0-1	Unit: 1	Factory Setting: 0

0: 0.01Hz. Minimum UP/DOWN speed is 0.01Hz.

1: 0.1Hz. Minimum UP/DOWN speed is 0.1Hz.

Through the changes of this set value, the UP/DOWN speed unit can be adjusted to meet the needs of different customers.

Pd079	Reserved		
-------	----------	--	--

Pd080	Operation Mode		
	Set Range: 0-5	Unit: 1	Factory Setting: 0

0: Normal operation, i.e. the inverter is running in the normal control mode.

1: Internal control multi-speed (16-speed)

Note: 8-Speeds is made by adding the main frequency to the 7-speeds.

- The ramp up/down time is determined by Pd084 and Pd085.
- The running time is set by Pd101~Pd116 timer. The unused control part can be set as 0 by the timer.
- The running direction of various frequencies can be set by Pd082 and Pd083.
- When the internal control multi-speed is running, the running time and direction are set by the internal parameters. The external time switch and

FOR/ REV. switch are invalid.

2. External control 4-speed (Refer to the function description and diagram of three terminals of high, middle and low speed in Pd044~Pd049)

3. External control multi-speeds

Multi-function Terminals			Results
Multi-speed 1	Multi-speed 2	Multi-speed 3	
OFF	OFF	OFF	Main frequency and frequencies are determined by Pd003 or potentiometer.
ON	OFF	OFF	Multi-speed 1 and frequency are determined by Pd086.
OFF	ON	OFF	Multi-speed 2 and frequency are determined by Pd087.
ON	ON	OFF	Multi-speed 3 and frequency are determined by Pd088.
OFF	OFF	ON	Multi-speed 4 and frequency are determined by Pd089.
ON	OFF	ON	Multi-speed 5 and frequency are determined by Pd090.
OFF	ON	ON	Multi-speed 6 and frequency are determined by Pd091.
ON	ON	ON	Multi-speed 7 and frequency are determined by Pd092.

Note: It is only valid to realize the external control 8-Speeds operation when Multi-inputs are set for Multi-speed 1, 2, 3 and Pd080 is set to 3.

- Multi-speed 1, 2, 3 can be used to make up 7-Speeds and adding the main frequency.
- The frequencies of Speed Step 1 ~ Step 7 are determined by Pd086~Pd092.
- Each ramp time is determined by D1-D6 external terminal.
- The directions of each program operation are determined by the external multi-function terminals.
- The main frequency can be set in two ways. One method is to set it through Pd003 and another is to set it through the potentiometer. When Pd002 is set to 1, the frequency of Main Frequency is set by the potentiometer.

For the related parameters, refer to Pd003, Pd002 and Pd086~Pd092.

4. Disturbance (Traverse function)

This is a special parameter in the chemical fiber and printing and dying industries to realize the traverse function. Except the commands of stop, external faults and emergency stop all other commands are not accepted at running.

Note: The frequency at each inflection point is determined by Pd003 and Pd086.

- Skip Frequency is determined by Pd092.
- Running Time is determined by Timer Pd101 and Pd102.
- The related parameters: Pd003, Pd086~Pd116.

5. Drawing

This is a special parameter for the constant speed of unwinding and rewinding. By using this function, the linear speed constant in certain accuracy can be realized.

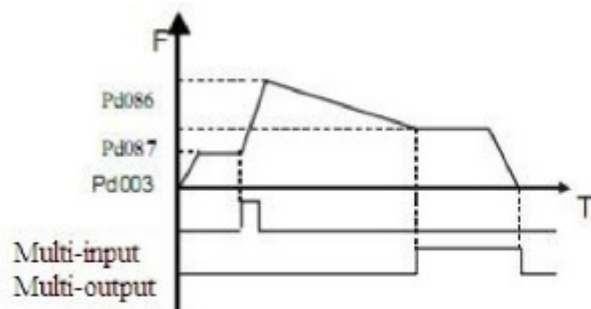

- Note:
- Through triggering of the external multi-function terminal, the drawing action begins.
 - In implementation of the drawing action, the actual running time is $T = Pd101 \times 10$.
 - When the drawing action is finished, the inverter will run at the constant speed of Pd087 and the corresponding multi-output contact will act at the same time. Until receiving the STOP command, the inverter will stop running and the multi-output contact will reset.

Pd081	Auto PLA	Unit: 1	Factory Setting: 0
	Set Range: 0-3		

0: Stop after the program runs one cycle.

1: Cycling running.

2: Stop after it runs one cycle automatically (STOP for intervention).

3: Auto running and cycling (STOP for intervention)

This parameter setting is only valid when Pd080 is set to 4. For relevant Parameters, refer to Pd003, Pd080, Pd082~Pd116.

Explanation:

1. Stop after the program runs one cycle.

When the command of auto program operation is given, the inverter will run with each set value of internal parameters. It will run for one cycle and then stop automatically. The inverter will not restart and run until it receives another command of operation.

2. Cycling run.

When the command of operation is given, the inverter will run in sequence with the frequency of every speed step and running time set by each of the internal parameters and will recycle. During the cycling run, except the commands of stop, external faults and emergency stop, all other commands will not be accepted.

3. Stop after it runs one cycle automatically (STOP for intervention).

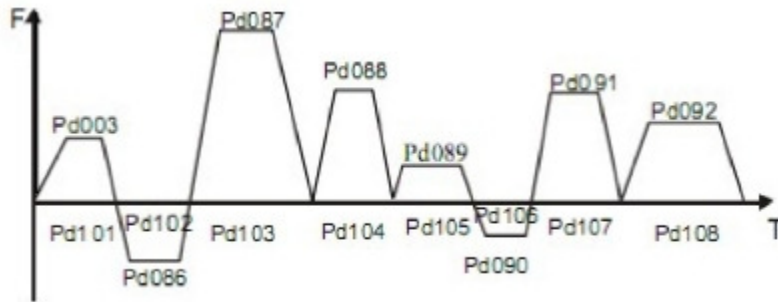

Note: 1) When the command of auto program operation is given, the inverter will run with each parameter. But it will stop first and then restart at changing of each step and will stop automatically after running for one cycle. The inverter will not restart and run until it receives another command of operation.

2) The frequencies of each speed step are set by Pd003, Pd086~Pd092.

3) The running times of each speed step are set by Pd101~Pd108.

4) The running direction is set by Pd082.

Pd082	Running Direction of First 8-speeds		
Pd083	Running Direction of Last 8-speeds		
	Set Range: 0-255	Unit: 1	Factory Setting: 0

This parameter is only valid when Pd080 is set to 1.

This parameter setting determines the running direction of each frequency of Pd086-Pd092, and Pd003 in the program operation. The setting method is as follows: The rotation direction is set first in the binary 8 bits mode, and then converted to a decimal value for the setting of this parameter. For instance:

The parameter 01001010 is converted into a decimal value, that is:

$$1 \times 2^6 + 1 \times 2^3 + 1 \times 2^1 = 64 + 8 + 2 = 74$$

Then parameter Pd082=74

Pd083 is the setting for the last 8-speed running direction (the calculation method is same as Pd082).

Pd084	Ram Up Time of First 8-speeds		
Pd085	Ram Down Time of Last 8-speeds		
	Set Range: 0~65535	Unit: 1S	Factory Setting: 0

This parameter is only valid when Pd080 is set to 1.

This parameter is set to determine the ramp time values of the internal control multi-speed. The setting method is as follows:

(1) Determine each Ramp Time in the binary 2 bit mode:

Bit1	Bit0	Ramp Time
0	0	Ramp Time 1 Pd014, Pd015
0	1	Ramp Time 2 Pd016, Pd017
1	0	Ramp Time 3 Pd018, Pd019
1	1	Ramp Time 4 Pd020, Pd021

(2) Determine the Ramp time of each speed step in the binary 16 bit mode:

Step 8		Step 7		Step 6		Step 5		Step 4		Step 3		Step 2		Step 1	
t8		t7		t6		t5		t4		t3		t2		t1	
0	0	0	0	0	0	0	0	0	1	1	0	0	0	1	1

t1 Select Ramp Time 4
t2 Select Ramp Time 1
t3 Select Ramp Time 3
t4 Select Ramp Time 2
t5 Select Ramp Time 1
t6 Select Ramp Time 1
t7 Select Ramp Time 1
t8 Select Ramp Time 1

The setting value:
 $1 \times 2_0 + 1 \times 2_1 + 1 \times 2_5 + 1 \times 2_6 = 99$
So Pd084 is set to 99.
Attach: $2_0=1$ $2_1=2$ $2_2=4$ $2_3=8$
 $2_4=16$ $2_5=32$ $2_6=64$ $2_7=128$

Pd085 is the last 8-step ramp time selection (the calculation method is same as Pd084).

Pd086	Frequency 2	Factory Setting	15
Pd087	Frequency 3	Factory Setting	20
Pd088	Frequency 4	Factory Setting	25
Pd089	Frequency 5	Factory Setting	30
Pd090	Frequency 6	Factory Setting	35
Pd091	Frequency 7	Factory Setting	40
Pd092	Frequency 8	Factory Setting	0.50
Pd093	Frequency 9	Factory Setting	10
Pd094	Frequency 10	Factory Setting	15
Pd095	Frequency 11	Factory Setting	20
Pd096	Frequency 12	Factory Setting	25
Pd097	Frequency 13	Factory Setting	30
Pd098	Frequency 14	Factory Setting	35
Pd099	Frequency 15	Factory Setting	40
Pd100	Frequency 16	Factory Setting	45
Set Range: 0.00—400.00 Hz		Unit: 0.01 Hz	

This parameter is set in combination of the multi-inputs to select 4-speeds of external control, multi-speeds of external control or multi-speeds of internal control.

For the relevant parameters, refer to the description of Pd080, Pd086-Pd100.

Pd101	Timer 1	Factory Setting	10.0
Pd102	Timer 2	Factory Setting	10.0
Pd103	Timer 3	Factory Setting	0.0
Pd104	Timer 4	Factory Setting	0.0
Pd105	Timer 5	Factory Setting	0.0
Pd106	Timer 6	Factory Setting	0.0
Pd107	Timer 7	Factory Setting	0.0
Pd108	Timer 8	Factory Setting	0.0
Pd109	Timer 9	Factory Setting	0.0
Pd110	Timer 10	Factory Setting	0.0
Pd111	Timer 11	Factory Setting	0.0

Pd112	Timer 12	Factory Setting	0.0
Pd113	Timer 13	Factory Setting	0.0
Pd114	Timer 14	Factory Setting	0.0
Pd115	Timer 15	Factory Setting	0.0
Pd116	Timer 16	Factory Setting	0.0
Set Range: 0.0—6500.0S		Unit: 0.1S	

This parameter is set for the internal control multi-speeds and the running time of drawing function.

For the relevant parameter, refer to Pd080, Pd101~Pd116.

Pd117	Auto PLC Memory Function	0-1	Factory Setting: 0
-------	--------------------------	-----	--------------------

0: Not memorized

1: Memorized

This parameter is set to determine whether the inverter is to realize the suspending function in Auto PLC mode. In case of Pd117=1, it can memorize the status in which the inverter is running and will memorize it at stop or fail. It will continue to run when returning to normal. In case of Pd117=0, it will not memorize.

Pd118	Over-voltage Stall Prevention	Set Range: 0-1	Unit: 1	Factory Setting: 1
-------	-------------------------------	----------------	---------	--------------------

0: Over-voltage stall prevention invalid

1: Over-voltage stall prevention valid.

When the inverter is in deceleration, due to the effect of load inertia, the motor will produce a return energy to the inverter and cause the DC voltage of the inverter to increase. So when the function of over-voltage stall prevention is started, if the DC voltage of the inverter becomes too high, the inverter will stop decelerating till the voltage at DC decreases below the set value, then the inverter will go on to decelerate and the ramp-down time will be extended automatically.

Pd119	Stall Prevention Level at Ramp-up	Set Range: 0-200%	Unit: 1%	Factory Setting: 150
-------	-----------------------------------	-------------------	----------	----------------------

When the inverter is in ramp-up, due to overload or too short ramp-up time, the output current of the inverter will go up quickly and exceed the set standard level. When this happens, the inverter will stop accelerating. When the current returns under its set value, the inverter will go on to accelerate.

100% current is the rated current of the motor. When this parameter is set to 0, the stall prevention function is invalid.

Pd120	Stall Prevention Level at Constant Speed	Set Range: 0-200%	Unit: 1%	Factory Setting: 0
-------	--	-------------------	----------	--------------------

When the inverter is running at constant speed, due to load fluctuation and other reasons, the current will increase. When the current exceeds its set standard value, the inverter will lower the output frequency. When the output current returns to its normal range, the inverter will accelerate again to its set frequency.

100% current is the rated current of the motor. When this parameter is set to 0, the stall prevention function is invalid.

Pd121	Decel. Time for Stall Prevention at Constant Speed	Factory Setting: 5.0
-------	--	----------------------

When the inverter is used for the loads of kinds of fan and pump, Pd119 can be set to 120. When the current of the inverter is greater than 120%, the output frequency will decrease and the current will also decrease accordingly. After the current returns to normal, the frequency will return to normal slowly, so as to achieve the stall prevention function. The decreasing speed of the frequency is determined by Pd119. For the related parameters, refer to Pd119.

Pd122	Stall Prevention Level at Deceleration	Set Range: 0-200%	Unit: 1	Factory Setting: 150
-------	--	-------------------	---------	----------------------

Please refer to Pd120.

100% current is the rated current of the motor.

Pd123	Over-torque Detect Mode	Set Range: 0-3	Unit: 1	Factory Setting: 0
-------	-------------------------	----------------	---------	--------------------

0: When reaching the frequency, it starts to detect over-torque and when over-torque is detected, it continues to run.

1: When reaching the frequency, it starts to detect over-torque and when over-torque is detected, it stops running.

2: It detects over-torque during running and when over-torque is detected, it continues to run.

3: It detects over-torque during running and when over-torque is detected, it stops running.

Pd124	Over-torque Detect Level	Set Range: 0-200%	Unit: 1%	Factory Setting: 0
-------	--------------------------	-------------------	----------	--------------------

When the output current exceeds the over-torque detection level and also exceeds half of the set time of over-torque detection (factory setting: 1.0s), the over-torque detection will indicate, and the corresponding multi-function alarm contact will act. When it exceeds the set time, the inverter will turn to self-protection. When this parameter is set to 0, the over-torque detection will be invalid.

Pd125	Over-torque Detect Time	Set Range: 0.1-20.0S	Unit: 0.1S	Factory Setting: 1.0
-------	-------------------------	----------------------	------------	----------------------

When the inverter detects that the output current has exceeded the motor current set value, the inverter begins to calculate the over-torque time. When the over-torque time has exceeded half of the set detect time, the corresponding multi-function output contact will act, and produce the over-torque alarm, while the inverter will keep running. When the over-torque time has exceeded the set detect time (set by Pd125), the inverter will turn to self-protection, display the fault information and stop output. For the related parameters, refer to Pd123.

Pd126	Counter Memory
-------	----------------

Set Range: 0-1	Unit: 0	Factory Setting: 0
----------------	---------	--------------------

0: Not memorize

1: Memorize

Counter memory , inverter memory function

Pd127-Pd129

Reserved

Pd130

Number of Auxiliary Pump

Set Range: 0-2

Unit: 1

Factory Setting: 0

This parameter is set for the number of auxiliary pump. The start or stop of the auxiliary pumps is controlled by using the multi-output contacts and Auxiliary Pump 1 or Auxiliary Pump 2 is controlled through the peripheral control circuit.

Pd131	Continuous Running Time of Auxiliary Pumps
-------	--

Set Range: 0-900(min)

Unit: 1

Factory Setting: 60

In case of two pumps with only one pump in duty, in order to ensure each pump to work evenly, it will be switched to another pump when its running time reaches the set value of Pd131.

Pd132	Interlocking Time of Auxiliary Pump
-------	-------------------------------------

Set Range: 1-250S

Unit: 1

Factory Setting: 5S

This parameter is set to determine the interlocking time of two auxiliary pumps when switching with each other.

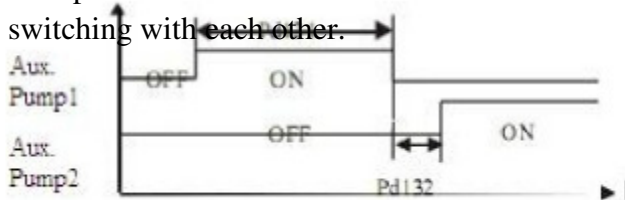

Pd133	High Speed Running Time
-------	-------------------------

Set Range: 1-250S

Unit: 1

Factory Setting: 60S

In the application of water supply with constant pressure, when the master pump is running at the frequency of high speed (set by Pd060) due to larger water volume and the high speed running time is reached, the corresponding multi-function contacts act and the auxiliary pumps start.

Pd134	Low Speed Running Time
-------	------------------------

Set Range: 1-250S

Unit: 1

Factory Setting: 60S

In the application of water supply with constant pressure, when the master pump is running at the frequency of low speed (set by Pd061) due to smaller water volume and the low speed running time (Pd134) is reached, the corresponding multi-function contacts act and the auxiliary pumps stop.

Pd133 and Pd134 must be used in combination of Pd060, Pd061 and multi-outputs.

Their main function is to increase or decrease the number of auxiliary pump.

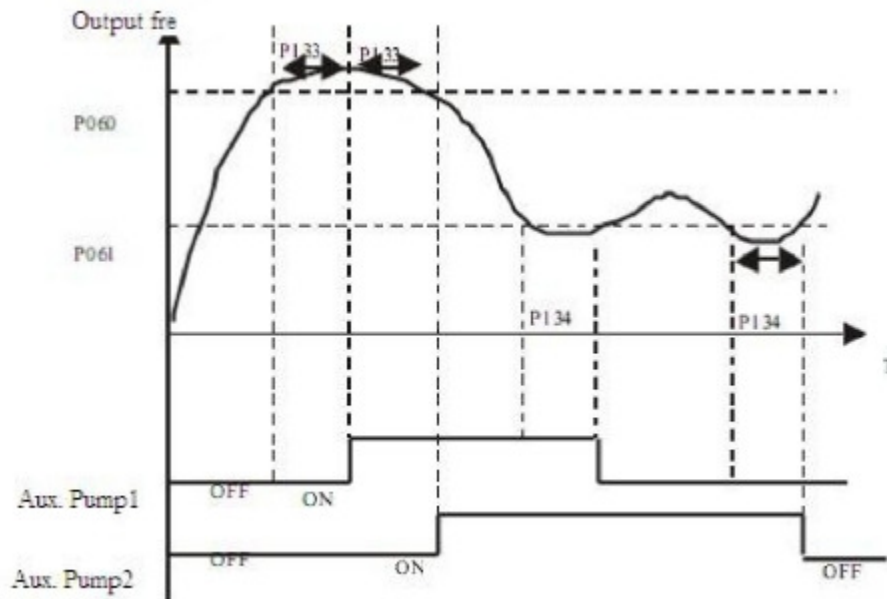

Pd135	Stopping Voltage Level	Unit: 1	Factory Setting: 95%
	Set Range: 0-150%		

This parameter is set for the voltage level of the master pump entering into sleep mode. For details, refer to the following description.

Pd136	Lasting Time of Stopping Voltage Level	Unit: 1	Factory Setting: 30S
	Set Range: 1-250S		

This parameter is set for the lasting time under the stopping voltage level before entering into sleep mode.

Pd137	Wakeup Voltage Level	Unit: 1	Factory Setting: 80%
	Set Range: 0-150%		

This parameter is set for the wakeup voltage level from sleep to wakeup.

Pd138	Sleep Frequency	Unit: 1	Factory Setting: 20.0
	Set Range: 0.00-400.00		

This parameter is set for the lowest operating frequency entering into sleep mode.

Pd139	Lasting Time of Sleep Frequency	Unit: 1	Factory Setting: 20S
	Set Range: 1-250S		

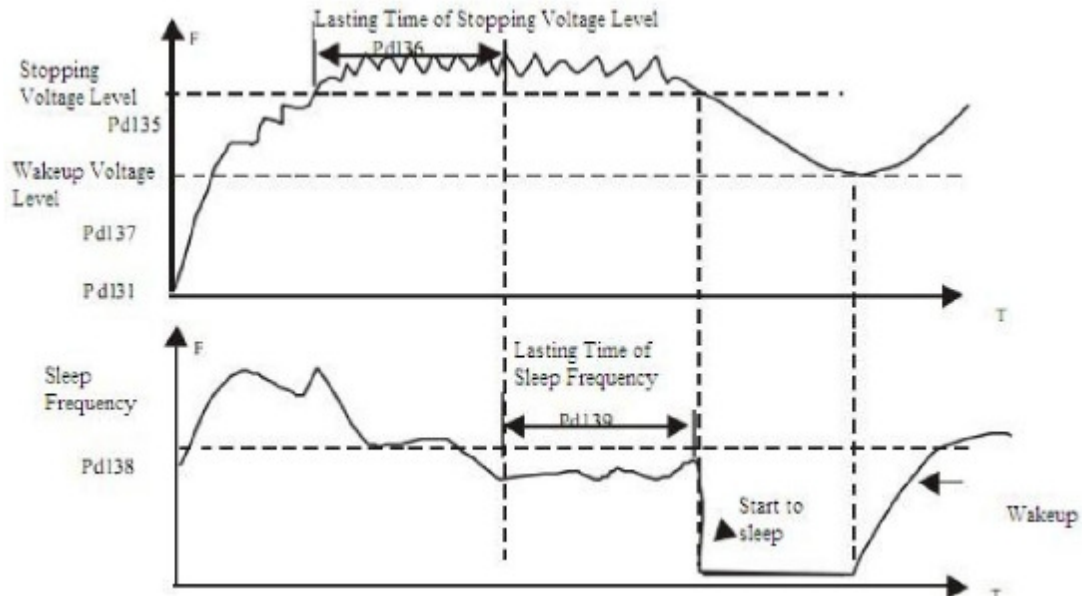

This parameter is set for the lasting time to run at sleep frequency when entering into sleep mode.

Pd140	Reserved
-------	----------

Pd141	Rated Motor Voltage	Unit: 0.1V	Factory Setting: *
-------	---------------------	------------	--------------------

It is set according to the rated voltage value of the nameplate of the motor. For the inverters of 230V class, the factory setting is 220, while for the inverters of 400 V class, the factory setting is 380.

Pd142	Rated Motor Current	Unit: 0.1A	Factory Setting: *
-------	---------------------	------------	--------------------

It is set according to the rated value of the nameplate of the motor. This parameter can be used to restrict the output current of the inverter to prevent over-current and protect the motor. If the current of the motor has exceeded this value, the inverter of AC motor will turn to self-protection.

Pd143	Motor Pole Number	Set Range: 02-10	Unit: 1	Factory Setting: 04
-------	-------------------	------------------	---------	---------------------

This parameter is set for the number of the motor's pole according to the nameplate of the motor.

Pd144	Rated Motor Revolution	Set Range: 0-9999	Unit: 1r/min	Factory Setting: 1440
-------	------------------------	-------------------	--------------	-----------------------

This is set according to the actual revolution of the motor. The displayed value is the same as this set value. It can be used as a monitoring parameter, which is convenient to the user. This set value corresponds to the revolution at 50Hz.

Pd145	Auto Torque Compensation	Set Range: 0.1-10.0%	Unit: 0.1%	Factory Setting: 2.0%
-------	--------------------------	----------------------	------------	-----------------------

This parameter can be set for the auto output of extra voltage when the inverter is running to a higher torque, which can compensate for the under-torque at lower frequency. The torque compensation should not be too big and it should be set slowly from low to high according to the actual situation. Insufficient compensation will result in the under-torque of the motor at lower frequency. And over compensation will lead to too bigger torque, which will produce a shock to the machine and even result in a trip of the inverter under serious situation.

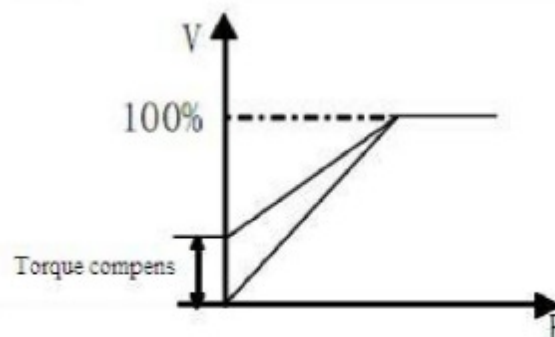

Pd146	Motor No-load Current	Unit: 1	Factory Setting: 40
	Set Range: 0-99		

The setting of motor no-load current will affect the value of slip compensation. The current is 100% of the rated current of the motor.

Pd147	Motor Slip Compensation	Unit: 0.1	Factory Setting: 0.0
	Set Range: 0.0-10.0		

When the inverter drives the motor, the slip becomes bigger due to the increase of load. This parameter can be set for slip compensation to decrease the slip and make the running speed of the motor closer to the synchronous revolution.

Pd148-Pd149	Reserved		
-------------	----------	--	--

Pd150	Auto Voltage Regulation (AVR)	Unit: 1	Factory Setting: 1
	Set Range: 0-1		

0: Invalid 1: Valid

When the input power is not stable and if the voltage is too high, the operation of the motor with the power exceeding the rated voltage will cause increase of the temperature of the motor, damage of its insulation and unstable output torque. This auto voltage regulation can automatically stabilize the output voltage within the rated voltage range of the motor under the condition of unstable output power supply. When this function is set to invalid, the output voltage will fluctuate.

Pd151	Auto Energy Saving	Unit: 1%	Factory Setting: 0
	Set Range: 0-10%		

When it is set to zero, this function is invalid. When auto energy saving function is started, the inverter will run at the full voltage during ramp-up or -down. During the operation at constant speed, the inverter can automatically calculate the optimum voltage value according to the power of load and supply power to the load to achieve the goal of energy saving.

Pd152	Fault Restart Time	Factory Setting: 0
-------	--------------------	--------------------

When the inverter is set for fault restart and if it has a fault trip with the time exceeding the set value of Pd152, the inverter will restart. When using this function, pay more attention to the safety.

Pd153	Restart after Instantaneous Stop	Unit: 1	Factory Setting: 0
	Set Range: 0-1		

0: Invalid, i.e. the inverter will not restart after an instantaneous power breakdown.
1: Start by frequency track. Refer to Pd025.

Pd154	Allowable Power-Breakdown Time	Unit: 0.1S	Factory Setting: 0.5
	Set Range: 0.1-5.0S		

This parameter is set for the maximum allowable power failure time. If exceeding the set time, the inverter will continue to stop output after power on.

To restart the inverter, it needs to follow the general starting procedures.

Pd155	Number of Abnormal Restart	Unit: 1	Factory Setting: 00
	Set Range: 00-10		

After the abnormal conditions (such as over-current and over-voltage) happens, the inverter will automatically reset and restart. If the starting mode is set to normal mode, it will start according to the normal procedures. If it is set to start by frequency track, it will start in the frequency track mode. After starting, it will restore the set number again if there is no more abnormality happened within 60 seconds. If there is still any error and it reaches the set number, the inverter will stop output. It can only be started after reset. When Pd155 is set to zero, the inverter will not carry out the functions of automatic reset and restart.

Pd156	Proportional Constant (P)	**
	Set Range: 0.0~100.00%	Unit: 0.1% Factory Setting: 100%

This proportional constant is set for the error value gain. In case of I=0, D=0, it is only for proportional control.

Pd157	Integral Time (I)	**
	Set Range: 0.1~3600.0S	Unit: 0.1S Factory Setting: 5.0S

The integral time (I) is set for the responding speed for PID. The larger the I value is set, the slower the responding speed will be. To the contrary, if the responding speed is quick but the integral time value is set too small, it will cause oscillation.

Pd158	Differential Time (D)	**
	Set Range: 0.1~10.00S	Unit: 0.01S Factory Setting: 0

This differential time (D) is set for the depression operation of PID. The larger the D value is, the more obvious the depression operation will be. When D is set to zero, this function is invalid.

Pd159	Target Value Set Range: 0~100.0%	** Unit: 1% Factory Setting: *
-------	-------------------------------------	-----------------------------------

This target value can be set through external voltage signal or the digital operator.
100% target value is corresponding to the analog frequency at +10V.

PID closed-loop control is usually used in the process control with physical quantity not changing fast, such as the controls of pressure and temperature, etc. The feedback signal is usually taken from temperature transmitter, or pressure transmitter, etc.

Under PID control, the feedback signal input path is the analog current signal of 4-20mA.

PID closed-loop control is valid when Multi-input PID is started.

PID Control Block Diagram:

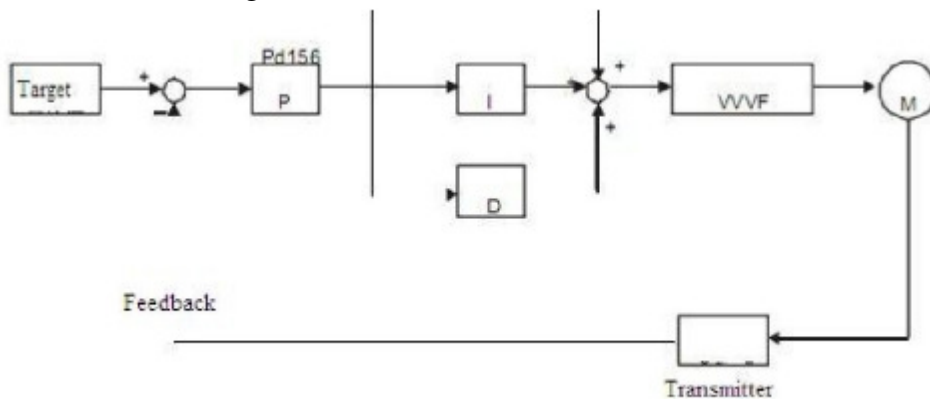

General operating methods of PID control:

- (1) Choose the correct transmitter (with the output specification of standard current signal 4-20mA)
- (2) Set the right target value.
- (3) If the output does not have oscillation, increase the proportional constant (P).
- (4) If the output does not have oscillation, decrease the integral time (Ti)
- (5) If the output does not have oscillation, increase the differential time (Td).
- (6) Concrete applications can be referred to the example application descriptions in Appendix 1.

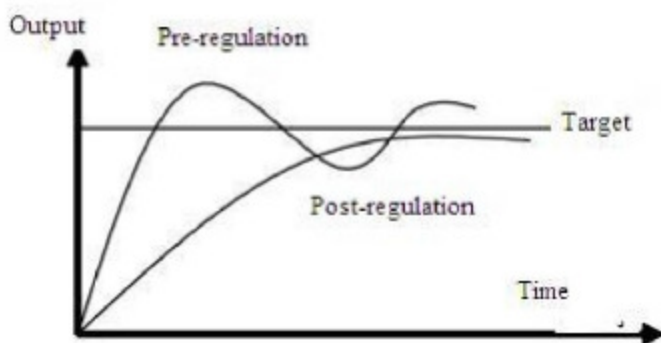

1. Suppress the Over Output
 - a: Decrease the differential time (D value)
 - b: Increase the integral time (I value)

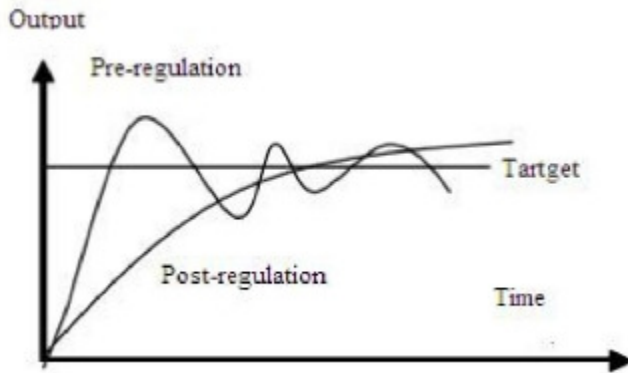

2. Suppress the oscillation

- a: Decrease the differential time (D value) or set it to zero.
- b: Decrease Proportional Constant (P value)

Pd160	PID Target Value	**
	Set Range: 0-1	Unit: Factory Setting: 0

The target value can be set through the selection of the panel or external analog. The external analog is 0~10V signal or given by the potentiometer.

When Pd160=0, the target value of PID is the value set by Pd159.

When Pd160=1, the target value of PID is the value of the external analog 0-10V (corresponding to 0-100%), the setting of Pd159 is invalid.

Pd161	PID Upper Limit	**
	Set Range: 0~100%	Unit: Factory Setting: 100%

When PID feedback value is more than the set value of Pd161, the corresponding multi-output will act and the inverter will not stop.

Pd162	PID Lower Limit	**
	Set Range: 0~100%	Unit: Factory Setting: 0%

When PID feedback value is less than the set value of Pd162, the corresponding multi-output will act and the inverter will not stop.

Pd163	Communication Addresses	
	Set Range: 00-250	Unit: Factory Setting: 00

When the inverter is set for RS-485 Communication interface control, each of the inverters will be set for its individual identification number.

00: No communication function.

01~250: Address for the inverters

Pd164	Communication Band Rate	
	Set Range: 0-3	Unit: Factory Setting: 1

0: 4800 b/s 1: 9600 b/s 2: 19200 b/s 3: 38400 b/s

Pd165	Communication Data Method	
	Set Range: 0-5	Unit: 1 Factory Setting: 0

0: 8N1 For ASCII 1: 8E1 For ASCII 2: 8O1 For ASCII
 3: 8N1 For RTU 4: 8E1 For RTU 5: 8O1 For RTU

Pd166-Pd168	Reserved	
-------------	----------	--

MODBUS Communication Protocol

1. ASCII mode:

Mode of communication data

STX “:” (3AH)	ADDRESS	CMDFUNC	DataH	DataL	LRC	END CR (0DH) LF (0AH)
---------------------	---------	---------	-------	-------	-----	-----------------------------

(1) STX Starting unit " : " (3AH)

(2) ADDR communication address, 8-bit data is composed of two ASCII bytes.

01~250: Address of the corresponding inverters.

(3) CMDFUNC: Function code 8-bit command

- 01 Read the single code data
- 03 Read register
- 04 Read input register
- 05 Write the single code data status
- 06 Write the single register
- 0F Write multi- code data status
- 10 Write multi-register

a: Read function code data

Send the data format:

“:” ADDRESS 01 ADDRH ADDRL NUMH NUML LRC 0X0D 0X0A

Note: ADDR: 0X0000--- 0X FFFF; NUM: 0X0001---0X 0020 (NUM means the number of code data to be read)

The format of normal returned data:

“:” ADDRESS 01 BYTECOUNT DATA1 DATA2 DATA3 DATAN LRC 0X0D 0X0A

Note: BYTECOUNT = NUM/8 or BYTECOUNT = NUM/8 + 1 (taken as a whole or whole +1)

Format of wrong returned data:

“:” ADDRESS 0X81 01 or 02 or 03 or 04 LRC 0X0D 0X0A

eg. Read the status of current running of the inverter

ASII format

Send: 3A 30 31 30 30 30 35 30 30 30 31 3F 39 0D 0A

Return: 3A 30 31 30 31 30 31 30 31 46 43 0D 0A (ASII)

The returned data bite “01” (hexadecimal) is converted into 2-byte “0000 0001”, the last one means the running status; “1” means the inverter is under REV. running (“0” for FOR. Rotation or STOP, refer to specific description)

b. 03 read data register

Send the data format:

“:” ADDRESS 03 ADDRH ADDRL NUMH NUML LRC 0X0D 0X0A

Note: ADDR: 0--- 0XFFFF; NUM: 0X0001---0X 0020 (NUM means the number of data register to be read)

The format of normal returned data:

“:” ADDRESS 03 BYTECOUNT DATA1 DATA2 DATA3 DATAN LRC 0D 0A

Note: BYTECOUNT = 2 * NUM

Format of wrong returned data:

“:” ADDRESS 0X83 01 or 02 or 03 or 04 LRC 0X0D 0X0A

eg. Read the value of function code in Pd003 (eg. 30.00Hz)

RTU Format send: “:” 03 00 00 00 00 01 FC 0D 0A (hexadecimal)

ASCII Format send: 3A 30 33 30 30 30 30 30 30 30 3A 46 43 0D 0A (ASCII)

RTU Format data returned: “:” 01 03 02 0B B8 37 0D 0A (hexadecimal)

ASCII Format data returned: 3A 30 31 30 33 30 32 30 42 42 38 33 37 0D DA

The bite of data returned “0BB8” (hexadecimal) means P003 = 30.00

c. 04 read input data register

Send the data format:

“:” ADDRESS 04 ADDRH ADDR L NUMH NUML LRC 0X0D 0X0A

Note: ADDR: 0--- 0XFFFF; NUM: 0X0001---0X 0004 (NUM means the number of code data to be read)

The format of normal returned data:

“:” ADDRESS 04 BYTECOUNT DATAH1 DATAL1 – DATAHN DATALN

Note: BYTECOUNT = NUM * 2

Format of wrong returned data:

“:” ADDRESS 0X84 01 or 02 or 03 or 04 LRC 0X0D 0X0A

eg. The current temperature of the inverter

RTU Format send: “:” 01 04 00 06 00 01 F4 0D 0A

ASCII Format send: 3A 30 31 30 34 30 30 30 36 30 30 30 31 46 34 0D 0A

RTU data returned: 01 04 02 01 6A 8E 0D 0A

ASCII data returned: 3AC 30 31 30 34 30 32 30 31 36 41 38 45 0D 0A

The bite of data returned is 0x16A, means the temperature is 36.2

d. Write single data status

Send the data format:

“:” ADDRESS 05 ADDRH ADDR L NUMH NUML LRC 0X0D 0X0A

Note: ADDR: 0--- 0XFFFF DATA: 0X0000 or 0XFF00 (0XFF00 valid)

The format of correct returned data:

“:” ADDRESS 05 ADDRH ADDR L DATAH DATAL LRC 0X0D 0X0A

The format of wrong returned data:

“:” ADDRESS 0X85 01 or 02 or 03 or 04 LRC 0X0D 0X0A

eg. Inverter running through communication control

Data sent through RTU: 01 05 00 48 FF 00 B3 “0D 0A” (hexadecimal)

Data sent through ASCII: 3A 30 31 30 35 30 30 34 38 46 46 30 30 42 33 0D 0A
(ASCII)

Data returned through RTU: 01 05 00 48 FF 00 B3 “0D 0A” (hexadecimal)

Data returned through ASCII: 3A 30 31 30 35 30 30 34 38 46 46 30 30 42 33 0D 0A
(ASCII)

e. 06 Write single data register

Send the data format:

“:” ADDRESS 06 ADDRH ADDRL DATAH DATAL LRC 0X0D 0X0A

Note: ADDR: 0--- 0XFFFF

Correct returned data:

“:” ADDRESS 06 ADDRH ADDRL DATAH DATAL LRC 0X0D 0X0A

Wrong returned data:

“:” ADDRESS 0X86 01 or 02 or 03 or 04 LRC 0X0D 0X0A

eg. Write 1.84Hz into inverter P003

Data sent through RTU: 01 06 00 03 00 B8 36 0D 0A (hexadecimal)

Data sent through ASCII: 3A 30 31 30 36 30 30 30 33 30 30 42 38 33 45 0D 0A
(ASCII)

Data returned through RTU: 01 06 00 03 00 B8 79 B8 (hexadecimal)

Data returned through ASCII: 3A 30 31 30 36 30 30 30 33 30 30 42 38 33 45 0D 0A
(ASCII)

The bite of data returned is “00BB” (hexadecimal), means the setting for P003 is 1.84.

f. 0F Write multi-data status

Send the data format:

“:” ADDRESS 0F ADDRH ADDRL NUMH NUML COUNT DATAH1 DATAL1
DATA2H DATA2L – DATANH DATANL LRC 0X0D 0X0A

Note: ADDR: 0X000 – 0X00FF; DATA: 0X0000 ~ 0X00FF

NUM: 0X0000 – 0X0007; COUNT: NUM/8 or NUM/8 + 1 (NUM means the number
of data to be written)

The format of correct returned data:

“:” ADDRESS 0F ADDRH ADDRL NUMH NUML LRC 0X0D 0X0A

The format of wrong returned data:

“:” ADDRESS 0X8F 01 or 02 or 03 or 04 LRC 0X0D 0X0A

eg. Send REV. rotation and running command to the inverter at the same time

Data sent through RTU: 01 0F 00 48 00 03 01 00 05 9F 0D 0A (hexadecimal)

Data sent through ASCII: 3A 30 31 30 46 30 30 34 38 30 30 30 33 30 31 30 30 30 35
39 46 0D 0A

Data returned through RTU: 01 0F 00 48 00 03 A5 0D 0A (hexadecimal)

Data returned through ASCII: 3A 30 31 30 46 30 30 34 38 41 35 0D 0A (ASCII)

g. 10 Write multi-data register

Send the data format:

“:” ADDRESS 0x10 ADDRH ADDRL NUMH NUML BYTECOUNT DATAH1
DATAL1 DATA2H DATA2L – DATANH DATANL LRC 0X0D 0X0A

NUM: 0X0000 – 0X0000 – 0XFFFF; NUM: 0X000-0X00FF (NUM means the
number of data register)

BYCOUNT = NUM * 2

The format of correct returned data:

“:” ADDRESS 0x10 ADDRH ADDRL NUMH NUML LRC 0X0D 0X0A

The format of wrong returned data:

“:” ADDRESS 0X90 01 or 02 or 03 or 04 LRC 0X0D 0X0A

If 1.84 is input into Pd003 and 0.2 into Pd004 simultaneously

Data sent through RTU: 01 10 00 00 00 02 04 0B B8 00 02 D6 0D 0A (hexadecimal)

Data sent through ASCII: 3A 30 31 31 31 30 30 30 33 30 30 32 30 34 30 30 42 38 30 30 30 32 32 43 0D 0A (ASCII)

Data returned through RTU: 01 10 00 03 00 02 B1 C8 0D 0A (hexadecimal)

Data returned through ASCII: 3A 30 31 31 30 30 30 33 30 30 30 32 45 41 0D 0A (ASCII)

The data sent to be input into 16-byte data “0x00b8” AND “0x02” means 1.84 and 0.2 are input respectively.

Wrong communication codes:

01 Illegal function code

02 Illegal data address

03 Illegal data

04 Device failures

Introduction of function codes

Introduction of function data codes

Data	Description	R/W	Note
0000	Reserved	R	
0001	Reserved	R	
0002	Reserved	R	
0003	Running	R	0-Stop 1-Run
0004	Jogging	R	0 -Invalid 1 -Jogging
0005	FOR./REV. Rotation	R	0-FOR 1-REV
0006	Braking	R	0 -Invalid 1 -Brake P02-00=0
0007	Frequency track	R	0-Invalid 1-Frequency track P02-00=0
0008	IGBT Short circuit	R	0 -Invalid1 -Error ‘OC’
0009	CT over-current detect high	R	0 -Invalid1 -Error ‘OC’
000A	CT over-current detect low	R	0 -Invalid1 -Error ‘OC’
000B	Earth short circuit	R	0 -Invalid1 -Error ‘GF’
000C	Over-voltage	R	0 -Invalid1 -Error ‘OU’
000D	Fuse break	R	0 -Invalid1 -Error ‘FB’
000E	Low-voltage	R	0 -Invalid1 -Error ‘LU’
000F	Inverter over-heating	R	0 -Invalid1 -Error ‘OH’
0010	Inverter over-load	R	0 -Invalid1 -Error ‘OL’
0011	Motor over-load	R	0 -Invalid1 -Error ‘OA’
0012	Motor over-torque	R	0 -Invalid1 -Error ‘OT’
0013	Connector fault	R	0 -Invalid1 -Error ‘LU’
0014	Braking pipe fault	R	0 -Invalid1 -Error ‘BT’
0015	CPU fault	R	0 -Invalid1 -Error ‘FE’

0016	Register fault	R	0 -Invalid 1 -Error 'BE'
0017	Master fault indication	R	0 -Invalid 1 -Error 'KE'
0018	Inverter over-load	R	0 -Invalid 1 -Alarm 'OL'
0019	Motor over-load	R	0 -Invalid 1 -Alarm 'OA'
001A	Motor over-torque	R	0 -Invalid 1 -Alarm 'OT'
001B	Temperature too high	R	0 -Invalid 1 -Alarm 'OH'
001C	Emergency stop	R	0 -Invalid 1 -Alarm 'ES'
001D	CRC inspection	R	0 -Invalid 1 -Alarm 'ER'
001E	4- 20MA break	R	0 -Invalid 1 -Alarm '20'
001F	Para setting wrong	R	0 -Invalid 1 -Alarm 'PR'
0020	Multi-input FB	R	0—Invalid 1 — Valid
0021	Multi-input MCS	R	0—Invalid 1 — Valid
0022	01Terminal input	R	0—Invalid 1 — Valid
0023	02Terminal input	R	0—Invalid 1 — Valid
0024	03Terminal input	R	0—Invalid 1 — Valid
0025	04Terminal input	R	0—Invalid 1 — Valid
0026	05Terminal input	R	0—Invalid 1 — Valid
0027	06Terminal input	R	0—Invalid 1 — Valid
0048	RUN	W	0000—Invalid FF00—Valid
0049	FOR	W	0000—Invalid FF00—Valid
004A	REV	W	0000—Invalid FF00—Valid
004B	STOP	W	0000—Invalid FF00—Valid
004C	F/R	W	0000—Invalid FF00—Valid
004D	JOG	W	0000—Invalid FF00—Valid
004E	JOGF	W	0000—Invalid FF00—Valid
004F	JOGR	W	0000—Invalid FF00—Valid

Introduction of data register code functions

The function code addresses are same as the parameters shown on the keyboard.

Introduction of input register code function addresses

Input register address	Description	R/W	Note
0000	Output frequency	R	
0001	Set frequency	R	
0002	Output current	R	
0003	Output rotation	R	
0004	DC voltage	R	
0005	AC voltage	R	
0006	Counter	R	
0007	Temperature	R	
0008	PID target value	R	
0009	PID feedback value	R	

4) DATA: data content: n x 8-bit

5) LRC:

ASCII mode: Get LRC methods is that add ADDR to the last data, if the result is more than 256, then the result subtract 256 until the result is less than 256 (if the result is 11128H, take 1128H), then 100H subtract the result to get LRC.

2. RTU mode

Quiet	ADDR	FUNCL	DATAH	DATAL	CRCH	CRCL	Quiet
> 50ms							> 50ms

CRC calculating method of the check codes is the same as that of CRC.

Eg. Write 30.00Hz to inverter of 03

ADDR	FUNCL	DATAH(ADDRESS)	DATAL(ADDRESS)	DATAH	DATAL	CRCH	CRCL
01H	06H	00H	03H	0BH	B8H	8EH	88H

Sent data: 01H 06H 00H 03H 0BH B8H 8EH 88H

Pd170	Display Items	Unit: 1	Factory Setting: 0
	Set Range: 0-5		

This parameter is only valid when Bit 2 is set to 1 in CD168.

For the details, refer to Pd171.

- 0: Inverter Temperature
- 1: Counter Value
- 2: PID Target Value
- 3: PID Feedback Value

Pd171	Display Items Open	Unit: 1	Factory Setting: 0
	Set Range: 0-15		

This parameter is set for selection of displaying of DC voltage, AC voltage and other items, so that the customer can monitor and view them in sequence through the switch key.

It can be set first in the binary 3 bits mode, and then converted to a decimal value.

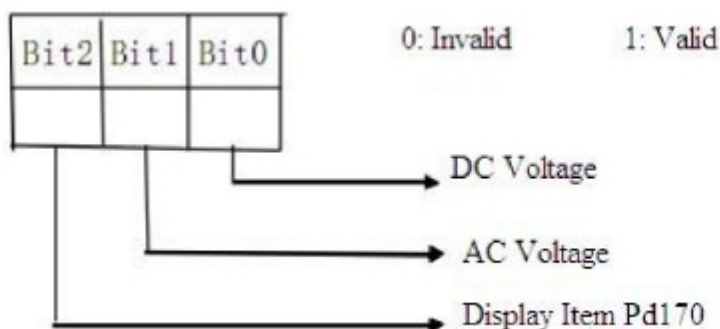

In the contents displayed the factory setting is to show output frequency, set frequency, output current and output revolution through the switch key. If it is necessary to view

and monitor other items, they can be set through Pd170 and Pd171.

Pd172	Fault Clear Set Range: 00-10	Unit: 1 Factory Setting: **
-------	---------------------------------	-----------------------------

01 is for fault clear. Others have no function.

Pd173	Inverter Voltage Class	Unit: 1V Factory Setting: *
-------	------------------------	-----------------------------

It is factory setting, and is decided by the model. It can be observed, but not set.

Pd174	Inverter Current Class	Unit: 1A Factory Setting: *
-------	------------------------	-----------------------------

It is decided by the model and can not be changed.

Pd175	Inverter Model Set Range: 0-1	Unit: 1 Factory Setting: 0
-------	----------------------------------	----------------------------

0: Constant torque 1: For kinds of fan. It can be observed, but not changed.

Pd176	Inverter Frequency Standard	Unit: 1 Factory Setting: *
-------	-----------------------------	----------------------------

0: 50Hz 1: 60Hz It is factory setting. It can be observed, but not set.

Pd177	Fault Record 1	Factory Setting: -----
Pd178	Fault Record 2	Factory Setting: -----
Pd179	Fault Record 3	Factory Setting: -----
Pd180	Fault Record 4	Factory Setting: -----

When it has no fault record it shows ----. After access to this parameter, the fault display can be checked.

Pd181	Software Version	Factory Setting: *
-------	------------------	--------------------

It can be observed, but not set.

Pd182	Manufacture Date	Factory Setting: *
-------	------------------	--------------------

It is factory setting. It can be observed, but not set.

Pd183	Serial No.	Factory Setting: *
-------	------------	--------------------

It is factory setting. It can be observed, but not set.

Pd183~Pd250 Factory Setting		
-----------------------------	--	--

Note: * means the said parameter has a variety of set values or should be set specifically according to concrete conditions

** means the said parameter can be set during the operation.

X. Care & Maintenance, Fault Information and Troubleshooting

Periodical maintenances and inspections will keep your inverter in its normal state for long time.

1. Precautions about Inspection and Maintenance

- Be sure to turn off the power supply to the inverter (R.S.T) first before the inspection and maintenance.
- After confirming the main circuit power supply has been turned off and the display has disappeared, wait until the internal indicator lamp for high voltage goes out before performing the inspection and maintenance.
- During the inspection, do not pull out or wrongly distribute the internal power supply, wires and cables. Otherwise it will cause malfunction or damage to the inverter.
- Do not leave any screw or other part inside the inverter during the installation, or it will result in the short circuit of circuit board.
- Keep the inverter clean, free from dust, oil mist and moisture after the installation.

2. Periodical Inspection and Maintenance items

- Check whether the power supply voltage conforms to the rated voltage of the inverter.
(Pay special attention to that whether there is any damage on the power supply wires and the motor.)
- Check whether the wiring terminals and the connectors are tight.
(Check whether the power supply wires and terminal connection wires have any broken strand).
- Check whether there is dust, iron filings or corrosive fluid in the inverter.
- Measuring the insulation impedance of the inverter is forbidden.
- Examine the output voltage, output current and output frequency of the inverter.
(The measuring results should not have too big difference.)
- Check whether the ambient temperature of the inverter is between -5°C and 40°C and whether the installation environment has good ventilation.
- Check whether the humidity is kept below 90% (without condensation).
- Check whether the motor makes unusual noises or abnormal vibration in running.
(The inverter should not be installed in a place with high vibration.)
- Please make periodical cleaning of vent holes.

3. Fault Indication and Troubleshooting

The inverter of RLP series is relatively perfective with the protection functions of overload, inter-phase short circuit, earth short circuit, under-voltage, overheating and over-current, etc. When a protection function happens with the inverter, please check the reasons of faults according to the information listed in the table below. The inverter can be restarted after the disposal. If the fault cannot be disposed, please

contact the local distributor.

Fault Display	Fault Contents & Description	Disposal methods
E.OC.A	Over-current during ramp-up	1: Check whether the motor has got short circuit or partial short circuit and whether the insulation of output wire is good. 2: Extend the ramp-up time. 3: The configuration of the inverter is not reasonable. The inverter's capacity should be increased. 4: Decrease the torque and increase the set value.
E.OC.n	Over-current at constant speed	1: Check whether the motor has got short circuit and whether the insulation of the output wires is good. 2: Check whether the motor is blocked and whether there is a sudden change of mechanical load. 3: Check whether the inverter's capacity is too small and increase its capacity. 4: Check whether there is a sudden change in the power supply voltage.
E.OC.d E.OC.S	Over-current at decel Over-current at stop	1: Check whether the insulation of the output wires is good and whether the motor has got short circuit. 2: Extend the Ramp-down Time. 3: Replace it with an inverter of larger capacity. 4: DC braking is too high. Decrease DC braking. 5: The inverter has failure. Please send it to the factory for repair.
GF	Short circuit	1: Check whether the connection wire of the motor has got short circuit. 2: Check whether the insulation of the output wires is good. 3: Please send it for repair.
E.OU.S E.OU.a E.OU.n E.OU.d	Over-voltage at stop Over-voltage at accel Over-voltage at constant speed Over-voltage at decel	1: Extend the Ramp-down Time or add a braking resistor. 2: Improve the mains supply voltage and check whether there is any sudden change in the voltage.
Fb	Fuse break	The fuse breaks. Please send it for repair.

OH	Overheat of Inverter	1: Check whether the fan is blocked and whether there is any foreign matter stuck in the cooling fins. 2: Check whether the ambient temperature is normal. 3: Check whether there is enough space for ventilation and good air convection.
OL	Inverter overload, 150% per 1min	1: Check whether the capacity of the inverter is lower. Otherwise it should be increased. 2: Check whether there is any jamming in the mechanical load. 3: The setting of V/F curve is bad. Set it again.
OA	Motor overload, 150% per 1min	1: Check whether there is any sudden change in the mechanical load. 2: The equipped motor is too small. 3: The motor is hot and the insulation becomes bad. 4: Check whether the voltage has big fluctuation. 5: Check whether there is any phase missing. 6: The mechanical load is increased.
OT	Motor over-torque	1: Check whether there is any fluctuation in the mechanical load. 2: Check whether the equipped motor is smaller.

Er	External interference	Isolate the interference source
ES	Emergency Stop	In Emergency Stop
20	4-20mA wire broken	Join the broken wire
Pr	Setting error	Correct the setting
DCb	DC brake status	In DC braking

Code Comparison Table:

A	B	C	D	E	F	G	H	O	S	N	L	T	P	R	U	2
R	b	c	d	e	f	g	h	o	s	n	l	t	p	r	u	2

4. Faults and Analysis

(1) When RUN key is pressed, the motor does not run.

- 1) The setting of operation mode is wrong, i.e., under the operation mode of external control terminals, the inverter is started by the digital operator or under the operation mode of the digital operator; it is started by the external control terminals.

- 2) The frequency reference is too low or not set.
 - 3) The peripheral wiring is wrong. For example, the setting of wiring of two-wire system and three-wire system and other related parameters have errors.
 - 4) The setting of multi-function terminals is wrong (in the external control).
 - 5) The inverter is in the fault protection.
 - 6) The motor fails.
 - 7) The inverter fails.
- (2) The parameters cannot be set.
- 1) Password locks. Please decrypt it first before resetting.
 - 2) The inverter is in running.
 - 3) The connection of the connecting parts is abnormal. The communication of the digital operator is abnormal. Take out the operator after power-off and then mount it again for a trial.
- (3) The motor cannot rotate reverse.
Reverse rotation is disabled.
- (4) The motor rotates in the opposite direction.
The output line is wrongly connected. Please change any two lines of U.V.W over.
- (5) The deceleration of the motor is too slow.
- 1) The setting of Ramp-down Time is too long. Decrease Ramp-down Time.
 - 2) Add a braking resistor.
 - 3) Add a DC brake.
- (6) Over-heat of the motor
- 1) The load is too large. The actual torque has exceeded the rated torque of the motor. It is recommended to increase the capacity of the motor.
 - 2) The ambient temperature is too high. In a place with higher temperature the motor will be burn out. Please decrease the temperature around the motor.
 - 3) The phase to phase withstand voltage of the motor is insufficient. The switch actions of the inverter will make the winding coil of the motor produce shock wave. Typically the maximum shock voltage will reach 3 times that of input power of the inverter. Please select a motor with higher phase to phase withstand voltage against shock than the maximum shock voltage.
- (7) The starting of the inverter interferes with other control devices
- 1) Decrease the carrier frequency and reduce the number of actions of internal switches.
 - 2) Install a noise filter at the power input of the inverter.
 - 3) Install a noise filter at the output of the inverter.
 - 4) Make correct grounding for the inverter and the motor.
 - 5) Use metal conduit to tube the cable to shield it.

- 6) Make separate wiring for the main circuit wires and control wires.
- (8) When the fan starts the inverter detected an over-current stall.
- 1) At start the fan rotates idly. Please set it for DC braking at start.
 - 2) When DC braking at start has been set, increase the DC braking value.
- (9) The machine has the noise of vibration or roar
- 1) The vibration frequency of mechanical system resonates with the carrier. Adjust the carrier to avoid the point of resonance.
 - 2) The vibration frequency of mechanical system resonates with the output frequency of the inverter.
 - a. Set it for skip function to avoid the point of resonance.
 - b. Put rubber vibration isolator on the base plate of motor.

Common abnormalities and solutions

The analysis and measures for the common abnormalities refer to the following table:

Abnormity		Possible Causes and Solutions
Mot or Not Run	No display on keyboard	Examine whether the power supply is on, the input power has phase or is connected correctly
	The keyboard does not display, but the charge indicator lamp is ON	Examine the wires of the keyboard and the socket; Measure the voltage of controlled power supply, so as to confirm whether the switch power is running normally; If the switch power is not running properly, examine whether the socket of switch power inlet (P, N) is connected well, whether the vibration resistance is damaged or the stabilizing pipe is normal.
	No voltage of low voltage of PN terminal	Examine the charging return circuit.
	Motor buzz	The motor is under heavy load, please try to reduce the load.
	No abnormality is found	Check whether the inverter is in the state of trip or has not been reset after trip; whether it is in the state of restart after power break; whether the keyboard is reset; whether it accesses to the program running state or the multi-speed running state. For the running state or non-running state, use the method of restoring the factory setting to confirm whether the running command is given. Examine whether the running frequency is set as 0.
Motor can not accelerate or decelerate smoothly	Inappropriate setting of ramp time; Too low current amplitude; Over-voltage protection during deceleration; Inappropriate setting of carrier frequency, over-load or vibration appears	

Too high or too low motor rotation speed	Inappropriate V/F feature selection; Incorrect V/F feature level selection, to be reset; Substandard or non-standard rated voltage of motor; Too low voltage of power supply; Incorrect setting of frequency set signal gain; Incorrect setting of output frequency.

XI. Selection of Peripheral Devices and Disposition

1. Options

Description	Functions
NFB or Ground fault interrupter for wire connection	Protect the wiring of the inverter. Be sure to install a breaker at the power. Please select a ground fault circuit interrupter against high-order harmonics.
Electromagnetic contactor	In order to prevent the braking resistor from burning out, please add an electromagnetic contactor and connect a surge absorber to the coil when using it.
Surge absorber	Absorb the switching surge current from the electromagnetic contactor and control relays.
Isolating transformer	Its function of isolating the input and output of the inverter is effective to reduce the interference to other electric devices.
DC reactor	Improve the input power factor of the inverter.
AC reactor	Improve the input power factor of the inverter and prevent the shock of surge voltage.
Braking resistor, braking unit	Consume the regenerating energy of the motor and shorten the ramp-down time.

1) Leakage switch

There is earth static capacity inside of the inverter and the motor as well as the input and output leads. Due to higher carrier frequency of the inverter, the inverter has higher earth leakage current, especially for the inverters of large capacity series. When using a leakage switch, it may sometimes result in the error action of the protective circuit. So when using a leakage switch, attention should be paid to its selection and the proper reduction of carrier frequency and shortening the leads, etc.

2) AC reactors

An AC reactor can constrict the high-order harmonic of input current of the inverter to improve its input power factor and prevent the shock of surge. It is recommended to use an input AC reactor under the following circumstances:

- a: Three-phase power supply is in unbalance.
- b: Any equipment with thyristor or power factor compensation unit with switching control is connected to the same power supply.

3) DC reactors

It is necessary to install a DC reactor when the capacity of power supply is more than 1000 KVA or the mains power capacity is higher than the rated capacity of the inverter. A DC reactor is also needed for the case with higher demand on the improvement of power factor of power supply. This DC reactor can be used together with an AC reactor to achieve the obvious effect of decreasing high-order harmonic at input. If it is necessary to install a DC reactor, please contact the local distributor.

2. Disposition

1) DC Reactors Disposition

Inverter Model	Matched Power (W)	Rated Current(A)	Inductance (mH)
DCL-37	37	100	0.7
DCL-45	45	120	0.58
DCL-55	55	146	0.47
DCL-75	75	200	0.35
DCL-90	90	238	0.29
DCL-110	110	291	0.24
DCL-132	132	326	0.215
DCL-160	160	395	0.177
DCL-200	200	494	0.142
DCL-220	220	557	0.126
DCL-280	280	700	0.10
DCL-300	300	800	0.08
DCL-315	315	800	0.08
DCL-345	345	660	0.07
DCL-375	375	715	0.064
DCL-400	400	765	0.058
DCL-415	415	795	0.053

Connection: (1) Remove the jumpers of P and P1 terminals.

(2) Connect DC reactor to Terminals P and P1 as shown in the following diagram:

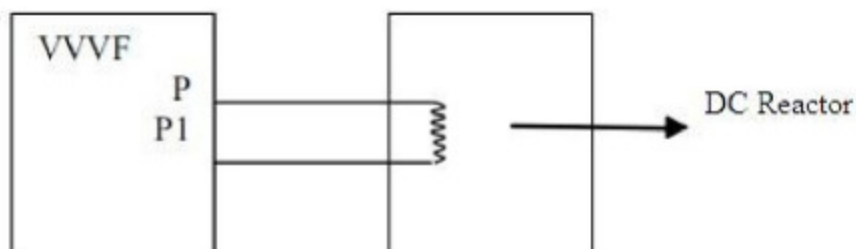

Note: RLP inverter of above 37KW has connectors. The inverter of below 37KW must not be connected with it.

The function of DC reactor is to restrict the AC component stacked with DC reactor to a specified value to suppress the mains harmonics and improve the power factor of the inverter.

2) AC Reactors Disposition

Inverter Model	Matched Power (W)	Rated Current(A)	Inductance (mH)
HKSG2-24	14	24	0.52
HKSG2-34	15	34	0.397
HKSG2-38	18.5	38	0.352
HKSG2-50	22	50	0.26
HKSG2-60	30	60	0.24

HKSG2-75	37	75	0.235
HKSG2-91	45	91	017
HKSG2-112	55	112	016
HKSG2-150	75	150	0112
HKSG2-180	90	180	010
HKSG2-220	110	220	0.09
HKSG2-265	132	265	0.08
HKSG2-300	160	300	0.07
HKSG2-360	200 (185)	360	0.06
HKSG2-400	220	400	0.05
HKSG2-560	280	560	0.03
HKSG2-640	315	640	0.0215
HKSG2-700	345	700	0.019
HKSG2-750	375	750	0.017
HKSG2-800	400	800	0.015
HKSG2-860	415	860	0.012

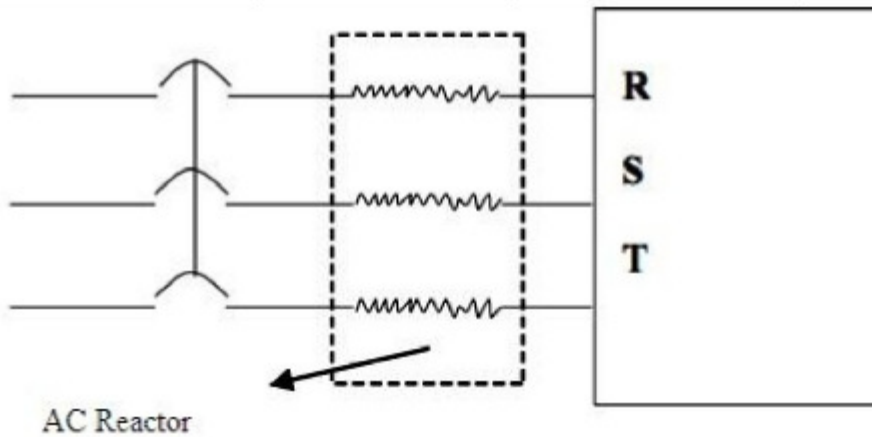

The incoming reactor is also named shift-changing reactor and it is used for the incoming wire of the mains with AC flowing inside. Its function is to suppress the harmonics of the inverter feedback to the mains.

Inverter Model	Braking resistor specification		Braking torque 10%ED	Special Motor KW
	W			
RLPA00D423B	80	200	125	0.4
RLPA0D7523B	100	200	125	0.75
RLPA01D523B	300	100	125	1.5
RLPA02D223B	300	70	125	2.2
RLPA0D7543B	80	750	125	0.75
RLPA01D543B	300	400	125	1.5
RLPA02D243B	300	250	125	2.2
RLPA03D743B	400	150	125	3.7
RLPA05D543B	500	100	125	5.5
RLPA07D543B	1000	75	125	7.5
RLPA001143B	1000	50	125	11

RLPA001543B	1500	40	125	15
RLPA18D543B	4800	32	125	18.5
RLPA002243B	4800	272	125	22
RLPA003043B	6000	20	125	30
RLPA003743B	9600	16	125	37
RLPA004543B	9600	13.6	125	45
RLPA005543B	12000	20/2	125	55
RLPA007543B	18000	13.6/2	125	75
RLPA009043B	18000	20/3	125	90
RLPA011043B	18000	20/3	125	110
RLPA013243B	24000	20/4	125	132
RLPA016043B	36000	13.6/4	125	160
RLPA018543B	45000	13.6/5	125	185
RLPA020043B	45000	13.6/5	125	200
RLPA022043B	48000	13.6/5	125	220
RLPA025043B	48000	13.6/5	125	250
RLPA028043B	57600	13.6/6	125	280
RLPA030043B	57600	13.6/6	125	300

For the braking resistor used for the machines of above 315 KW,

please contact the factory.

For the inverter of above 11KW to realize quick brake, a braking unit must be added.

Note: 1: Please select the resistor value and operating frequency given by our company.

- 2: If it causes any damage to the inverter and other devices due to the use of any braking resistor and braking model group not supplied by our company, we will take no responsibility.
- 3: Be sure to consider the safety and ignitability of the environment when installing a braking resistor. The distance to the inverter should be at least 100 mm.
- 4: If it is necessary to change the resistor value and power value, please contact the local distributor.
- 5: In need of a braking resistor a separate order must be placed. Please contact the local distributor for details.

XII. Appendices

Appendix 1: Simple Examples of Application

1. Disturbance Function (Generation of Triangle Wave)

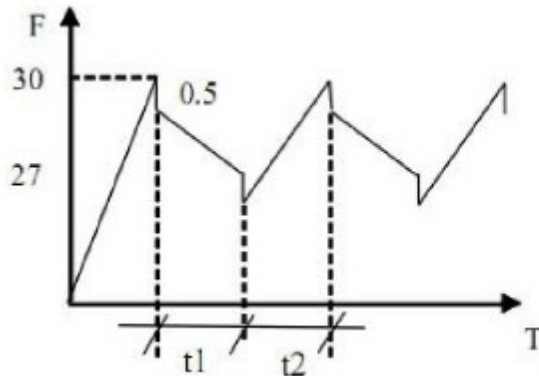

A curve as in left is generated.
Parameter setting:

Pd080=5 Pd003=30
Pd086=27 Pd092=0.5
Pd101=10 Pd102=10

2. Drawing Function

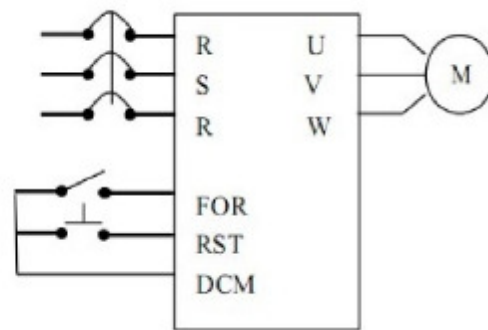
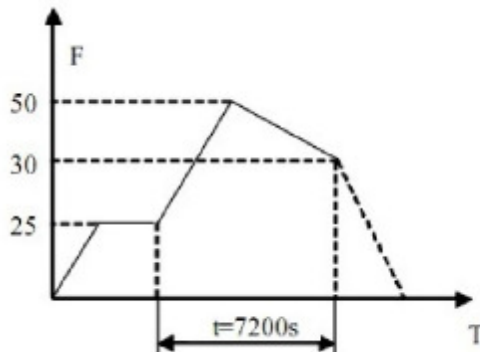

Parameter setting:

Pd081=4 Pd003=25 Pd086=50 Pd087=30
Pd101=720 Pd046=29 Pd001=1

Note: (1) When triggered by external multi-function terminals (as RST in the diagram), the drawing action starts to be implemented.

(2) In implementation of drawing action the running time $T = P101 * 10S$

3. FOR/REV Rotation of the Motor Controlled by One Potentiometer

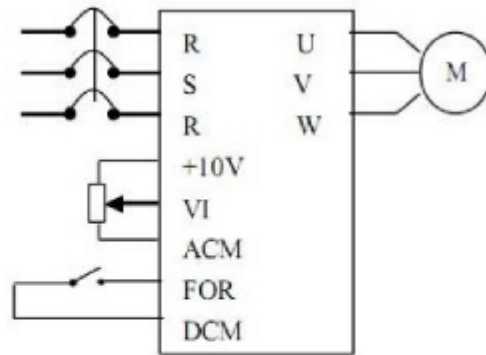
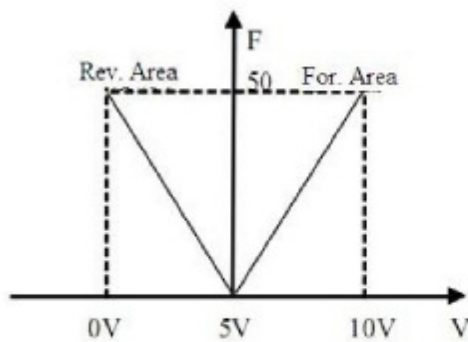

Para setting: Pd001=1 Pd002=1 Pd072=50 Pd073=50 Pd074=0
Pd075=1 Pd076=1

4. Internal Control 8 Speed Run

A curve as shown in the following diagram is established. Internal control 8-speed run will stop after running for one cycle.

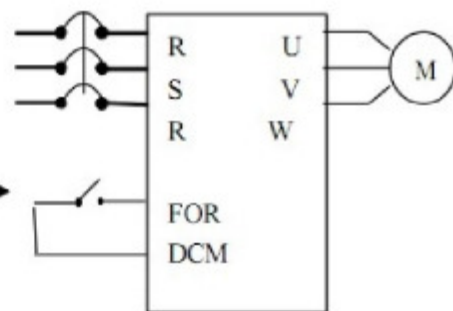
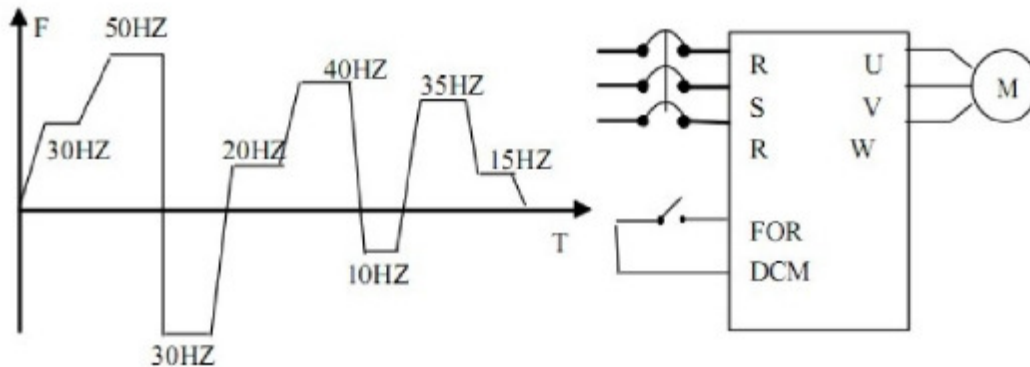

Para setting: Pd080=1 Pd003=30 Pd086=50 Pd087=30 Pd088=20
Pd089=40 Pd090=10 Pd091=35 Pd092=15 Pd082=36
Pd081=0 Pd014=5 Pd015=5 Pd001=1 Pd083=0
Pd044=1 Pd101-Pd108=15

Note: 1. The running time of each speed is set by Pd101-Pd108=15;

2. Auto cycling Pd081=1;

3. After the running command is given, it will run with the set curve for one cycle and stop.

5. Simple Water Supply with Constant Pressure

□ Use a pressure transmitter with measuring range of 0-10kg, feedback of 4-20mA, requiring water supply at the pressure of 5kg with alarming at the upper limit of 6kg and the lower limit of 4kg. The start from the panel stops.

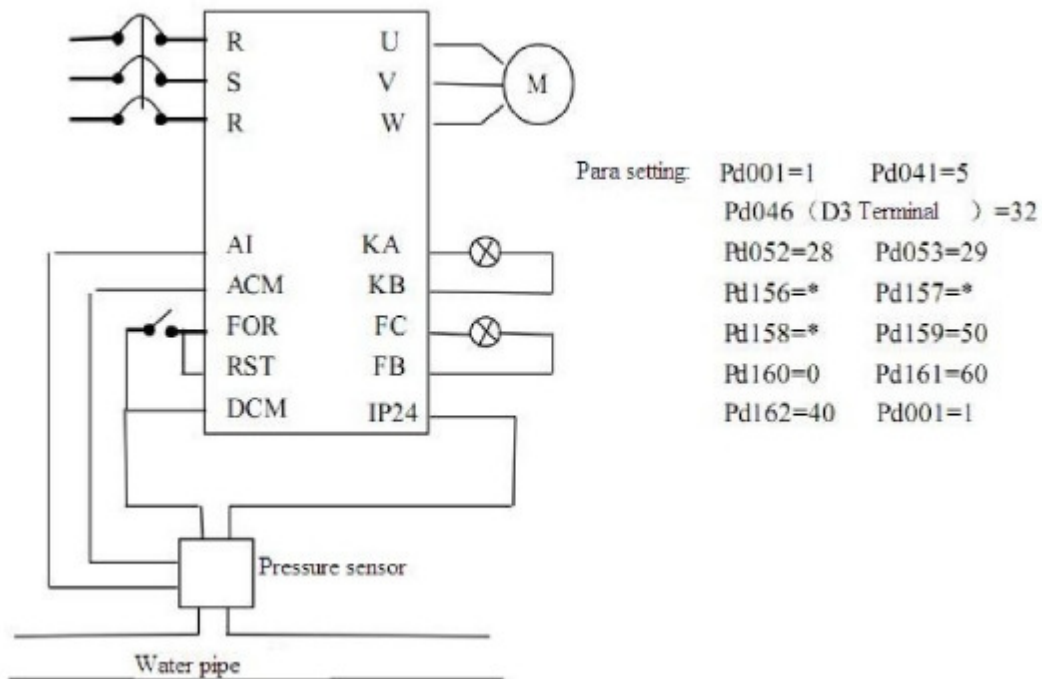

Note: Pd156, Pd157 and Pd158 should be set according to the actual conditions. For general water supply with constant pressure, Pd150=80~100, Pd151=2.5~3, Pd152=0.

□ For a resistance transmission pressure gauge of 0~10kg, it is required to control operation and stop by external terminals and give a target value through a potentiometer.

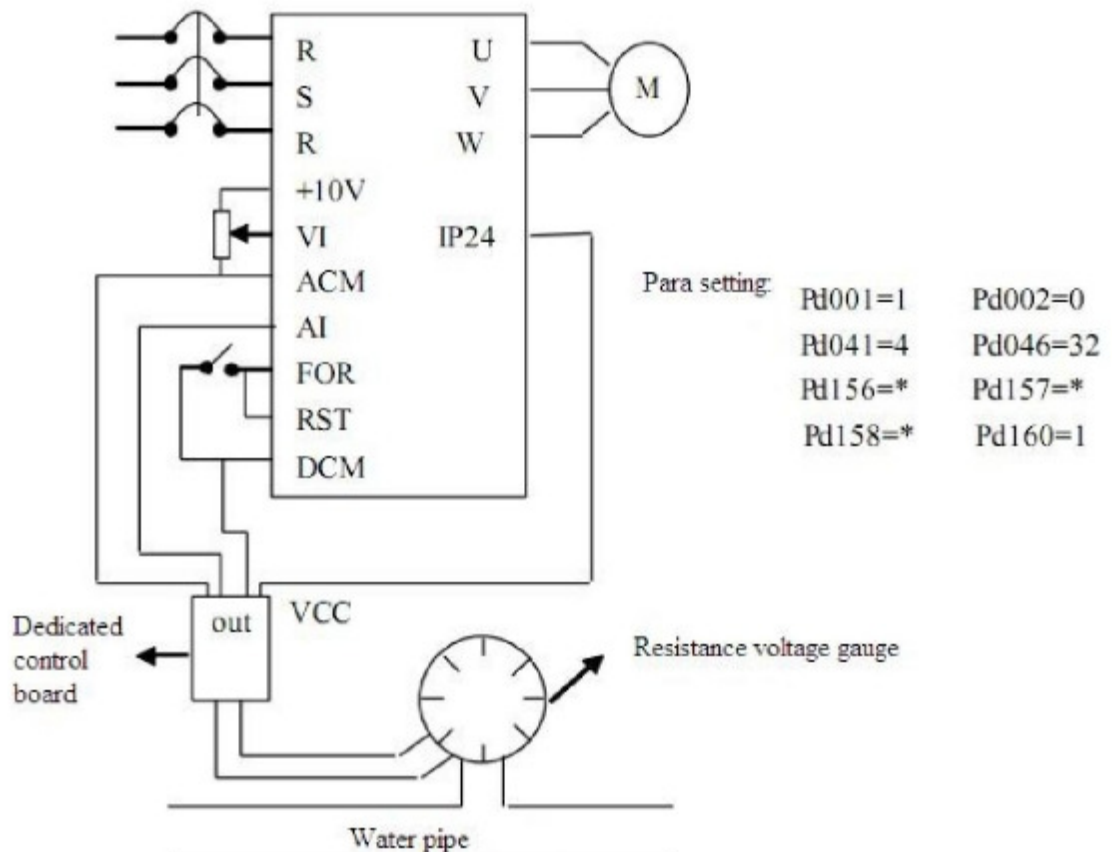

Attention:

- (1) The target value of RLP series inverter can be selected in two ways, one is to set it on the panel and another is the analog of 0~10V;
- (2) The feedback signal is 4-20mA. Others are invalid;
- (3) In this example the target value is given by the potentiometer (0~10V) ;
- (4) Pd156, Pd157 and Pd158 should be set according the actual condition. (Refer to the parameter description.)
- (5) The special panel for PID is designed according to general resistance transmission pressure gauge with input internal resistance converting to the standard signal in 0-400Q. When the resistance value of the resistance transmission pressure gauge used by the customer exceeds the specified range, please change the resistance transmission pressure gauge or connect a resistor in parallel for correction.
- (6) Output resistance values vary with different manufacturers of resistance transmission pressure gauge. After conversion, the levels of current signal are different. The user can set a target value consistent with its actual conditions by themselves.
- (7) The target value is given by the potentiometer. Pd002 must be set as 1, otherwise PID will not work.

6. Example common application of analog and multi-speed:

Requirement: Speed 1 is given frequency by analog. Use a switch to switch it and turn to external control multi-speed run.

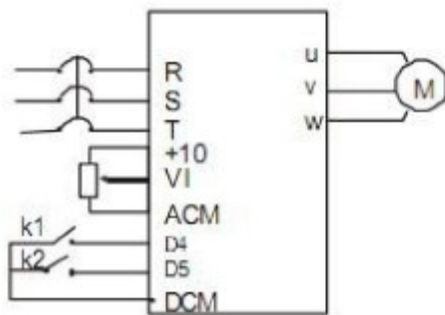

Para setting: Pd002=1 Pd081=2
 Pd047=20 Pd048=21
 Pd086=15 Pd087=30
 Pd088=25

Action Description: (1)

K1 State	K2 State	Operating Frequency
OFF	OFF	Given by a potentiometer
ON	OFF	Speed 2 (15Hz)
OFF	ON	Speed 3 (30Hz)
ON	ON	Speed 4 (25Hz)

(2) The switching of forward and reverse rotation can be implemented through either multi-function terminals or the FOR/REV key on the panel. (In this example, the switching is made through the panel)

7. Example application of Auto PLC Suspend

Requirement: Auto PLC can be suspended during the internal control multi-speed run.

After handling the related problems, it can resume.

(1) Connection

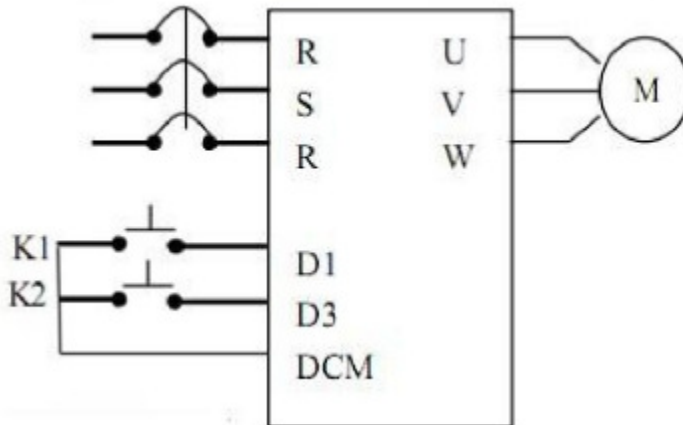

- (2). Parameters:
- Pd001=1 D1 terminal control operation
 - Pd049=31 SPL terminal is set for Auto PLC reset suspend function.
 - Pd117=1 Auto PLC Memory
 - Pd081=1 Cycling run
 - Pd080=1 Internal control multi-speed
 - Pd086=15 Pd088=20 Pd086=25 Pd003=10
 - Pd101=10 Pd102=10 Pd103=10 Pd104=10

(3) Operating curve:

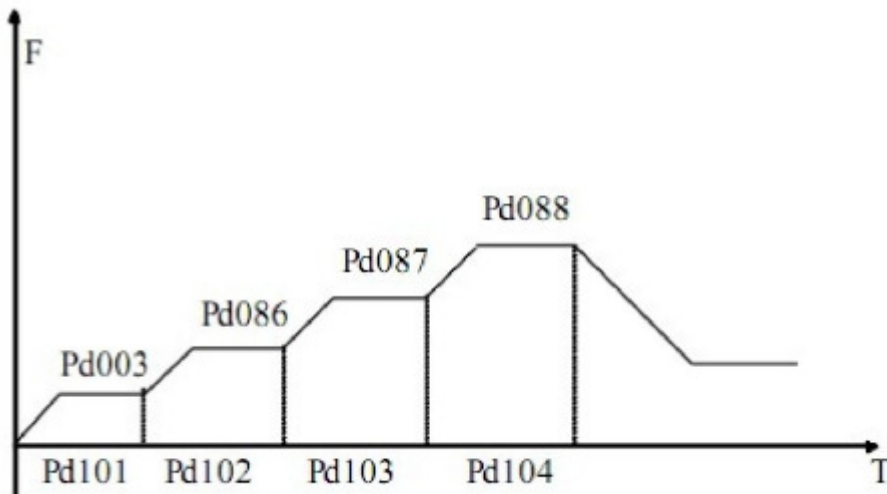

(4) Operation description

- (K1) D1 is closed and the inverter will run according to the program set by internal control multi-speeds.
- When it is required to stop due to fault and process or other reasons, K1 will be opened. And the inverter will stop output and suspend counting time. After the fault is removed, K1 will be closed and the inverter will continue to run according to original program.
- When it is required to run again from the beginning due to fault and process stop, K1 should be opened. Press K2 to reset. By closing K1, it will restart to run.

8. Application example of plastic injection machine

Control principle diagram

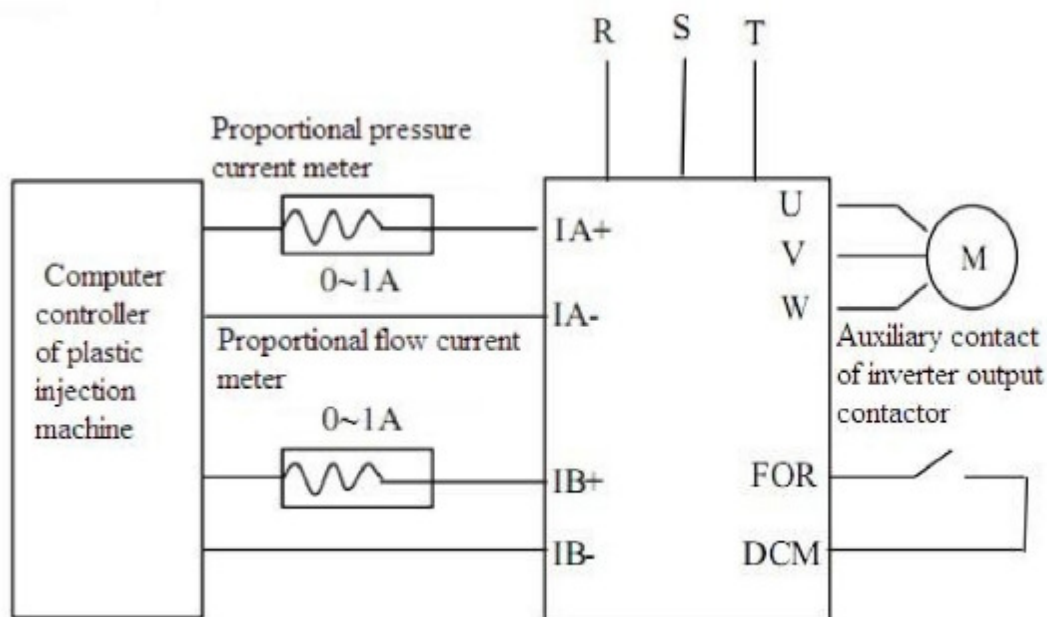

Para
setting: PD001=1 PD003=50 PD014=2 * PD015=2 * PD044=02
PD070=9 PD072= 50* PD073=20* PD075=1

Note: Places marked with "*" are to be decided upon the concrete conditions.

When the inverter is under operation, please do not shift the switch. When it has to be shifted, make sure the inverter stops the output.

