

Vitkovets CNC

 <http://cnc.prom.ua/>

 +380 (096)-665-71-06
+380 (098)-821-25-90

 cncprom@ukr.net

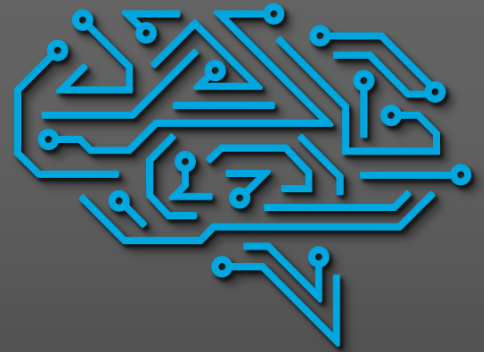





C N C P R O M

**Technical manual: 110ST-M06030, 130ST-M07725,
130ST-M15015, 130ST-M10025**



Safety Caution

In order to ensure the safe use of this product, must observe the following safety signs, in order to avoid damaging to the people and the equipment

 警告 warning	Said wrong operation will trigger dangerous, leading to mild or moderate personal injury, damage to equipment, and even fire
 危险 dangerous	Said wrong operation will trigger dangerous cause injury or death
	Said Prohibit operation
	Said must operate

After the product arriving, when validation, installation, wiring, operation maintenance, inspection of the product, the following is one of the important matters must abide by:

- Matters needing attention during installation :

 警告 Warning
<p>It is forbidden to install will happen in the damp and corrosion environment, a flammable gas environment, and near combustible dust and metal powder more environment, or you may get an electric shock and fire.</p>

Matters needing attention during installation wiring

 警告 Warning
<ul style="list-style-type: none"> ▲ The earthing terminal of the servo drive must be grounded, otherwise, will get an electric shock and fire could occur ▲ It is forbidden to put the output terminal of the servo drive, U, V, W, connected to a three phase power supply, otherwise, could be injured and fire ▲ It is strictly prohibited to connect the 220v driver to 380 v, 220 v power supply, or you may get an

electric shock and fire

- ▲ Be sure to tighten power terminal, motor output terminal, otherwise may cause a fire

The matters needing attention when running:



危险

Dangerous

- ▲ In the operation , it is forbidden to touch any rotating parts, or you might get hurt
- ▲ In the operation, it is forbidden to touch electric motor and drive, otherwise you may burn



警告

Warning

- ▲
Before operating, must choose the right motor type, otherwise people will be hurt and the equipment will be damaged.
- ▲
Before operating, you must set right parameters and applications that meet the needs of users, or may be hurt, damage to equipment
- ▲
Before operating, confirm whether the mechanical may at any time the emergency stop, otherwise, you might get hurt.



Maintain the points for attention during the inspection :



- ▲
It is forbidden to touch the inside of the servo drive, or you may get an electric shock
- ▲
When turn off the power,in the five minutes, do not touch terminals, otherwise, the residual voltage may cause electric shock
- ▲
It is forbidden to tear open outfit servo motor, or you may get an electric shock

CATALOGUE

Chapter 1	Product inspection and installation.....	1
1.1	PRODUCT INSPECTION	1
1.2	PRODUCT BRAND	2
1.3	THE FRONT PANEL OF PRODUCT	2
1.4	DRIVE TECHNOLOGY SPECIFICATIONS	4
1.5	SERVO MOTOR INSTALLATION	5
1.6	THE MOTOR DIRECTION OF ROTATION	6
1.7	THE KRS SERIES DRIVE AND MOTOR MODEL ADAPTATION	7

CHAPTER 2 WIRING..... 8

2.1	THE SYSTEM COMPOSITION AND WIRING	8
2.2	CN1 COMMUNICATION INTERFACE	11
2.3	CN2 CONTROL INTERFACE.....	13
2.4	CN3 ENCODER INTERFACE	18
2.3	THE STANDARD WIRING.....	19

CHAPTER 3 PANEL OPERATION ... 21

3.1	PANELS.....	21
3.2	MODE SWITCH	21
3.3	MONITORING MODE OPERATION	22
3.4	AUXILIARY MODE OPERATION	22
3.5	USER PARAMETER MODE OPERATION	30

CHAPTER 4 FUNCTION PARAMETERS 31

4.1	PARAMETER SETTINGS PANEL	31
4.2	PARAMETER LIST.....	32
4.3	PARAMETERS	44
4.4	PORT FUNCTIONS.....	87

CHAPTER 5 MONITORING PARAMETERS AND

OPERATION 92

5.1	MONITOR PANEL OPERATION	92
5.2	MONITOR THE PARAMETER LIST	93

CHAPTER 6 ALARM AND PROCESSING 94

6.1	ALARM CLEARANCE OPERATION	94
6.2	ALARM CONTENT AND COUNTERMEASURE.....	94

MODBUS COMMUNICATION CHAPTER 7

FUNCTION 100

7.1 M MODBUS COMMUNICATION INTRODUCTION..... 100

7.2 COMMUNICATION PROTOCOL STRUCTURE 101

7.3 COMMONLY USED COMMAND CODE..... 103

7.4 THE SERVO PARAMETERS, THE STATE INFORMATION COMMUNICATION ADDRESS
..... 115

THE APPENDIX 116

APPENDIX A GAIN SWITCH 116

APPENDIX B CONTROL MODE SWITCH 116

APPENDIX C SERVO DRIVER WORK SEQUENCE 120

APPENDIX D ELECTROMAGNETIC BRAKE 121

APPENDIX E REGENERATIVE BRAKING RESISTOR 122

APPENDIX F ORIGIN POINT 123

APPENDIX G INTERNAL POSITION CONTROL 131

Chapter One products inspection and installation



1.1 Product inspection

This product has made the complete function test before the leaving the factory, to prevent the product in the course of transportation for negligence resulted in the product (s) is not functioning properly. Once opened, please check the detailed the following matters:

- check the servo drive and servo motor type with the same whether order model
- Check the appearance of the servo drive and servo motor whether there is any damage and scratches phenomenon.If there is any damage during the shipment, please don't wire power transmission.
- Check the servo drive and servo motor if there is any loose parts and other phenomenon. If there is a loose screw, screw not lock or fall off
- Check the servo motor rotor shaft can be smooth rotation. The motor with brake cannot be directly rotation

If there is any fault or unmoral phenomenon, please contact with dealers immediately

1.2 ID label

AC SERVO DRIVER		 Danger Please install, connection, using as manual  Please don't install or un-install the driver when it is connected to the power and cut off the power within 5 min.
Model	ASDD-30A	
Voltage	AC220V/50-60HZ	
Output Current	30A	

1.3 The front panel

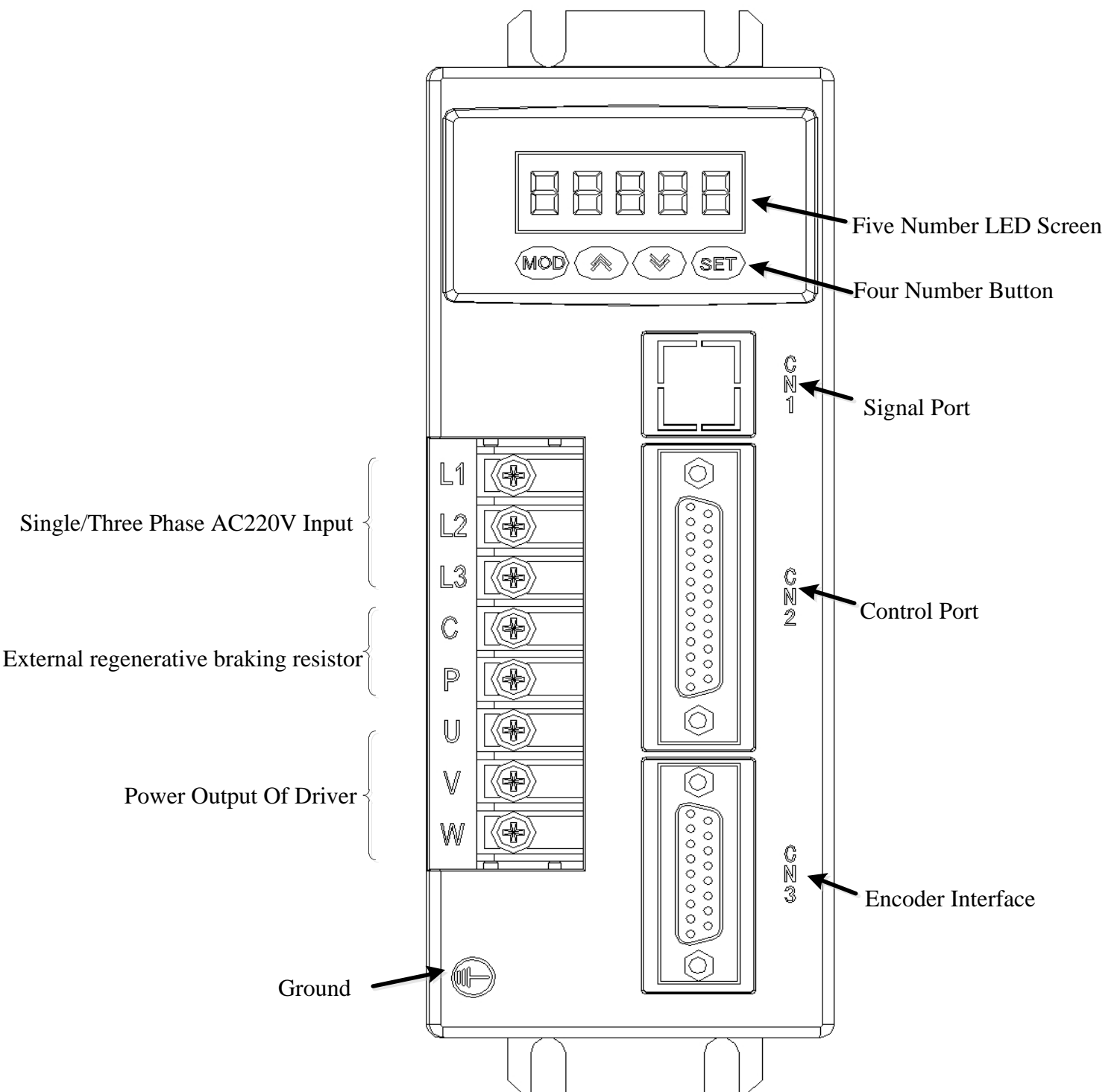

1.4 The function of AC servo motor driver

The input power		Single phase or three phase AC220V -15~+10% 50 / 60Hz
environment	temperature	Using: 0~55°C Storage: -20°C~80°C
	humidity	Below 90% RH No dewing
	vibration	Below 0.5G (4.9m/S), 10-60 no continue running
Control mode		IGBT PWM sine wave control
Control mode		<ul style="list-style-type: none"> ① Torque mode (internal or external) ② speed mode (internal or external) ③ Position mode (internal or external) ④ Position/velocity model ⑤ Position/torque model ⑥ Speed/torque model
Control input		<p>servo enables alarm reset Forward driving is prohibited Reverse driving is prohibited、</p> <p>External forward torque is limited, external reverse torque is limited Emergency stop, Zero speed clamp、</p> <p>Internal speed command option 1、 Internal speed command option 2 Internal speed command option 3 The internal torque command option 1 The internal torque command option 2 Control mode switch Gain switch Electronic gear molecular option 1 Electronic gear molecular option 2 Instructions for Position deviation to clear Pulse input is prohibited Proportional control The origin return to trigger、</p>

	<p>The origin return reference point</p> <p>Internal location option 1</p> <p>Internal location option 2、</p> <p>Trigger internal position command</p> <p>Suspend internal position command</p>
Control the output	<p>Alarm detection , Servo ready , Emergency stop checked out、</p> <p>Positioning to complete , Speed to reach</p> <p>Reach the predetermined torque</p> <p>Zero speed detection</p> <p>Servo motor current , Electromagnetic brake</p> <p>The origin return to complete 、 Located close to 、</p> <p>torque limit、 speed limit、 Tracking arrive torque command</p>
The encoder feedback	2500p/r, 15 line increment model, differential output
Communication mode	RS-232 OR RS-485
Display and operation	① five LED display ② Four buttons
Braking way	Through the internal/external braking resistance braking energy
Cooling way	Air cooled (heat transfer film, the strong cold wind fan)
Power range	≤7.5KW

1.5 Servo motor installation

1.4.1 Installation environment conditions

- Working environment: 0 ~ and °C; working environment: less than 80% (no condensation)
- Storage environment temperature: - °C; Storage environment humidity: 80% of the (no condensation)
- Vibration: Below 0.5 G
- Well ventilated, less moisture and dust place

- No corrosive, flash gas, oil and gas, cutting fluid, iron powder and so on environment

- No moisture and direct sunlight place

1.4.2 Installation method

- Level installation: to avoid liquids such as water, oil from motor wire end into the motor internal, please will cable outlet in below

- Vertical installation: if the motor shaft and the installation with reduction unit, must pay attention to and prevent reducer in mark through the motor shaft into the motor internal

- The motor shaft out quantity must be thoroughly, if insufficient out to motor sports generates vibration

- Installation and remove the motor, please do not use hammer knock motor, otherwise easy to cause damage to the motor shaft and encoder

1.6 The motor direction of rotation

Looking from the motor load on the motor shaft and counterclockwise (CCW) for the forward, clockwise (the CW) as the reverse

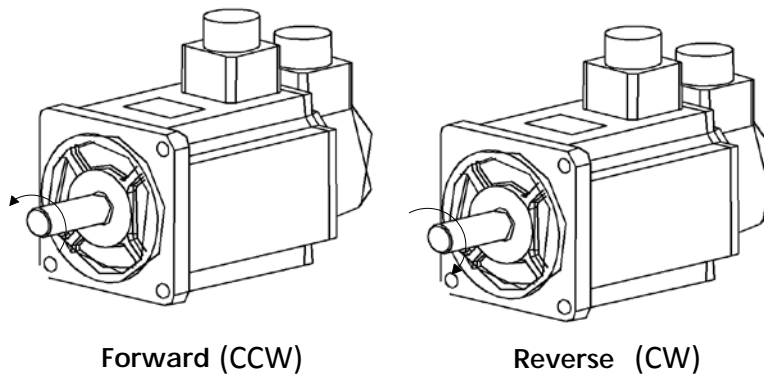

1.7 The KRS series drive and motor model adaptation

Motor model	Pn001	Rated speed (r/min)	Rated torque (N. M)	Rated power (W)	KRS	KRS	KRS	KRS	KRS
					15A	20A	30A	50A	75A
60st_m00630	0	3000	0.6	200	✓	✓	✓		
60st_m01330	1	3000	1.3	400	✓	✓	✓		
60st_m01930	2	3000	1.9	600	✓	✓	✓		
80st_m01330	3	3000	1.3	400	✓	✓	✓		
80st_m02430	4	3000	2.4	750	✓	✓	✓		
80st_m03520	5	2000	3.5	730	✓	✓	✓		
80st_m04025	6	2500	4	1000	✓	✓	✓		
90st_m02430	7	3000	2.4	750	✓	✓	✓		
90st_m03520	8	2000	3.5	730	✓	✓	✓		
90st_m04025	9	2500	4	1000	✓	✓	✓		
110st_m02030	10	3000	2	600	✓	✓	✓		
110st_m04020	11	2000	4	800	✓	✓	✓		
110st_m04030	12	3000	4	1200		✓	✓		
110st_m05030	13	3000	5	1500			✓		
110st_m06020	14	2000	6	1200	✓	✓	✓		
110st_m06030	15	3000	6	1800			✓		
130st_m04025	16	2500	4	1000	✓	✓	✓		
130st_m06015	17	1500	6	1000	✓	✓	✓		
130st_m05025	18	2500	5	1300		✓	✓		
130st_m06025	19	2500	6	1500			✓		
130st_m07725	20	2500	7.7	2000			✓		
130st_m10010	21	1000	10	1000	✓	✓	✓		
130st_m10015	22	1500	10	1500		✓	✓		
130st_m10025	23	2500	10	2600			✓	✓	✓
130st_m15015	24	1500	15	2300			✓		
130st_m15025	25	2500	15	3800				✓	✓
150st_m15025	26	2500	15	3800				✓	✓
150st_m15020	27	2000	15	3000				✓	✓
150st_m18020	28	2000	18	3600				✓	✓

150st_m23020	29	2000	23	4700				√	√
150st_m27020	30	2000	27	5500					√
180st_m17215	31	1500	17.2	2700				√	√
180st_m19015	32	1500	19	3000				√	√
180st_m21520	33	2000	21.5	4500				√	√
180st_m27010	34	1000	27	2900				√	√
220st_m67010	35	1000	67	1000					√

第二章 接线 Chapter 2 wiring

2.1 系统组成与接线 The system composition and wiring

2.1.1 伺服驱动器接线图 Servo driver wiring diagram

In general, It need a transfer to offer the 3phase 220v power, like the right Photo

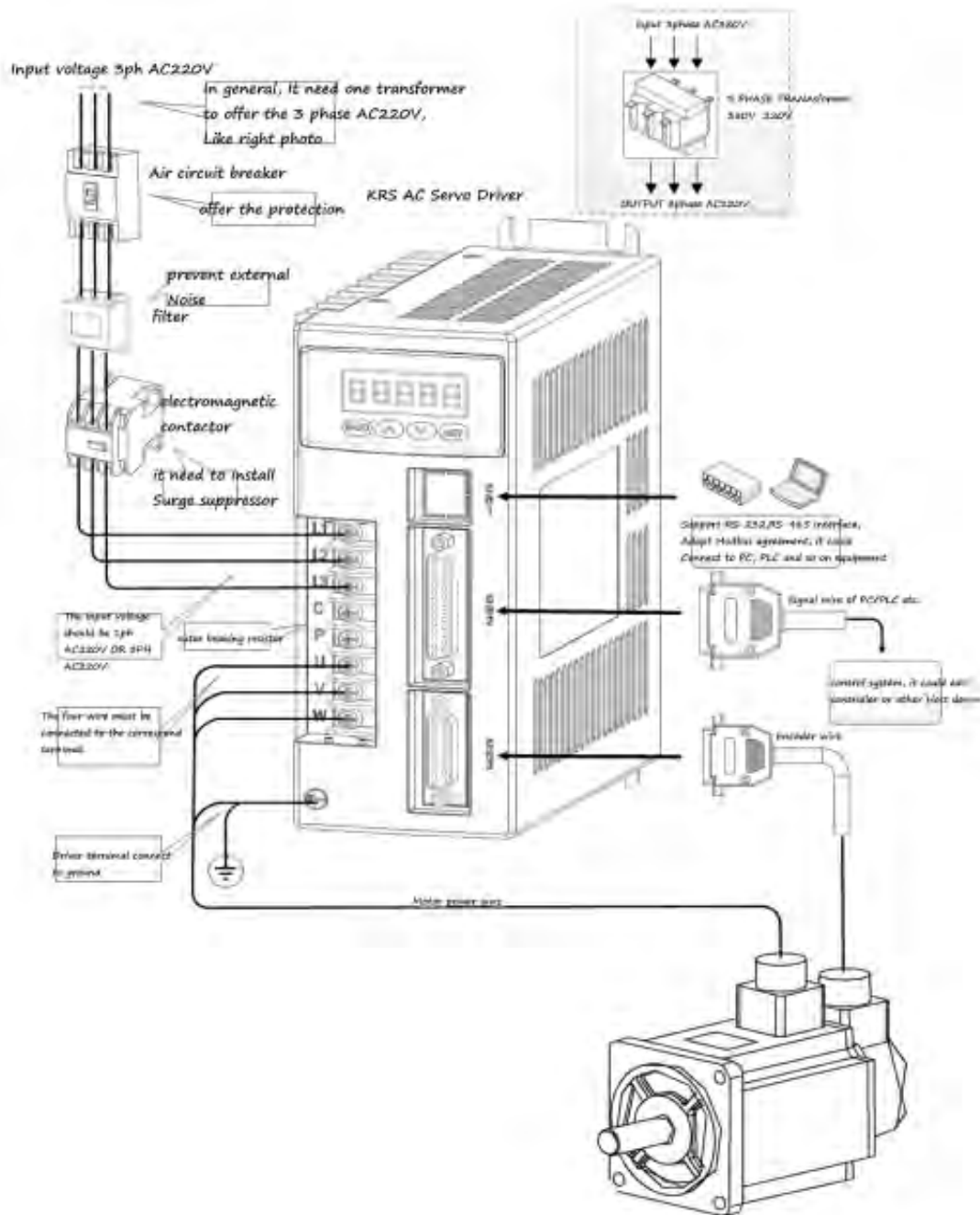

2.1.2 Wiring instructions

Wiring matters needing attention:

- The wire material should be in accordance with the wire specification.

- Cable length, instruction cable within 3 m, encoder cable within 20 m
- Check the L1, L2, L3 power wiring is correct or not, please do not connect to the 380 v power supply.
- U, V, W terminal phase sequence, must be corresponded to the terminal correspondence of the motor, otherwise, the motor may not transfer or coaster, the motor may not transfer or coaster. Can't use exchange three-phase terminal method to make motor reversal, this is totally different with asynchronous motor
- must be reliable grounding, and single point grounding
- into the output signal of the relay, the absorption of the direction of the diode to connected correctly, otherwise it will cause failure cannot output signal
- in order to prevent noise caused by the wrong action, please add in power transformer and noise filter device in the same wiring tube
- please install the fuse type circuit breaker that drive failure can promptly cut off the external power supply

2.1.3 Wire specifications

terminals	label	wire specifications
Power cord	U、V、	0.75~2.5mm ²
Motor terminals		0.75~2.5mm ²
Earthing terminal terminal		0.75~2.5mm ²
control symbol	C N 2	≥0.12 mm ² (AWG26), Including shielded
Encoder signal	C N 3	≥0.12 mm ² (AWG26), Including shielded

Encoder cable must use twisted-pair cable. If the encoder cable is

too long (> twenty m), can lead to encoder power supply shortage, its power source and ground can use multiple wire connection or use thick wire

2.1.4 High power Terminal instruction

name	Terminal symbol	Detailed description
Main circuit power	L1、L2、L3	Connect the external ac power three-phase 220VAC -15%~+10% 50/60Hz
Motor terminals	U	The output to motor U phase power
	V	The output to motor V phase power
	W	The output to motor W phase power
Earthing terminal		Motor shell earthing terminal
		Drive earthing terminal

2.2 CN1 Communication interface

2.2.1 CN1 Port Numbers

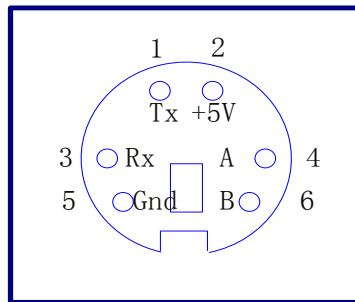

2.2.2 CN1 port

pin	number
+5V	2
GND	5
RS-232 Tx Send pin Tx	1
RS-232 Rx Receiving pin RX	3
RS-485 A	4

2.2.3 CN1 port type

1. RS-232 interface

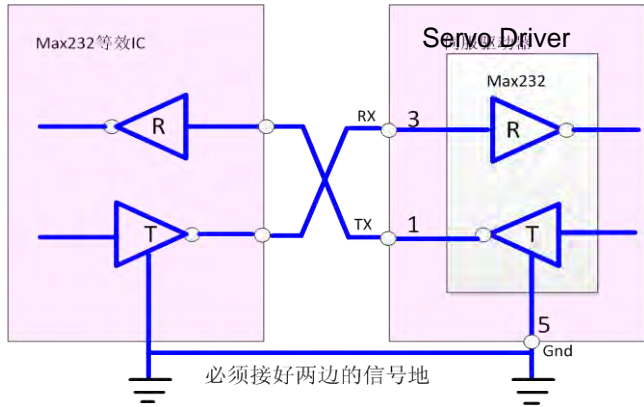

it must connect the two side signal ground

2. RS-485 interface

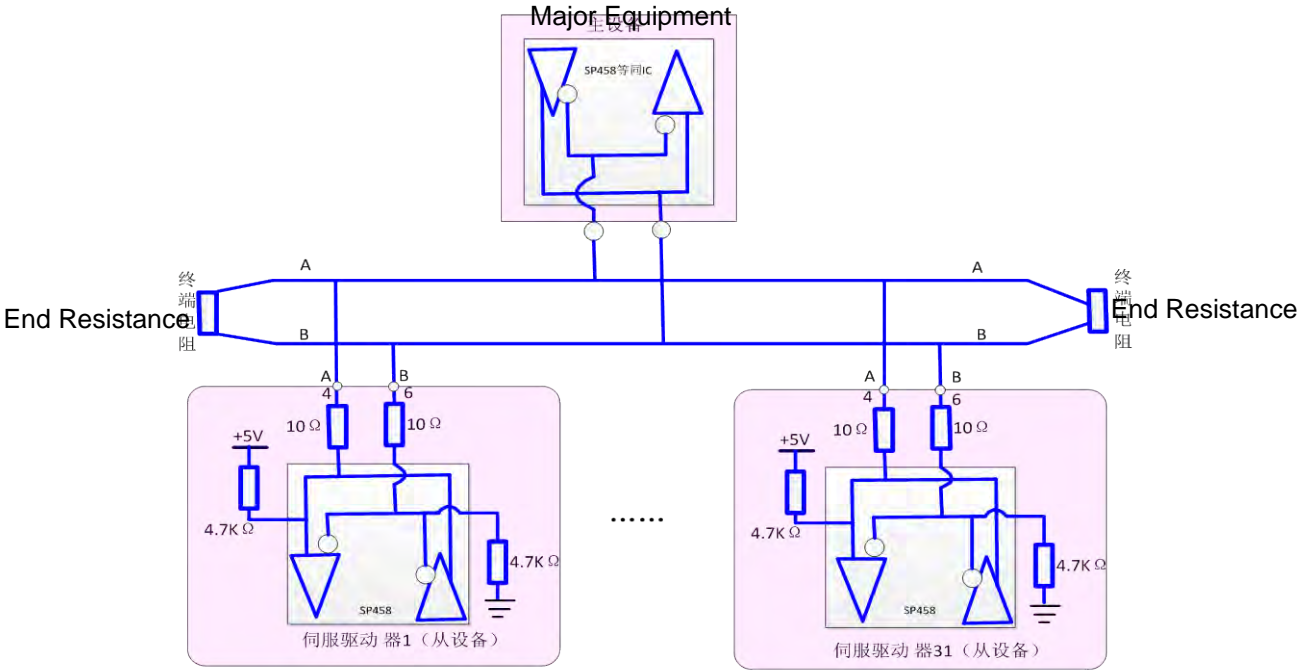

- Adopt RS485 communication, at the same time the most connected and table servo drive, 485 network terminals separately by one euro 120 resistance terminal resistances. If want to connect more equipment, must use Repeaters to expand the connection Numbers

2.3 CN2 Control interface

CN2 control signal terminal to provide and the upper controller connection need signal, use DB25 socket, signs include:

- Four programmable input
- Four programmable output
- Analog quantity order input
- Pulse command input
- Encoder signal input

2.3.1 CN2 port numbers

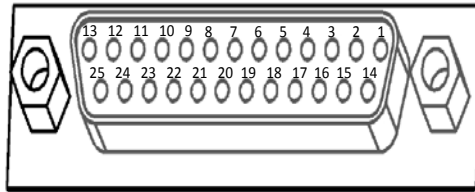

2.3.2 CN2 port instructions

pin	interface number	name	function
DC12~24V	9	The control signal of power supply and ground	Input/output control signal input power and ground
COM	10		
SigIn1	6	Input command signal	Input command signal. The factory all input signal port specified functions: SigIn1: Servo Enable SRV-ON SigIn2: alarm reset SigIn3: Zero position
SigIn2	7		
SigIn3	21		
SigIn4	8		

			deviation SigIn4: Zero speed clamp
SigOUT1 SigOUT2 SigOUT3 SigOUT4	11 23 12 24	output command signal	output command signal. The factory all output signal port specified functions: SigOUT1 Servo ready SigOUT2: Alarm detection SigOUT3: Positioning complete SigOUT4: Zero speed
PV PP+ PP- PD+ PD-	2 3 14 4 5	Instruction pulse input port	PV:open collector input power Instruction pulse can be three different ways to input 1 Instruction direction and pulse input 2 Clockwise or counterclockwise pulse input 3 Phase difference 90 degrees of orthogonal input
PA+ PA- PB+ PB- PZ+ PZ- OZ GND	20 19 18 17 15 16 22 1	Encoder signal output	Encoder signal (ABZ) output port. Through the parameter setting, AB signal separable frequency output and logic take back output.
Vref AGND	25 13	Analog input	Analog voltage input port. The speed or torque control, used for receiving the speed or torque command. Voltage input range-10V~+10V.

2.2.3 CN2 Port type

1. Digital input interface

DC12V~24V。Digital input interface circuit by switch, relay, open collector triode, photoelectric coupler of control. Relay required to choose low current relay, in order to avoid the phenomenon of poor contact. External voltage range DC12V ~ 24 V.

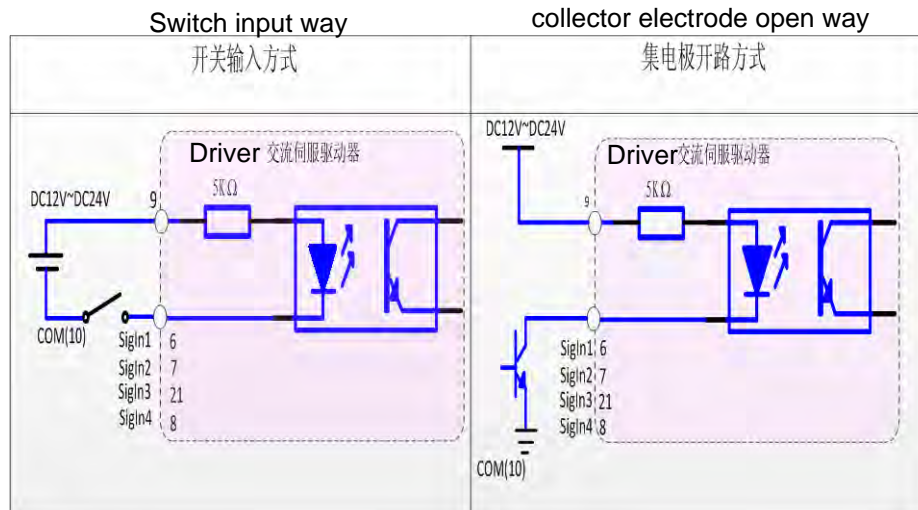

2. Digital output interface

Output circuit adopts darlington photoelectric coupler, but with relay, photoelectric coupler

Note:

- External power supply by users, but must pay attention to, if the power polarity meet back, may cause damage to the servo driver.
- When the output open collector form, the maximum current is 70 mA, the external power peak voltage is 25 V. If more than limit requirements or output directly with power connection, may cause damage to the servo driver.

- If the load is relay and inductive load, the load must be both ends against parallel fly-wheel diode. If fly-wheel diode picks back, may cause damage to the servo driver.

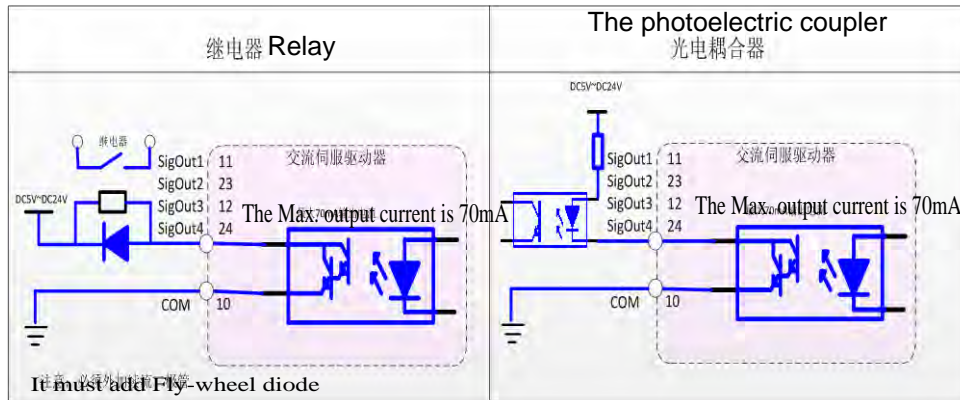

3. Position pulse command interface

A differential drive and single end drive have two connections , recommend differential drive connection. Connection appropriate USES twisted-pair cable

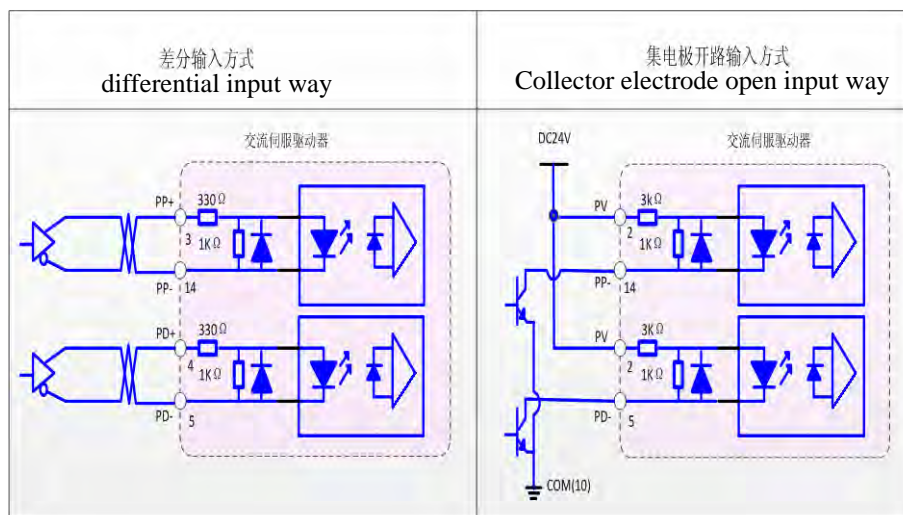

- In the differential input mode, it is recommended AM26LS31 similar line drive; In order to make the transfer of pulse data has good anti interference ability, it is suggested that the differential drive way; Maximum input pulse frequency 500 KHZ (KPPS).

- In the open collector input mode, the maximum input pulse frequency 200 KHZ (KPPS)

4. Encoder signal wire drive output

The encoder signal frequency division through line drive (26LS31) output to the upper controller

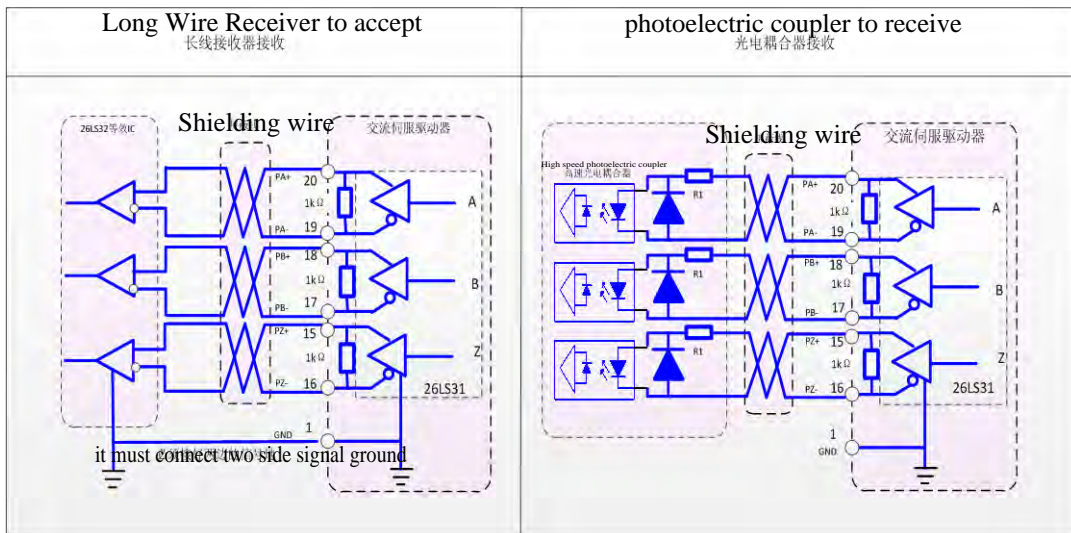

- In the long term receiver receive, the drive encoder signal (GND) must and upper controller signal ground connection
- In the photoelectric coupler receiving, upper controller using high-speed photoelectric coupler (such as 6 n137), current limiting resistor R1 value about 220 Ω.

5. Encoder Z signal open collector output

Servo drives to open collector mode on the output signal of the encoder Z. Because Z letter feel the pulse

width is narrower, PC please use high-speed photoelectric coupler receiving

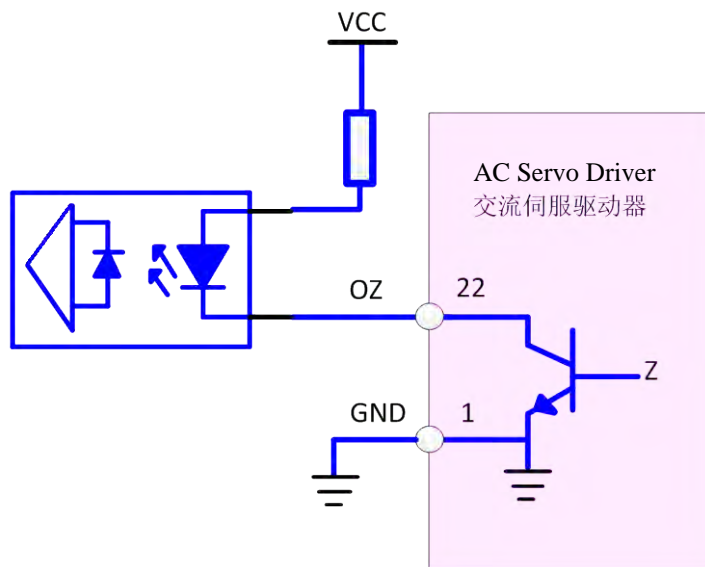

- VCC peak voltage 30 V, output current maximum 50mA

2.4 CN3 Encoder interface

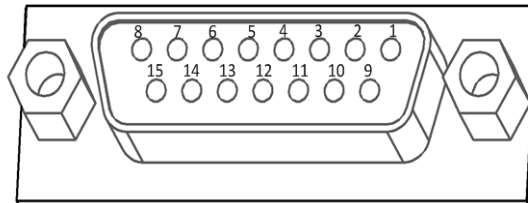

Connect the servo motor encoder signal to CN3 of the servo driver.

pin	CN3 number
+5v	8
GND	15
A+	3
A-	11
B+	10
B-	2
Z+	1

Z-	9
U+	6
U-	7
V+	5
V-	13
W+	12
W-	4
PE	14

2.3 Standard connection

2.3.1 Position control wiring diagram

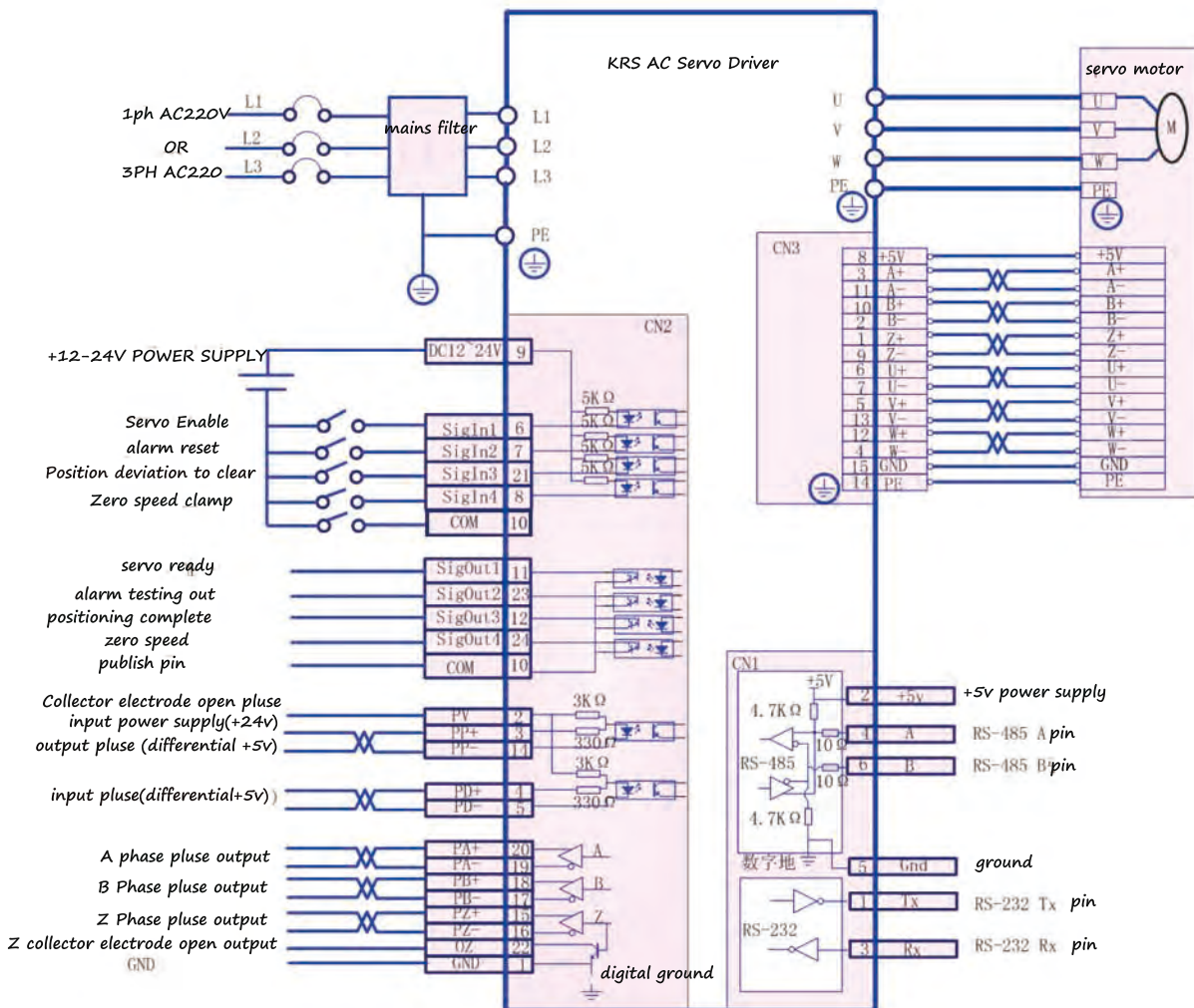

2.3.2 Speed, torque control wiring diagram

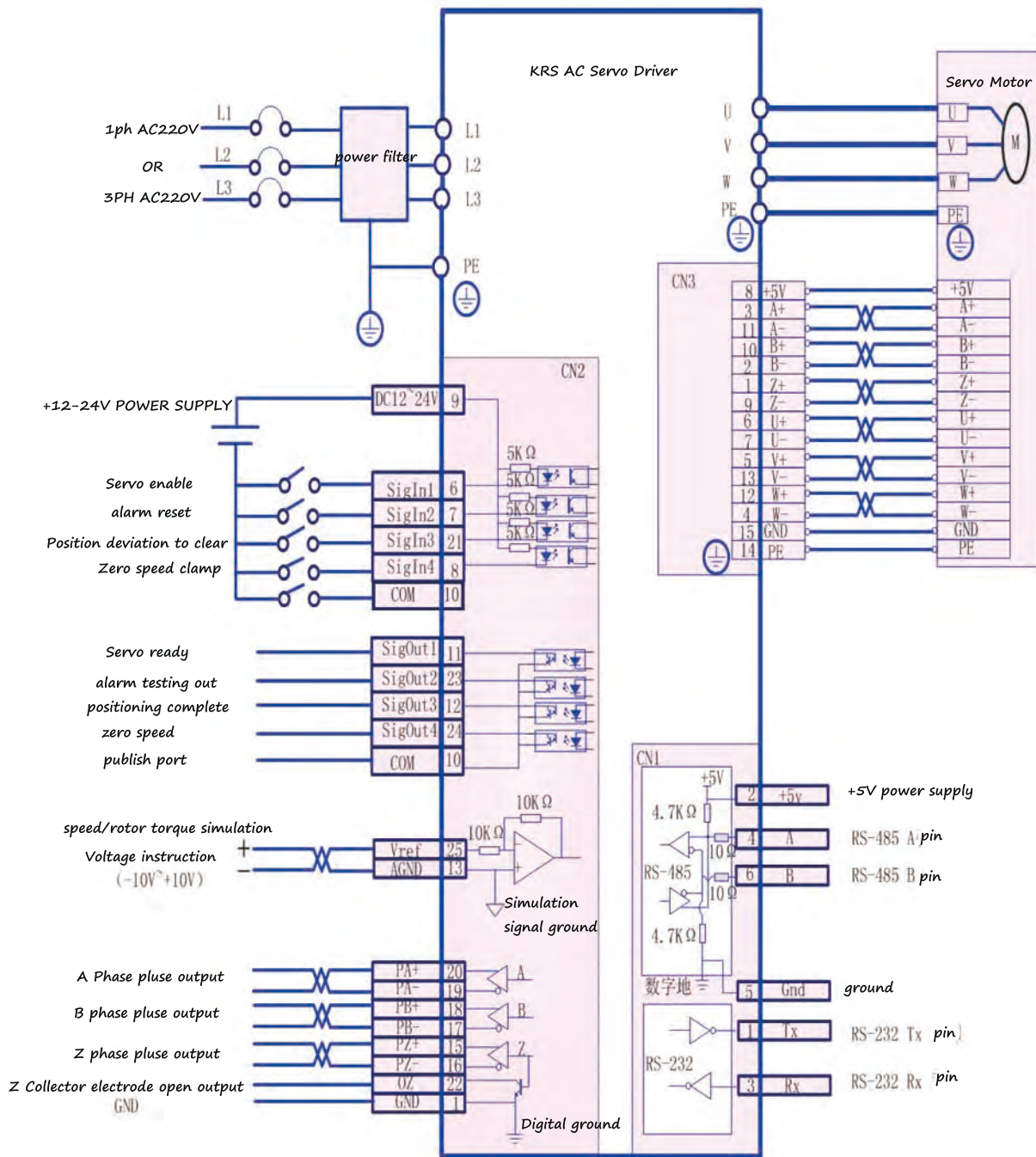

Chapter 3 Panel operation

3.1 panel

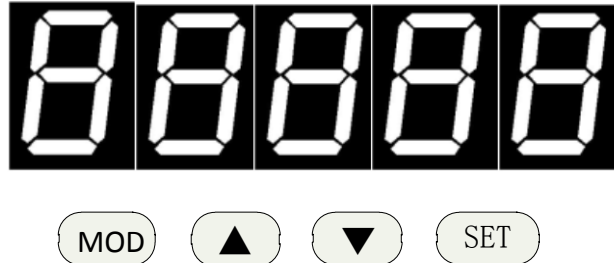

panel instruction:

key	key name	function
MODE	Mode option key	1 mode switch 2 Return to the superior directory
▲	Digital increase key	increase number,long press has the effect of repeat
▼	Digital reduce key	reduce number,long press has the effect of repeat
SET	Shift to determine Key	1 Digital shift 2 Determine the set (long by 1 second) 3 End set parameters (long by 1 second)

Note: if the five decimal points of the display are flashing, there are some alarm. Must clear the alarm, the drive can work normally.

3.2 mode switch

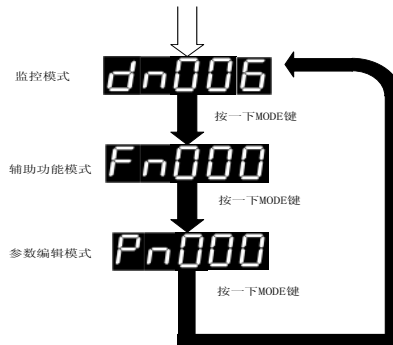

Note: when the screen shows Fnxxx, Dnxxx, Pnxxx, mode key at this time as the mode switching function, can be to switched to other mode directly, otherwise the mode key is as the function of returning to the upper directory.

3.3 Monitoring mode operation

Example: see dn015 monitoring parameters, sigOut1 port at this time as the low level, sigOut2, sigOut3, sigOut4 port are the high levels

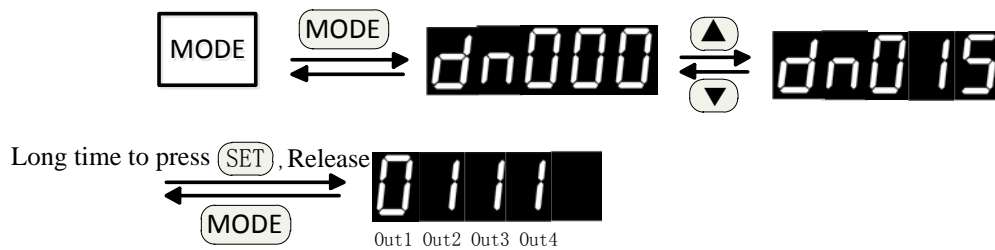

3.4 Auxiliary mode operation



Auxiliary mode function number

3.4.1 Auxiliary function list

number	instruction
Fn000	Alarm record inquires
Fn001	Permanently written to the user parameters. If users set the parameters of Pn000 ~ Pn219, For the next after power on, the drive is loaded the modify parameters by the user, you must perform this operation, the parameter block write internal EEPROM chip. After executing, need about 3 seconds, the block to write all the parameters into the EEPROM
Fn002	JOG Trial operation
Fn003	clear the current detection alarm
Fn004	The parameters of the parameter in the table Pn000 ~ Pn219, according to the setting of Pn000, restore to factory default
Fn005	Zero position deviation
Fn006	SigOut port output force, effectively under the forced state is limited to this operation 0: SigOut all ports to cancel compulsory state 1: SigOut all ports output high level 2: SigOut all ports output low level
Fn007	Simulation of torque command voltage correction
Fn008	Simulation speed reference voltage correction
Fn009	Busbar voltage correction
Fn010	temperature calibration
Fn011	Initialization alarm record
Fn012	encoder zero

3.4.2 Fn000 Alarm function query

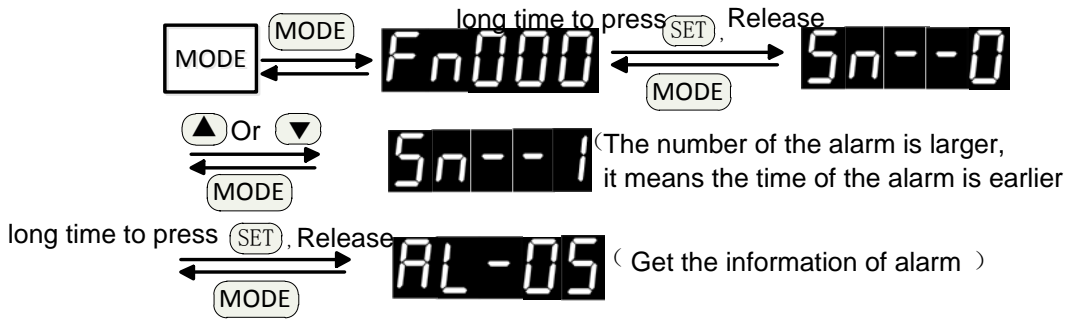

3.4.3 Fn001 Permanently written to the user parameters

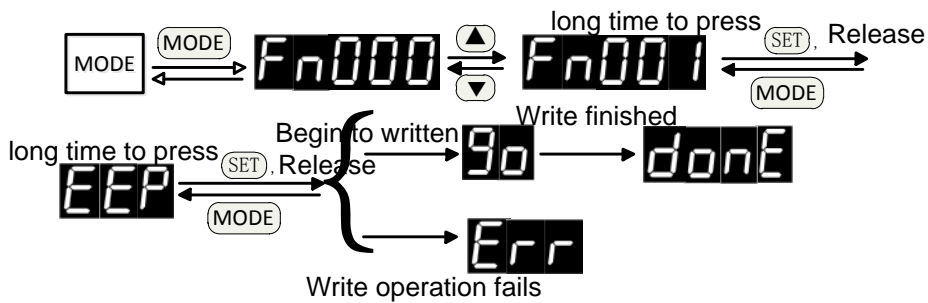

Instructions 1: if the last operation shows **Err**, may be internal drive is writing data operations performed, please wait a few seconds and try again

2: Power outages after write completint, otherwise may cause memory chip content damage (AL - 01 alarm) after the reboot,

3.4.4 Fn002 Trial operation

0:Inching mode

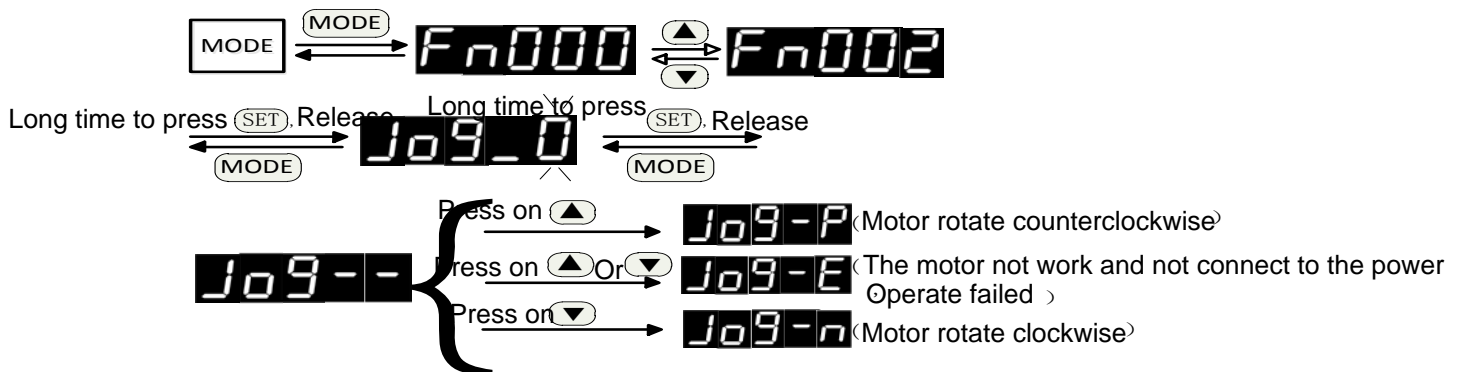

JOG The speed and deceleration time is set by the following parameters

Pn177	JOG speed	0~5000	200	r/min
Pn178	JOG speed time	5~ 10000	100	ms
Pn179	JOG deceleration time	5~ 10000	100	ms

1: Into speed control mode

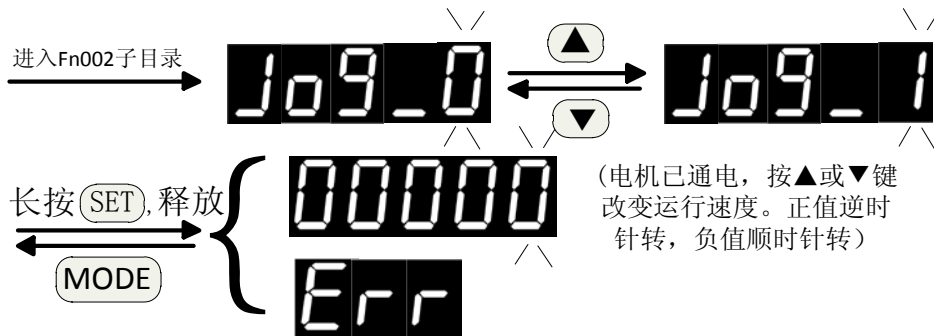

2: Exit speed control mode



operation mode	instruction
0	Inching mode. Press ▲ or ▼ button, the motor will be clockwise or counterclockwise rotation; release ▲ or ▼ button, the motor will cease to spin, in a state of no electricity
1	Electricity into speed control mode, the

	motor. Drive at a speed loop model, running speed by buttons▲ or ▼ input. In the process of the motor running, the other menu operations can be performed. If the motor stop rotating, please enter Jog_2 mode
2	Exit speed control mode, the motor is power off

Note: if the display **Jog-E** or **Err**, the possible reasons are as follows:

- 1 The motor is in the state of enabling or rotating. JOG trial run before operation, the motor must be in a non-working state. when commissioning,the control interface of the servo drive don't be connected to any control lines.
- 2 Servo driver alarm has occurred, and the alarm is not cleared.

3.4.5 Fn003 Alarm clearance operations

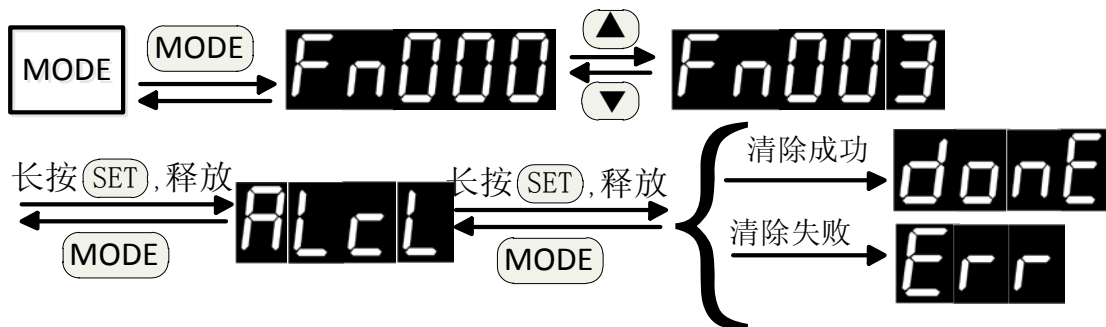

Note:When the clearance is failure at last,display **Err**,the Checked out alarm can be cleared only after power on again

Through the clear operation to clear the alarm		Electricity can remove alarm again	
AL--02	Low voltage	AL--01	Storage anomaly
AL--05	Overload 1	AL--03	overvoltage

AL--07	Motor speed is too high	AL--04	Intelligent power module is abnormal
AL--08	Heat sink is overheating	AL--06	Overload 2
AL--10	Pulse frequency is too high	AL--09	The encoder abnormal
AL--11	Pulse position deviation value is too large	AL--13	The CPU internal fault
AL--12	Current sampling circuit may be damaged	AL--17	The encoder signal frequency division output Settings abnormal
AL--14	Emergency stop	AL--18	impeoper motor code setting abnormal
AL--15	driving ban Abnormal		
AL--16	Brake average power overload		

3.4.6 Fn004 Initialization parameters

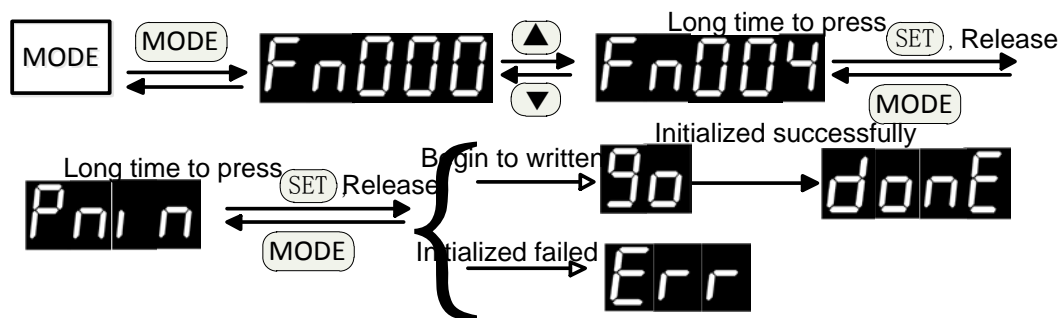

Instructions 1: if the last operation display **Err**, the possible reason as following:

- 1: Drives are executing write operations
- 2 Parameters Pn000 doesn't open the parameters initialization function

Instructions 2: must turn off the power after completing the wiring, otherwise, after the reboot, may cause memory chip content damage (AL - 01 alarm)

3.4.7 Fn005 Clear operation position deviation

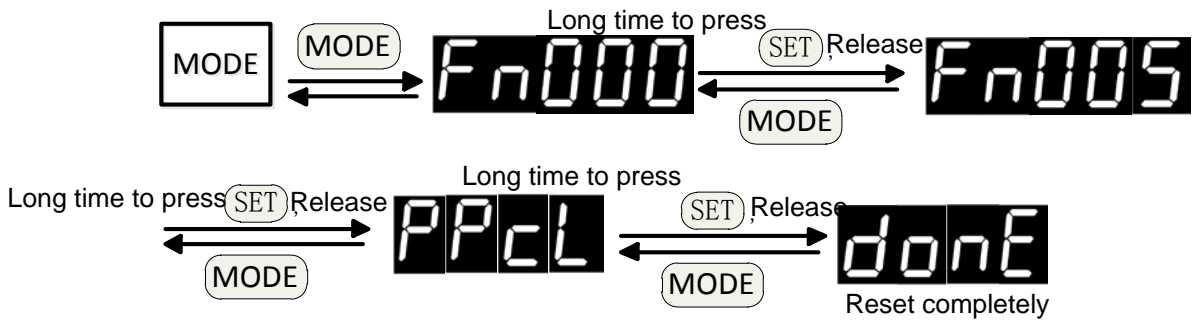

3.4.8 Fn006 The output port is mandatory

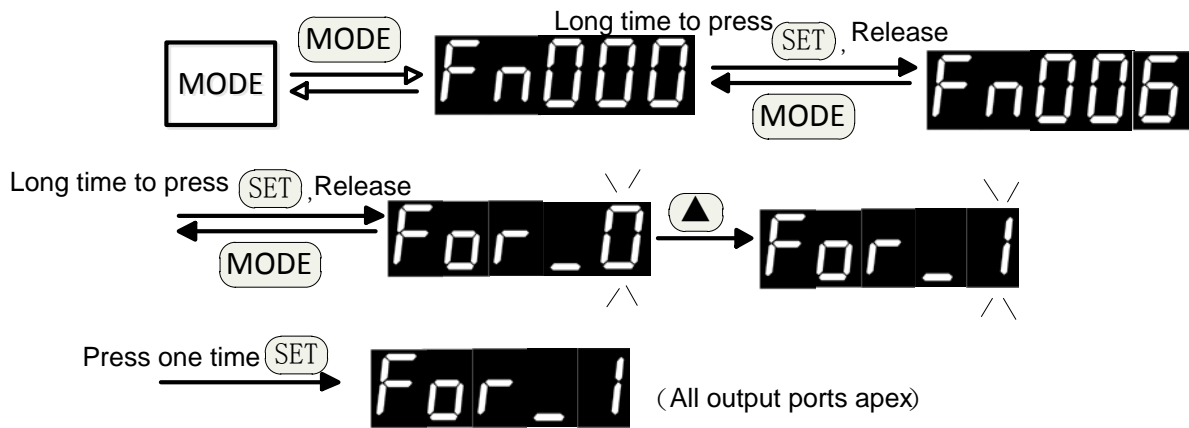

Parameter selection	instructions
0	Cancel the forced state
1	all sigoutall ports are forced high
2	all sigoutall ports are forced low

3.4.9 Fn007 Simulation of torque command voltage correction

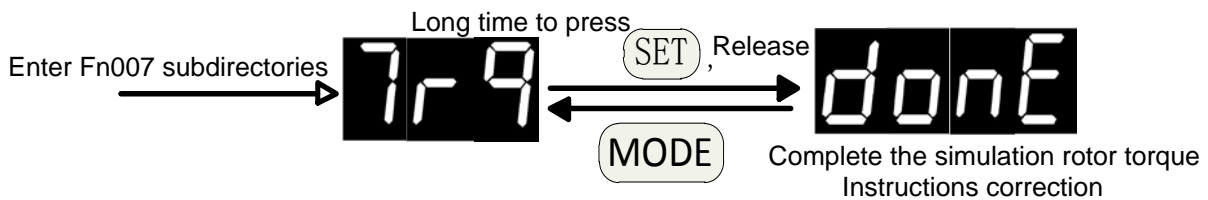

Note 1: before correcting operation, first direct short the CN2 analog voltage input port Vref (25 feet) and AGND circuit (13 feet)

3.4.10 Fn008 Simulation speed command voltage correction

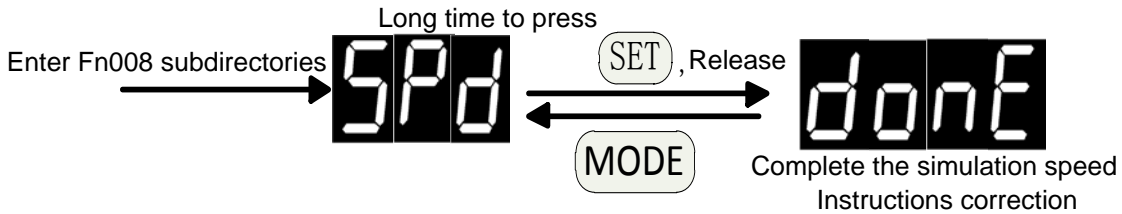

Note 1: before correcting operation, first direct short the CN2 analog voltage input port Vref (25 feet) and AGND circuit (13 feet)

3.4.11 Fn009 Busbar voltage correction

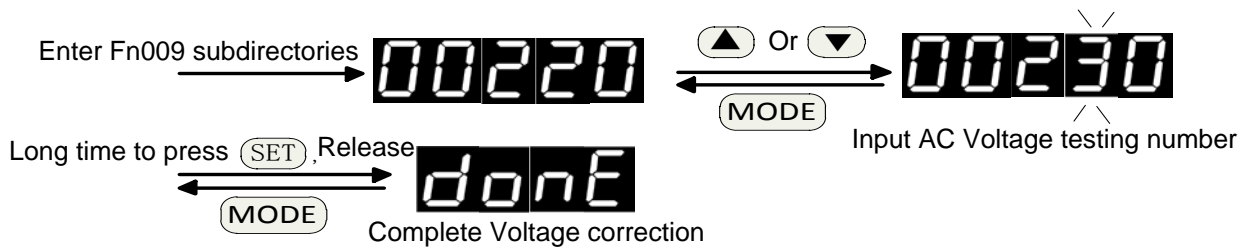

Note 1: when making correction, measurement drive input ac voltage, input to this operation.

3.4.12 Fn010 The temperature calibration

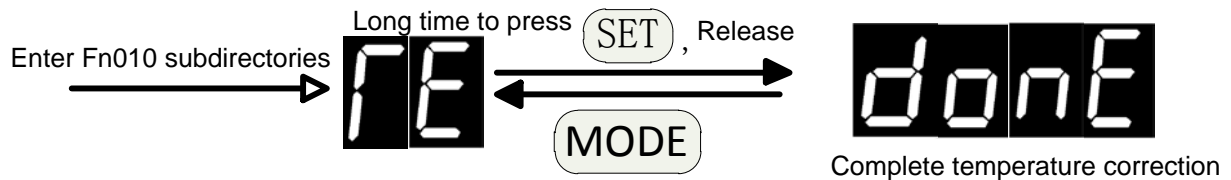

Note 1: before the operation, the temperature sensor is replaced with 1.5 K high precision resistor.

3.4.13 Fn011 Alarm record initialization

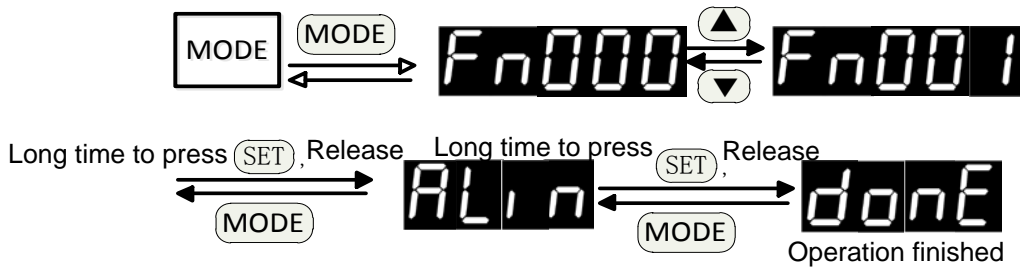

3.4.14 Fn012 The encoder zero

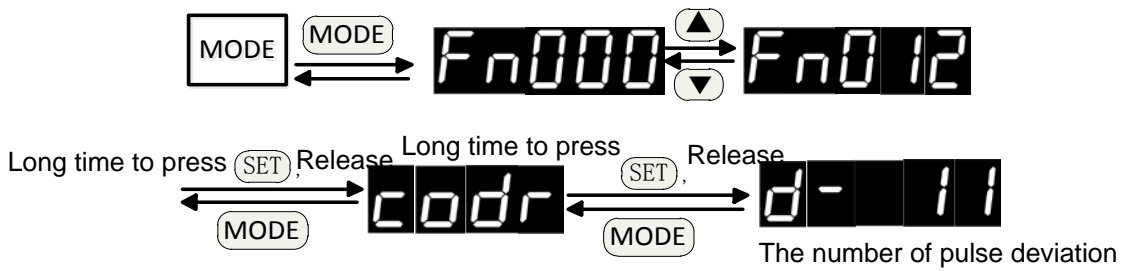

Zero before operation, confirm the motor code Pn001 set value and the actual motor model is consistent, otherwise may lead to motor current is too large, damage the motor. Adjust zero, don't need can make internal or external can make the motor, the motor will turn a few laps, and then lock the zero. When the display number of pulse bias of 0, the motor has been aimed at zero.

Note 1: if the motor heating, cooling for a period of time

3.5 User parameter mode operation



Parametric model

function number

3.5.1 Choose parameter number

Example: select Pn011 parameters

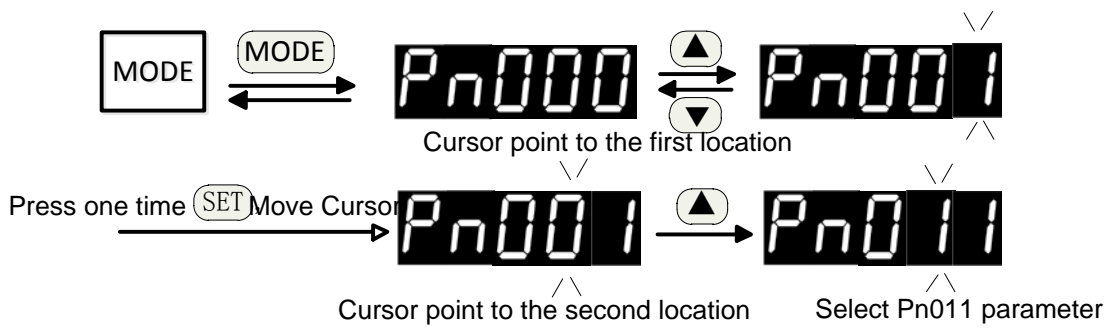

3.5.2 Edit parameters

Example: change the current value of the Pn025 parameters from 100 to 200, the specific operation is as follows:

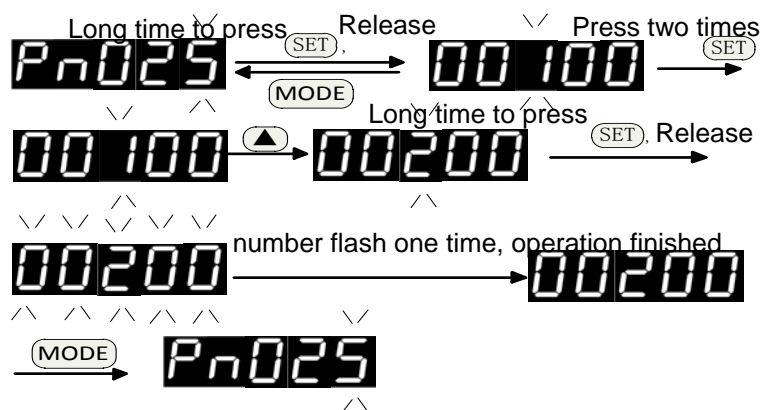

Note: Pn025 parameters are modified, if it does not have to save operation (Fn001 immortalised),

after the next to electricity, Pn025 parameters still for 100.

Chapter 4 function parameters

4.1 Parameter Settings panel operation

As shown in the third chapter of "user mode"

4.2 Parameter list

- In the column of Numbers, if any symbols ▲ , said after the parameter Settings, be it with electricity, can take effect; If symbol ◆ , said after the parameter Settings, to enable motor, parameters take effect; If no special symbols, effective immediately
- The column of applicable mode, All said is suitable for the torque, speed and position control, T is suitable for the torque control, S suitable for speed control, said P is suitable for the position control.
- Must set parameters carefully. If setting undeserved, may cause the motor running is not stable

4.2.1 System parameters

number	name	Value range	The default value	unit	apply
Pn000	Open parameters initialization function	0~2	1		All
Pn001▲	motor code	3-12	3		All
Pn002▲	control mode	0~5	2		All
Pn003	Servo enabled	0~1	0		All
Pn004	Servo broken that can stop	0~2	0		All
Pn005	Can make deceleration time	5-10000	100	ms	All
Pn006	With/without positive driving is prohibited	0-3	0		All
Pn007	Is/reverse the driver stop deceleration time is prohibited	0-10000	60	ms	All
Pn008	(CCW) Internal around are torque limit (CCW)	0-300	300	%	All

Pn009	CW) Around inside the torque limit (the CW)	-300~0	-300	%	All
Pn010	(CCW) External around are torque limit (CCW)	0-300	300	%	All
Pn011	(CW) Around outside the torque limit (the CW)	-300~0	-300	%	All
Pn012	Forward (CCW) torque overload alarm level 1	0-300	200	%	All
Pn013	Inversion (the CW) torque overload alarm level 1	-300-0	-200	%	All
Pn014	Torque overload alarm detection 1 time	0-800	80	100ms	All
Pn015	Overload 2 testing time	0-150	40	100ms	All
Pn016▲	DA The molecular DA of encoder divider output	1~63	1		All
Pn017▲	DB The denominator DB of encoder divider output	1~63	1		All
Pn018▲	Take the encoder output pulse AB phase logic	0-1	0		All
Pn019▲	Rated current Settings	0-50	0	A	All
Pn020▲	Rated speed setting	0~5000	0	r/min	All
Pn021	reach the predetermined speed	0~5000	500	r/min	All
Pn022	Hysteresis comparison difference in speed	0~5000	30	r/min	All
Pn023	Reach the predetermined speed detection direction	0-2	0		All
Pn024	Reach the predetermined torque	0-300	100	%	All

Pn025	Reach the predetermined torque hysteresis comparison difference	0-300	5	%	All
Pn026	Reach the predetermined torque direction	0-2	0		All
Pn027	Zero velocity detection range setting	0~1000	10	r/min	All
Pn028	Zero speed test back to the poor	0~1000	5	r/min	All
Pn029	Motor electromagnetic brake testing point zero speed	0~1000	5	r/min	All
Pn030	The motor stops electromagnetic brake delay time	0~2000	0	Ms	All
Pn031	The motor electromagnetic brake waiting time during operation	0~2000	500	ms	All
Pn032	The motor speed of electromagnetic brake action during operation	0-3000	30	r/min	All
Pn033	The origin is triggered	0~3	0		All
Pn034	The origin return reference point model	0~5	0		All
Pn035	The origin back to the origin model	0~2	0		All
Pn036	The origin position offset high	-9999~9999	0	hundreds of Pulse	All
Pn037	The origin position offset low	-9999~9999	0	Pulse	All
Pn038	The origin back to the first speed	1~3000	200	R/min	All
Pn039	The origin back to the second speed	1~3000	50	R/min	All

Pn040	The accelerating time of origin	5~10000	50	ms	All
Pn041	The origin return to slow down time	5~10000	50	ms	All
Pn042	The origin in the delay	0~3000	60	ms	All
Pn043	Complete signal delay of origin	5~3000	80	ms	All
Pn044	The origin of origin instruction execution mode	0~1	0		All
Pn045	Gain switch to choose	0~5	5		All
Pn046	Gain switch level	0~30000	80		All
Pn047	Gain switch back to the poor	0~30000	6		All
Pn048	Gain switch delay time	0~20000	20	0.1ms	All
Pn049◆	Gain switch time 1	0~15000	0	0.1ms	All
Pn050◆	Gain switch time 2	0~15000	50	0.1ms	All
Pn051	The motor running top speed limit	0~5000	3000		All
Pn052▲	SigIn1 port functional allocation	-27~27	1		All
Pn053▲	SigIn 2 port functional allocation	-27~27	2		All
Pn054▲	SigIn 3 port functional allocation	-27~27	19		All
Pn055▲	SigIn 4 port functional allocation	-27~27	8		All
Pn056	SigIn 1 port filtering time	1~1000	2	ms	All
Pn057	SigIn 2 port filtering time	1~1000	2	ms	All
Pn058	SigIn 3 port filtering time	1~1000	2	ms	All
Pn059	SigIn 4 port filtering time	1~1000	2	ms	All
Pn060▲	SigOut 1 port	-14~14	2		All

	functional allocation				
Pn061▲	SigOut 2 port functional allocation	-14~14	1		All
Pn062▲	SigOut 3 port functional allocation	-14~14	4		All
Pn063▲	SigOut 4 port functional allocation	-14~14	7		All
Pn064▲	Communication mode	0-2	0		All
Pn065	Communications site	1-254	1		All
Pn066▲	Communication baud rate	0-3	1		All
Pn067▲	Communication mode setting	0-8	8		All
Pn068	Input function control mode select register 1	0~32767	0		All
Pn069	Input function control mode select register 2	0~4095	0		All
Pn070	Input function logic state set register 1	0~32767	32691		All
Pn071	Input function logic state set register 2	0~4095	4095		All
Pn072	Internal use				
Pn073	Internal use				
Pn074	Fan function temperature	30~70	50	摄氏 度	All
Pn075	Fan operation mode	0~2	0		All
Pn076	Emergency stop reset (EMG)	0-1	0		All
Pn077	Positive and negative riving ban checked out	0-2	0		All
Pn078	Lack of voltage detection	0~1	1		All
Pn079	The system status display project selection	0-23	0		All
Pn080▲	The encoder to choose	0~0	0		All
Pn081	User preferences permanent write	0-1	0		All

	operation				
Pn082	SigOut port force output	0	0~255		All
Pn083	Low pressure alarm detect amplitude	50~280	200	V	All
Pn084	High pressure alarm detect amplitude	290~380V	365	V	All
Pn085▲	Motor pole logarithmic	1~100	4	对	All
Pn086	Renewable circuit discharge cycle	0~2000	70	ms	All
Pn087- pn095	Internal use	-	-	-	-

4.2.2 Position control parameters

number	name	Value range	The default value	unit	apply
Pn096▲	The command pulse input mode	0-2	0		P
Pn097▲	Instruction selection logic pulse input direction	0-1	0		P
Pn098	Pulse electronics gear than the molecules of 1	1~32767	1		P
Pn099	Pulse electronics gear than the molecules of 2	1~32767	1		P
Pn100	Pulse electronics gear than the molecules of 3	1~32767	1		P
Pn101	Pulse electronics gear than the molecules of 4	1~32767	1		P
Pn102▲	Pulse electronics gear than the	1~32767	1		P

	denominator				
Pn103	Beyond the scope of setting position deviation	1~ 500	500	Thous and pulse	P
Pn104	Complete range set position location	0~ 32767	10	pulse	P
Pn105	Positioning to complete set	0~ 32767	3	pulse	P
Pn106	Position location close to the range of Settings	0~ 32767	300	pulse	P
Pn107	Position location close to the poor set back	0~ 32767	30	pulse	P
Pn108	Position deviation clear way	0-1	1		P
Pn109◆	Position command deceleration mode	0-2	1		P
Pn110◆	Position command a filtering time constant	5~1750	50	ms	P
Pn111◆	Ta S-shaped filtering time constant Ta position instruction	5~1200	50	ms	P
Pn112◆	position instruction Ts S-shaped filtering time constant Ts	5~550	20	ms	P
Pn113▲	The position loop feedforward gain	0-100	0	%	P
Pn114▲	Position loop feedforward filter time constant	1-50	5	ms	P
Pn115	The position	5-2000	100	%	P

	controller gain 1				
Pn116	The position controller gain 2	5-2000	100	%	P
Pn117	Position command source selection	0~1	0		P
Pn118	Internal position instruction suspend mode selection	0~1	0		P
Pn119	Internal position suspended deceleration time	0~10000	50		P
Pn120	Internal position 0 high pulse number set up	-9999~9999	0	万个 脉冲 ten thous and pulse	P
Pn121	Internal position instruction 0 pulse number low set	-9999~9999	0	个 a	P
Pn122	Internal position instruction 1 pulse number high set	-9999~9999	0	万个 脉冲 ten thous and pulse	P
Pn123	Internal position instruction 1 pulse number low set	-9999~9999	0	个 a	P
Pn124	Internal position instruction 2 pulse number high set	-9999~9999	0	万个 脉冲 ten thous and pulse	P

Pn125	Internal position instruction 2 pulse number set low	-9999~9999	0	个 a	P
Pn126	Internal position instruction 3 pulse high setting	-9999~9999	0	万个 脉冲 ten thous and pulse	P
Pn127	Internal position instruction 3 pulse number set low	-9999~9999	0	个 a	P
Pn128	Internal position command zero speed	0~3000	100	r/min	P
Pn129	Internal position command 1 speed	0~3000	100	r/min	
Pn130	Internal position command 2speed	0~3000	100	r/min	P
Pn131	Internal position command 3 speed	0~3000	100	r/min	P
Pn132	Torque/speed control switch to the position control	0~1	0		P
Pn133	Torque/speed control switch to the position control of the deceleration time	5-10000	100	ms	P
Pn134~ Pn145	internal use	-	-	-	

4.2.3 Speed control parameter

number	name	value range	The default value	unit	apply
Pn146◆	Speed instruction deceleration mode	0~2	1		S
Pn147◆	Ts Speed instruction S curve and deceleration time constant Ts	5~ 1500	80	ms	S
Pn148◆	Ta Speed instruction S curve acceleration time constant of Ta	5~ 10000	80	ms	S
Pn149◆	Td Speed instruction S curve deceleration time constant of Td	5~ 10000	80	ms	S
Pn150◆	Linear acceleration time constant	5~30000	80	ms	S
Pn151◆	Linear deceleration time constant	5~30000	80	ms	S
Pn152▲	Speed detection filter time constant	1~380	10	0.1ms	All
Pn153	The speed regulator proportional gain 1	5~ 2000	100	%	All
Pn154	Speed regulator integral time constant of 1	5~ 2000	100	%	All
Pn155	The speed regulator proportional gain 2	5~ 2000	100	%	All
Pn156	Speed regulator integral time constant 2	5~ 2000	100	%	All
Pn157▲	Simulation speed instruction smoothing filtering time	1~500	1	0.1ms	S
Pn158	The directive gain simulation speed	1~1500	300	r/min/ V	S
Pn159	Simulation speed instruction offset adjustment	-5000~5000	mv		S

Pn160	Simulation speed instruction direction	0-1	0		S
Pn161	Simulation speed instruction to enforce zero range	0~1000	0	10mv	S
Pn162	Simulation speed instruction to enforce zero range limit	-1000~0	0	10mv	S
Pn163	Zero speed clamp lock mode	0-1		0	S
Pn164	Zero speed clamp is triggered	0~1		0	S
Pn165	The clamp level zero speed	0~200	6	r/min	S
Pn166	Zero speed clamp deceleration time	5~10000	50	ms	S
Pn167	Internal position controller gain	5~2000	100	%	All
Pn168	speed instruction source select	0~1	0		S
Pn169	internal speed reference 1	-5000-5000	0	R/min	S
Pn170	internal speed instruction 2	-5000-5000	0	R/min	S
Pn171	internal speed instruction 3	-5000-5000	0	R/min	S
Pn172	internal speed instruction 4	-5000-5000	0	R/min	S
Pn173	internal speed instruction 5	-5000-5000	0	R/min	S
Pn174	internal speed instruction 6	-5000-5000	0	R/min	S
Pn175	internal speed instruction 7	-5000-5000	0	R/min	S
Pn176	internal speed instruction 8	-5000-5000	0	R/min	S

Pn177	JOG speed	0~5000	200	r/min	S
Pn178	JOG speed up the time	5~ 10000	100	ms	S
Pn179	JOG Deceleration time	5~ 10000	100	ms	S
Pn180~ Pn185	internal use				

4.2.4 Torque control parameters

number	name	value range	The default value	unit	apply
Pn186	Torque command deceleration mode	0~1	0		T
Pn187▲	torque instruction near deceleration time constant	1~30000	1	ms	T
Pn188▲	Analog torque instruction smooth filtering time	1~500	1	0.1ms	T
Pn189	Analog torque instruction gain	1-300	30	%/V	T
Pn190	Analog torque instruction offset adjustment	-1500~1500	0	mv	T
Pn191	Simulation of torque command direction	0-1	0		T
Pn192	Q shaft torque regulator proportional gain is 1	5~ 2000	100	%	All
Pn193	Q shaft torque regulator integral time constant of 1	5~ 2000	100	%	All
Pn194	Proportional gain 2 Q shaft torque regulator	5~ 2000	100	%	All

Pn195	Q shaft torque regulator integral time constant 2	5~ 2000	100	%	All
Pn196	Torque Q axis filter time constant of 1	1-500	1	0.1ms	All
Pn197	Filtering time constant torque Q 2	1~500	1	0.1ms	All
Pn198	Torque control speed limit	0~4500	2500	r/min	T
Pn199	Source of limited torque control speed choice	0~2	0		T
Pn200	The internal torque 1	-300~300	0	%	T
Pn201	The internal torque 2	-300~300	0	%	T
Pn202	The internal torque 3	-300~300	0	%	T
Pn203	The internal torque 4	-300~300	0	%	T
Pn204	Torque command source	0~1	0		T
Pn205	D shaft torque regulator proportional gain	5~2000	100	%	All
Pn206	D shaft torque regulator integral time constant	5~2000	100	%	All
Pn207	Speed feedback adjustment coefficient	1~3000	100		T
Pn208	track torque instruction judgment error range 1	0~300	5	%	T
Pn209	tracking torque instruction judgment error range 2	0~300	2	%	T
Pn210~ Pn219	internal use				

4.2.5 Extension control parameters

4.3 Parameters

4.3.1 System parameters

number	name	value range	default value	unit	apply
Pn000	Open parameters initialization function	0~2	1		All

▲ 0: Open parameters initialization function

▲ 1: Allow to initialize to all parameters, but not initialized Pn001

code (motor), Pn159 (simulated speed instruction offset adjustment), Pn190 (analog torque instruction offset adjustment), and other parameter values

▲ 2: Allow to initialize all parameters

number	name	value range	default value	unit	apply
Pn001▲	Motor code	3-12	3		All

▲ Must set up the right motor type code, the motor can work normally. Drive model and motor model fit the table below

Motor model	Pn001	Rated speed (r/min)	rated torque (N.M)	Rated power (W)	KRS	KRS	KRS	KRS	KRS
					15A	20A	30A	50A	75A
60st_m00630	0	3000	0.6	200	✓	✓	✓		
60st_m01330	1	3000	1.3	400	✓	✓	✓		
60st_m01930	2	3000	1.9	600	✓	✓	✓		
80st_m01330	3	3000	1.3	400	✓	✓	✓		
80st_m02430	4	3000	2.4	750	✓	✓	✓		
80st_m03520	5	2000	3.5	730	✓	✓	✓		
80st_m04025	6	2500	4	1000	✓	✓	✓		
90st_m02430	7	3000	2.4	750	✓	✓	✓		
90st_m03520	8	2000	3.5	730	✓	✓	✓		
90st_m04025	9	2500	4	1000	✓	✓	✓		
110st_m02030	10	3000	2	600	✓	✓	✓		
110st_m04020	11	2000	4	800	✓	✓	✓		

110st_m04030	12	3000	4	1200		√	√		
110st_m05030	13	3000	5	1500			√		
110st_m06020	14	2000	6	1200	√	√	√		
110st_m06030	15	3000	6	1800			√		
130st_m04025	16	2500	4	1000	√	√	√		
130st_m06015	17	1500	6	1000	√	√	√		
130st_m05025	18	2500	5	1300		√	√		
130st_m06025	19	2500	6	1500			√		
130st_m07725	20	2500	7.7	2000			√		
130st_m10010	21	1000	10	1000	√	√	√		
130st_m10015	22	1500	10	1500		√	√		
130st_m10025	23	2500	10	2600			√	√	√
130st_m15015	24	1500	15	2300			√		
130st_m15025	25	2500	15	3800				√	√
150st_m15025	26	2500	15	3800				√	√
150st_m15020	27	2000	15	3000				√	√
150st_m18020	28	2000	18	3600				√	√
150st_m23020	29	2000	23	4700				√	√
150st_m27020	30	2000	27	5500					√
180st_m17215	31	1500	17.2	2700				√	√
180st_m19015	32	1500	19	3000			√	√	√
180st_m21520	33	2000	21.5	4500				√	√
180st_m27010	34	1000	27	2900				√	√
220st_m67010	35	1000	67	1000					√

number	name	value range	the default value	unit	apply
Pn002▲	control mode	0~5	2		All

▲ All kinds of control mode in the following table

Pn002	control mode
0	Torque mode
1	speed mode
2	location mode

3	location/speed mode
4	location/torque mode
5	speed/torque mode

▲ Set to three, four, five, mode between the switch is determined by the input port SigIn Cmode signal state

Pn002	Cmode	control mode
3	OFF	location mode
	ON	speed mode
4	OFF	location mode
	ON	torque mode
5	OFF	speed mode
	ON	toeque mode

▲ Please refer to the appendix B for switching control mode

number	name	value range	the default value	unit	apply
Pn003	Servo enabled mode	0~1	0		All

▲ 0 By the input port of the SigIn SON can drive

▲ 1 After power on can automatically make the drive

number	name	value range	the default value	unit	apply
Pn004	Servo is broken can stop the way	0~2	0		All

▲ When make the can signal from effective becomes invalid, can set the motor to stop running mode

Pn004	Electromagnetic brake	Slowing down	instructions		
0	Do not use	Do not use	Inertial parking		
1	Do not use	use	Determined by Pn005 decelerate parking, deceleration time		

2	use	Do not use	Electromagnetic braking parking with electromagnetic brake (for motor)
---	-----	------------	---

number	name	value range	the default value	unit	apply
Pn005	Can make deceleration time	5-10000	100	ms	All

▲ Can make the signal from the effective becomes invalid, the motor speed to zero time. If in the process of reduction, enabling signal effectively again, the motor will slow down to zero

number	name	value range	the default value	unit	apply
Pn006	With/without positive driving is prohibited	0-3	0		All

▲ Set this parameter values, you can choose to use or not use driving ban function, the truth table below

Pn006	Forward driving ban	Reverse driving ban
0	Do not use	Do not use
1	Do not use	use
2	use	Do not use
3	use	use

number	name	value range	the default value	unit	apply
Pn007	forward/reverse driving stop deceleration time is prohibited	0-10000	60	ms	All

▲ When happening overtravel, SigIn port CCWL or.cwl status is OFF; use Pn077 on

whether can be set up alarm detection. Distance, the motor can be in accordance with the slow time to slow down, clear position instruction pulse (position control) at the same time, after stop for internal position lock. Internal position gain through Pn167 regulation

number	name	value range	the default value	unit	apply
Pn008	Internal around are torque limit (CCW)	0-300	300	%	All
Pn009	Around inside the torque limit (the CW)	-300~0	-300	%	All
Pn010	External around are torque limit (CCW)	0-300	300	%	All
Pn011	Around outside the torque limit (the CW)	-300~0	-300	%	All

▲ Set the CCW/the CW direction of motor torque limit. Internal and external torque limit effectively at the same time, the actual torque smaller limit

▲ External torque limit by SigIn TCCWL, TCWL control of the port

▲ Some motor maximum output torque is twice the rated torque, the maximum torque of the motor output automatically restricted to within two times the rated torque

number	name	value range	the default value	unit	apply
Pn012	Forward (CCW) torque overload alarm level 1	0-300	200	%	All
Pn013	Inversion (the CW) torque overload alarm level 1	-300-0	-200	%	All

Pn014	Torque overload 1 alarm detection time	0-800	80	100ms	All
Pn015	Overload 2 testing time	0-150	40	100ms	All

▲ Overload 1 alarm level refers to the overload overcurrent rated output current percentage, relative to the motor overload capacity range between 0 and the maximum output current. Torque overload 1 the overload capacity of the default value is 2 times, in the setting time, lasts for more than 2 times the output torque, will perform overload 1 protection

▲ In a set time, the motor to allow the rated torque output ratio, will perform overload 2 protection

▲ If the overload level sets is greater than the corresponding internal/external torque limit, overload conditions may not be met, the protection will not work

number	name	value range	the default value	unit	apply
Pn016▲	The molecular DA of encoder divider output	1~63	1		All
Pn017▲	The denominator DB of encoder divider output	1~63	1		All

▲ Encoder output, a electronic gear used for dividing the encoder pulse signal output. Frequency division value must be satisfied: $DA/DB \geq 1$. Encoder, for example, to line 2500, DA/DB crossover value = $25/8$, then after frequency division line number: $2500 / (DA/DB) = 2500 / (25/8) = 800$ line

number	name	value range	the default value	unit	apply
Pn018▲	Take the encoder output pulse	0-1	0		All

	AB phase logic				
--	----------------	--	--	--	--

▲0: motor counterclockwise A, B in advance. Clockwise ahead of A B

▲1: motor counterclockwise B ahead; Clockwise ahead of B

number	name	value range	the default value	unit	apply
Pn019▲	Rated current Settings	0-15	0	A	All
Pn020▲	Rated speed setting	0~5000	Rated speed	r/min	All

▲ Parameter is set to 0, use the manufacturer to set a default value; Otherwise, the user must be strictly in accordance with the motor rated current RMS, rated speed and the corresponding internal positive and negative torque limit setting parameter values. If set incorrectly, the motor will not be able to run properly. According to the code of different types and motor drive, can achieve the largest actual current value is different. Please do not modify the average user.

number	name	value range	the default value	unit	apply
Pn021	reach to predetermined speed	0~5000	500	r/min	All
Pn022	Hysteresis comparison difference in predetermined speed	0~5000	30	r/min	All
Pn023	Reach to predetermined speed detection direction	0-2	0		All

▲ When the motor is running at a faster rate than the decision value set, the output port SigOut Sreach will turn ON, or to OFF.

▲ More instruments include

hysteresis comparison. The setting of the difference is too small, the output signal cut-off frequency is higher; The set value, the greater the cut-off frequency is small, but at the same time reduce the resolution of the comparator. Example: booking speed is set to 100, difference set to 10.

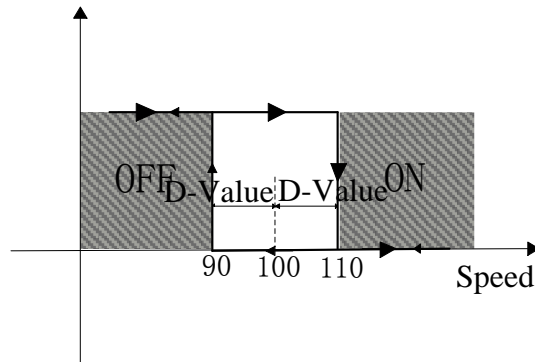

▲ Can be set up speed detection direction, in the following table

Pn023	The comparator
0	Positive & negative were detected
1	Testing only forward speed; Inversion, the signal is OFF
2	Only detect reverse speed; Forward, the signal is OFF

number	name	value range	the default value	unit	apply
Pn024	reach to the predetermined torque	0-300	100	%	All
Pn025	Reach a predetermined torque hysteresis comparison difference	0-300	5	%	All
Pn026	Reach the predetermined torque direction	0-2	0		All

▲ When the motor running torque than the decision value set, the output port SigOut Treach will turn ON, or to OFF

▲ Can install torque detection direction, in the following table:

Pn026	The comparator
-------	----------------

0	Positive &negative were detected
1	Testing is only around moment; Inversion, the signal is OFF
2	Only testing around the moment; Forward, the signal is OFF

number	name	value range	the default value	unit	apply
Pn027	Zero velocity detection range setting	0~1000	10	r/min	All
Pn028	Zero speed test back to the poor	0~1000	5	r/min	All

▲ When the speed of the motor speed is lower than the set value, the output port SigOut zerospeed into ON, otherwise to OFF

number	name	value range	the default value	unit	apply
Pn029	Motor electromagnetic brake testing point zero speed	0~1000	5	r/min	All

▲ Only when using electromagnetic brake function, state whether the motor is zero speed

number	name	value range	the default value	unit	apply
Pn030	Motor static electromagnetic brake delay time	0~2000	0	Ms	All

▲ Motor static, electromagnetic brake braking began to delay time of cut off the current to the motor

▲ When using the electromagnetic brake function, servo way can make Pn005 must be set to 2

number	name	value range	the default value	unit	apply
Pn031	The motor	0~2000	500	ms	All

	electromagnetic brake waiting time during operation				
--	---	--	--	--	--

▲ Motor operation, cut off the current to the waiting time between electromagnetic brake

number	name	value range	the default value	unit	apply
Pn032	Electromagnetic brake movement speed while the machine running	0-3000	30	r/min	All

▲ Motor operation, when the speed of motor is lower than the set parameters, magnetic brakes brake

number	name	value range	the default value	unit	apply
Pn033	The origin is triggered	0~3	0		All

▲ 0: Close the origin regression function

▲ 1 By the input port of the SigIn GOH level trigger

▲ 2 By the input port of the SigIn GOH rising along the trigger

▲ 3 Power on automatically

▲ See the appendix F origin point execution way

number	name	value range	the default value	unit	apply
Pn034	The origin return reference point model	0~5	0		All

▲ 0: Forward looking for REF (rising along the trigger) as a reference point

▲ 1: Inversion for REF (rising along the trigger) as a reference point

▲ 2: Forward looking for CCWL falling edge (trigger) as a reference point

▲ 3 Inversion to find.cwl falling edge (trigger) as a reference point

▲ 4: Forward looking for Z pulse as a reference point

▲ 5: Pulse inversion for Z as a reference point

Note: CCWL or.cwl as a reference point, need to set the Pn006 parameters, open the function

number	name	value range	the default value	unit	apply
Pn035	The origin back to the origin model	0~2	0		All

- ▲ 1 Backward looking for Z pulse as the origin
- ▲ 2 Forward looking for Z pulse as the origin
- ▲ 3 Directly with reference point rise along the origin

number	name	value range	the default value	unit	apply
Pn036	The origin position offset high	-9999~9999	0	ten thousand pulse	All
Pn037	The origin position offset low	-9999~9999	0	pulse	All

- ▲ After finding the origin, plus the offset (10000 + Pn037 Pn036 *) as a real origin

number	name	value range	the default value	unit	apply
Pn038	The origin back to the first speed	1~3000	200	R/min	All
Pn039	The origin back to the second speed	1~3000	50	R/min	All

- ▲ Perform operation on the origin, looking for reference points at the first speed, arrived at the reference point, seeking the origin at the second rate. The second speed should be less than the first speed

number	name	value range	the default value	unit	apply
Pn040	The accelerating time of origin	5~10000	50	ms	All
Pn041	The origin return to slow down time	5~10000	50	ms	All

- ▲ In the execution of origin point, motor from zero speed accelerated to the rated speed of the time, only for the origin returning operation

	name	value	the	unit	
--	------	-------	-----	------	--

number		range	default value		apply
Pn042	The origin in the delay	0~3000	60	ms	All

- ▲ On arriving at the origin, the delay for a period of time, let the motor is perfectly still. After the completion of the delay, output port SigOut HOME output ON

number	name	value range	the default value	unit	apply
Pn043	Complete the signal delay of origin	5~3000	80	ms	All

- ▲ HOME last valid time

number	name	value range	the default value	unit	apply
Pn044	The origin return instruction execution mode	0~1	0		All

- ▲ 0 After the completion of the origin, waiting for the HOME signal into OFF to receive and executes instructions

- ▲ 1 The origin return immediately after the completion of receiving and executes instructions

number	name	value range	the default value	unit	apply
Pn045	Gain switch to choose	0~5	5		All

- ▲ 0: Fixed gain 1

- ▲ 1: Fixed gain 2

- ▲ 2: Controlled by input port SigIn Cgain terminals, OFF as gain 1, ON 2 gain

- ▲ 3: Controlled by speed command, speed command exceeds Pn046, switch to gain 1

- ▲ 4: Controlled by pulse bias, position deviation exceeds Pn046, switch to gain 1

- ▲ 5: By the motor speed control, feedback speed exceeds Pn046, switch to gain 1

▲ See the appendix A for gain switch

number	name	value range	the default value	unit	apply
Pn046	Gain switch level	0~30000	80		All
Pn047	Gain switch back to the poor	0~30000	6		All

▲ According to Pn045 parameter setting, switching condition and the unit is not the same

Pn044	Gain switching conditions	unit
3	Speed instruction	R/min
4	Pulse bias	a pilse
5	Motor speed	r/min

number	name	value range	the default value	unit	apply
Pn048	Gain switch delay time	0~20000	20	0.1ms	All

▲ Gain switching conditions meet the delay time to start switch. If detected in delayed phase switching conditions are not met, then cancel the switch

number	name	value range	the default value	unit	apply
Pn049◆	Gain switch time 1	0~15000	0	0.1ms	All
Pn050◆	Gain switch time 2	0~15000	50	0.1ms	All

▲ Gain switch, current gain linear smoothing gradient combination in this time to the target gain combination, combination of the various parameters change at the same time

number	name	value range	the default value	unit	apply
Pn051		0~5000	3000		All

	The motor running top speed limit				
--	-----------------------------------	--	--	--	--

- ▲ Used to restrict the highest speed of the motor running. Value should be less than or equal to the rated speed, otherwise the motor can run a maximum speed of the rated speed

number	name	value range	the default value	unit	apply
Pn052▲	SigIn1 port functional allocation	-27~27	1		All
Pn053▲	SigIn2port functional allocation	-27~27	2		All
Pn054▲	SigIn3 port functional allocation	-27~27	19		All
Pn055▲	SigIn4 port functional allocation	-27~27	8		All

- ▲ 1: Specific functional allocation reference SigIn function, a table
- ▲ 2: -1 ~ 27 function number is 1-27 corresponding negative logic function, function is the same, the effective level instead

Parameter values	SigIn input level	SigIn corresponding function
positive values	low level	ON
	high level	OFF
negative	low level	OFF
	high level	ON

- ▲ 3 If the same overlapped functions assigned to different port, the port number of ports real effective, small number of port doesn't work. Example: SigIn1 - > 6; SigIn - > 3-6; The functions assigned to SigIn 3, 6 and logic is negative, and SigIn 1 port status is ignored

number	name	value range	the default value	unit	apply
Pn056	SigIn filtering time 1 port	1~1000	2	ms	All
Pn057	SigIn filtering time 2 port	1~1000	2	ms	All

Pn058	SigIn filtering time 3 port	1~1000	2s	ms	All
Pn059	SigIn filtering time 4 port	1~1000	2	ms	All

▲ For digital filter input port SigIn

number	name	value range	the default value	unit	apply
Pn060▲	SigOut1 port functional allocation	-14~14	2		All
Pn061▲	SigOut2port functional allocation	-14~14	1		All
Pn062▲	SigOut3 port functional allocation	-14~14	4		All
Pn063▲	SigOut4port functional allocation	-14~14	7		All

▲ Specific functional allocation reference to SigOut function, a table.

Parameter values	Corresponding function	SigOut output
positive values	ON	low level
	OFF	high level
negative	OFF	low level
	ON	high level

number	name	value range	the default value	unit	apply
Pn064▲	Communication mode	0-2	0		All

▲ 0: No communication

▲ 1: RS-232

▲ 2: RS-485

▲ See chapter 7 Modbus communication protocol communication function

number	name	value range	the default value	unit	apply
Pn065	Communications site	1-254	1		All

- ▲ When using the Modbus communication, drive in each group should be set in advance different sites; If repeat setting site, will lead to paralysis of communication

number	name	value range	the default value	unit	apply
Pn066▲	Communication baud rate	0-3	1		All

▲ 0 : 4800

▲ 1 : 9600

▲ 2 : 19200

▲ 3 : 38400

number	name	value range	the default value	unit	apply
Pn067▲	Communication mode setting	0-8	8		All

▲ Parameter values are defined as follows table, see chapter 7 of the Modbus communication function

set	instructions
0	7 , N , 2 (Modbus , ASCII)
1	7 , E , 1 (Modbus , ASCII)
2	7 , O , 1 (Modbus , ASCII)
3	8 , N , 2 (Modbus , ASCII)
4	8 , E , 1 (Modbus , ASCII)
5	8 , O , 1 (Modbus , ASCII)
6	8 , N , 2 (Modbus , RTU)
7	8 , E , 1 (Modbus , RTU)
8	8 , O , 1 (Modbus , RTU)

number	name	value range	the default value	unit	apply
Pn068	Choose to register 1 input function control way	0~32767	0		All
Pn069	Choose to register 2 input	0~4095	0		All

	function control way				
--	----------------------	--	--	--	--

▲ Determine the function or port input mode control by way of communication. If you don't communicate mode control, set the zero

Pn068 parameters

bit	BIT7	BIT6	BIT5	BIT4	BIT3	BIT2	BIT1	BIT0
function	Zero Lock	EMG	TCW	TCCW	CWL	CCWL	Alarm rst	Son
The default value	0	0	0	0	0	0	0	0

BIT15	BIT14	BIT13	BIT12	BIT11	BIT10	BIT9	BIT8
keep	Cgain	Cmode	TR2	TR1	Sp3	Sp2	Sp1
0	0	0	0	0	0	0	0

Pn069 parameters

bit	BIT7	BIT6	BIT5	BIT4	BIT3	BIT2	BIT1	BIT0
function	REF	GOH	PC	INH	Pclear	Cinv	Gn2	Gn1
The default value	0	0	0	0	0	0	0	0

BIT15	BIT14	BIT13	BIT12	BIT11	BIT10	BIT9	BIT8
keep	keep	keep	keep	pstop	ptriger	Pos2	Pos1
0	0	0	0	0	0	0	0



When the communication control, determine the above function from the input port or on the CN3 from c
ommunication control to change. Set to 0, the

controlled by the input port on the CN3 change; Is set to 1, is controlled by the communication change. The

default all controlled by the input port. For example: son sp3 sp2 sp1 function through communication

control, other control, through the input port is set value is 00000111_00000001 (binary) -- -> 0 x0701

(hexadecimal) -- -> 1793 (decimal), so set Pn065 parameter value is 1793.

number	name	value range	the default value	unit	apply
--------	------	-------------	-------------------	------	-------

Pn070	Input function logic state set register 1	0~32767	32691		All
Pn071	Input function logic state set register 2	0~4095	4095		All

▲ On RS232 or RS485 communication,
and set the Pn068, Pn069 corresponding controlled by communication, this parameter with the
corresponding bit to set or reset, can control the state of the function of input signal. Logic 0 for valid state.

Pn070 parameters

bit	BIT7	BIT6	BIT5	BIT4	BIT3	BIT2	BIT1	BIT0
function	ZeroLock	EMG	TCW	TCCW	CWL	CCWL	Alarmrst	Son
The default value	1	0	1	1	0	0	1	1

BIT15	BIT14	BIT13	BIT12	BIT11	BIT10	BIT9	BIT8
keep	Cgain	Cmode	TR2	TR1	Sp3	Sp2	Sp1
0	1	1	1	1	1	1	1

Pn071 parameters

bit	BIT7	BIT6	BIT5	BIT4	BIT3	BIT2	BIT1	BIT0
Function signal	REF	GOH	PC	INH	Pclear	Cinv	Gn2	Gn1
The default value	1	1	1	1	1	1	1	1

BIT15	BIT14	BIT13	BIT12	BIT11	BIT10	BIT9	BIT8
keep	keep	keep	keep	pstop	ptriger	Pos2	Pos1
0	0	0	0	1	1	1	1

▲ In a communication control mode, by setting the register, CN3 external input signal control could be achieved.
Drive in position control mode, for example, to

ban pulse command, set Pn071 BIT4 set 0, input pulse becomes invalid. The communication control, set the parameter value, shall be invalid.

Note: after each access to electricity, drive will automatically load the Pn070, Pn071 register values, and perform the corresponding operation immediately. So, before enabling the motor to determine the function of input signal into the proper working condition

number	name	value range	the default value	unit	apply
Pn074	Fan temperature	30~70	50	°C	All
Pn075	Fan operation mode	0~2	0		All

- ▲ Fan operation mode are:
- 0: heat automatically
 - 1: boot operation
 - 2: don't run

number	name	value range	the default value	unit	apply
Pn076	Emergency stop reset (EMG)	0-1	0		All

- ▲ Lift its state of EMG OFF after the removal of EMG (AL -14) alarm conditions:

0 Must be under the servo can make OFF, by manual or port SigIn: AlarmRst cleared.

1 Regardless of servo enabled ON or OFF, EMG again into ON, will be automatically removed

- ▲ In can make ON the state, if the external command input, EMG alarm automatically remove, instructions are executed immediately

number	name	value range	the default value	unit	apply
Pn077	Is/the driving ban checked out	0-2	0		All

- ▲ If use the function of CCWL or.cwl, when CCWL or.cwl for the OFF state, whether can be set up from AL -15 police

0 Don't send out alarm

1 Motor is running, reducing stopped, send out alarm, motor is no longer current

2 Immediately issued a warning, motor power, free downtime

number	name	value range	the default value	unit	apply
Pn078	Lack of voltage detection	0~1	1		All

▲ 0 not check out

▲ 1 Check out

number	name	value range	the default value	unit	apply
Pn079	The system status display project selection	0-23	0		All

▲ Drive, automatic Dn000 submenu into monitor mode menu. By default, according to the manufacturer to display the system status (motor speed), the user can set the parameter value, so it shows Dn000 particular state of the system parameters, details see the list of "monitoring mode".

0 The default system (motor speed) 1 Speed instruction 2 The average torque 3 Position deviation value
 4 The ac power voltage 5 Maximum instantaneous torque 6 Pulse input frequency 7 Temperature of the heat sink 8 The current motor speed 9 Effective input command pulse accumulative total value is low
 10 Effective input command pulse accumulative total value is high 11 Position control, effective feedback pulse encoder accumulative total value is low 12 Position control, effective feedback pulse encoder cumulative value high 13 Regenerative braking load factor 14 Input port signal state 15 Signal output port state
 16 Analog voltage torque instruction 17 Simulate the speed reference voltage 18 Output function status register
 19 After power on the servo, pulse encoder feedback accumulative total value is low
 20 After power on the servo, pulse encoder feedback accumulative total value is high
 21 Driver soft ware 22 encoder UVW letter 23 rotor absolute position

number	name	value range	the default value	unit	apply
Pn080▲	The encoder to choose	0~1	0		All

▲ 0: Incremental encoder 2500 line

▲ 1: Absolute encoder 130000 line

number	name	value range	the default value	unit	apply
Pn081	User preferences permanent write operation	0-1	0		All

- ▲ The corresponding auxiliary mode Fn001 operation. The current Pn000 ~ Pn219 block all parameter value written to the EEPROM. When the parameter value from 0 to 1, the driver will perform a write operation. This operation is only valid at the time of communication (Pn064 > 0)

number	name	value range	the default value	unit	apply
Pn082	SigOut port output	0	0~255		All

- ▲ Mandatory SigOut port output fixed level. By setting the parameters, the force output port level

	keep	SigOut4		SigOut3		SigOut2		SigOut1	
bit	BIT15~BIT8	BIT7	BIT6	BIT5	BIT4	BIT3	BIT2	BIT1	BIT0
The default value	0	0	0	0	0	0	0	0	0

Output port truth table below

SigOut 2			SigOut 1		
BIT3	BIT2	Output level	BIT1	BIT0	Output level
0	0	Optional state	0	0	Optional state
0	1	Forced to high level	0	1	Forced to high level
1	0	Forced to low level	1	0	Forced to low level
1	1	Optional state	1	1	Optional state

SigOut 4			SigOut 3		
BIT7	BIT6	Output level	BIT5	BIT4	Output level
0	0	Optional state	0	0	Optional state

0	1	Forced to high level	0	1	Forced to high level
1	0	Forced to low level	1	0	Forced to low level
1	1	Optional state	1	1	Optional state

Example: output port SigOut2 force output low level, other optional output port status, setting Pn082 parameter value is 8.

number	name	value range	the default value	unit	apply
Pn083	Low pressure alarm detect amplitude	50~280	200	V	All

▲ When the bus voltage is less than the amplitude, the Pn078 decided whether to send out alarm

number	name	value range	the default value	unit	apply
Pn084	High pressure alarm detect amplitude	290~380V	365	V	All

▲

When the bus voltage is higher than the amplitude, immediately issued a warning, in order to protect the internal electronic components. Input power supply voltage should be within the specifications of the acceptable, if slightly on the high side, can be appropriately increase amplitude detection. If the input voltage power supply has been far beyond specification, shall not increase the parameter value, otherwise it will damage the driver, please conform to the specifications of the power supply.

number	name	value range	the default value	unit	apply
Pn085▲	Motor pole logarithmic	1~100	4	对	All

number	name	value range	the default value	unit	apply
Pn086	Renewable circuit discharge cycle	0~2000	70	ms	All

▲ When the servo motor running in generator mode, renewable electricity too

much, must through the regeneration way discharge, otherwise the internal voltage is too high, damage to the drive. Set up, the longer the voltage release faster, but the greater the power needed for regenerative resistor, otherwise easy to burn regenerative resistor. See appendix E specific Settings.

4.3.2 Position control parameters

number	name	value range	the default value	unit	apply
Pn096▲	The command pulse input mode	0-2	0		P
Pn097▲	Instruction selection logic pulse input direction	0-1	0		P

▲ Command pulse input mode in the following table:

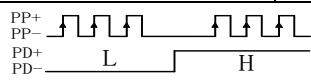
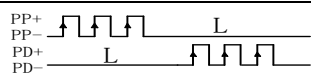
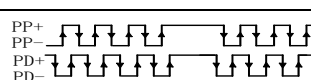
Pn096		Forward command	reverse command
0	Pulse + direction		
1	Forward/reverse pulse		
2	The orthogonal pulse		

▲ Pn097 = 0: input command, the motor rotate counterclockwise (CCW)

Pn097 = 1: input command, motor rotate clockwise (included)

number	name	value range	the default value	unit	apply
Pn098	Pulse electronics gear than the molecules of 1	1~32767	1		P
Pn099	Pulse electronics gear than the molecules of 2	1~32767	1		P
Pn100	Pulse electronics gear than the molecules of 3	1~32767	1		P

Pn101	Pulse electronics gear than the molecules of 4	1~32767	1		P
Pn102▲	Pulse electronics gear than the denominator	1~32767	1		P

▲ Electronic gear ratio must meet the following conditions, otherwise will not work:

Electronic gear or less than 1/127 of 127 or less

▲ Electronic gear than the molecules of N by the input port of the SigIn GN1, GN2 decision.

The denominator is fixed. Molecules to choose in the following table:

GN2	GN1	Electronic gear than N
OFF	OFF	Molecular 1
OFF	ON	Molecular 2
ON	OFF	Molecular 3
ON	ON	Molecular 4

number	name	value range	the default value	unit	apply
Pn103	Beyond the scope of setting position deviation	1~ 500	50	Thousands p of Pulse	

▲ Deviation when the pulse counter pulse count more than the value set (i.e., the current position and

target location are too large), drive out alarm signal.

number	name	value range	the default value	unit	apply
Pn104	Complete range set position location	0~ 32767	10	pulse	P
Pn105		0~ 32767	3	pulse	P

	Positioning to complete set				
--	-----------------------------	--	--	--	--



While the rest of the deviation counter pulse number is lower than the parameters setting, output port SigOut Preach signal is ON, or OFF.

number	name	value range	the default value	unit	apply
Pn106	Position location close to the range of Settings	0~ 32767	300	Pulse	P
Pn107	Position location close to the poor set back	0~ 32767	30	Pulse	P



While the rest of the deviation counter pulse number is lower than the parameters setting, output port SigOut Pnear signal is ON, or OFF.

编号 number	name	value range	the default value	unit	apply
Pn108	Position deviation clear way	0-1	1		P

▲ Position control, can use SigIn Pclear function, clear position deviation value of the counter.

Position deviation clearance in -

0: Pclear level ON period

1: Pclear rise along time (from OFF to ON)

number	name	value range	the default value	unit	apply
Pn109◆	Position command deceleration mode	0-2	1		P

▲ 0 Do not use the filter

▲ 1 A smoothing filter

▲ 2 S-shaped filtering

number	name	value range	the default value	unit	apply
Pn110◆	Position command s-shaped	5~1750	50	ms	P

	filtering time constant				
Pn111◆	Ta S-shaped filtering time constant Ta position instruction	5~1200	50	ms	P
Pn112◆	Ts S-shaped filtering time constant Ts position instruction	5~550	20	ms	P



Filter time constant is defined by the current location instructions frequency operation to the target frequency. Filtering, the longer the better position instruction frequency smoothness, but command the greater the response delay. In instruction pulse frequency step change, have the effect of smooth running motor. The filter has no effect on instruction pulse number.



Filtering time $T = T_a + T_s$. T_a : straight line part of the time, the smaller the T_a , the faster the deceleration. T_s : arc part time, T_s , the greater the speed is smooth, the smaller the impact.

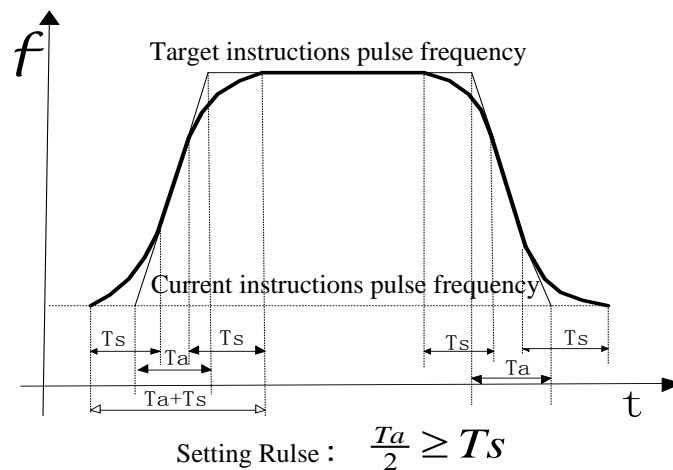

number	name	value range	the default value	unit	apply
Pn113▲	The position loop feedforward gain	0-100	0	%	P
Pn114▲	Position loop feedforward filter time constant	1-50	5	ms	P



Position control, position feedforward directly on the speed instruction, can reduce the position tracking error, improve the response. If the feedforward gain is too big, can lead to speed overshoot. To smooth the feedforward commands.

number	name	value range	the default value	unit	apply
Pn115	The position controller gain 1	5-2000	100	%	P
Pn116	The position controller gain 2	5-2000	100	%	P



In

mechanical systems do not produce under the premise of vibration or noise, increase the position loop gain value, to speed up the reaction rate, shorten the positioning time.

number	name	value range	the default value	unit	apply
Pn117	Position command source selection	0~1	0		P

▲ 0 The external input pulse

▲ 1 Internal location instructions (see appendix G)

number	name	value range	the default value	unit	apply
Pn118	Internal position instruction suspend mode selection	0~1	0		P

▲ 0 When pstop the trigger action, ptriger trigger again, according to the currently selected internal drive position command to run.

▲ 1 When pstop the trigger action, ptriger trigger again, drive to continue to complete the last remaining internal position command pulse number.

number	name	value range	the default value	unit	apply
Pn119	Internal position suspended deceleration time	0~10000	50		P

- ▲ Falling edge position in internal control, pstop, motor by the current running speed will slow down to zero, the deceleration time can be set by this parameter (only for internal position control).

number	name	value range	the default value	unit	apply
Pn120	Internal position 0 high pulse number set up	-9999~9999	0	ten thousand pulse	P
Pn121	Internal position 0 low pulse number set up	-9999~9999	0	↑	P
Pn122	Internal position 1 high pulse number set up	-9999~9999	0	ten thousand pulse	P
Pn123	Internal position 1 low pulse number set up	-9999~9999	0	piece	P
Pn124	Internal position 2 high pulse number set up	-9999~9999	0	ten thousand pulse	p
Pn125	Internal position 2 low pulse number set up	-9999~9999	0	piece	P
Pn126	Internal position 3 high pulse number set up	-9999~9999	0	ten thousand pulse	P
Pn127	Internal position 3 low pulse number set up	-9999~9999	0	↑	P

- ▲ Internal location instructions N (pulse) = internal position number N pulse high value x 10000 + internal position instruction N pulse number value low

- ▲ Example: the encoder 2500 line, to go travel 12.5 turn, is set Pn120 = 12, Pn121 = 5000.

number	name	value range	the default value	unit	apply
Pn128	Internal position command zero speed	0~3000	100	r/min	P
Pn129	Internal position command 1 speed	0~3000	100	r/min	
Pn130	Internal position command 2 speed	0~3000	100	r/min	P
Pn131	Internal position command 3 speed	0~3000	100	r/min	P

▲ When performing internal position instruction N, restrict the highest speed of motor can run.

number	name	value range	the default value	unit	apply
Pn132	Torque/speed control switch to the position control	0~1	0		P

▲ Control mode from the speed/torque mode conversion to position control

(Pn002 = 3 or 4), to avoid severe mechanical shock, should be in low speed switching.

The conditions of the switch can be set up:

Pn132=0: zerospeed)

Pn132=1: Slow down to zero

number	name	value range	the default value	unit	apply
Pn133	Torque/speed control switch to the position control of the deceleration time	5-10000	100	ms	P

▲ Pn132 = 1, when cmode signals effectively, the order control

mode by the torque/speed control switch to the position control, motor slow down to zero, then switch to the position control mode. Please refer to the appendix B for specific timing.

4.3.3 Speed control parameter

number	name	value range	the default value	unit	apply
Pn146◆	Speed instruction deceleration mode	0~2	1		S

▲ Pn146=0: Do not use the speed instruction deceleration function

Pn146=1: Using the speed instruction S curve deceleration function

Pn146=2: Use linear deceleration function

▲In speed control mode and the external position loop, this parameter must be set to 0.

number	name	value range	the default value	unit	apply
Pn147◆	Speed instruction S curve and deceleration time constant Ts	5~ 1500	80	ms	S
Pn148◆	Speed instruction S curve acceleration time constant of Ta	5~ 10000	80	ms	S
Pn149◆	Speed instruction S curve deceleration time constant of Td	5~ 10000	80	ms	S

▲ In speed control mode, you can set the speed instruction, deceleration time, in order to smoothly to start and stop the servo motor.

▲ Ta: acceleration time: from 0 r/min to rated speed. For

example, servo motor rated speed 3000 r/min, if the setting time is 3 s, accelerate from 0 r/min to 1000 r/min for 1 s.

Td: Deceleration time: by the rated speed reduced to 0 r/min

Ts: Arc part time

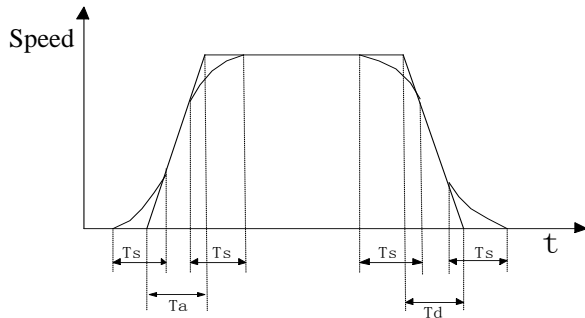

Setting Rules : $\frac{T_a}{2} \geq T_s, \frac{T_d}{2} \geq T_s$

number	name	value range	the default value	unit	apply
Pn150◆	Linear acceleration time constant	5~30000	80	ms	S
Pn151◆	Linear deceleration time constant	5~30000	80	ms	S

▲ Accelerating time constant is defined as the speed instruction from zero to rated speed.

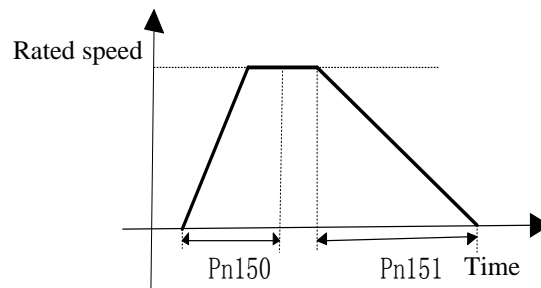

number	name	value range	the default value	unit	apply
Pn152▲	Speed detection filter time constant	1~380	10	0.1ms	All

▲ The smooth the speed of the parameter value, the greater the detected, but lead to the slower speed response. Too easy to cause the oscillation, too small may lead to noise.

number	name	value range	the default value	unit	apply
--------	------	-------------	-------------------	------	-------

Pn153	The speed regulator proportional gain 1	5~ 2000	100	%	All
Pn154	Speedregulator integral time constant of 1	5~ 2000	100	%	All
Pn155	The speed regulator proportional gain 2	5~ 2000	100	%	All
Pn156	Speed regulator integral time constant 2	5~ 2000	100	%	All

▲ Speed loop controller gain directly determine the response of the speed control loop bandwidth, the mechanical system without vibration or noise, increase the speed loop gain value, accelerated the response.

▲ Integral time constant is used to adjust the steady-state error compensation rate, decrease the parameter values, reduce the speed control error, increase rigidity. Is too small easy to cause vibration and noise.

number	name	value range	the default value	unit	apply
Pn157▲	Simulation speed instruction smoothing filtering time	1~500	1	0.1ms	S

▲ The set value, the greater the input analog response speed is slow, is beneficial to reduce the high frequency noise, setting is smaller, the faster response speed, but will get big interference noise.

number	name	value range	the default value	unit	apply
Pn158	The directive gain simulation speed	1~1500	300	r/min/V	S

▲ Analog speed reference input and the ratio between the actual speed motor. The range of input voltage - 10 ~ 10 v. Formula: speed = * Pn158 input voltage. For example: when the input voltage of 10 v, if set to 300, the corresponding rate of 10 * 300 = 3000 r/min.

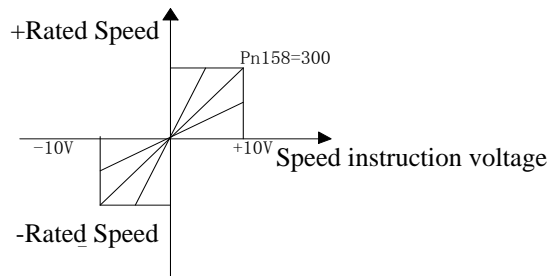

number	name	value range	the default value	unit	apply
Pn159	Simulation speed instruction offset adjustment	-5000~5000	mv		S

▲ May occur in the analog input offset phenomenon, can through this parameter.

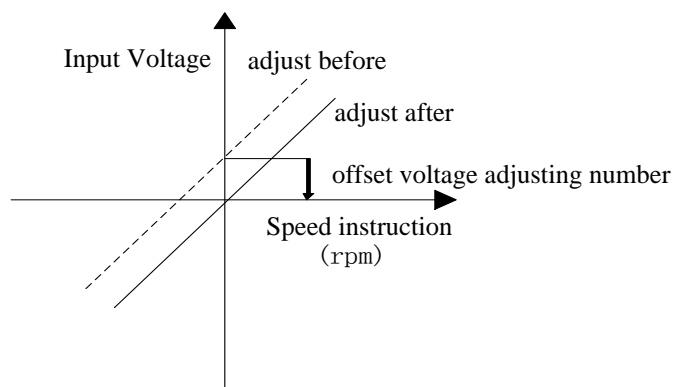

▲ Automatic offset adjusting, perform Fn008 operations.

▲ Manually adjust the migration steps are as follows:

1 The external zero potential access to the analog input port

2 This parameter is zero, the monitor dn17 shows the value of the model.

3 If observed values are not zero, negative observation value to the input parameters, can be realized to adjust (note that the voltage unit conversion relationship).

Example: dn17 = 1.12 V, Pn159 input - 1120 mv.

number	name	value range	the default value	unit	apply
Pn160		0-1	0		S

	Simulation speed instruction direction				
--	--	--	--	--	--

- ▲ 0 Positive voltage forward (CCW), negative voltage inversion (the cw)
- ▲ 1 Positive voltage forward (CCW), negative voltage inversion (the cw)

number	name	value range	the default value	unit	apply
Pn161	Simulation speed instruction to enforce zero range	0~1000	0	10mv	S
Pn162	Simulation speed instruction to enforce zero range	-1000~0	0	10mv	S

- ▲ Input speed instruction lies between floor and ceiling, forced to 0 V input instructions.

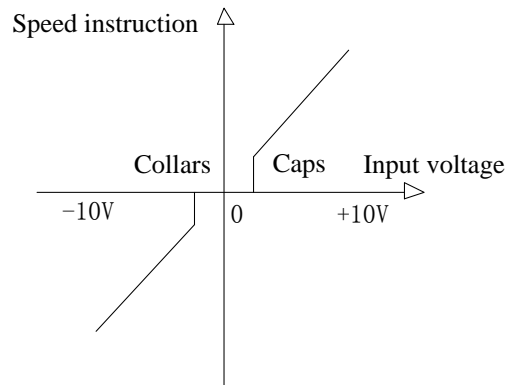

- ▲ When the input voltage is after adjusting for PN159 offset of the input voltage.
- ▲ Through the upper and lower set, can make the input instructions into a single polarity, double polarity. Example: the upper limit of 0, lower limit for - 1000, the equivalent input command range of 0 ~ 10 v, for normal polarity speed commands.

number	name	value range	the default value	unit	apply
Pn163	Zero speed clamp lock mode	0-1		0	S

▲ 0: Lock, the clamping position loop control is the mode, involved in internal ring loop control, gain by Pn167 Settings.

▲ 1 Locked, clamping way is speed loop control, speed instruction forced to 0, location may change due to external force.

number	name	value range	the default value	unit	apply
Pn164	Zero speed clamp is triggered	0~1		0	S

▲ 0: SigIn port ZeroLock to ON

▲ 1: Triggered when the speed instruction below Pn165 parameters

number	name	value range	the default value	unit	apply
Pn165	The clamp level zero speed	0~200	6	r/min	S

▲

When Pn164 is set to 1, and the speed instruction below this parameter value, the lock on the motor shaft. Example: this parameter is set to 10 r/min, if the analog speed instruction - 10 r/min ~ 10 r/min, within the scope of the deceleration clamp, in order to prevent the analog speed instruction near the zero drift, lead to the motor shaft instability.

number	name	value range	the default value	unit	apply
Pn166	Zero speed clamp deceleration time	5~10000	50	ms	S

▲ When zero velocity clamp when triggered, immediately according to deceleration time to slow down to zero, and then to lock.

number	name	value range	the default value	unit	apply
Pn167	internal position controller gain	5~2000	100	%	All

number	name	value range	the default value	unit	apply
--------	------	-------------	-------------------	------	-------

Pn168	Speed reference source	0~1	0		S
-------	------------------------	-----	---	--	---

▲ In speed control mode, the optional speed reference source:

Pn168=0: External simulation speed instruction within + 2 ~ 8

Pn168=1: Speed within 1 ~ 8

number	name	value range	the default value	unit	apply
Pn169	Internal speed reference 1	-5000-5000	0	R/min	S
Pn170	Internal speed reference 2	-5000-5000	0	R/min	S
Pn171	Internal speed reference 3	-5000-5000	0	R/min	S
Pn172	Internal speed reference 4	-5000-5000	0	R/min	S
Pn173	Internal speed reference 5	-5000-5000	0	R/min	S
Pn174	Internal speed reference 6	-5000-5000	0	R/min	S
Pn175	Internal speed reference 7	-5000-5000	0	R/min	S
Pn176	Internal speed reference 8	-5000-5000	0	R/min	S

▲ When a drive control mode in speed control mode, the speed reference source by the input port of the SigIn SP1, SP2, SP3 decision:

SP3	SP2	SP1	Speed instruction
0	0	0	Internal speed 1 / external analog instruction (decided by Pn168)
0	0	1	Internal speed 2
0	1	0	Internal speed 3
0	1	1	Internal speed 4
1	0	0	Internal speed 5
1	0	1	Internal speed 6
1	1	0	Internal speed 7

1	1	1	Internal speed g
---	---	---	------------------

Note 1: 0 is OFF, 1 is ON.

Note 2: if the SigIn port is not specified SP3, SP2, SP1 function, is OFF by default

number	name	value range	the default value	unit	apply
Pn177	speed	0~5000	200	r/min	S
Pn178◆	speed up the time	5~ 10000	100	ms	S
Pn179◆	Deceleration time	5~ 10000	100	ms	S

▲ When commissioning at, can set the speed of the motor running and the deceleration time

4.3.4 Torque control parameters

number	name	value range	the default value	unit	apply
Pn186	Torque command deceleration mode	0~1	0		T

▲ 0: Do not use the deceleration torque instruction

▲ 1 Using linear deceleration torque instruction

number	name	value range	the default value	unit	apply
Pn187▲	Linear deceleration time constant torque instruction	1~30000	1	ms	T

▲ Time constant is defined as a torque command from zero has soared to the rated torque.

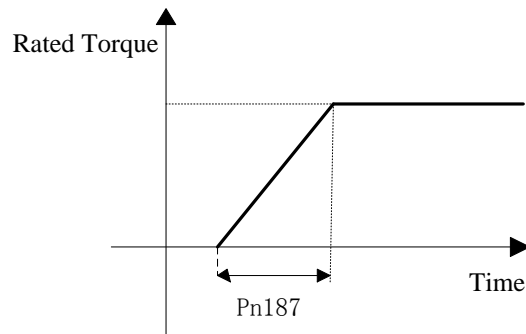

number	name	value range	the default value	unit	apply
Pn188▲	Analog torque instruction smooth filtering time	1~500	1	0.1ms	T

▲ The set value, the greater the input analog response speed is slow, is helpful to reduce the high frequency noise; Setup is smaller, the faster the speed of response, but will get big interference noise.

number	name	value range	the default value	unit	apply
Pn189	Analog gain torque instruction	1-300	30	%/V	T

▲ Analog torque command input and the ratio between the actual output torque. The range of input voltage - 10 ~ 10 v. The default input voltage of 10 v, motor at 3 times the rated torque, namely = $KX = 30x$, Y $K = 30$.

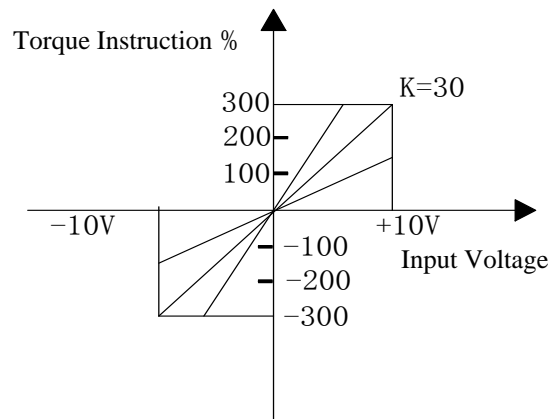

number	name	value range	the default value	unit	apply
Pn190	Analog torque instruction offset adjustment	-1500~1500	0	mv	T

▲ Adjust the way reference "simulation speed deviation adjustment directive"

	name	value	the	unit	apply
--	------	-------	-----	------	-------

number		range	default value		
Pn191	Simulation of torque command direction	0-1	0		T

▲ 0 Positive voltage forward (CCW), negative voltage inversion (the cw)

▲ 1 Turn negative voltage is (CCW), positive voltage inversion (the cw)

number	name	value range	the default value	unit	apply
Pn192	Q shaft torque regulator proportional gain is 1	5~ 2000	100	%	All
Pn193	Q shaft torque regulator integral time constant of 1	5~ 2000	100	%	All
Pn194	Q shaft torque regulator proportional gain is 12	5~ 2000	100	%	All
Pn195	Q shaft torque regulator integral time constant of 2	5~ 2000	100	%	All

▲ Increase the proportional gain, can make the Q axis current response speed.

▲ Reduce the integral time constant, can reduce the Q axis current control error

number	name	value range	the default value	unit	apply
Pn196	Torque Q axis filter time constant of 1	1-500	1	0.1ms	All
Pn197	Torque Q axis filter time constant of 2	1~500	1	0.1ms	All

▲ Inhibits mechanical vibration, the larger the set values, the better the results, will

cause slow response and may cause oscillation; Set the value is smaller, the faster the response, but the mechanical conditions.

number	name	value range	the default value	unit	apply
Pn198	Torque control speed limit	0~4500	2500	r/min	T



When the torque control, motor speed limit in this parameter range. There was a phenomenon of speeding can prevent the light load. Speeding, speed control to reduce the actual torque intervention, but the actual speed will be slightly error.

number	name	value range	the default value	unit	apply
Pn199	Source of limited torque control speed choice	0~2	0		T

▲ Pn199=0 Restricted by Pn198 parameters

Pn199=1 Restricted by internal speed instruction 1 ~ 8

Pn199=2: If Pn204 = 1, i.e., all instructions from the internal torque, torque, speed can be restricted by analog voltage speed command

▲ All the above speed limit both positive and negative, multiple speed limit, restricted to the minimum speed.

▲ If this parameter is set to 1, restricted by internal speed instruction, by sp1, sp2, sp3 limited decision speed value:

SP3	SP2	SP1	Speed instruction
0	0	0	Internal speed 1
0	0	1	Internal speed 2
0	1	0	Internal speed 3
0	1	1	Internal speed 4
1	0	0	Internal speed 5
1	0	1	Internal speed 6
1	1	0	Internal speed 7
1	1	1	Internal speed 8

1 0 means OFF, 1 is ON.

▲ Even if the setting values than the system allows the highest speed, the actual speed can limit under the highest speed.

number	name	value range	the default value	unit	apply
Pn200	The internal torque 1	-300~300	0	%	T

Pn201	The internal torque 2	-300~300	0	%	T
Pn202	The internal torque 3	-300~300	0	%	T
Pn203	The internal torque 4	-300~300	0	%	T

▲ Select the internal torque control mode, use input port of the SigIn TR1 TR2 can choose 4 kinds of torque command:

TR2	TR1	Torque command
0	0	The external torque 1 or internal analog torque instruction (decided by Pn204)
0	1	The external torque 2
1	0	The external torque 3
1	1	The external torque 4

NOTE:1 0 means OFF, 1 is ON.

Note 2: if the SigIn port doesn't specify TR2, TR1 functions, is OFF by default.

number	name	value range	the default value	unit	apply
Pn204	Torque command source	0~1	0		T

0: external analog torque command

1: internal torque 1

number	name	value range	the default value	unit	apply
Pn205	D shaft torque regulator proportional gain	5~2000	100	%	All
Pn206	D shaft torque regulator integral time constant	5~2000	100	%	All

▲ Space vector modulation, D shaft torque regulator proportional gain and integral time constant.

number	name	value range	the default value	unit	apply
Pn207	Speed feedback adjustment coefficient	1~3000	100		T

▲ When the torque control, the motor speed in a limited speed range, interventional speed feedback, to reduce the actual torque, so that the speed to limit within the scope of regression. Parameter Settings is smaller, the greater the amount of feedback, the faster the adjustment, the smaller amount of speeding, but is too small will fuel motor shaking; Parameter is set too large, adjust the slower, may have been speed, less than the speed limit. Actual speed will be slightly higher than the limit speed value.

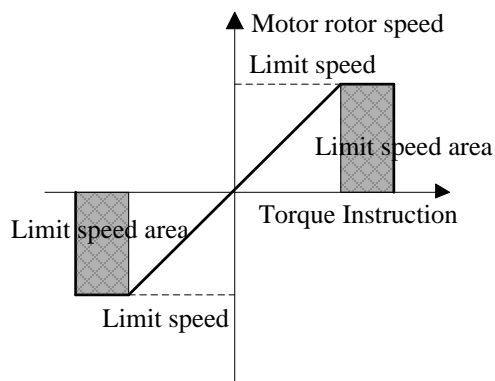

number	name	value range	the default value	unit	apply
Pn208	track torqueinstruction judgment error range 1	0~300	5	%	T
Pn209	track torqueinstruction judgment error range 2	0~300	2	%	T

▲ To make SigOut effective TCMDreach signal output port, must meet the following conditions:

Condition 1: PC set torque instruction must be

within the error range of 1. Example: input torque command 80%, Pn208 set to 5%, internal drive of input torque instruction in deceleration operation, when calculating the output torque of the instructions within the scope of 75% ~ 85%, condition 1 is satisfied.

Condition 2: detect the actual motor torque and the difference between the input torque of the instructions in the judgment error range within 2.

4.3.5 Extension control parameters

4.4 Port functions,

4.4.1 SigIn Sign port function explanation

number	symbol	function	Functional specifications
0	NULL	No function specified	Drive the input status does not produce any action.
1	Son	servo enable	<p>OFF The driver is not enabled, the motor without power</p> <p>ON Drive enabled, the motor power</p> <p>Note: Pn003 parameters or Son state decision.</p>
2	AlarmReset	The alarm reset	Alarm, and when the alarm can be clear, the input signal (OFF to ON), the delay to clear the alarm.
3	CCWL	Forward driving ban	<p>OFF: Motor forward is prohibited</p> <p>ON Allow the motor forward</p> <p>Note 1: if you want to use forward driving ban, first set Pn006 parameters, enabled, and designated to a specific to the input port. By default, do not use this feature.</p> <p>Note 2: the normal operation of the motor, CCWL must in a normally closed contact state (ON)</p> <p>Note 3: the origin, this function is invalid.</p>
4	CWL	Reverse driving ban	<p>OFF: Prohibit motor reversal</p> <p>ON Allow the motor reversal</p>
5	TCCW	External forward	OFF: CCW direction torque Pn010 parameters without limit

		torque limit	<p>ON: The CCW Direction torque Pn010 parameters restrictions</p> <p>Note: whether TCCW efficient or effective, CCW direction torque is also restricted by Pn008 parameters.</p>																																				
6	TCW	Around outside the torque limit	<p>OFF: The CW direction torque Pn011 parameters without limit</p> <p>ON: The CW direction torque Pn011 parameter restrictions</p> <p>Note: whether TCW efficient or effective, the CW direction torque is also restricted by Pn009 parameters.</p>																																				
7	EMG	Emergency stop	<p>OFF: Ban drive motor drive, to cut off the motor current</p> <p>ON: Allow normal drive motor drive</p>																																				
8	Zero Lock	Zero speed clamp	<p>Speed control:</p> <p>OFF: Don't lock the motor shaft</p> <p>ON : Lock the motor shaft</p>																																				
9	SP1	Internal speed command option 1	When a drive control mode in speed control mode, the speed reference source by SigIn SP1, SP2, SP3 decision:																																				
10	SP2	Internal speed command option 2	<table border="1"> <thead> <tr> <th>SP3</th> <th>SP2</th> <th>SP1</th> <th>Speed instruction</th> </tr> </thead> <tbody> <tr> <td>0</td> <td>0</td> <td>0</td> <td>internal speed 1 / External analog External analog</td> </tr> <tr> <td>0</td> <td>0</td> <td>1</td> <td>internal speed 2</td> </tr> <tr> <td>0</td> <td>1</td> <td>0</td> <td>internal speed 3</td> </tr> <tr> <td>0</td> <td>1</td> <td>1</td> <td>internal speed 4</td> </tr> <tr> <td>1</td> <td>0</td> <td>0</td> <td>internal speed 5</td> </tr> <tr> <td>1</td> <td>0</td> <td>1</td> <td>internal speed 6</td> </tr> <tr> <td>1</td> <td>1</td> <td>0</td> <td>internal speed 7</td> </tr> <tr> <td>1</td> <td>1</td> <td>1</td> <td>internal speed 8</td> </tr> </tbody> </table> <p>Note:0 means OFF, 1means ON.</p> <p>Note 2: if the SigIn port is not specified SP3, SP2,</p>	SP3	SP2	SP1	Speed instruction	0	0	0	internal speed 1 / External analog External analog	0	0	1	internal speed 2	0	1	0	internal speed 3	0	1	1	internal speed 4	1	0	0	internal speed 5	1	0	1	internal speed 6	1	1	0	internal speed 7	1	1	1	internal speed 8
SP3	SP2	SP1		Speed instruction																																			
0	0	0		internal speed 1 / External analog External analog																																			
0	0	1	internal speed 2																																				
0	1	0	internal speed 3																																				
0	1	1	internal speed 4																																				
1	0	0	internal speed 5																																				
1	0	1	internal speed 6																																				
1	1	0	internal speed 7																																				
1	1	1	internal speed 8																																				
11	SP3	3 nternal speed command option 1																																					

			SP1 function, is OFF by default.																
12	TR1	The internal torque command option 1	Select the internal torque control mode, the use of TR1, TR2 combination, can choose 4 kinds of torque command.																
13	TR2	The internal torque command																	
			<table border="1"> <thead> <tr> <th>TR2</th> <th>TR1</th> <th>Torque command</th> </tr> </thead> <tbody> <tr> <td>0</td> <td>0</td> <td>The external torque 1 / internal analog torque command</td> </tr> <tr> <td>0</td> <td>1</td> <td>The internal torque 2</td> </tr> <tr> <td>1</td> <td>0</td> <td>The internal torque 3</td> </tr> <tr> <td>1</td> <td>1</td> <td>The internal torque 4</td> </tr> </tbody> </table> <p>Note:0 means OFF,1means ON. Note 2: if the SigIn port doesn't specify TR2, TR1 functions, is OFF by default.</p>	TR2	TR1	Torque command	0	0	The external torque 1 / internal analog torque command	0	1	The internal torque 2	1	0	The internal torque 3	1	1	The internal torque 4	
TR2	TR1	Torque command																	
0	0	The external torque 1 / internal analog torque command																	
0	1	The internal torque 2																	
1	0	The internal torque 3																	
1	1	The internal torque 4																	
14	Cmode	Control mode switch	Parameter Pn002 for 3, 4, 5, control mode can be switched.																
15	Cgain	Gain switch	When the parameter Pn045 is 2, through Cgain switch gain combination: OFF The first gain ON: The second gain																
16	Gn1	Electronic gear molecular option 1	By Gn1, Gn2 combination, electronic gear molecules 1 ~ 4																
17	Gn2	Electronic gear molecular option 2																	
				<table border="1"> <thead> <tr> <th>Gn2</th> <th>Gn1</th> <th>N Electronic gear than N</th> </tr> </thead> <tbody> <tr> <td>OFF</td> <td>OFF</td> <td>the 1 molecular</td> </tr> <tr> <td>OFF</td> <td>ON</td> <td>the 2 molecular</td> </tr> <tr> <td>ON</td> <td>OFF</td> <td>the 3 molecular</td> </tr> <tr> <td>ON</td> <td>ON</td> <td>the 4 molecular</td> </tr> </tbody> </table>	Gn2	Gn1	N Electronic gear than N	OFF	OFF	the 1 molecular	OFF	ON	the 2 molecular	ON	OFF	the 3 molecular	ON	ON	the 4 molecular
Gn2	Gn1	N Electronic gear than N																	
OFF	OFF	the 1 molecular																	
OFF	ON	the 2 molecular																	
ON	OFF	the 3 molecular																	
ON	ON	the 4 molecular																	
18	CINV	Instructions in reverse	The speed or torque control mode, take the speed or torque of the instruction. OFF: The normal order ON: Instructions in reverse																
19	Pclear		Clear position deviation value of the counter, clear way by Pn108																

		Position deviation to clear	parameters: <table border="1" style="margin-left: 20px;"> <tr> <td>Pn108</td> <td>way</td> </tr> <tr> <td>0</td> <td>During the Pclear level ON</td> </tr> <tr> <td>1</td> <td>Pclear rise along time (from OFF to ON)</td> </tr> </table>	Pn108	way	0	During the Pclear level ON	1	Pclear rise along time (from OFF to ON)
Pn108	way								
0	During the Pclear level ON								
1	Pclear rise along time (from OFF to ON)								
20	INH	Pulse input is prohibited	OFF: Pulse allows input instructions ON : Input instruction pulse have been banned, ignored						
21	PC	Proportional control	OFF: Speed loop PI control ON : Speed loop P control						
22	GOH	The	See the appendix F						
23	REF	The origin return reference point							
24	Pos1	Pos1 internal location choice	See the appendix G						
25	Pos2	Pos2 internal location choice							
26	ptrigger	Trigger internal position command							
27	pstop	Suspend internal position command							

4.4.2 SigOut SigOut port function explanation

number	symbol	function	Functional specifications
0	null	No function specified	
1	Alarm	Alarm detection	OFF: alarm ON: no alarm

2	Ready	servo is ready	OFF: There are alarm or malfunction ON: No alarm and fault
3	Emg	Emergency stop checked out	OFF Not in a state of emergency stop ON : In a state of emergency stop
4	Preach	Positioning to complete	Position control mode OFF:Pn104 position deviation is greater than the parameter set value ON: The value of position deviation less than or equal to Pn104 parameters setting
5	Sreach	Speed to reach	OFF: Speed is less than Pn021 set value ON: Speed is greater than or equal to Pn021 set value
6	Treach	reach the predetermined torque	OFF: Torque is less than Pn024 set value ON: The value of torque is greater than or equal to Pn024 set
7	Zero Speed	zero speed	OFF: Faster than Pn027 set value ON: Speed is less than or equal to Pn027 set value
8	Run	Servo motor current	OFF: The motor has no electricity ON: motor current
9	BRK	Electromagnetic brake	OFF: Electromagnetic brake ON : Electromagnetic brake release
10	HOME	The origin return to complete	See the appendix F
11	Pnear	Located close to	in a position control OFF:Pn106 position deviation is greater than the parameter

			<p>set value</p> <p>ON: The value of position deviation less than or equal to Pn106 parameters setting</p>
12	TRQL	The Torque Limit	<p>OFF: The motor torque is not limited</p> <p>ON: The motor torque is limited</p> <p>When the torque command reaches Pn008 Pn009, Pn010, the parameter value, the smallest Pn011 TRQL to ON.</p>
13	SPL	The Speed Limit	<p>When the torque control</p> <p>OFF: Motor speed wasn't up to the limiting value</p> <p>ON: Motor speed has reached the limit</p> <p>Look Pn198 Pn199 instructions</p>
14	TCMDreach	Look Pn198 Pn199 instructions	<p>In torque control:</p> <p>OFF Motor torque did not reach the upper machine set torque instruction value</p> <p>ON The setting of motor torque reaches the upper machine set torque instruction value</p> <p>See Pn208, Pn209 instructions.</p>

Chapter 5 monitoring parameters and operation

5.1 Monitor panel operation

As shown in the third chapter "monitoring mode operation"

5.2 Monitor the parameter list

number	instruction
dn-00	Monitor display options (the default for motor speed), and by setting the Pn079 parameter, make the dn - 00 show different monitoring status.
dn-01	Speed instruction (r/min)
dn-02	The average torque (%)
dn-03	Position deviation value (9999 ~ 9999) (unit: a)
dn-04	The ac power voltage (V)
dn-05	The maximum instantaneous torque (%)
dn-06	Input pulse frequency (in KHZ)
dn-07	Heat sink temperature (°C)
dn-08	The current motor speed (r/min)
dn-09	Effective input command pulse accumulative total value low (9999 ~ 9999) (unit: a)
dn-10	Effective input command pulse accumulative total value high (5000 ~ 5000) (unit: m) (pulse accumulative total value high more than + 5000, the high position 0, low today, to count)
dn-11	Effective feedback position control, the encoder pulse accumulative total value is low (9999 ~ 9999) (unit: a)
dn-12	Effective feedback position control, the encoder pulse accumulative total value high (5000 ~ 5000) (unit: m) (feedback pulse accumulative total value more than + 5000 high, high position 0, low today, to count)
dn-13	Regenerative braking load factor
dn-14	Signal input port state, from left to right in turn is SigIn1 ~ SigIn4 (1: high level; 0: low level)
dn-15	Output port status signal, from left to right in turn is SigOut1 ~ SigOut4 (1: high level; 0: low level)
dn-16	Analog torque command voltage (V)
dn-17	Simulation speed reference voltage (V)
dn-18	Output function status register

dn-19	After power on the servo, motor feedback pulse accumulative total value low (9999 ~ 9999) (unit: a)
dn-20	Electric servo, motor feedback pulse accumulative total value high (5000 ~ 5000) (unit: m) (feedback pulse accumulative total value more than + 5000 high, high position 0, low today, to count)
dn-21	The drive software version
dn-22	Encoder UVW signals from left to right in order for the sale of state level (1: high level; 0: low level)
dn-23	Rotor absolute position

Note: Dn - 18 output function status register SigOut port state of logic, namely each Bit position shown in the table below:

Bit	Bit7	Bit6	Bit5	Bit4	Bit3	Bit2	Bit1	Bit0
function	Run	Zero Speed	Treach	Sreach	Preach	Emg	Ready	Alarm
Bit	Bit15	Bit14	Bit13	Bit12	Bit11	Bit10	Bit9	Bit8
function	-	-	-	SPL	TRQL	Pnear	HOME	BRK

Function for Bit is 0, said ON state, 1 is the OFF state.

Chapter 6 alarm and processing

6.1 Alarm clearance operations

As shown in the third chapter of the auxiliary model operation "police clearance operation"

6.2 Alarm content and countermeasure

Alarm display	Clear way	Abnormal alarm instructions	Elimination method
AL-01	power on	The memory chip memory contents are	To initialize the parameters, and observation. Internal

		destroyed or damaged	chip is damaged, replace the servo amplifier.
AL-02	reset	In the case of lack of low-pressure warning, dc bus voltage below Pn083 alarm (200 v).	<p>1 The external power supply voltage is measured with a voltmeter is in accordance with the specifications. If conform to the specifications, can use Fn009 auxiliary mode, busbar voltage correction.</p> <p>2 Through the display panel, into monitor mode, observations show that whether the voltage is consistent with an external voltage, if the difference is too big, the internal components damaged, replace the servo amplifier.</p> <p>3 Motor start too fast, large load, which leads to the internal bus voltage is lower. If it is single phase power supply access, please use three-phase power supply connection.</p>
AL-03	power on	Internal dc bus voltage is higher than Pn084 (365 v).	<p>1 The external power supply voltage is measured with a voltmeter is in accordance with the specifications. If conform to the specifications, can use Fn009 auxiliary mode, busbar voltage correction.</p> <p>2 Through the display panel, into monitor mode, observations show that whether the voltage is consistent with an external</p>

			<p>voltage, if the difference is too big, the internal components damaged, replace the servo amplifier.</p> <p>3 In a reasonable range, appropriate reduction small load inertia or prolonged deceleration, or need additional braking resistor.</p>
AL-04	power on	Intelligent power module directly produce the report to the alarm	<p>1 Check the motor line U, V, W and encoder line is normal.</p> <p>2 Turn the power off half an hour, electricity again, if the alarm is still there, may be internal power module is damaged, please replace the servo amplifier.</p> <p>3: Speed loop and current loop pid parameter Settings.</p>
AL-05	reset	overload 1	<p>Pn014 parameters set period of time for greater than Pn012 overload capacity parameters or Pn013 set by multiples of the current.</p> <p>1 Check the motor line U, V, W and encoder line is normal.</p> <p>2: Motor high frequency, acceleration and deceleration delay when the director of the deceleration time, reduce the load inertia, or in more powerful capacity</p>

			of servo motor.
AL-06	power on	overload 2	<p>Pn015 parameter set period of time, 3 times greater than the rated load. Eliminate overload method reference 1.</p> <p>Note: some motor can only bear the 2.5 or 2 times of the rated load, are not as calculated as 3 times.</p>
AL-07	reset	Motor speed is too high	<ol style="list-style-type: none"> 1 Check the motor line U, V, W and encoder line is normal. 2 Reduce the pulse frequency of input instructions, or adjust the electronic gear ratio. 3 Improper speed loop pid parameter adjustment, readjust.
AL-08	reset	Servo amplifier heat sink overheating, actual temperature has more than 70 °C	<ol style="list-style-type: none"> 1 Repeat overload will cause the drive overheating, please change the motor operation mode. For prolonging the life of the server, and should be used under the environment temperature of 55 °C, the recommended temperature does not exceed 40 °C. 2: Brake average power overload.
AL-09	power	The encoder abnormal	<ol style="list-style-type: none"> 1 Check whether the motor encoder wiring is connected to the drive. 2 Check

			<p>whether the motor encoder interface virtual welding, short circuit, or fall off, the encoder the power cord is normal connection.</p> <p>3: Check the encoder voltage (5 v + / - 5%). (encoder line is long, need to pay special attention to)</p>
AL-10	reset	Actually receives the pulse frequency is too high, more than 600 KPPS	<p>1 Electronic gear ratio (A/B) Settings. To adjust the ratio of A/B.</p> <p>2: Reduce the pulse frequency of the input command</p>
AL-11	reset	Deviation number of Location pulse more than setting number	<p>1 Check the motor line U, V, W and encoder line is normal.</p> <p>Position command smoothing time constant set is too large.</p> <p>3: Increase the position loop gain, to speed up the response speed of the machine.</p> <p>4 Using the monitor model, check to see if the motor output torque limits.</p>
AL-12	reset	Current sampling circuit may be damaged	<p>1 The instantaneous electric current too big, is beyond the range of detection.</p> <p>2: Check the motor line (U, V, W) whether loose fall off.</p> <p>3: Sampling circuit is damaged, replace the servo amplifier.</p>
AL-13	power on	The CPU internal fault	<p>1: The external interference is too large, reduce the interference.</p> <p>2: The</p>

			CPU chip is damaged, replace the servo amplifier.
AL-14	Emergency stop	Emergency stop signal is effective	See if port, setting of emergency stop function, signal contact is in a normally closed state (ON)
AL-15	Abnormal driving ban	Ccwl or.cwl to OFF state	<p>1: Check CCWL,.cwl wiring, the signal contact is in a normally closed state (ON).</p> <p>2 If do not use the driving ban function, can set pn006 parameters, to block it.</p>
AL-16	Brake average power overload	The input voltage is too high or braking load rate above 85%	<p>1 Using the monitoring mode to see if the input voltage is beyond the normal range</p> <p>2 Reduce the start-stop frequency</p> <p>3 External more powerful regenerative braking resistor (remove internal brake resistance, not parallel)</p> <p>4 Increase the deceleration time</p> <p>5 Renewable power resistance value and the resistance value is set correctly</p> <p>6 Change a more powerful motor and drive</p>
AL-17	Abnormal encoder signal frequency output	Set the encoder output of frequency division than not.	Resetting Pn016, Pn017 parameter values, must satisfy the DA/DB > = 1.

	Settings		
AL-18	Improper motor code sets	The current drive model does not support setting of motor model	Reference drive and motor type adapter table, resetting Pn001.

Chapter 7 Modbus communication function

7.1 Modbus communication profile

This drive is RS - 232 and RS - 485 communication interface,

the user can choose a kind of communication interface and the driver. Communication method adopts the Modbus transfer agreement, can use the following two communication modes: ASCII (American Standard Code for information interchange) mode and the RTU (Remote Terminal Unit) model. Before communication, you must first set up good communication related parameters (Pn064 ~ Pn071).

7.1.2 Coding meaning

ASCII mode:

Each 8-bit data consists of two ASCII characters. For example, a 78 - byte data 1 h (hexadecimal notation), expressed in ASCII, contains the '7' ASCII (37 h) and "8" ASCII (38 h).

The Numbers 0 to 9 and letters A through F ASCII, the following table:

Character symbols	'0'	'1'	'2'	'3'	'4'	'5'	'6'	'7'
Corresponding to the ASCII	30H	31H	32H	33H	34H	35H	36H	37H
Character symbols	'8'	'9'	'A'	'B'	'C'	'D'	'E'	'F'
Corresponding	38H	39H	41H	42H	43H	44H	45H	46H

to the ASCII								
--------------	--	--	--	--	--	--	--	--

RTU mode:

Each 4 - bit 8-bit data by two hexadecimal data, namely the general number of hexadecimal. For example, decimal in 1 120 - byte RTU data representation for 78 H.

7.1.3 The data structure

10 bit character mode (for 7 bit data)

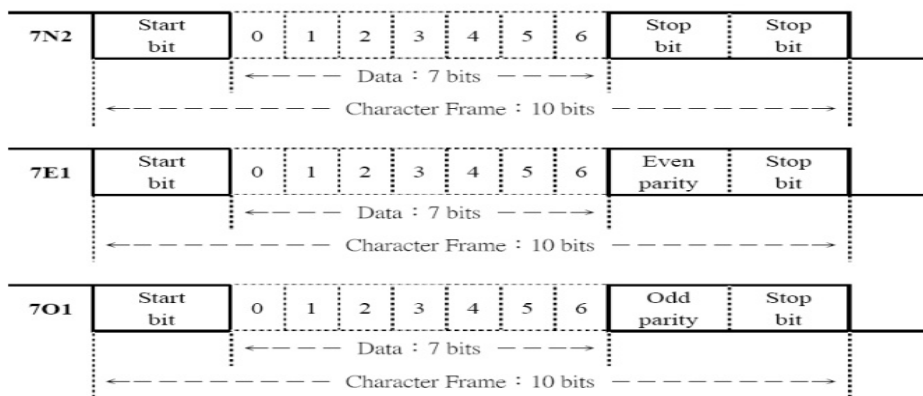

11 bit character mode (for 8 bit data)

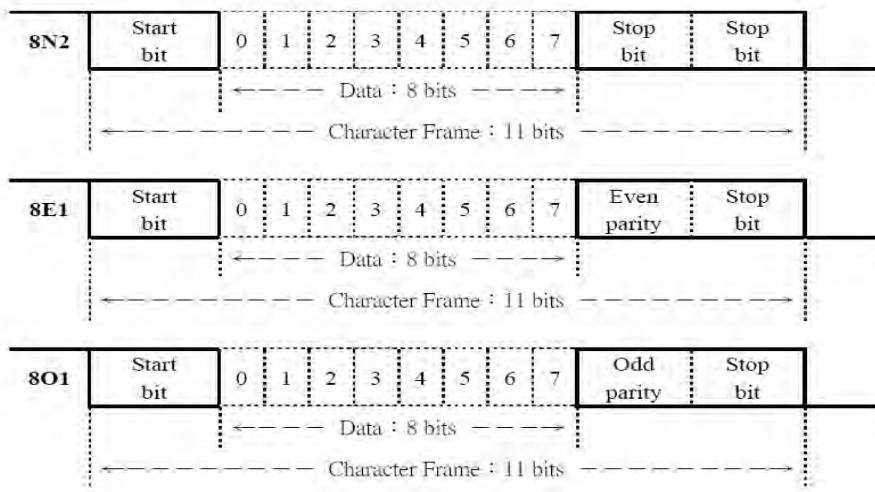

7.2 Communication protocol structure

ASCII mode

name	meaning	instruction
Start	Communication began	The starting character ':' (ASCII: 3 ah)
Address	The communication address	Address, that is, drive site number. For example: a drive site # 32, hexadecimal for 20 h, Address = '2', '0' or '2' = 32 h, '0' = 30 h
CMD	order	1 byte contains two ASCII. Commonly used commands: 3 h (read registers), 6 h ((reading a single register), 8 h (diagnostic function), 10 h (write multiple register)
DATA(n-1)	The data content	N = 2 N word bytes = 4 N ASCII (N < = 8)
.....		
DATA(0)		
LRC	Check code	1 byte contains two ASCII
End 1	The end of the code 1	0 dh, i.e., CR
End 0	The end of the code 0	0 ah, that is, LF

RTU mode

name	meaning	instruction
Start	Communication began	The rest time to at least 3.5 bytes transmission time
Address	The communication address	

		Address, that is, drive site number. For example: a drive site # 32, hexadecimal for 20 h, Address = 20h
CMD	command	1 byte. Commonly used commands: 3 h (read registers), 6 h ((reading a single register), 8 h (diagnostic function), 10 h (write multiple register)
DATA(n-1)	data content	Word N= 2 N bytes (N <= 9)
.....		
DATA(0)		
CRC	Check code	1 byte
End 1	The end	The rest time to at least 3.5 bytes transmission time

7.3 Commonly used command code

7.3.1 Reading a multiple register

03H Reading a multiple register

Instructions: read the N word, N values for 1 ~ 8 scope

Example: from the site of 01 h drive read starting address 0013 h 2 words.

1. ASCII mode

PC ->drive

start	‘.’
Address	‘0’

Response -> PC (OK)

start	‘.’
Address	‘0’

Response -> PC (Error)

start	‘.’
Address	‘0’

		'1'
cmd		'0'
		'3'
Data source address	high bit	'0'
		'0'
	low bit	'1'
		'3'
Read the register number		'0'
		'0'
		'0'
		'2'
LRC		'E'
		'7'
END1(CR)		0DH
END0(LF)		0AH

		'1'
cmd		'0'
		'3'
Data bytes		'0'
		'4'
Address 0013 h content	high bit	'0'
		'0'
	low bit	'3'
		'2'
Address 0014 h content	high bit	'0'
		'0'
	low bit	'0'
		'A'
LRC		'B'
		'C'
END1(CR)		0DH
END0(LF)		0AH

		'1'
cmd		'8'
		'3'
Abnormal code		'0'
		'2'
LRC		'7'
		'A'
END1(CR)		0DH
END0(LF)		0AH

2. RTU Mode

PC -> drive

Address		01H
CMD		03H
Data source address	high bit	00H
	low bit	13H

Response -> PC (OK)

Address		01H
CMD		03H
Data bytes		04H
The	high bit	00H
	low bit	

Response -> PC (Error)

Address		01H
CMD		83H
Abnormal code		02H
CRC low bit		00H

Read the register number	00H
	02H
CRC low bit	35H
CRC high bit	CEH

content of the 0013 h address	low bit	32H
The content of the 0014 h address	high bit	00H
	low bit	0AH
CRC bit	low	DBH
CRC bit	high	FBH

CRC high bit	F1H
--------------	-----

7.3.2 Write a single register

06H Write a single register

Description: write a word to the register.

For example: drive station number of 01, write data initial address is 0013 h, write data, 100 (64 h).

1. ASCII MODE

PC -> drive

Response -> PC (OK)

Response -> PC (Error)

start	‘:’	
Address	‘0’	
	‘1’	
cmd	‘0’	
	‘6’	
Data source address	high bit	‘0’
		‘0’
	low	‘1’
		‘3’

start	‘:’	
Address	‘0’	
	‘1’	
cmd	‘0’	
	‘6’	
Data source address	high bit	‘0’
		‘0’
	low	‘1’
		‘3’

start	‘:’
Address	‘0’
	‘1’
cmd	‘8’
	‘6’
Abnormal code	‘0’
	‘3’
LRC	‘7’
	‘6’

	bit	
The data content (word format)		'0'
		'0'
		'6'
		'4'
LRC		'8'
		'2'
END1(CR)		0DH
END0(LF)		0AH

	bit	
The data content (word format)		'0'
		'0'
		'6'
		'4'
LRC		'8'
		'2'
END1(CR)		0DH
END0(LF)		0AH

END1(CR)	0DH
END0(LF)	0AH

2. RTU MODE

PC -> drive

Address		01H
CMD		06H
Data source address	high bit	00H
	low bit	13H
The data content (word format)		00H
		64H
CRC bit	low	79H
CRC bit	high	E4H

Response -> PC
(OK)

Address		01H
CMD		06H
Data source address	high bit	00H
	low bit	13H
The data content (word format)	F4H	00H
	48H	64H
CRC bit	low bit	79H
CRC bit	high bit	E4H

Response -> PC
(Error)

Address		01H
CMD		86H
Abnormal code		03H
CRC bit	low bit	02H
CRC bit	high bit	61H

7.3.3 diagnosis

08H: 诊断功能 Diagnostic function

说明: 使用子功能码 0000H, 检查在 Master 和 Slaver 之间的传输信号。数据内容可为任意数。Note: use 0000 h subfunction code, check the signal transmission between the Master and Slaver. The data content can be any number.

例如: 对站点为 01H 的驱动器使用诊断功能。For example: the site of 01 h drive using diagnostic function

1. ASCII 模式

上位机->驱动器 PC -> drive		回应->上位机 Response -> PC (OK)		回应->上位机 Response -> PC (Error)	
start		start		start	
Address		Address		Address	
cmd		cmd		cmd	
子功能码 Subroutine code	高位 high bit	子功能码 Subroutine code	高位 high bit	异常码 Abnormal code	高位 high bit
	低位 low bit		低位 low bit		低位 low bit
数据内容 (word 格式) The data content (word format)		数据内容 (word 格式) The data content (word format)		END1(CR)	
				END0(LF)	
LRC		LRC			
END1(CR)		END1(CR)			
END0(LF)		END0(LF)			

2. RTU 模式 RTU mode

上位机->驱动器 PC ->
drive

Address		01H
CMD		08H
子功能码 Subroutine code	高位 high bit	00H
	低位 low bit	00H
数据内容 (word 格式) The data content (word format)	高位 high bit	86H
	低位 low bit	31H
CRC 低位 low bit		43H
CRC 高位 high bit		BFH

回应->上位机
Response -> PC
(OK)

Address		01H
CMD		08H
子功能码 Subroutine code	高位 high bit	00H
	低位 low bit	00H
数据内容 (word 格式) The data content (word format)	高位 high bit	86H
	低位 low bit	31H
CRC 低位 low bit		43H
CRC 高位 high bit		BFH

回应->上位机
Response -> PC
(Error)

Address		01H
CMD		88H
异常码 Abnormal code		03H
CRC 低位 low bit		06H
CRC 高位 high bit		01H

7.3.4 写多个寄存器 Write multiple register

10H: 写多个寄存器 Write multiple register

说明：将 N 个字写到连续寄存器中，N 最大为 8 (08H)。Note: write the N word to register in a row, the N maximum 8 h (08).

例如：将 100 (0064H)、300 (012CH) 写到局号为 01 伺服驱动器的起始地址 0013H 的连续两个寄存器中。For example: 100 (0064 h), 300 (012 ch) writes JuHao for 01 servo drives the starting address of 0013 h two consecutive registers.

1. ASCII 模式 ASCII MODE

上位机->驱动器
PC -> drive

start		‘:’
Address		‘0’
		‘1’
cmd		‘1’
		‘0’
数据起始地址 Data source address	高位 high bit	‘0’
	低位 low bit	‘0’
		‘1’
	‘3’	
写寄存器个数 Write the register number		‘0’
		‘0’
		‘0’
		‘2’
数据字节数 Data bytes		‘0’
		‘4’
写数据到 0013H Write data to the 0013 h	高位 high bit	‘0’
	低位 low bit	‘0’
		‘6’
	‘4’	

回应->上位机 Response
-> PC (OK)

start		‘:’	
Address		‘0’	
		‘1’	
cmd		‘1’	
		‘0’	
数据起始地址 Data source address	高位 high bit	‘0’	
	低位 low bit	‘0’	
		‘1’	
	‘3’		
写寄存器个数 Write the register number		高位 high bit	‘0’
		低位 low bit	‘0’
			‘0’
		‘2’	
LRC		‘4’	
		‘1’	
END1(CR)		0DH	
END0(LF)		0AH	

回应->上位机 Response
-> PC (Error)

start		‘:’
Address		‘0’
		‘1’
cmd		‘9’
		‘0’
异常码 Abnormal code		‘0’
		‘3’
LRC		‘6’
		‘C’
END1(CR)		0DH
END0(LF)		0AH

写数据到 0014H Write data to the 0014 h	高位 high bit	'0'
		'1'
	低位 low bit	'2'
		'C'
LRC		'4'
		'5'
END1(CR)		0DH
END0(LF)		0AH

2. RTU 模式

上位机->驱动器 PC->
drive

Address		01H
CMD		10H
数据起始地址 Data source address	高位 high bit	00H
	低位 low bit	13H
写寄存器个数 Write the register number	高位 high bit	00H
	低位 low bit	02H
数据字节数		04H

回应->上位机 Response
-> PC (OK)

Address		01H
CMD		10H
数据起始地址 Data source address	高位 high bit	00H
	低位 low bit	13H
写寄存器个数 Write the register number	高位 high bit	00H
	低位 low bit	02H

回应->上位机
Response -> PC
(Error)

Address		01H
CMD		90H
异常码 Abnormal code		03H
CRC 低位 low bit		0CH
CRC 高位 high bit		01H

Data bytes		
写数据到 0013H Write data to the 0013h	高位 high bit	00H
	低位 low bit	64H
写数据到 0014H Write data to the 0014h	高位 high bit	01H
	低位 low bit	2CH
CRC 低位 low bit		F3H

CRC 低位 low bit	B0H
CRC 高位 high bit	0DH

位有符号整数。A signed integer.

注 2: 写单个寄存器, 上位机需用 5.5ms 左右时间, 以等待驱动器完成内部数据存储器的烧写; 同理, 写 N 个寄存器 (N<=8), 则上位机需要 5.5ms*N 等待时间, 才能再发送写命令。 Note 2: write a single register, PC must be about 5.5 ms, waiting for the driver to complete the internal data storage of burning; By the same token, the register write N (N <= 8), the upper machine needs 5.5 ms * N waiting time, to send the write command.

注 3: 读取 Dn-13 参数时, 实际电压值=读取值/100。 Note 3: read the Dn - 13 parameters, the actual voltage value = value read / 100.

7.3.5 校验码计算 Check code to calculate

1. LRC 校验 LRC England check

ASCII 模式采用 LRC (Longitudinal Redundancy Check) 校验码。LRC 校验是计算 Address、CMD、起始数据地址及数据内容之总和, 将总和结果以 256 为单位, 取余数 (若总和结果为 150H, 则只取 50H) 后, 再计算其补码, 最后得到的结果为 LRC 校验码。ASCII mode using LRC England (Longitudinal Redundancy Check) Check code. LRC England calibration is to calculate the Address, CMD, initial data Address and the sum total of the data content will be combined results in 256, modulo (if the sum of the results for 150 h, then only take 50 h), to calculate its complement, the final results for LRC England check code.

例: 从站点 01 H 伺服驱动器的 0013 地址读取 2 个字 (word)。 Example: 01 H servo drive from site 0013 address read 2 word (word)

start		‘.’
Address		‘0’
		‘1’
cmd		‘0’
		‘3’
数据起始地址 Data source address	高位 high bit	‘0’
		‘0’
	低位 low bit	‘1’
		‘3’
读寄存器个数 Read the register number		‘0’
		‘0’
		‘0’
		‘2’
LRC		‘E’
		‘7’
END1(CR)		0DH
END0(LF)		0AH

从 Address 的数据加至最后一个数据: From the Address data add to the last data:

01 H + 03H + 00H + 13H + 00H + 02H = 19H, 因 19H 的补码为 E7H, 所以 LRC 为 ‘E’, ‘7’ 01 H + 3 H + 00 00 H + 13 H + H + 02 H = 19 H, for 19 H complement E7H, so LRC England as the 'E', '7'

2. CRC 校验 CRC check

RTU 模式采用 CRC (Cyclical Redundancy Check) 校验码。循环冗余校验 (CRC) 域为两个字节, 包含一个二进制 16 位值。附加在报文后面的 CRC 的值由发送设备计算。接收设备在接收报文时重新计算 CRC 的值, 并将计算结果于实际接收到的 CRC 值相比较。如果两个值不相等, 则为错误。RTU mode adopts CRC (Cyclical Redundancy Check) Check code. Cyclic redundancy check (CRC) domain into two bytes, containing a binary 16-bit value. Attached to the message behind the CRC value calculated by the transmitting device. When receiving device on the receiving message to recalculate the CRC value, and the calculated results compared to actually receives the CRC value. If the two values are not equal, is wrong.

CRC 的计算, 开始对一个 16 位寄存器预装全 1。然后将报文中的连续的 8 位子节对其进行后续的计算。只有字符中的 8 个数据位参与生成 CRC 的运算, 起始位, 停止位和校验位不参与 CRC 计算。CRC calculation, to a 16-bit registers with full 1. Then put the message in the continuous section 8 of the seats on the subsequent calculations. Only the characters of the eight data bits participate in the operation of generating CRC, start bit, stop bits and parity bit CRC calculation will not be involved.

生成 CRC 的过程为: To generate CRC process as follows:

1. The a 16-bit registers into hexadecimal FFFF. (1) all will be referred to as the CRC register.
2. The first 8 bytes of a message with a 16-bit CRC register low byte exclusive or, result in CRC register.
- 3.The CRC register moves to the right one to the LSB (direction), the MSB filling zero. Extraction and detection of LSB.
4. ((if the LSB of 0) : repeat step 3 (another shift).
(if the LSB to 1) : the CRC register exclusive or polynomial value 0 xa001 (1010, 0000, 0000, 0001).
5. Repeat steps 3 and 4 until complete displacement of 8 times. As after this action, will complete the full operation of eight bytes.
6. For the next byte of message repeat steps 2 to 5, this operation until all message being processed.
7. CRC CRC register the final content for CRC value.
8. When the CRC value is placed on a message, high and low byte must exchange.
Byte is sent first, and then the high byte

For example: from the site of 01 H drive reads two words (word), reading the starting address of 0200 H address. The last of the data from the Address to calculate the CRC register at the end of the content is 0704 H, is the instruction format as shown below, note that the front of the 04 H in H.

Address		01H
CMD		03H
Data source address	high bit	02H
	low bit	00H
Data length (in terms of word)		00H
		02H
CRC low bit		04H
CRC high bit		07H

CRC generation paradigm:

The following CRC value by C language. This function requires two parameters:

Unsigned char * data; // data source address, used to calculate the CRC value

Unsigned char length; // data length

This function returns the unsigned integer type of CRC value.

```

unsigned int crc_chk(unsigned char * data,unsigned char length)
{
    int i,j;
    unsigned int crc_reg=0xFFFF;
    While(length- -)
    {
        Crc_reg ^=*data++;
        for(j=0;j<8;j++)
        {
            If(crc_reg & 0x01)
            {
                crc_reg=( crc_reg >>1)^0xA001;
            }else
            {
                crc_reg=crc_reg >>1;
            }
        }
    }
    return crc_reg;
}

```

7.3.6 Abnormal code

In the process of communication, may create a communication error, common error event in the following table:

Communication error event	Servo driver approach
Read/write parameters, data address is not correct;	The request for processing, and abnormal return an error code
Write parameters, data number	The request for processing, and abnormal return an error code

more than the maximum or not within the scope of this parameter;	
数据传输错误或者校验码(LRC、CRC、奇偶检验)错误 Data transmission errors or check code (LRC England, CRC, parity check) error	数据被丢弃，不返回响应，上位机应将请求作为超时状态处理 Data is discarded, not returns the response, PC should be request as state handling overtime

驱动器发送错误异常码时，将命令功能码加上80H后一起传送给ModBus 主站系统。异常码如下表: Drive send error exception code, will command function code plus 80 h after send the ModBus master station system together. Abnormal code in the following table:

01 H	伺服驱动器不能识别请求的功能码 The function of the servo driver does not recognize the request code
02 H	请求给出的数据地址非法Data address illegal request
03 H	请求给出的数据在伺服驱动器中不允许（读写数据个数超过驱动器允许最大值或写数据值不在参数的取值范围内） Request the data given in the servo driver does not allow (read and write data number more than drive to allow maximum or write data value is beyond the scope of parameter values)
04 H	伺服驱动器已经在开始执行请求，但不能完成该请求。 Servo drives are beginning to execute the request, but can't complete the request.

7.4 伺服参数、状态信息通信地址 The servo parameters, the state information communication address

数据地址 Data address		含义 meaning	说明 instructions	操作 operation
十六进制 hexadecimal	十进制 The decimal system			
0000H~00EFH	0 ~ 239	参数设置区 Parameter setting area	对应 Pn000~Pn239 Corresponding Pn000 ~ Pn239	可读可写 Can read but write
0164H~016DH	356 ~ 365	报警记录区 Alarm recording area	在 Fn000 中可以查看，对应 Sn--0~Sn--9 In Fn000 can view, corresponding Sn - 0 to Sn - 9	只读 read-only
0170H~0185H	368 ~ 389	数据监控区 Data monitoring area	对应 Dn000~Dn021	只读

附录 The appendix

附录 A 增益切换 Appendix A gain switch

第一增益 The first gain		第二增益 The second gain	
参数 parameter	名称 name	参数 parameter	名称 name
Pn153	速度调节器比例增益 1 The speed regulator proportional gain 1	Pn155	速度调节器比例增益 2 The speed regulator proportional gain 2
Pn154	速度调节器积分时间常数 1 Speed regulator integral time constant of 1	Pn156	速度调节器积分时间常数 2 Speed regulator integral time constant of 2
Pn192	转矩 Q 轴调节器比例增益 1Q shaft torque regulator proportional gain is 1	Pn194	转矩 Q 轴调节器比例增益 2Q shaft torque regulator proportional gain is 2
Pn193	转矩 Q 轴调节器积分时间常数 1 Q shaft torque regulator integral time constant of 1	Pn195	转矩 Q 轴调节器积分时间常数 2 Q shaft torque regulator integral time constant of 2
Pn196	转矩 Q 轴滤波时间常数 1Torque Q axis filter time constant of 1	Pn197	转矩 Q 滤波时间常数 2Torque Q axis filter time constant of 2
Pn115	位置调节器增益 1 The position controller gain 1	Pn116	位置调节器增益 2 The position controller gain 2

注：增益切换时，必须处于合适的控制模式，设置参数 Pn046 的条件合适，才能满足增益切换条件，进行切换。 Note: gain switch, must be in the right control mode, the setting parameters Pn046 conditions are right, to meet gain switching conditions, to switch.

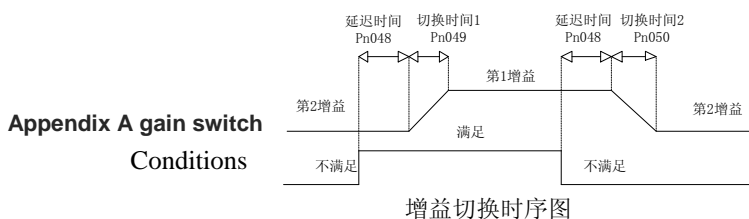

附录 B 控制模式切换 Appendix B control mode switch

B.1 位置/速度控制模式切换 Position/speed control mode switch

使用控制切换(cmode), 可通过输入控制端口SigIn接点进行位置控制模式和速度控制模式的切换。Using the control switch (cmode), can be controlled by input port SigIn contact for position control and speed control mode switch.

cmode和控制模式的关系如下所示。Cmode relationship with control mode is shown below.

Cmode	控制模式control mode
OFF	位置控制模式Position control mode
ON	速度控制模式Speed control mode

可以在零速度状态时进行控制模式的切换。但为了安全起见, 请在伺服电机停止时进行切换。从位置控制模式切换到速度控制模式时, 滞留脉冲将被清除。电机使能前, 请先确定要进入的控制模式 (cmode引脚的状态)。电机使能时, 切换方式有两种, 时序图如下所示: Can be in the state of zero speed control mode switch. But to be on the safe side, please switch with the servo motor stopped. From the position control mode switch to the speed control mode, the trapped pulse will be cleared. Before the machine can make, please make sure to enter the control mode (state) of cmode pin. Motor can make, there are two main ways to switch, sequence diagram as shown below:

▲Pn132=0:

只有零速度状态下, 切换信号发生改变, 模式切换才有效; 如果不在零速度状态下, 切换信号发生了改变, 随后信号进入零速度状态, 则不发生模式切换。Only the zero velocity condition, switching signal changes, the mode switch is valid; If not zero velocity state, the switching signal is changed, then enter into the state of zero speed signal, the mode switch does not occur.

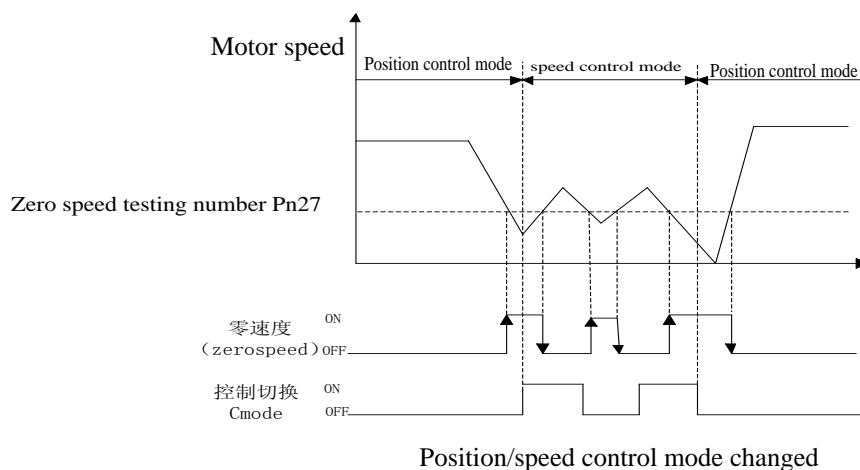

▲Pn132=1:

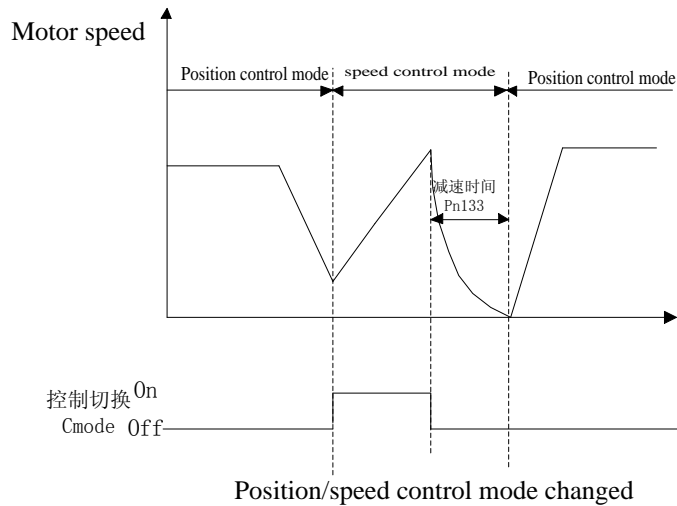

B.2 位置/转矩控制模式切换 Position/torque control mode switch

使用控制切换(cmode), 可通过输入控制端口SigIn接点进行位置控制模式和转矩控制模式的切换。cmode和控制模式的关系如下所示。Using the control switch (cmode), can be controlled by input port SigIn contact position control mode and the torque control mode switching. Cmode relationship with control mode is shown below.

Cmode	控制模式control mode
OFF	位置控制模式position control mode
ON	转矩控制模式Torque control mode

可以在零速度状态时进行控制模式的切换。但为了安全起见, 请在伺服电机停止时进行切换。从位置控制模式切换到转矩控制模式时, 滞留脉冲将被清除。电机使能时, 切换方式有两种, 时序图如下所示: Can be in the state of zero speed control mode switch. But to be on the safe side, please switch with the servo motor stopped. From the position control mode switch to the torque control mode, the trapped pulse will be cleared. Motor can make, there are two main ways to switch, sequence diagram as shown below:

▲Pn132=0:

只有零速度状态下, 切换信号发生改变, 模式切换才有效; 如果不在零速度状态下, 切换信号发生了改变, 随后信号进入零速度状态, 则不发生模式切换。Only the zero velocity condition, switching signal changes, the mode switch is valid; If not zero velocity state, the switching signal is changed, then enter into the state of zero speed signal, the mode switch does not occur.

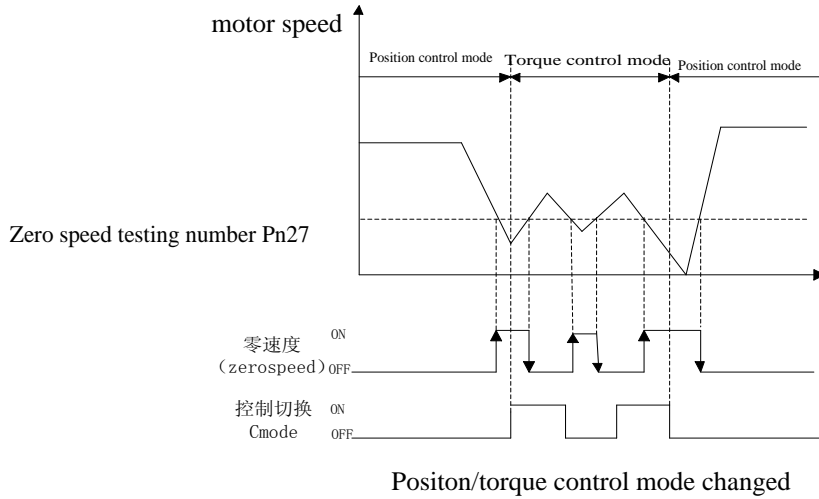

▲Pn132=1:

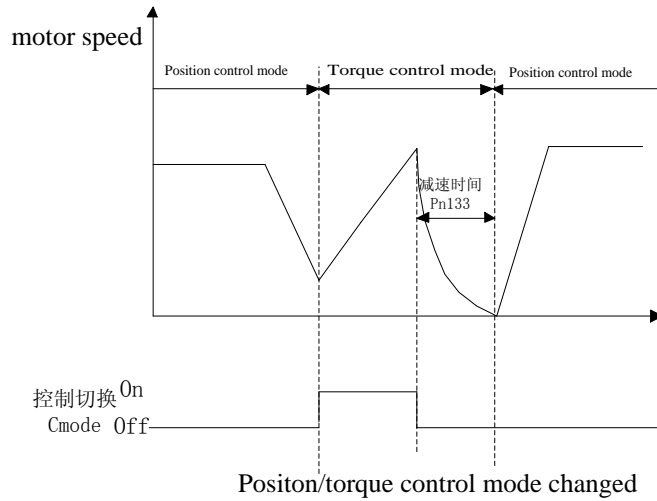

B.3 速度/转矩控制模式切换 Speed/torque control mode switch

使用控制切换(cmode), 可通过输入控制端口SigIn接点进行速度控制模式和转矩控制模式的切换。
Using the control switch (cmode), can be controlled by input port SigIn contact for speed control mode and the torque control mode switching.

cmode和控制模式的关系如下所示。Cmode relationship with control mode is shown below.

Cmode	控制模式control mode
OFF	速度控制模式position control mode
ON	转矩控制模式Torque control mode

不管何时都可以进行控制模式的切换，切换的时序图如下所示：Whenever can control mode switch, switching sequence diagram as shown below:

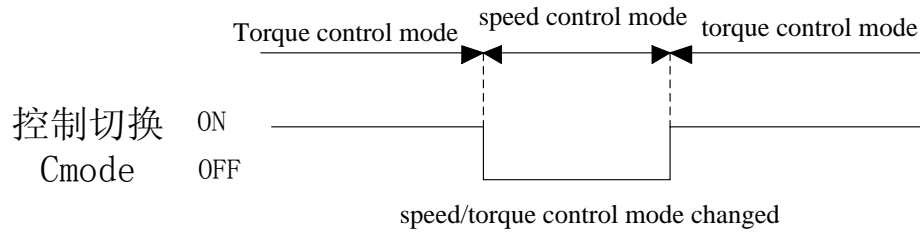

附录 C 伺服驱动器工作时序 Appendix C servo driver work sequence

C.1 电机静止时的 ON/OFF 动作时序 Motor resting ON/OFF action sequence

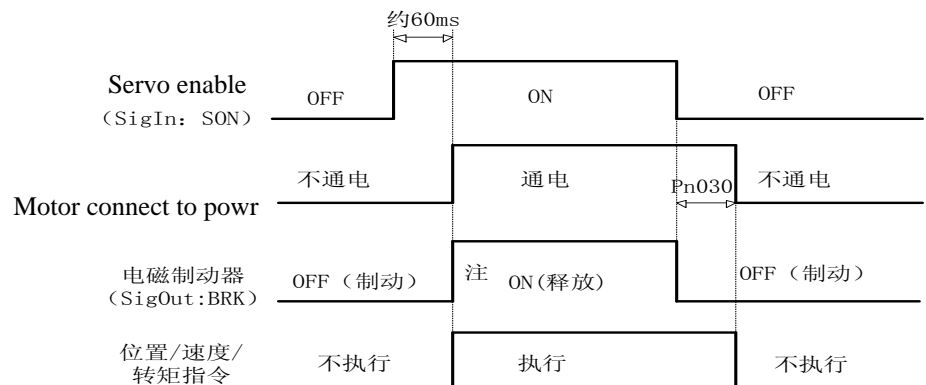

注 1: 使用电磁制动功能时, 伺服断使能方式 Pn004 必须设置为 2。Note 1: when using electromagnetic brake function, servo broken way can make Pn004 must be set to 2.

注 2: 当电机转速低于参数 Pn029 时, 电磁制动器的动作时序。Note 2: when Pn029 motor speed is lower than the argument, the electromagnetic brake action sequence.

C.2 电机运转时的 ON/OFF 动作时序 In the operation of the motor ON/OFF action sequence

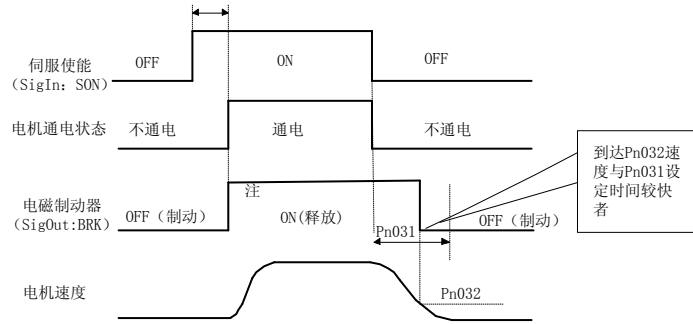

注 1: 使用电磁制动功能时, 伺服断使能方式 Pn004 必须设置为 2 Note 1: when using electromagnetic brake function, servo broken way can make Pn004 must be set to 2

注 2: 当电机转速不低于参数 Pn029 设定值时, 电磁制动器的动作时序。 Note 2: when the motor speed is not lower than Pn029 setting parameters, the electromagnetic brake action sequence.

C.3 伺服 ON 时报警的时序 When the servo ON alarm sequence

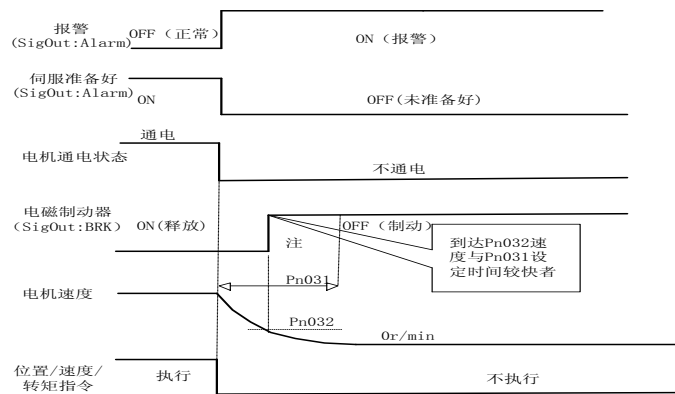

注 1: 使用电磁制动功能时, 伺服断使能方式 Pn005 必须设置为 2 Note 1: when using electromagnetic brake function, servo broken way can make Pn005 must be set to 2

附录 D 电磁制动器 Appendix D electromagnetic brake

电磁制动器（保持制动器、失电制动器），用于锁住与电机相连的垂直或倾斜工作台，防止伺服电源失去后工作台跌落。实现这个功能，须选购带制动器的电机。制动器只能用来保持工作台，绝不能用于减速和停止机器运动。 Electromagnetic brake (to keep the brakes, brake losing electricity, are connected to the motor is used to lock the vertical or inclined workbench, prevent the servo power after losing the workbench. Implement this function, you must choose and buy motor with brake. The brake can be used to keep the workbench, must not be used to slow down and stop the machine movement.

使用电磁制动器，必须设置 Pn004 参数为 2,并在 SigOut 端口指定功能。驱动器根据电机运行的转速，依照参数 Pn029 设定值，选择相应的制动时序，执行电磁制动功能。具体时序详见附录 C。Pn004 parameter must be set using the electromagnetic brake, to 2, and specify the SigOut port function. Pn029 drive according to the speed of the motor running, according to the parameters setting, choose corresponding braking time sequence, perform the function of electromagnetic brake. Please refer to the appendix C for specific timing.

附录 E 再生制动电阻 Appendix E regenerative braking resistor

当伺服电机运转在发电机模式时，电能会由电机流向驱动器，称为再生电力。以下使用情况，会使伺服电机运转在发电机(再生)模式：When servo motor running in generator mode, electricity will flow by motor drives, called renewable electricity. The following usage, can make the servo motor running in generator (renewable) mode:

- (1) 伺服电机在加减速运转时，由减速到停止期间。Servo motor, the deceleration is running by slowing down to stop.
- (2) 应用于垂直负载时。When applied to the vertical load.
- (3) 由负载端驱动伺服电机运转时。Driven by load operation of the servo motor.

此再生电力会由驱动器的主回路滤波电容吸收，但是再生电力过多时，滤波电容无法承受时，必须使用再生电阻来消耗多余的再生电能。当出现再生能量过大，内部制动电阻不能完全吸收，导致出现 AL-03(过压)、AL-08（过温）或 AL-16(制动平均功率过载)等报警。根据实际应用，增加加减速时间，若仍旧报警，就需要外接制动电阻，增强制动效果。外接制动电阻阻值范围 40~200 欧姆，功率 1000~50W，阻值越小，制动电流越大，所需制动电阻功率越大，制动能量越大，但阻值太小会可能造成损坏驱动器，试验方法是阻值由大到小，直到驱动器不再出现报警，同时运行时，制动电阻温度不太高即可。外接制动电阻时，拆去内部再生制动电阻。由于再生电阻在消耗再生电力时，会产生 100°C 以上高温，请务必小心，在连接再生电阻的电线请使用耐热不易燃的线材，并确认再生电阻没有碰触任何物品。The renewable electricity will be absorbed by the drive of the primary loop filter capacitor, but too much renewable electricity, filter capacitance cannot afford, regenerative resistor must be used to burn off excess renewable electricity. When there is a renewable energy is too large, the internal brake resistance cannot be fully absorbed, resulting in AL - 03 (overvoltage), AL - 08 (temperature) or AL - 16 (such as brake average power overload) call the police. According to the practical application, increase deceleration time, if still alarm, requires external braking resistance, enhance the braking effect. External braking resistance tolerance range of 40 ~ 200 ohms, 1000-50 w, the smaller the value, the braking current, the greater the power, the greater the braking resistance is required for braking energy is larger, but the value is too small may cause damage to the drive, resistance test method is from big to small, until the alarm is no longer present drives, running at the same time, the brake resistance temperature is not too high. When external braking resistor, down the internal regenerative braking resistor. Because regenerative resistor in the

consumption of renewable power, can produce high temperature above 100 ° C, please be careful, the connection of regenerative resistor wire please use of heat-resistant non-flammable cables, and confirm the regenerative resistor without touching anything.

注意：使用再生电阻时如果有上述报警产生，请切断电源，冷却半小时。由于再生晶体管发生故障，再生电阻异常发热，可能会造成火灾。请务必根据应用场合，选择相匹配的制动电阻。Note: if the alarm when using regenerative resistor, please cut off power supply, cooling and a half hours. Due to the regenerative transistor failure, abnormal regeneration resistance heating, may cause a fire. Please be sure to choose according to applications, matching the braking resistor.

附录 F 原点回归 Appendix F origin point

F.1 原点回归运行步骤 F.1 origin point operation steps

1: 找参考点 Looking for a reference point

启动原点回归功能后，按原点加归第一速度寻找参考点，可使用 SigIn 输入端子 REF、CCWL 或 CWL 作为参考点，也可以 Z 脉冲作为参考点，可选择正转或反转方向寻找。After start origin regression function, looking for reference point at the origin and return to the first rate, can use SigIn input terminals REF, CCWL or cwl as a reference point, can also be Z pulse as a reference point, can choose forward or reverse direction finding.

2: 找原点 find the origin

当找到参考点后，再以第二速度寻找原点，可选择继续向前或向后折返找 Z 脉冲，也可以直接以参考点作原点。When find reference point, and then to find the origin at the second speed, can choose continue to forward or backward turn-back find Z pulse, may also directly to the reference point for the origin.

原点回归执行过程中，为避免速度剧烈变化造成的机械冲击，可设置参数 Pn040、Pn041 进行加减速。找到的原点加上偏移量脉冲作为实际原点，偏移量为：
 $Pn036 * 10000 + Pn037$ 。

Origin point execution process, to avoid rapid changes of mechanical impact velocity, can be set parameters for deceleration Pn040, Pn041. Find the origin and offset pulse as actual origin, the offset is:

$Pn036 * 10000 + Pn037$ 。

原点回归参考点模式(Pn034)和原点模式(Pn035)有以下组合：The origin return reference point mode (Pn034) and the origin (Pn035) has the following combination:

Pn034 \ Pn035	0	1	2	3	4	5
0	✓(A)	✓(B)	✓(A)	✓(B)	X	X
1	✓(C)	✓(D)	X	X	X	X
2	✓(E)	✓(F)	X	X	✓(G)	✓(H)

其中✓表示原点模式组合会正常执行，X表示原点模式组合不会执行。

F.2 原点回归触发时序 The origin return to trigger sequence

Pn033	原点回归触发方式 The origin is triggered	<p>0:关闭原点回归功能 Close the origin regression function</p> <p>1: 由 SigIn 输入的 GOH 电平触发 Triggered by the GOH SigIn input level</p> <p>2: 由 SigIn 输入的 GOH 边沿触发 GOH edge triggered by SigIn input</p> <p>3: 上电自动执行一次 Electricity automatically perform again</p>
-------	----------------------------------	--

电平触发 (Pn033=1) Level trigger (Pn033 = 1)

伺服使能后，输入端子 GOH 触发原点回归执行，GOH 上边沿开始回归操作，暂停正常指令执行，下边沿结束回归操作。GOH 一直保持 ON,回归执行完后，位置偏差清零(位置控制)，输出端子 HOME 变为 ON。直到 GOH 变为 OFF,则 HOME 变为 OFF。Servo enabled, the input terminals GOH triggered the origin return to execute, GOH edge began to return to operation, the suspension of normal instruction execution, the end of the edge back to operation. GOH has kept ON, after the return to perform, position deviation reset (position control), the output terminal HOME ON. Until GOH is OFF, is HOME to OFF.

当 Pn044=0 时，原点回归完成后等待 HOME 信号 变为 OFF 后再 执行指令，等待期间电机停留在原点，不接受指令；当 Pn044=1 时，原点回归完成后立刻执指令。When Pn044 = 0, origin wait for after the completion of the HOME after the signal into a OFF again executes instructions, waiting for the motor during stay at the origin, not accept instructions; When Pn044 = 1, the origin return immediately after the completion of the instructions.

在原点回归执行中，如果取消伺服使能 SON、产生任何报警、GOH 提前变为 OFF，则原点回归功能中止且输出端子 HOME 不动作。此外，如果使能 son 有效、没有报警，回归在执行中且没有完成，即使边沿触发 (Pn033=2) 信号重复有效，则驱动器会完成当前回归操作后，再检测边沿触发信号。At the origin in the execution of regression, if cancel the servo can make SON, produce any alarm, GOH into OFF ahead of schedule, the origin of regression function suspension and output terminals HOME not action. In addition, if effective, no alarm, can make the son return in execution and there is no complete, even if the edge triggered (Pn033 = 2) repeat signals effectively, the drive will be completed the current return after operation, to detect edge trigger signal.

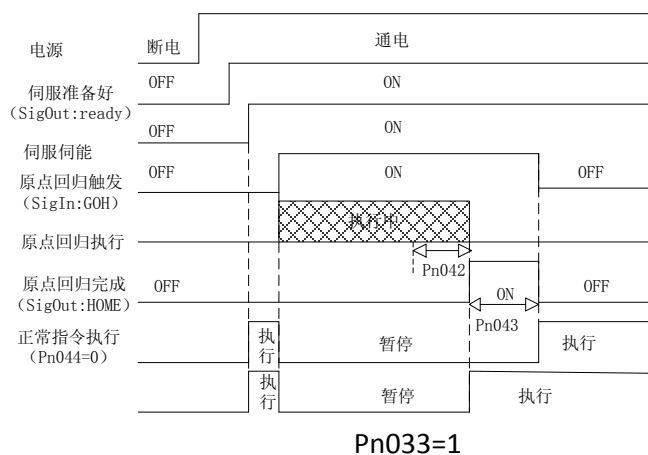

Pn033=1

边沿触发 (Pn033=2) Edge triggered (Pn033 = 2)

伺服使能后，输入端子 GOH 上升触发原点回归执行，并暂停正常指令执行 Servo enabled, the input terminals GOH rise triggered the origin return to perform, and suspension of normal instruction execution

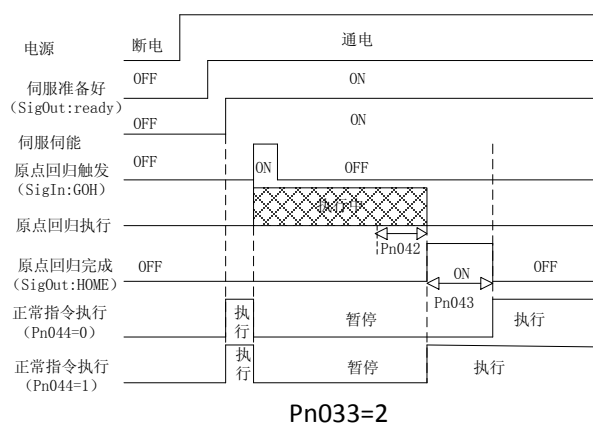

Pn033=2

上电自动执行 (Pn033=3) Electricity automatically perform (Pn033 = 3)

此功能仅于上电后伺服初次使能有效时执行一次，以后不需要重复运行原点回归的情况。每次上电，驱动器自动执行一次原点回归操作。使用此功能可以节省一个输入端子 GOH。 This function only in electric servo make effective for the first time after the execution time, later don't need to repeat the origin regression. Every time it with electricity, drive automatically perform an origin point operations. Use this feature can save one input terminal GOH.

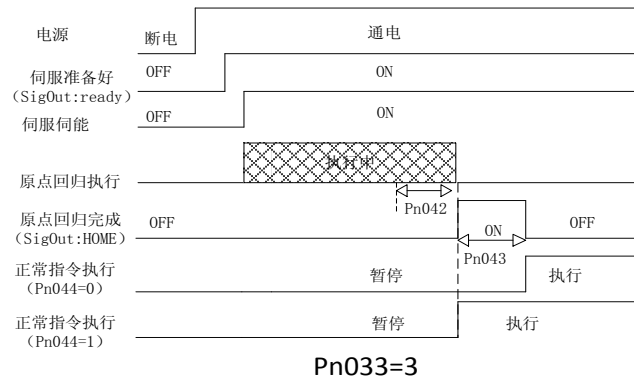

F.3 原点回归组合模式时序 The origin model time-series regression combination

Pn034	原点回归参考点模式 The origin return reference point model	<p>0:正转找 REF(上升沿触发)作参考点 Forward looking for REF (rising along the trigger) as a reference point</p> <p>1:反转找 REF(上升沿触发)作参考点 Inversion for REF (rising along the trigger) as a reference point</p> <p>2:正转找 CCWL(下降沿触发)作参考点 Forward looking for CCWL falling edge (trigger) as a reference point</p> <p>3:反转找 CWL(下降沿触发)作参考 Inversion to find.cwl falling edge (trigger) for reference</p> <p>4:正转找 Z 脉冲作参考点 Forward looking for Z pulse as a reference point</p> <p>5:反转找 Z 脉冲作参考点 Pulse inversion for Z as a reference point</p>	0~5	0
Pn035	原点回归原点模式 The origin back to the origin model	<p>0: 向后找 Z 脉冲作原点 Backward looking for Z pulse as the origin</p> <p>1: 向前找 Z 脉冲作原点 Forward looking for Z pulse as the origin</p> <p>2: 直接以参考点上升沿作原点 Directly with reference point rise along the origin</p>	0~2	0

注 1: 通过组合参数 Pn034 和 Pn035, 有 8 种可用的原点回归方式。Note 1: by combining Pn034 and Pn035 parameters, there are eight kinds of available ways of origin.

注 2: 在原点回归操作时, 将关闭正/反驱动禁止功能, 直至退出回归操作。Note 2: when operating at the origin regression will close/reverse driving ban function, until the exit to return to operation.

(A)Pn034=0 或 2,Pn035=0

参数 parameter	设定 set	说明 instruction
Pn034	0 或 2 0 or 2	原点回归启动后，按回归第一速度正转找 REF(上升沿触发)或 CCWL(下降沿触发)作参考点 Origin starts, to return to the first speed forward looking for REF (rising along the trigger) or CCWL falling edge (trigger) as a reference point
Pn035	0	到达参考点后，按回归第二速度向后找 Z 脉冲作原点 Arriving at reference points, the backward looking for Z pulse to return to the second speed as the origin

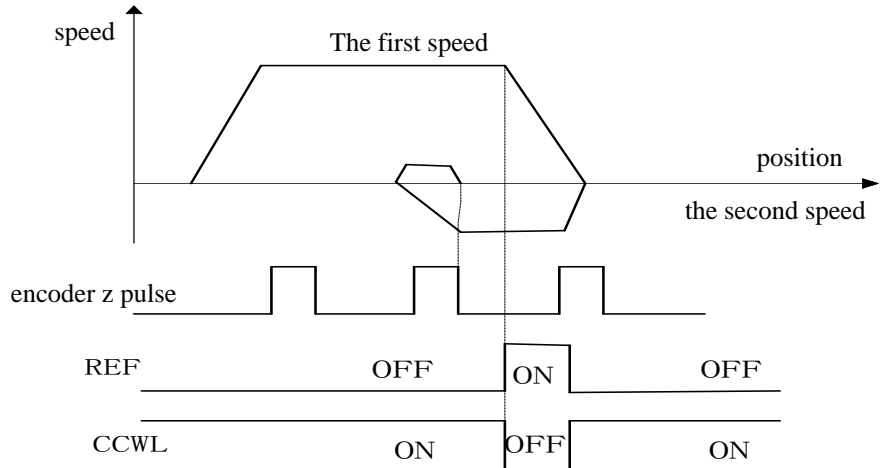

(B) Pn034=1 或 3, Pn035=0

参数 parameter	设定 set	说明 instruction
Pn034	1 或 3	原点回归启动后，按回归第一速度反转找 REF（上升沿触发）或 CWL(下降沿触发)作参考点 Origin starts, to return to the first speed inversion for REF (rising along the trigger) or.cwl falling edge (trigger) as a reference point
Pn035	0	到达参考点后，按回归第二速度向后找 Z 脉冲作原点 Arriving at reference points, the backward looking for Z pulse to return to the second speed as the origin

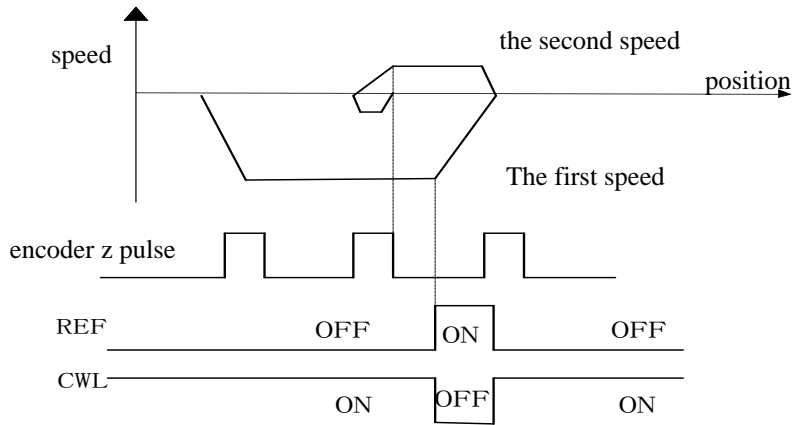

(C) Pn034=0, Pn035=1

参数 parameter	设定 set	说明 instruction
Pn034	0	原点回归启动后，按回归第一速度正转找 REF(上升沿触发)作参考点 Origin starts, to return to the first speed forward looking for REF (rising along the trigger) as a reference point
Pn035	1	到达参考点后，按回归第二速度向前找 Z 脉冲作原点 Arrived at the reference point, to return to the second speed forward looking for Z pulse as the origin

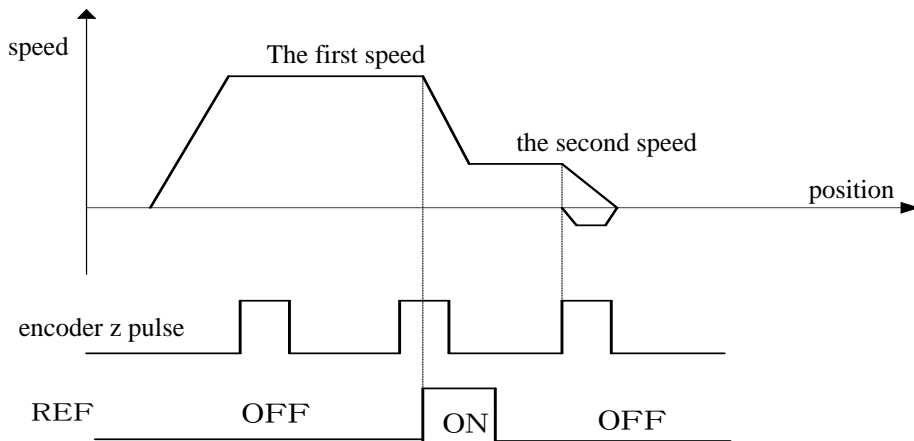

(D) Pn034=1, Pn035=1

参数 parameter	设定 set	说明 instruction
Pn034	1	原点回归启动后，按回归第一速度反转找 REF(上升沿触发)作参考点 Origin starts, to return to the first speed inversion to find the REF (rising

		along the trigger) as a reference point
Pn035	1	到达参考点后，按回归第二速度向前找 Z 脉冲作原点 Arrived at the reference point, to return to the second speed forward looking for Z pulse as the origin

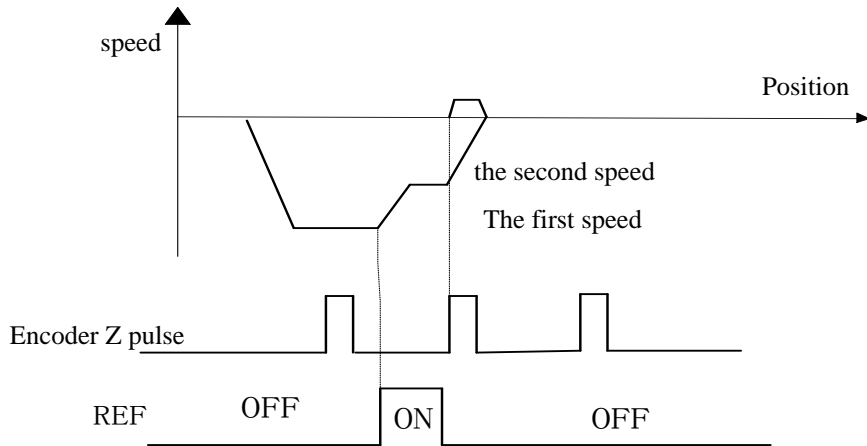

(E)Pn034=0,Pn035=2

参数 parameter	设定 set	说明 instruction
Pn034	0	原点回归启动后，按回归第一速度正转找 REF(上升沿触发)作参考点 Origin starts, to return to the first speed forward looking for REF (rising along the trigger) as a reference point
Pn035	2	到达参考点后，直接以参考点作为原点 Arriving at reference points, the direct reference point as the origin

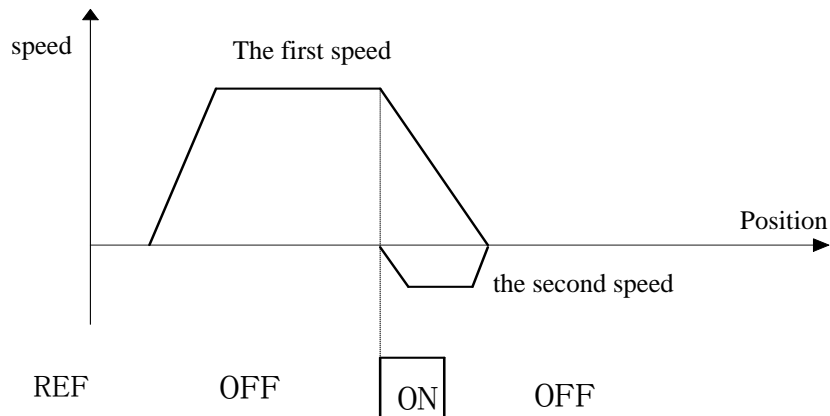

(F)Pn034=1,Pn035=2

参数 parameter	设定 set	说明 instruction
Pn034	1	原点回归启动后, 按回归第一速度反转找 REF(上升沿触发)作参考点 Origin starts, to return to the first speed inversion for REF (rising along the trigger) as a reference point
Pn035	2	到达参考点后, 直接以参考点作为原点 Arriving at reference points, the direct reference point as the origin

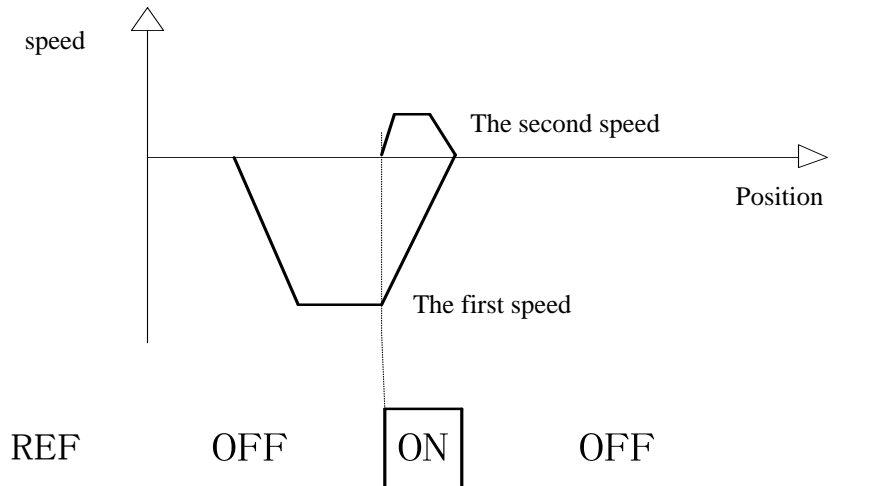

(G)Pn034=4,Pn035=2

参数 parameter	设定 set	说明 instruction
Pn034	4	原点回归启动后, 按回归第一速度正转找 Z 脉冲作参考点 Origin starts, to return to the first speed forward looking for Z pulse as a reference point
Pn035	2	到达参考点后, 直接以参考点作为原点 Arriving at reference points, the direct reference point as the origin

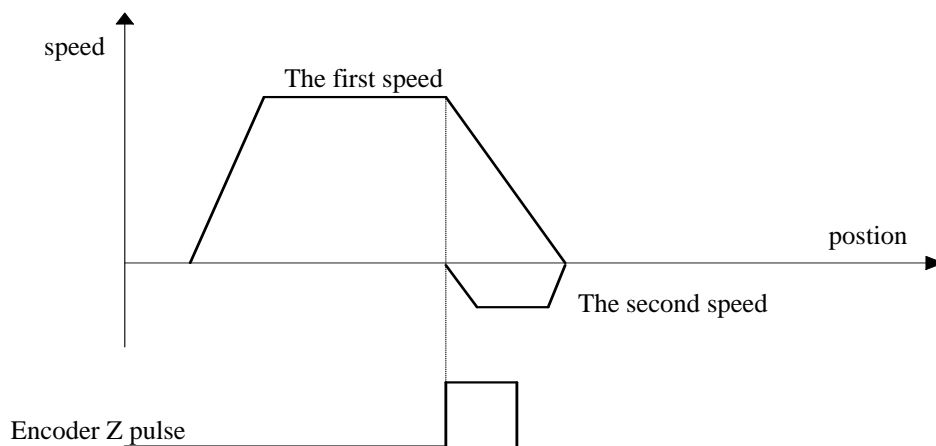

(H)Pn034=5,Pn035=2

parameter	set	instruction
Pn034	5	Origin starts, to return to the first speed pulse inversion for Z as a reference point
Pn035	2	Arriving at reference points, the direct reference point as the origin

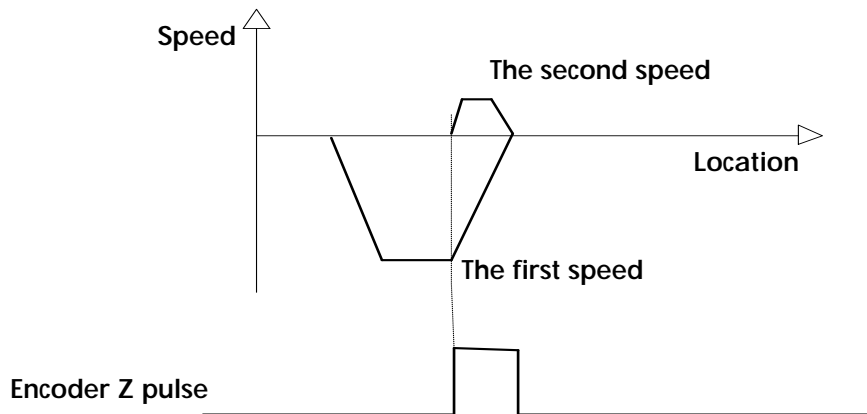

The appendix G internal position control

An internal position control, need to set Pn002 = 2, Pn117 = 1, and in Pn118 ~ Pn131 set up corresponding operation parameters.

SigIn port pos1, pos2 choose internal position command N:

Pos2	Pos1	internal location instructions N
1	1	internal location instructions 0
1	0	internal location instructions 1
0	1	internal location instructions 2
0	0	internal location instructions 3

When using internal position control, make sure the input port pos1, pos2 state, namely choose corresponding internal position command, and then trigger ptrigger input signal, each ptrigger

(OFF -> ON) falling edge, the driver will read instruction N internal position, accumulate to the rest of the order the number of pulses, continue to perform the corresponding operation.

If set Pn118 = 0, want to suspend the motor running, in the process of position when the trigger input port pstop signal, motor speed to stop, and then drive automatically remove residual position instruction, when the input port ptriger fire again, the drive will be based on the current pos1, pos2 state, execute the position of the corresponding instructions, please refer to the following sequence diagram:

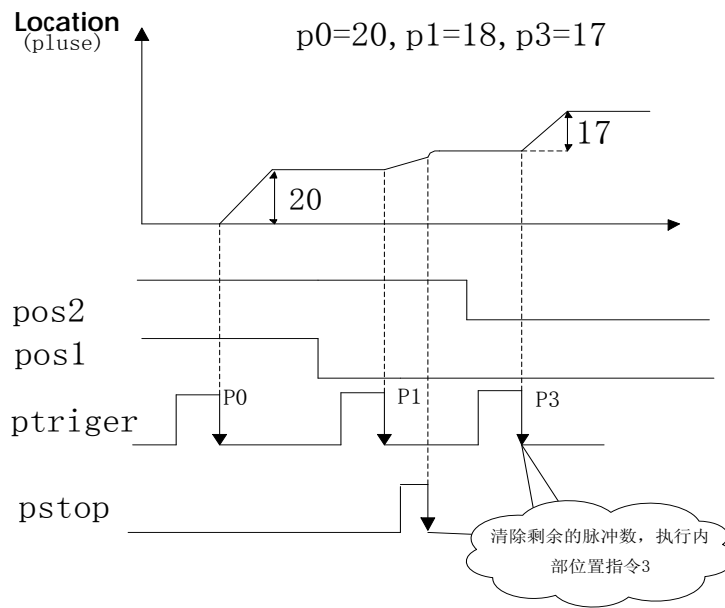

If set Pn118 = 1, want to pause in the process of the position the motor running, when the trigger input port pstop signal, motor speed to stop, when the input port ptriger fire again, the location of the electricity opportunities continue to walk the remaining instructions, the input port pstop trigger issued before the target location, please refer to the following sequence diagram:

