

User Manual

For

3rd TB6560

4 Axis Standard & Professional Stepper Driver Set



Attention: Please read the manual carefully before using the products!

ECG Safety Statement

Easy Commercial Global is not liable or responsible for any accidents, injuries, equipment damage, property damage, loss of money or loss of time resulting from improper use of electrical, mechanical or software products sold on this website or other Easy Commercial Global sales resources.

Since Easy Commercial Global basically provides OEM machine assembly components to build their machines for their own use or third party use, it is their responsibilities to maintain certify and comply with the end user products built base on our components sold at this website or other Easy Commercial Global sales resources.

Assembling electrical CNC machine component like power supplies, motors, drivers or other electrical components involves dealing with high voltage like AC alternative current or DC direct current that is extremely dangerous. Thus, more attention & essential experience and knowledge of software, electricity, electro-mechanics & or mechanics must be necessary.

For technical questions please contact us at ebay@savebase.com before purchase.

2012 Easy Commercial Global Technology Corporation Limited

All Rights Reserved

1. Introduction, Features and Applications

I. Introduction

The latest 3rd generation TB6565 Stepper Driver has been upgraded to the intelligent, professional and industrial-level drive set by re-designing the PCB board, embedding intelligent memory chip(professional version) and upgrading the external manual control tools (display panel and control pad).

Actually, the 3rd generation TB6565 Stepper Driver has two types of version, one is the standard version, and another is the professional version. Compare to the standard version, the professional version mainly has two more functions than the standard version, one is the “computer G-code recording function”, and another is the “manual programing function”. Except these two functions, these two types of versions have no other differences.

Firstly, both of these two types of versions have upgraded their PCB boards, the re-designing the PCB board will avoid the TB6560 chip on the board being easily blown as the previous version.

With the embedded intelligent memory chip, the professional version of this 3rd generation 4 Axis TB6565 Stepper Driver can easily record the G-code running on the CNC software (e.g. Mach3, EMC2, KCAM4, etc..) of the computer, and then rerun the recorded G-code to make the stepper motor work without the computer any more.

Furthermore, the upgraded external manual control tools (display panel and control pad) on the professional version can be not only used for manually controlling the stepper motor, but also manually programming the G-code. All the manually Programmed G-code will also be recorded in to the embedded intelligent memory chip, and then we also can easily run the recorded G-code to control the stepper motor. Considering that the computer G-code recording function is enough for all the four axis working without computer, to avoid repeated function, the manual programming function is mainly designed for one axis to make linear motion, therefore, the four axis cannot be manually programmed simultaneously. This function is widely used on working which just need one Axis, such as RBI machine, Conveyor etc.

Lately, both of these two types of versions adopt the totally enclosed optical isolation and bipolar constant-current chopper to insure working at low noise & vibration, and avoid creeping at a low speed. It is very suitable for driving the 2-phase and 4-phase hybrid stepping motors.

In short, the qualities and functions of the new 3rd generation advanced 4 Axis TB6565 Stepper Driver are revolutionized from the previous version. So, we believe that these two types of versions must satisfy different users on CNC DIY.

II. Features

- High performance, cost-effective
- Automatic idle-current reduction
- To manually control the stepper motor, both of the standard and professional drivers have been equipped with the display panel and control pad.
- Automatically identify both of the computer and control pad, functions of the computer and control pad can be switched intelligently for each other without any interference.
- Display panel can real-time trail the running path of G-Code on the computer or input by the control pad, and then completely and Simultaneous display the changing of each axis'(X, Y, Z, A axis etc.) values on its screen.
- The professional version can automatically trail the path running path of G-Code from the CNC software (e.g. Mach3, EMC2, KCAM4, etc...) of the computer and record the G-code into the memory chip; Easy to repeatedly run the G-code to control the stepper motors without computer
- The professional version also support manual programming via the control pad, as long as input the required values on one axis and record them in the memory chip of the driver, and then run these recorded values to drive the axis to make linear motion, widely used on RBI machine, Conveyor and so on.
- Automatically finish Tool-settings on X, Y, Z Axis via the control pad, without the support of the computer
- Compatible with all the motors with 0.5A-3.5A (peak) rated current, four types of adjustable output current can be set on the driver board.

- 1, 2, 8, 16 adjustable microstep control, motors run more precisely and smoothly.
- Overload, overcurrent, overvoltage, overheat protection to avoid damaging your computer and devices.
- Totally enclosed optical isolation and bipolar constant-current chopper to insure motors work at low noise & vibration, and avoid motors creep at a low speed.
- With one 0-10V PWM Signal output port for speed adjustment and one Relay control port.
- 5 types of input control in manual control interface, to set Limit, Estop, Midpoint-Setting, Cutter-presetting/Tool-Setting etc...
- Cooling Aluminium box Design for Cooling, and protect the driver board from being damaged by dirt, dust or other liquids.

III. Applications

Suitable for a wide range of 2-phase and 4-phase hybrid stepping motors, from NEMA size 17 to 34. It can be used in various kinds of machines, such as X-Y tables, labeling machines, laser cutters, engraving machines, pick-place devices, and so on.

Particularly adapt to the applications desired with low noise, low heating, and high speed performance.

2. Specifications

I. Electrical Specifications ($T_j = 25^{\circ}\text{C}/77^{\circ}\text{F}$)

Input voltage	12V-36V DC
Output current	0.5A-3.5A (Peak)
Drive type	Pulse + Direction + Enable Signal Control (Bipolar constant-current PWM output)
Suitable motor	Nema17, Nema23, Nema24, Nema34 (Rated current: 0.5A-3.5A)
Net weight	725g (Driver)
Dimensions	177*173*46mm

II. Operating Environment and other Specifications

Cooling	Natural Cooling or Fan Forced cooling	
Operating Environment	Environment	Avoid dust, oil fog and corrosive gases
	Ambient Temperature	0 °C — 50°C (32°F — 122°F)
	Humidity	40%RH — 90%RH
	Operating Temperature	70°C (158°F) Max
Storage Temperature	-20 °C — 65°C (-4°F — 149°F)	
Total Weight	Approx. 840g (Driver + Control Pad + Display Panel)	

III. PCB Instructions & Specifications (unit: mm)

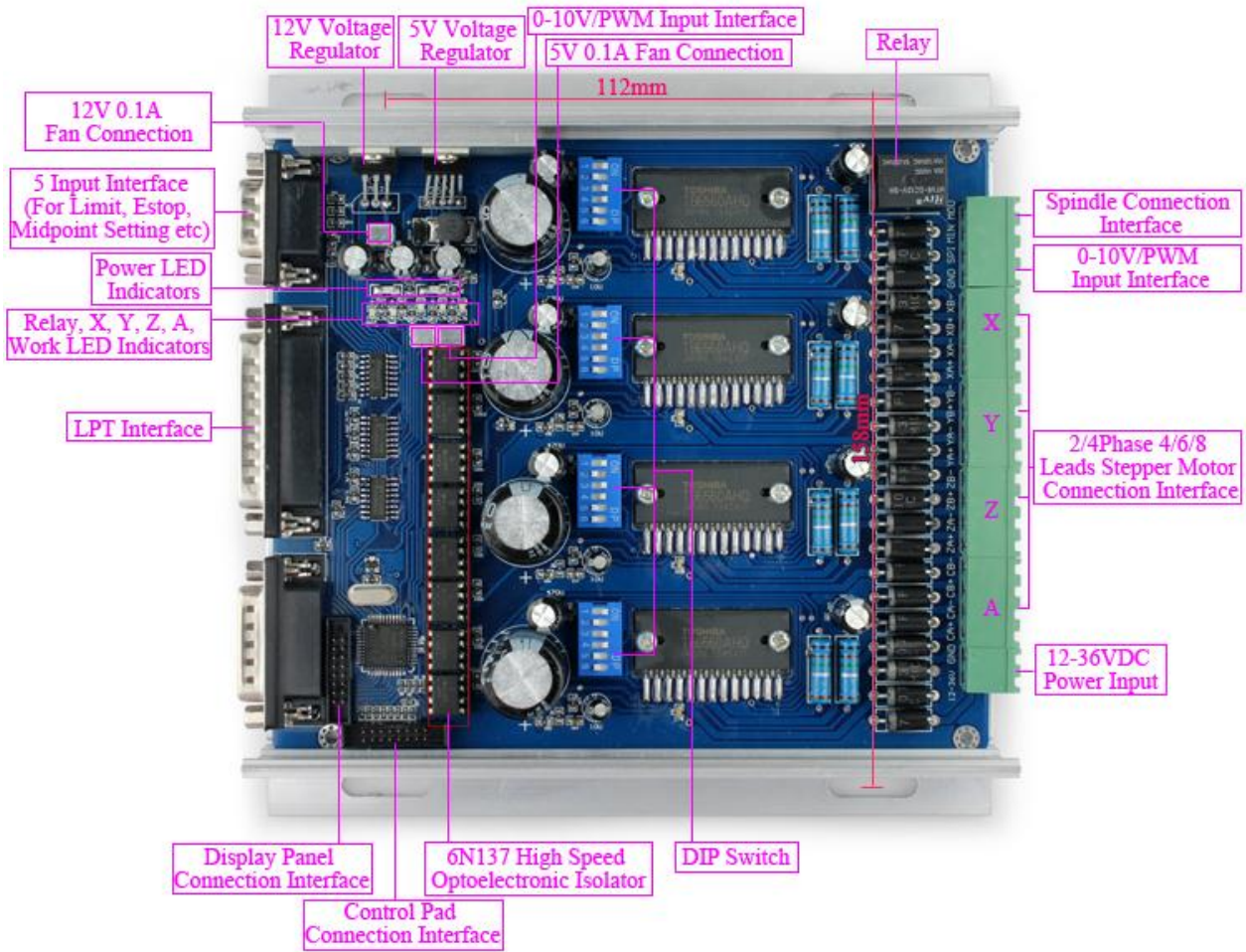
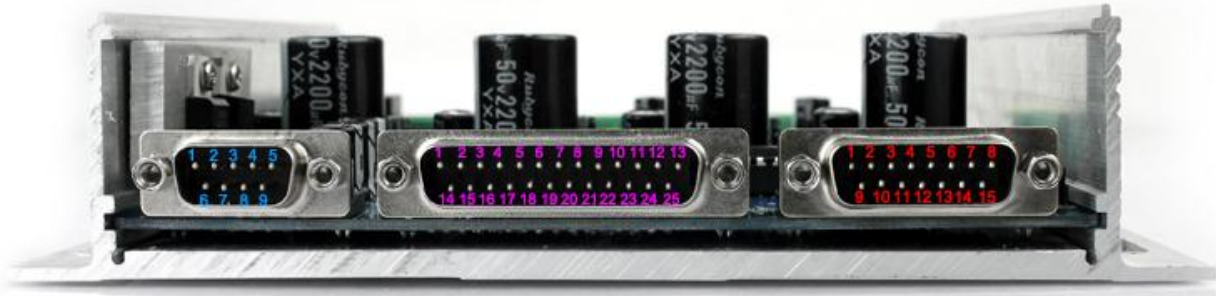

Figure 1: PCB Instructions & Specifications

3. Pin Assignment & Connectors Definitions

I. DB25 & DB9 definitions



DB9:

- P1: X Axis Limit
(Correspond to Pin15)
- P2: Y Axis Limit
(Correspond to Pin10)
- P3: Z Axis Limit
(Correspond to Pin11)
- P4: A Axis Limit
(Correspond to Pin12)
- P5: Emergency Stop(Estop)
(Correspond to Pin13)
- P6: GND
- P7: GND
- P8: GND
- P9: GND

DB25:

- Pin1: All X, Y, Z Axis Enable Input
- Pin2: X Axis Direction Input
- Pin3: X Axis Pulse Input
- Pin4: Y Axis Direction Input
- Pin5: Y Axis Pulse Input
- Pin6: Z Axis Direction Input
- Pin7: Z Axis Pulse Input
- Pin8: A Axis Direction Input
- Pin9: A Axis Pulse Input
- Pin10: LPT Signal Input/Y Axis Limit
- Pin11: LPT Signal Input/Z Axis Limit
- Pin12: LPT Signal Input/A Axis Limit
- Pin13: LPT Signal Input/Estop
- Pin14: Relay Signal Input (Spindle)
- Pin15: LPT Signal Input/X Axis Limit
- Pin16: 0-10V PWM Signal Input
- Pin17: N/A
- Pin18: GND
- Pin19: GND
- Pin20: GND
- Pin21: GND
- Pin22: GND
- Pin23: GND
- Pin24: GND
- Pin25: GND

DB15:

Serial communication interface,
no precise definitions.

Figure 2: DB25 & DB9 definitions

II. Connectors Definitions:

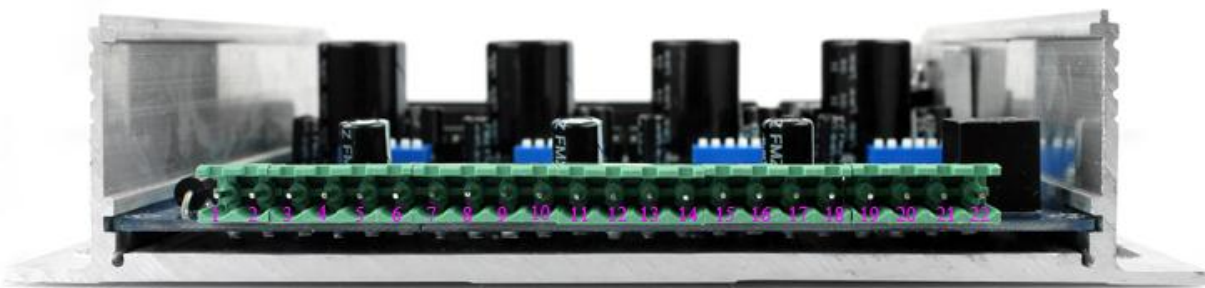

- | | | | |
|--------------|---------|---------|---------|
| 1. 12-36V(+) | 7. ZA+ | 13. YB+ | 19. GND |
| 2. GND (-) | 8. ZA- | 14. YB- | 20. PWM |
| 3. AA+ | 9. ZB+ | 15. XA+ | 21. R1 |
| 4. AA- | 10. ZB- | 16. XA- | 22. R2 |
| 5. AB+ | 11. YA+ | 17. XB+ | |
| 6. AB- | 12. YA- | 18. XB- | |

Figure 3: Connections Definitions

4. Working Principle

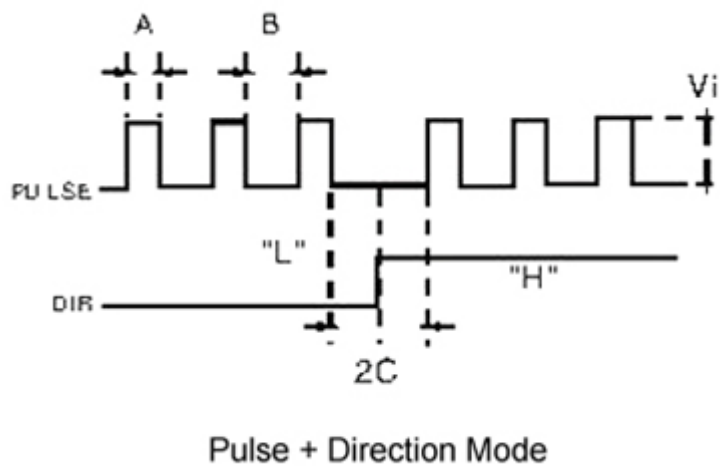

Figure 4: Working Principle

5. Selections & Connections about the Motors

The 3rd generation TB6560 stepper driver can drive 2-phase and 4-phase hybrid stepping motors, including 4, 6 or 8 leads.

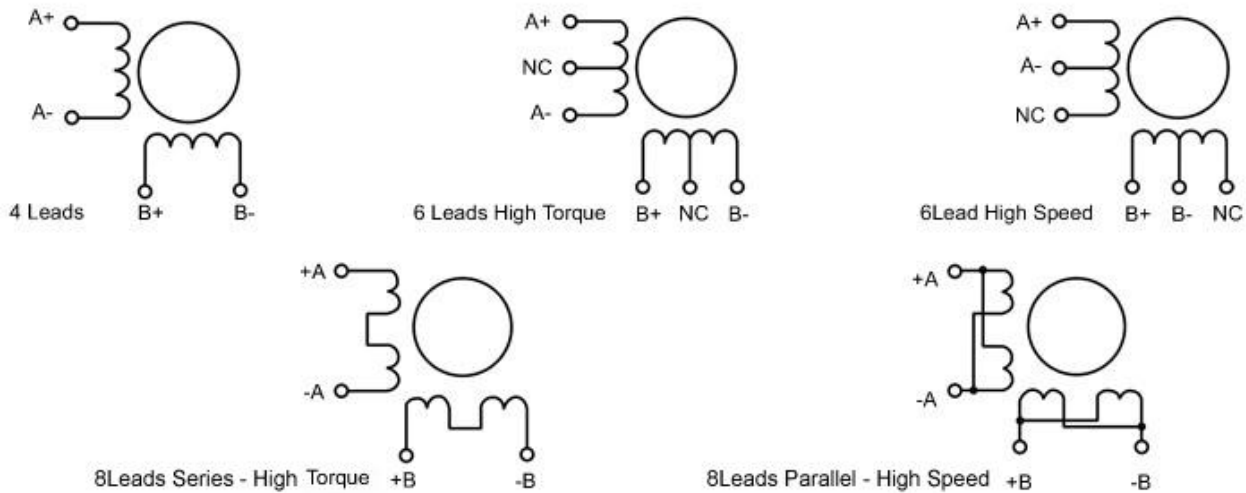

Figure 5: Wiring diagrams for 4/6/8 leads motors

I. Connections of 4-lead Motors

4 lead motors are the least flexible but easiest to wire. Speed and torque will depend on winding inductance. In theory, during adjusting stepper driver's output current, the output current can be set to 1.4 times than the rated current of the motor on the premise that the 1.4 times of rated current is lower than the TB6560 chip's 3.5A peak current.

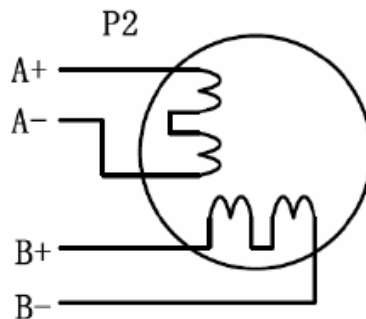

Figure 6: 4-lead Motor Connections

II. Connections of 6-lead Motors

Like 8 lead stepping motors, 6 lead motors have two configurations available for high speed or high torque operation. The higher speed configuration, or half coil, is so described because it uses one half of the motor's inductor windings. The higher torque configuration, or full coil, uses the full windings of the phases.

i. Half Coil Configurations

As previously stated, the half coil configuration uses 50% of the motor phase windings. This gives lower inductance, hence, lower torque output. Like the parallel connection of 8 lead motor, the torque output will be more stable at higher speeds. This configuration is also referred to as half chopper. In setting the driver output current multiply the specified per phase (or unipolar) current rating by 1.4 to determine the peak output current.

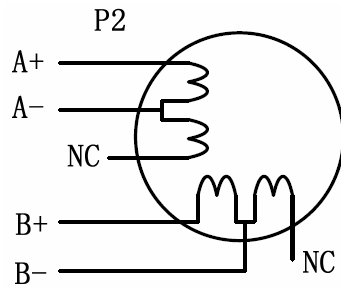

Figure 7: 6-lead motor half coil (higher speed) connections

ii. Full Coil Configurations

The full coil configuration on a six lead motor should be used in applications where higher torque at lower speeds is desired. This configuration is also referred to as full copper. In full coil mode, the motors should be run at only 70% of their rated current to prevent over heating.

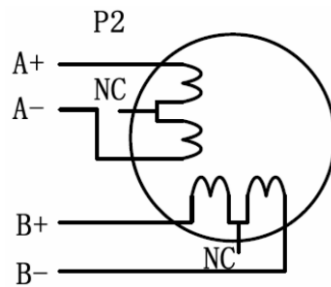

Figure 8: 6-lead motor full coil (higher torque) connections

III. Connections of 8-lead Motors

8 lead motors offer a high degree of flexibility to the system designer in that they may be connected in series or parallel, thus satisfying a wide range of applications.

i. Series Connections

A series motor configuration would typically be used in applications where a higher torque at lower speeds is required. Because this configuration has the most inductance, the performance will start to degrade at higher speeds. In series mode, the motors should also be run at only 70% of their rated current to prevent over heating.

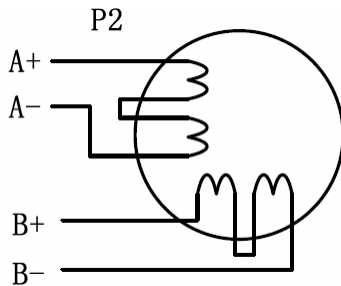

Figure 9: 8-lead motor series (higher torque) connections

ii. Parallel Connections

An 8 lead motor in a parallel configuration offers a more stable, but lower torque at lower speeds. But because of the lower inductance, there will be higher torque at higher speeds. Multiply per phase (or unipolar) current rating by 1.96, or the bipolar current rating by 1.4, to determine the peak output current.

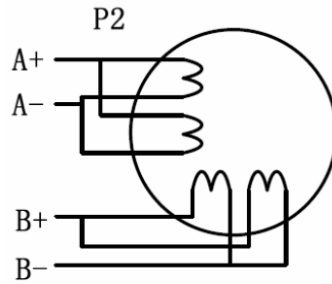

Figure 10: 8-lead motor parallel (higher speed) connections

6. Power Supply Selection

The 3rd Generation TB6560 stepper driver can match Large and small size stepping motors (from Nema size 17 to 34) made by us or other motor manufactures around the world, as long as the rated current of the motors is within **0.5-3.5A(Peak Current)** . To achieve good driving performances, it is important to select supply voltage and output current properly. Generally speaking, supply voltage determines the high speed performance of the motor, while output current determines the output torque of the driven motor (particularly at lower speed). Higher supply voltage will allow higher motor speed to be achieved, at the price of more noise and heating. If the motion speed requirement is low, it's better to use lower supply voltage to decrease noise, heating and improve reliability.

i. Regulated or Unregulated Power Supply

Both of regulated and unregulated DC power supplies can be used to supply 3rd Generation TB6560 stepper driver. However, unregulated power supplies are preferred due to their ability to withstand current surge. If regulated power supplies (such as most off switching supplies.) are indeed used, it is important to have large current output rating to avoid problems like current clamp, for example using 4A supply for 3A motor-driver operation. On the other hand, if unregulated supply is used, one may use a power supply of lower current rating than that of motor (typically 50%~70% of motor current). The reason is that the driver draws current from the power supply capacitor of the unregulated supply only during the ON duration of the PWM cycle, but not during the OFF duration. Therefore, the average current withdrawn from power supply is considerably less than motor current. For example, two 3A motors can be well supplied by one power supply of 4A rating. Although the unregulated power supplies are preferred, considering the cost, the cheap and easy-to-use regulated switching supplies in the market is also a good choice for the 3rd Generation TB6560 stepper driver and motors, as long as the total output current of the regulated switching supplies is larger than the motor's total rated current. Anyway, if users don't know how to select the suitable power supplies for the 3rd Generation TB6560 stepper driver and motors, please feel free to contact with us for assistances.

ii. Selecting Supply Voltage

The 3rd generation TB6560 stepper driver can actually operate within 12~36VDC for different motors. Higher supply voltage can increase motor torque at higher speeds, thus helpful for avoiding losing steps. However, higher voltage may cause more motor vibration at lower speed, and it may also cause motor overheat and drive damage. Therefore, it is suggested to choose 12-16VDC supply to power the Nema17 motors, 16-24V supply to power the Nema23/24 motors and 24V-36V supply to power the Nema34 Motors.

7. DIP Switches Settings (Microstep, Decay Mode, Current)

This driver adopts a 6-bit DIP switch to set microstep resolution, decay mode (buffer) and motor operating current, as shown below:

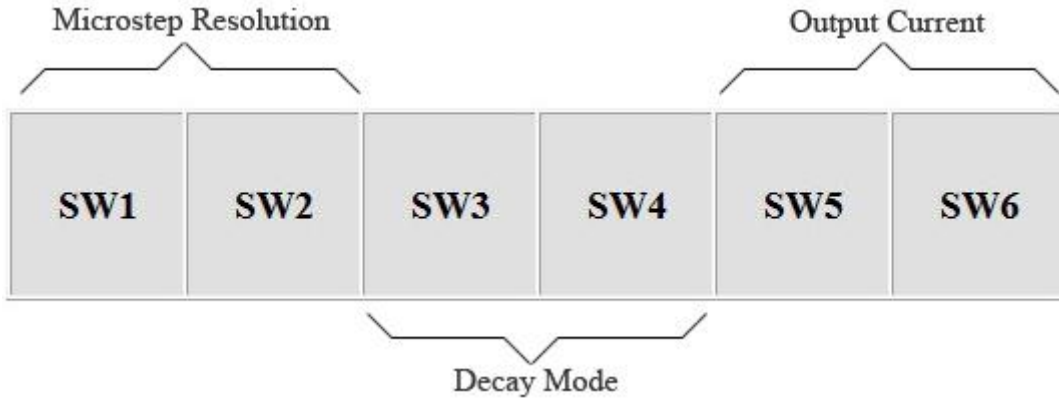

Figure 11: DIP Switches Settings

Microstep Resolution Selection:

Microstep Resolution	SW1	SW2
1	ON	ON
2	OFF	ON
8	OFF	OFF
16	ON	OFF

Decay Mode (Buffer) Selection:

Decay Mode (Buffer)	SW3	SW4
25%	ON	ON
50%	OFF	ON
75%	ON	OFF
100%	OFF	OFF

Output Current Selection:

Output Current	SW5	SW6
100%	ON	ON
75%	OFF	ON
50%	ON	OFF
25%	OFF	OFF

8. Wiring Notes

- In order to improve anti-interference performance of the driver, it is recommended to use twisted pair shield cable.
- Please shut down the power before plugging or unplugging the connectors from the driver.

9. Wiring Diagram for Reference

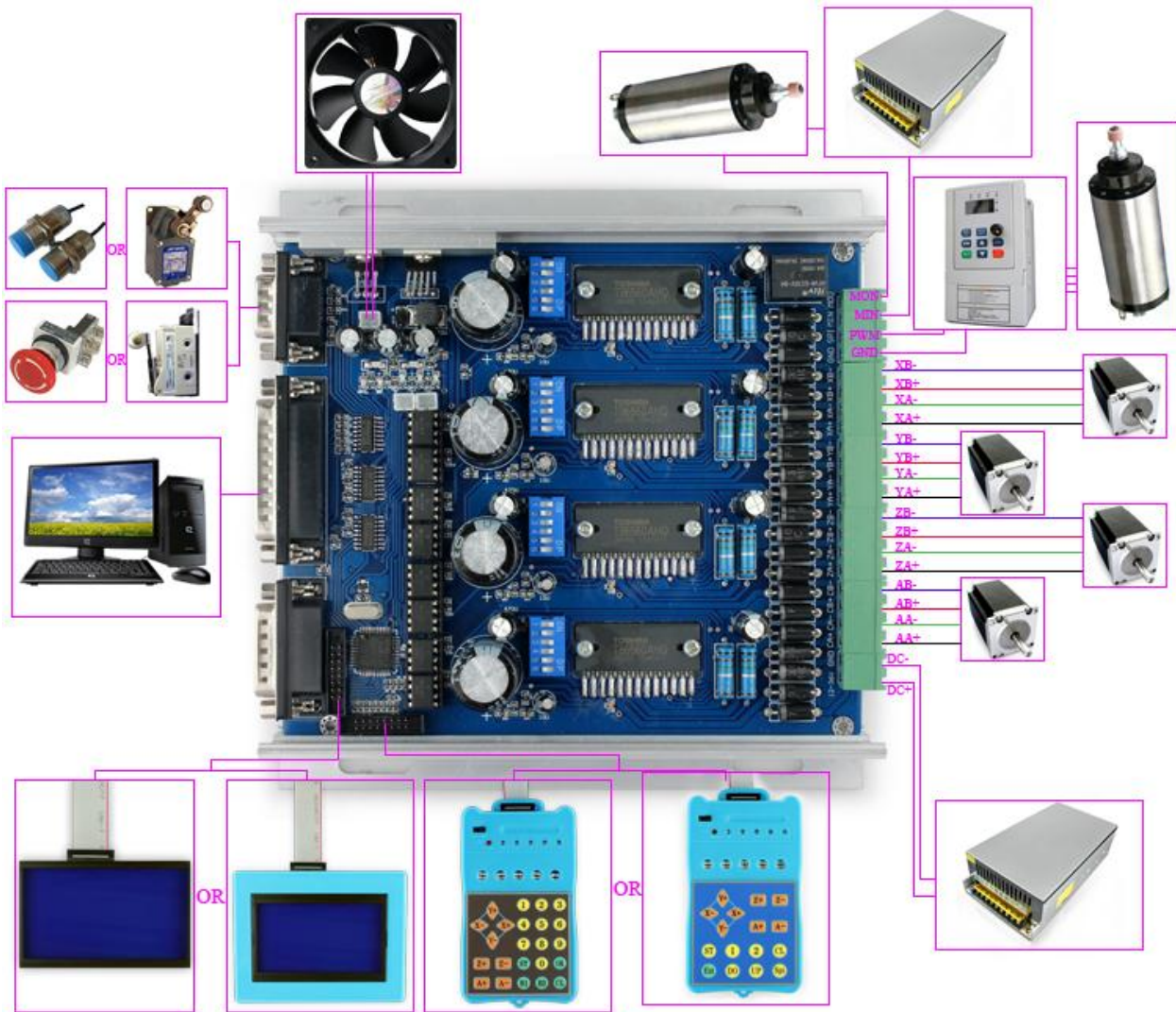

Figure 12: Wiring Diagram

10. Operation:

I. Hardware Operation (See “Hardware_Operation. PDF” in CD)

II. Software Operation

Mach3 Usage:

Figure 13: After installing Mach3 software, run “MACH3.exe” file, choose “Mach3mill”, and click “OK”.

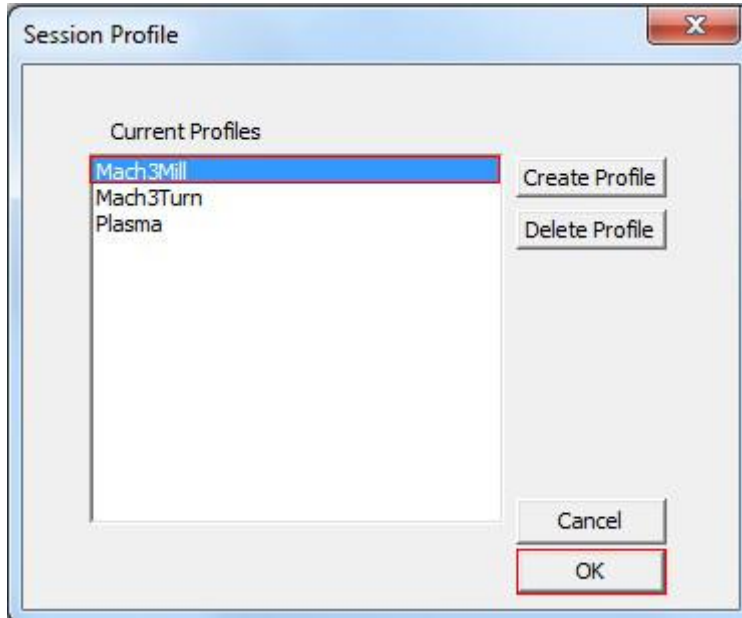

Figure 13

Figure 14: After clicking “OK”, Mach3 Main Interface shows as below.

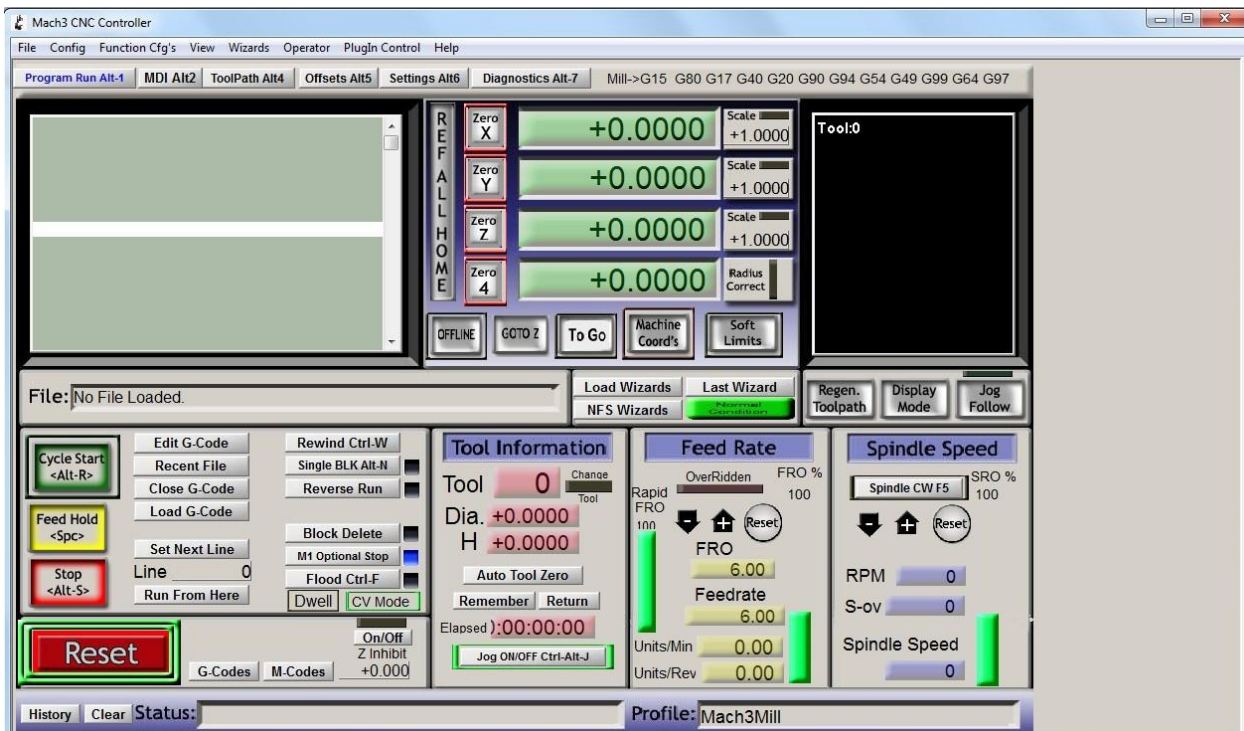

Figure 14

Figure 15: Click “Config” ----- “Ports and Pins” on Main Interface.

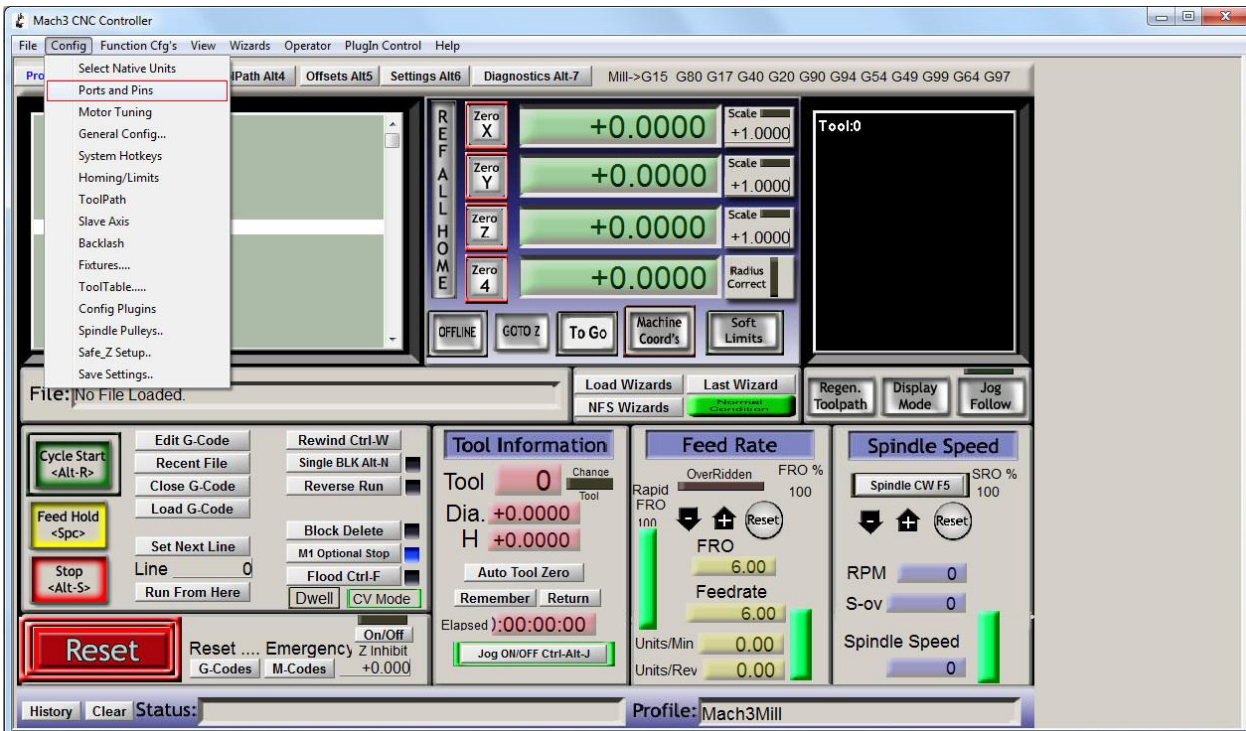

Figure 15

Figure 16: Enter in “Port Setup and Axis Selection” to set “Port #1” and “Kernel Speed” shown as below. Please make sure the Port Address in PC System Bios is the same as that in the following Figure 4 (e.g. 0x378).

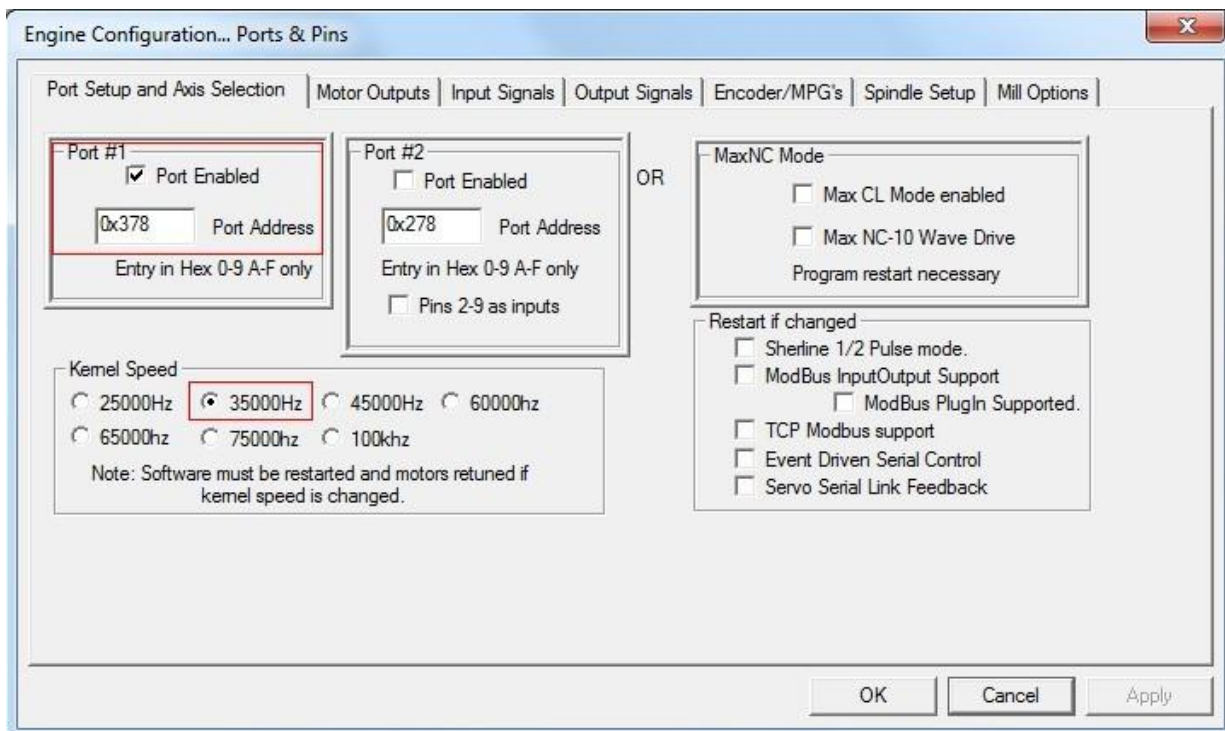

Figure 16

Figure 17: Click “Motor Outputs” to set it shown as below.

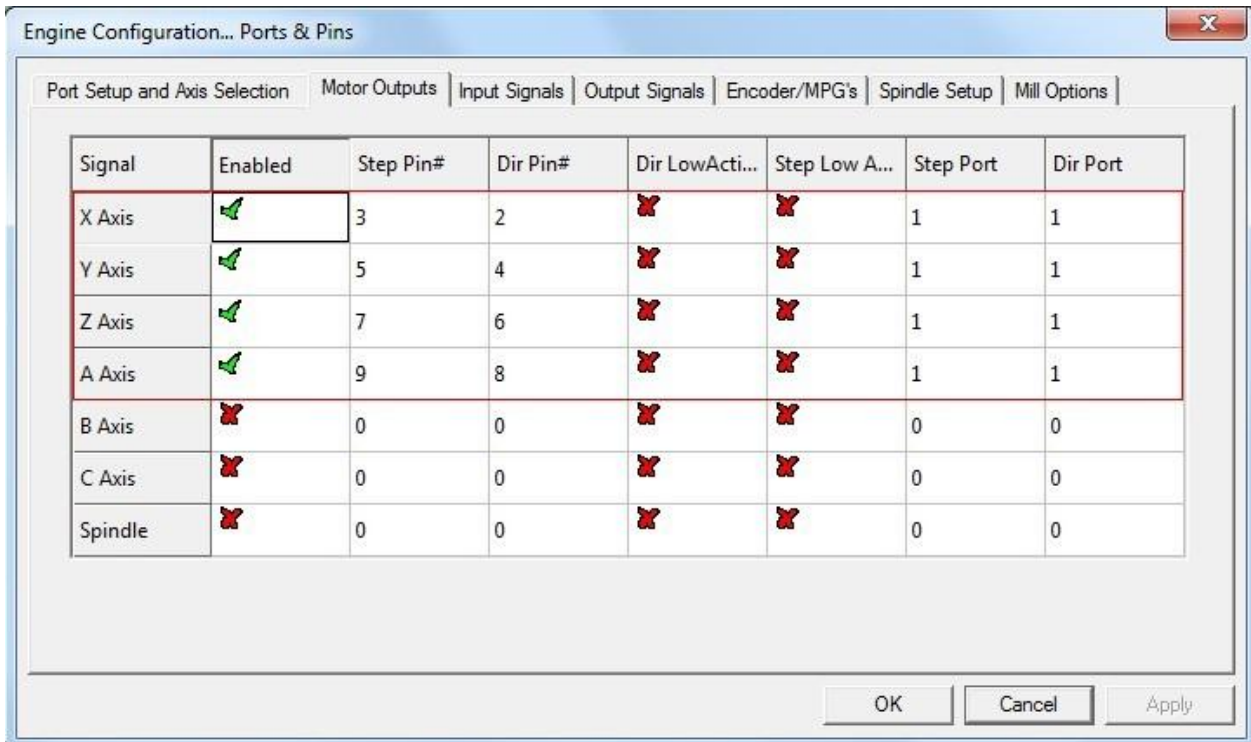

Figure 17

Figure 18: Click “Output Signals” to set it shown as below.

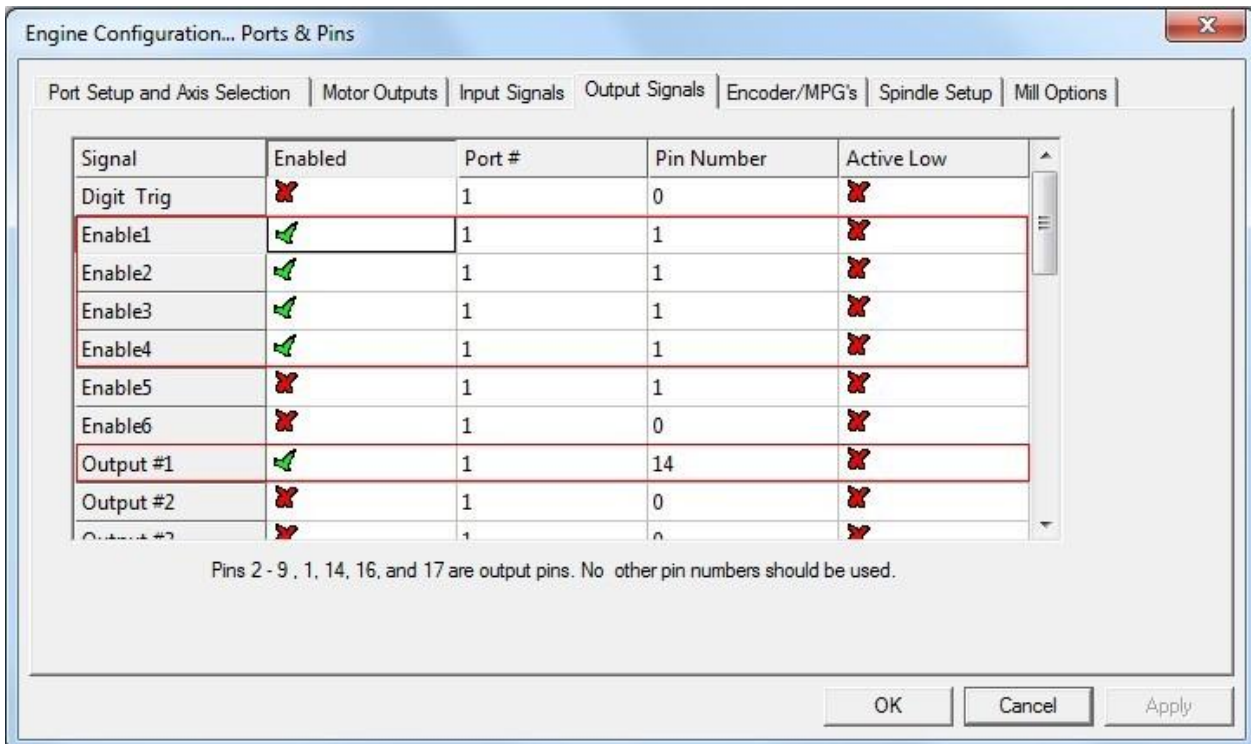

Figure 18

Figure 19: Click “File” to select “Load G-code” on Menu to enter in “GCode” file in Mach3 folder’s root directory.

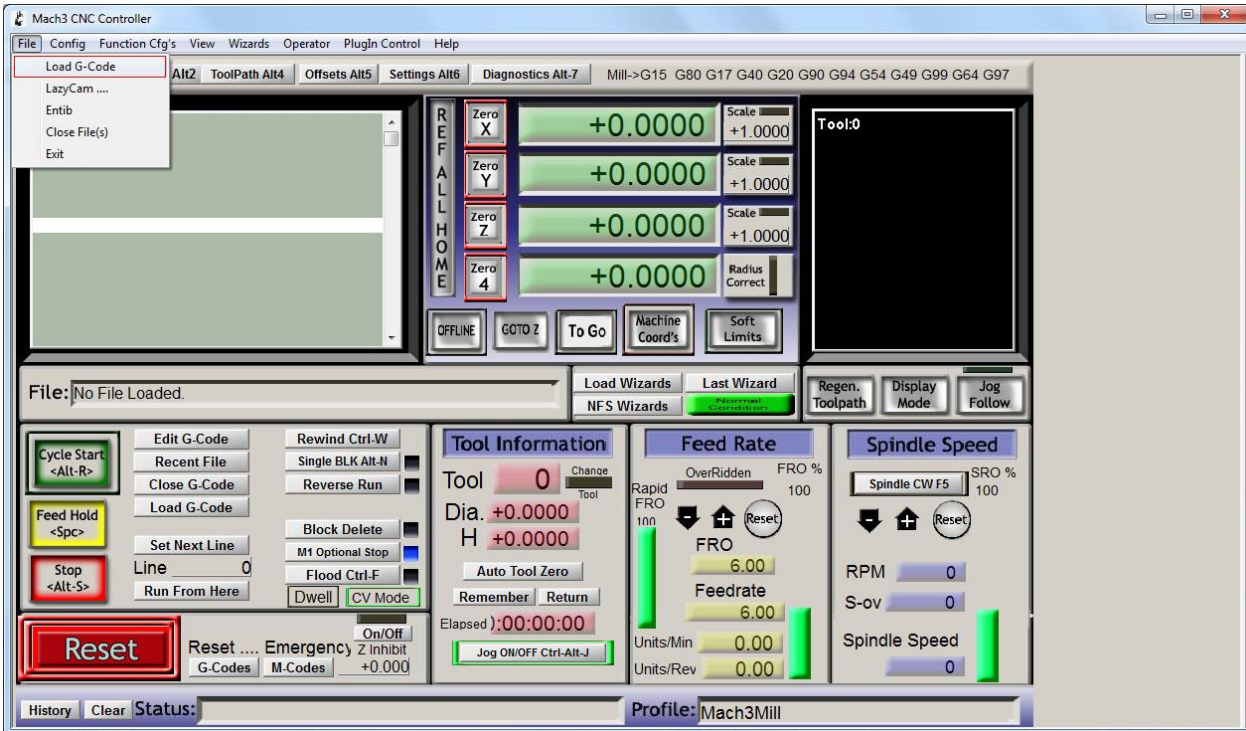

Figure 19

Figure 20: Select the “roadrunner.tap” and “Open” it.

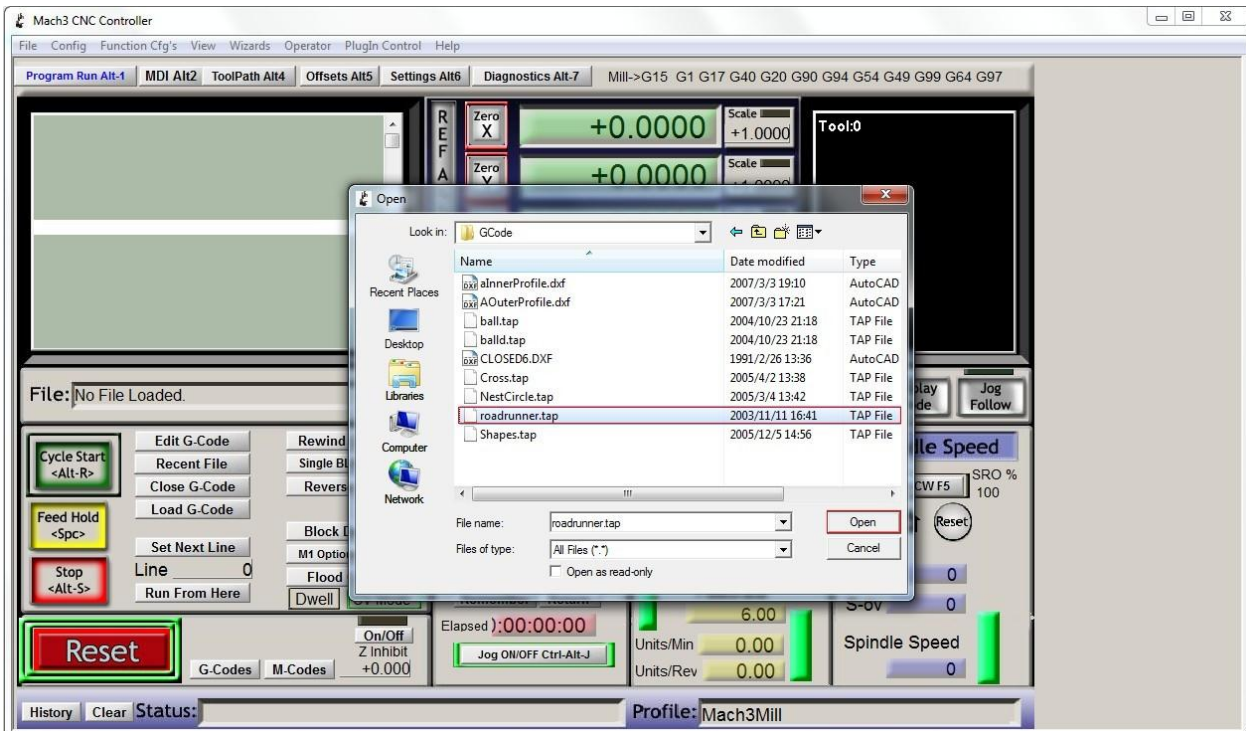

Figure 20

Figure 21: After opening the G-Code, if the “Reset” button below flashes, please press the “Reset” button, it will stop flashing, and then press the “Cycle Start” to rerun the G-Code to test the TB6560 stepper drivers and motors.

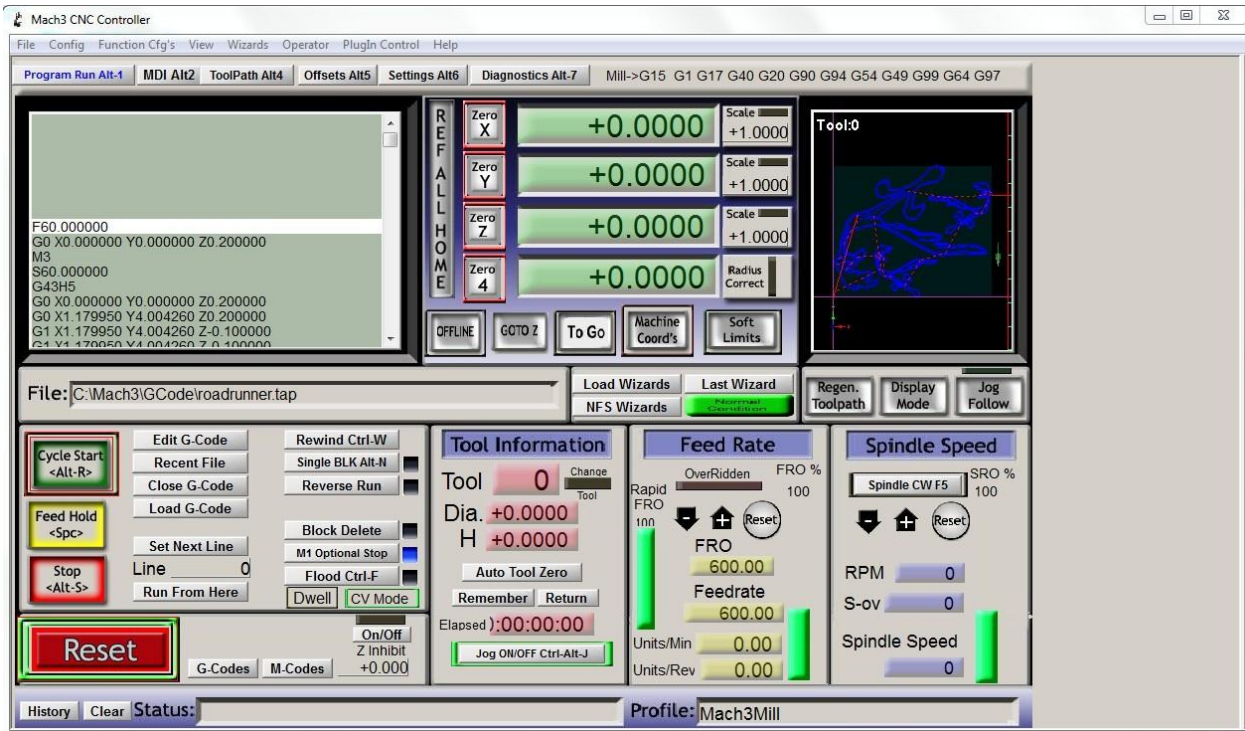

Figure 21

11. Frequently Asked Technical Questions

Many of the problems that affect motion control systems can be traced to incorrect wirings, controller software errors, and so on. In the event that your driver doesn't operate properly, the first step is to identify whether you can solve the problem via refer to the following "Frequently Asked Technical Questions" table. After checking by you, but the problem persists, or if you have any other questions, please feel free to contact with us.

Frequently Asked Technical Questions	
Symptoms	Possible Problem
Motor cannot run	➤ No power or unsuitable power supply
	➤ Incorrect wirings among the motor, driver, and power supply
	➤ Incorrect DIP switch current settings
	➤ Incorrect settings on Mach3 or other software
	➤ The driver board is disable
Motor runs in wrong direction	➤ Motors' wires may be connected in reverse
	➤ Incorrect settings on Mach3 or other software
	➤ Faulty Motor's coils
The Driver is faulty	➤ Incorrect wrings between the driver and power supply
	➤ Faulty power supply causes no power
	➤ The TB6560 chip is blown by incorrect operation
The TB6560 chip is blown	➤ Unsuitable power supply causes too high input voltage for the chip
	➤ Incorrect wirings among the motor, driver, and power supply
	➤ Impurities on the PCB board cause short circuit
	➤ Plug, unplug any connectors or connect any wires without shutting down power
	➤ Set the DIP switches when the driver is working
Erratic motor's motion	➤ Unsuitable power supply, low voltage, low current cause weak signals transmission
	➤ Incorrect DIP switch settings
	➤ Unsuitable driver for the motor
	➤ Unsuitable settings on Mach3(Motor turning and setup) or other software
	➤ The motor is faulty
Motor stalls during acceleration	➤ Unsuitable power supply, too low output voltage and current
	➤ Motor is undersized for the application
	➤ Acceleration on Mach3 (Motor turning and setup) or other software is set too high
Motor or driver overheat	➤ Unsuitable power supply, too high input voltage
	➤ Motor and driver are unsuitable for each other
	➤ Incorrect DIP switch current settings
	➤ Incorrect wirings among the motor, driver, and power supply
	➤ Short circuit exists





12. Appendix











I. The 3rd Generation TB6560 Driver Sets Categories

3 rd Generation TB6560 Drivers	Models	Contains	Main Functions
Standard Models	TB3-S	3 Axis Driver	➤ Intelligently Control Motors Via PC
	TB3CD-S	3 Axis Driver + Control Pad + Display Panel	➤ Intelligently Control Motors Via PC ➤ Manually Control Motors Via Control Pad ➤ Intelligently Switch PC & Control Pad ➤ Synchronously display the Moving coordinate in software ➤ Real-time Display the moving path of motors
	TB4-S	4 Axis Driver	➤ Intelligently Control Motors Via PC
	TB4CD-S	4 Axis Driver + Control Pad + Display Panel	➤ Intelligently Control Motors Via PC ➤ Manually Control Motors Via Control Pad ➤ Intelligently Switch PC & Control Pad ➤ Synchronously display the Moving coordinate in software ➤ Real-time Display the moving path of motors
	TB3-S(Box)	3 Axis Driver (Box)	➤ Intelligently Control Motors Via PC ➤ Aluminum Box Protection
	TB4-S(Box)	4 Axis Driver (Box)	➤ Intelligently Control Motors Via PC ➤ Aluminum Box Protection
	TB3C-S(Box)	3 Axis Driver + Control Pad (Box)	➤ Intelligently Control Motors Via PC ➤ Manually Control Motors via Control Pad ➤ Intelligently Switch PC & Control Pad ➤ Aluminum Box Protection
	TB4C-S(Box)	4 Axis Driver + Control Pad (Box)	➤ Intelligently Control Motors Via PC ➤ Manually Control Motors Via Control Pad ➤ Intelligently Switch PC & Control Pad ➤ Aluminum Box Protection
	TB3CD-S(Box)	3 Axis Driver + Control Pad + Display Panel (Box)	➤ Intelligently Control Motors Via PC ➤ Manually Control Motors Via Control Pad ➤ Intelligently Switch PC & Control Pad ➤ Synchronously display the Moving coordinate in software ➤ Real-time Display the moving path of motors ➤ Aluminum Box Protection
	TB4CD-S(Box)	4 Axis Driver + Control Pad + Display Panel (Box)	➤ Intelligently Control Motors Via PC ➤ Manually Control Motors Via Control Pad ➤ Intelligently Switch PC & Control Pad ➤ Synchronously display the Moving coordinate in software ➤ Real-time Display the moving path of motors ➤ Aluminum Box Protection

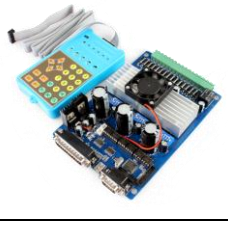
Professional Models	TB3-P	3 Axis DriverⓈ	➤ Intelligently Control Motors Via PC
	TB3CD-P	3 Axis DriverⓈ + Control PadⓈ + Display Panel	<ul style="list-style-type: none"> ➤ Intelligently Control Motors Via PC ➤ Manually Control Motors Via Control Pad ➤ Intelligently Switch PC & Control Pad ➤ Synchronously display the Moving coordinate in software ➤ Real-time Display the moving path of motors ➤ Record G-Code from PC and run it without PC ➤ Manually Program and run it to control Motors
	TB4-P	3 Axis DriverⓈ	➤ Intelligently Control Motors Via PC
	TB4CD-P	4 Axis DriverⓈ + Control PadⓈ + Display Panel	<ul style="list-style-type: none"> ➤ Intelligently Control Motors Via PC ➤ Control Motors Via Control Pad ➤ Intelligently Switch PC & Control Pad ➤ Synchronously display the Moving coordinate in software ➤ Real-time Display the moving path of motors ➤ Record G-Code from PC and run it without PC ➤ Manually Program and run it to control Motors
	TB3-P(Box)	3 Axis DriverⓈ (Box)	<ul style="list-style-type: none"> ➤ Intelligently Control Motors Via PC ➤ Aluminum Box Protection
	TB4-P(Box)	4 Axis DriverⓈ (Box)	<ul style="list-style-type: none"> ➤ Intelligently Control Motors Via PC ➤ Aluminum Box Protection
	TB3C-P(Box)	3 Axis DriverⓈ + Control PadⓈ (Box)	<ul style="list-style-type: none"> ➤ Intelligently Control Motors Via PC ➤ Manually Control Motors via Control Pad ➤ Intelligently Switch PC & Control Pad ➤ Aluminum Box Protection
	TB4C-P(Box)	4 Axis DriverⓈ + Control PadⓈ (Box)	<ul style="list-style-type: none"> ➤ Intelligently Control Motors Via PC ➤ Manually Control Motors via Control Pad ➤ Intelligently Switch PC & Control Pad ➤ Aluminum Box Protection
	TB3CD-P(Box)	3 Axis DriverⓈ + Control PadⓈ + Display Panel (Box)	<ul style="list-style-type: none"> ➤ Intelligently Control Motors Via PC ➤ Manually Control Motors Via Control Pad ➤ Intelligently Switch PC & Control Pad ➤ Synchronously display the Moving coordinate in software ➤ Real-time Display the moving path of motors ➤ Record G-Code from PC and run it without PC ➤ Manually Program and run it to control Motors ➤ Aluminum Box Protection
	TB4CD-P(Box)	4 Axis DriverⓈ + Control PadⓈ + Display Panel (Box)	<ul style="list-style-type: none"> ➤ Intelligently Control Motors Via PC ➤ Manually Control Motors Via Control Pad ➤ Intelligently Switch PC & Control Pad ➤ Synchronously display the Moving coordinate in software ➤ Real-time Display the moving path of motors ➤ Record G-Code from PC and run it without PC ➤ Manually Program and run it to control Motors ➤ Aluminum Box Protection

II. The 3rd Generation TB6560 Driver Set Details

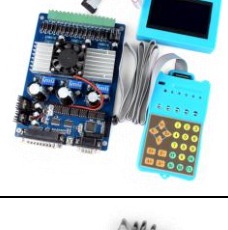
3 rd Generation TB6560 Drivers	Models	Contains & Pictures	Models	Contains & Pictures
Standard Models	TB3-S		TB3-S(Box)	
	TB4-S		TB4-S(Box)	
	TB3C-S		TB3C-S(Box)	
	TB4C-S		TB4C-S(Box)	
	TB3CD-S		TB3CD-S(Box)	
	TB4CD-S		TB4CD-S(Box)	

Professional Models	TB3-P		TB3-P(Box)	
	TB4-P		TB4-P(Box)	
	TB3C-P		TB3C-P(Box)	
	TB4C-P		TB4C-P(Box)	
	TB3CD-P		TB3CD-P(Box)	
	TB4CD-P		TB4CD-P(Box)	