

YUHAI

SG-AS Series AC Servo Drive

**SERVOPACK with  
Analog Voltage/Pulse Train References  
Product Manual**

Model: SG-AS□□□□



# Using This Manual

## ◆ Technical Terms Used in This Manual

The following terms are used in this manual.

Term	Meaning
Servomotor	SY-Series Rotary Servomotor
Rotary Servomotor	A generic term used for a SG-AS Series Rotary Servomotor ( 60SY,80SY,90SY,110SY,130SY,180SY).
SERVOPACK	SG Series SG-AS Servo Amplifier with Analog Voltage/Pulse Train References.
Servo Drive	The combination of a Servomotor and SERVOPACK.
Servo System	A servo control system that includes the combination of a Servo Drive with a host controller and peripheral devices.
servo ON	Supplying power to the motor.
servo OFF	Not supplying power to the motor.
base block (BB)	Shutting OFF the power supply to the motor by shutting OFF the base current to the power transistor in the SERVOPACK.
servo lock	A state in which the motor is stopped and is in a position loop with a position reference of 0.
Main Circuit Cable	One of the cables that connect to the main circuit terminals, including the Main Circuit Power Supply Cable, Control Power Supply Cable, and Servomotor Main Circuit Cable.

## ◆ Notation Used in this Manual

### ■ Notation for Reverse Signals

The names of reverse signals (i.e., ones that are valid when low) are written with a forward slash (/) before the signal abbreviation.

Notation Example

$\overline{BK}$  is written as /BK.

### ■ Notation for Parameters

The notation depends on whether the parameter requires a numeric setting (parameter for numeric setting) or requires the selection of a function (parameter for selecting functions).

#### • Parameters for Numeric Settings

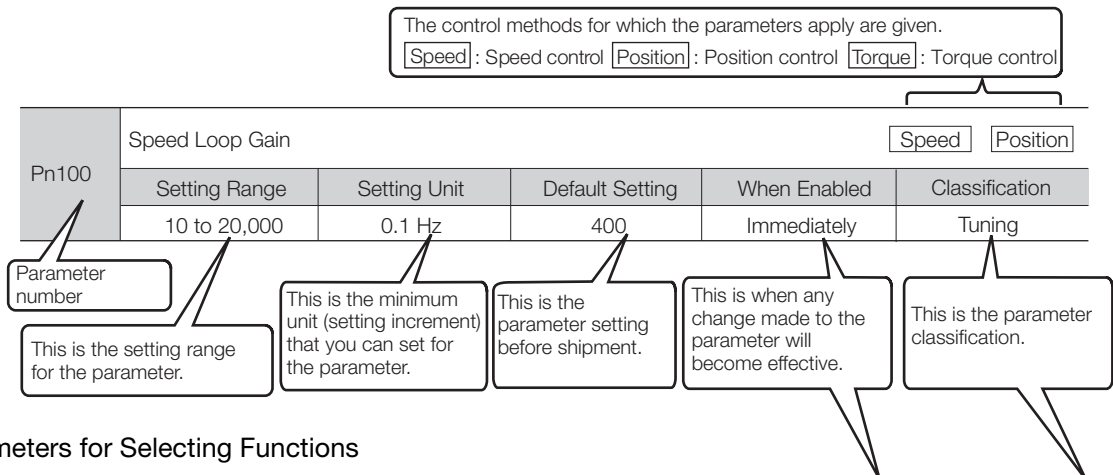

#### • Parameters for Selecting Functions

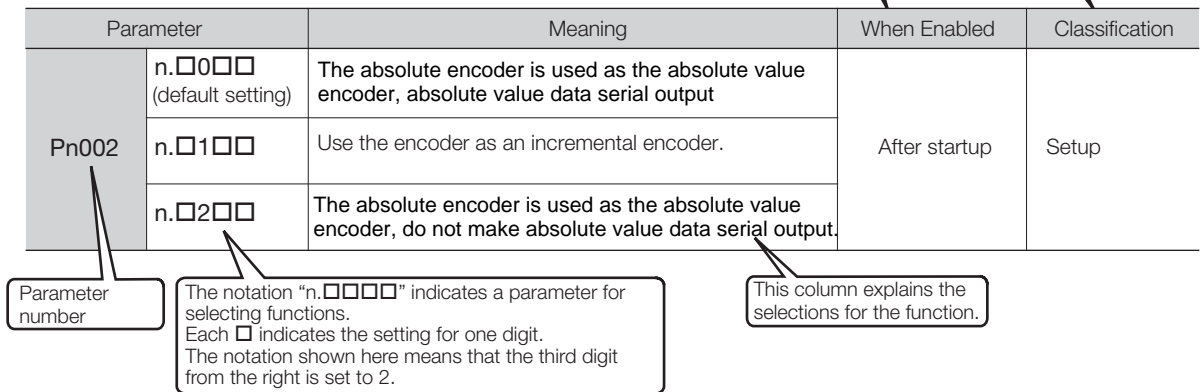

Notation Example

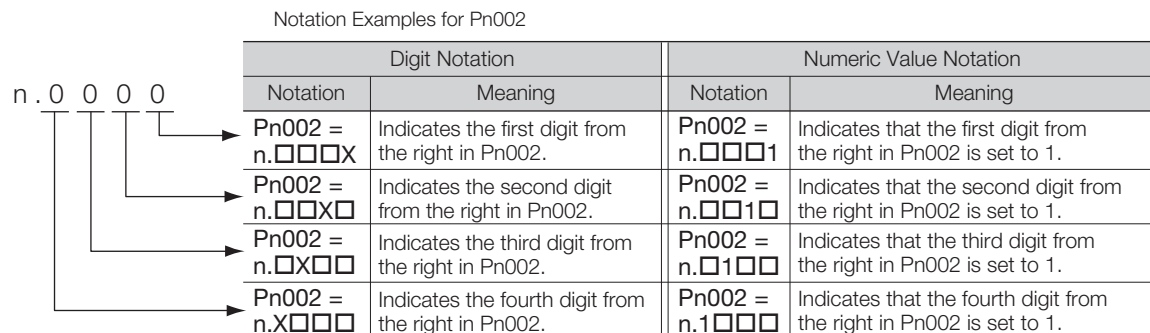

---

## ◆ Visual Aids

The following aids are used to indicate certain types of information for easier reference.



Indicates precautions or restrictions that must be observed.  
Also indicates alarm displays and other precautions that will not result in machine damage.



Indicates definitions of difficult terms or terms that have not been previously explained in this manual.

**Example**

Indicates operating or setting examples.

**Information**

Indicates supplemental information to deepen understanding or useful information.

---

# Safety Precautions

## ◆ Safety Information

To prevent personal injury and equipment damage in advance, the following signal words are used to indicate safety precautions in this document. The signal words are used to classify the hazards and the degree of damage or injury that may occur if a product is used incorrectly. Information marked as shown below is important for safety. Always read this information and heed the precautions that are provided.



### DANGER

- Indicates precautions that, if not heeded, are likely to result in loss of life, serious injury, or fire.



### WARNING

- Indicates precautions that, if not heeded, could result in loss of life, serious injury, or fire.



### CAUTION

- Indicates precautions that, if not heeded, could result in relatively serious or minor injury, or in fire.

### NOTICE

- Indicates precautions that, if not heeded, could result in property damage.

---

## ◆ Safety Precautions That Must Always Be Observed

### ■ General Precautions



## DANGER

- Read and understand this manual to ensure the safe usage of the product.
- Keep this manual in a safe, convenient place so that it can be referred to whenever necessary. Make sure that it is delivered to the final user of the product.
- Do not remove covers, cables, connectors, or optional devices while power is being supplied to the SERVOPACK.  
There is a risk of electric shock, operational failure of the product, or burning.



## WARNING

- Use a power supply with specifications (number of phases, voltage, frequency, and AC type) that are appropriate for the product.  
There is a risk of burning, electric shock, or fire.
- Connect the ground terminals on the SERVOPACK and Servomotor to ground poles according to local electrical codes (100  $\Omega$  or less for a SERVOPACK with a 220-VAC power supply, and 10  $\Omega$  or less for a SERVOPACK with a 380-VAC power supply).  
There is a risk of electric shock or fire.
- Do not attempt to disassemble, repair, or modify the product.  
There is a risk of fire or failure.  
The warranty is void for the product if you disassemble, repair, or modify it.



## CAUTION

- The SERVOPACK heat sinks, regenerative resistors, External Dynamic Brake Resistors, Servomotors, and other components can be very hot while power is ON or soon after the power is turned OFF. Implement safety measures, such as installing covers, so that hands and parts such as cables do not come into contact with hot components.  
There is a risk of burn injury.
- For a 24-VDC power supply, use a power supply device with double insulation or reinforced insulation.  
There is a risk of electric shock.
- Do not damage, pull on, apply excessive force to, place heavy objects on, or pinch cables.  
There is a risk of failure, damage, or electric shock.
- Do not use the product in an environment that is subject to water, corrosive gases, or flammable gases, or near flammable materials.  
There is a risk of electric shock or fire.

## NOTICE

- Do not attempt to use a SERVOPACK or Servomotor that is damaged or that has missing parts.
- Install external emergency stop circuits that shut OFF the power supply and stops operation immediately when an error occurs.
- In locations with poor power supply conditions, install the necessary protective devices (such as AC reactors) to ensure that the input power is supplied within the specified voltage range. There is a risk of damage to the SERVOPACK.
- Use a Noise Filter to minimize the effects of electromagnetic interference. Electronic devices used near the SERVOPACK may be affected by electromagnetic interference.
- Always use a Servomotor and SERVOPACK in one of the specified combinations.
- Do not touch a SERVOPACK or Servomotor with wet hands. There is a risk of product failure.

### ■ Storage Precautions

## CAUTION

- Do not place an excessive load on the product during storage. (Follow all instructions on the packages.) There is a risk of injury or damage.

## NOTICE

- Do not install or store the product in any of the following locations.
  - Locations that are subject to direct sunlight
  - Locations that are subject to ambient temperatures that exceed product specifications
  - Locations that are subject to relative humidities that exceed product specifications
  - Locations that are subject to condensation as the result of extreme changes in temperature
  - Locations that are subject to corrosive or flammable gases
  - Locations that are near flammable materials
  - Locations that are subject to dust, salts, or iron powder
  - Locations that are subject to water, oil, or chemicals
  - Locations that are subject to vibration or shock that exceeds product specifications
  - Locations that are subject to radiationIf you store or install the product in any of the above locations, the product may fail or be damaged.

### ■ Transportation Precautions

## CAUTION

- Transport the product in a way that is suitable to the mass of the product.
- Do not use the eyebolts on a SERVOPACK or Servomotor to move the machine. There is a risk of damage or injury.
- When you handle a SERVOPACK or Servomotor, be careful of sharp parts, such as the corners. There is a risk of injury.
- Do not place an excessive load on the product during transportation. (Follow all instructions on the packages.) There is a risk of injury or damage.

## NOTICE

- Do not hold onto the front cover or connectors when you move a SERVOPACK.  
There is a risk of the SERVOPACK falling.
- A SERVOPACK or Servomotor is a precision device. Do not drop it or subject it to strong shock.  
There is a risk of failure or damage.
- Do not subject connectors to shock.  
There is a risk of faulty connections or damage.
- If disinfectants or insecticides must be used to treat packing materials such as wooden frames, plywood, or pallets, the packing materials must be treated before the product is packaged, and methods other than fumigation must be used.  
Example: Heat treatment, where materials are kiln-dried to a core temperature of 56°C for 30 minutes or more.  
If the electronic products, which include stand-alone products and products installed in machines, are packed with fumigated wooden materials, the electrical components may be greatly damaged by the gases or fumes resulting from the fumigation process. In particular, disinfectants containing halogen, which includes chlorine, fluorine, bromine, or iodine can contribute to the erosion of the capacitors.
- Do not overtighten the eyebolts on a SERVOPACK or Servomotor.  
If you use a tool to overtighten the eyebolts, the tapped holes may be damaged.

### ■ Installation Precautions



## CAUTION

- Install the Servomotor or SERVOPACK in a way that will support the mass given in technical documents.
- Install SERVOPACKs, Servomotors, regenerative resistors, and External Dynamic Brake Resistors on nonflammable materials.  
Installation directly onto or near flammable materials may result in fire.
- Provide the specified clearances between the SERVOPACK and the control panel as well as with other devices.  
There is a risk of fire or failure.
- Install the SERVOPACK in the specified orientation.  
There is a risk of fire or failure.
- Do not step on or place a heavy object on the product.  
There is a risk of failure, damage, or injury.
- Do not allow any foreign matter to enter the SERVOPACK or Servomotor.  
There is a risk of failure or fire.

## NOTICE

- **Do not install or store the product in any of the following locations.**
  - Locations that are subject to direct sunlight
  - Locations that are subject to ambient temperatures that exceed product specifications
  - Locations that are subject to relative humidities that exceed product specifications
  - Locations that are subject to condensation as the result of extreme changes in temperature
  - Locations that are subject to corrosive or flammable gases
  - Locations that are near flammable materials
  - Locations that are subject to dust, salts, or iron powder
  - Locations that are subject to water, oil, or chemicals
  - Locations that are subject to vibration or shock that exceeds product specifications
  - Locations that are subject to radiationIf you store or install the product in any of the above locations, the product may fail or be damaged.
- **Use the product in an environment that is appropriate for the product specifications.**

If you use the product in an environment that exceeds product specifications, the product may fail or be damaged.
- **A SERVOPACK or Servomotor is a precision device. Do not drop it or subject it to strong shock.**

There is a risk of failure or damage.
- **Always install a SERVOPACK in a control panel.**
- **Do not allow any foreign matter to enter a SERVOPACK or a Servomotor with a Cooling Fan and do not cover the outlet from the Servomotor's cooling fan.**

There is a risk of failure.

### ■ Wiring Precautions



## DANGER

- **Do not change any wiring while power is being supplied.**

There is a risk of electric shock or injury.



## WARNING

- **Wiring and inspections must be performed only by qualified engineers.**

There is a risk of electric shock or product failure.
- **Check all wiring and power supplies carefully.**

Incorrect wiring or incorrect voltage application to the output circuits may cause short-circuit failures. If a short-circuit failure occurs as a result of any of these causes, the holding brake will not work. This could damage the machine or cause an accident that may result in death or injury.
- **Connect the AC power supplies to the specified SERVOPACK terminals.**
  - Connect an AC power supply to the L1, L2, and L3 terminals and the L1C and L2C terminals on the SERVOPACK.

There is a risk of failure or fire.
- **If you use a SERVOPACK with the Dynamic Brake Hardware Option, connect an External Dynamic Brake Resistor that is suitable for the machine and equipment specifications to the specified terminals.**

There is a risk of unexpected operation, machine damage, burning, or injury when an emergency stop is performed.



## CAUTION

- Wait for at least six minutes after turning OFF the power supply (with a SERVOPACK for a 100-VAC input, wait for at least nine minutes) and then make sure that the CHARGE indicator is not lit before starting wiring or inspection work. Do not touch the power supply terminals while the CHARGE lamp is lit after turning OFF the power supply because high voltage may still remain in the SERVOPACK.  
There is a risk of electric shock.
- Observe the precautions and instructions for wiring and trial operation precisely as described in this document.  
Failures caused by incorrect wiring or incorrect voltage application in the brake circuit may cause the SERVOPACK to fail, damage the equipment, or cause an accident resulting in death or injury.
- Check the wiring to be sure it has been performed correctly.  
Connectors and pin layouts are sometimes different for different models. Always confirm the pin layouts in technical documents for your model before operation.  
There is a risk of failure or malfunction.
- Connect wires to power supply terminals and motor connection terminals securely with the specified methods and tightening torque.  
Insufficient tightening may cause wires and terminal blocks to generate heat due to faulty contact, possibly resulting in fire.
- Use shielded twisted-pair cables or screened unshielded multi-twisted-pair cables for I/O Signal Cables and Encoder Cables.
- Observe the following precautions when wiring the SERVOPACK's main circuit terminals.
  - Turn ON the power supply to the SERVOPACK only after all wiring, including the main circuit terminals, has been completed.
  - If a connector is used for the main circuit terminals, remove the main circuit connector from the SERVOPACK before you wire it.
  - Insert only one wire per insertion hole in the main circuit terminals.
  - When you insert a wire, make sure that the conductor wire (e.g., whiskers) does not come into contact with adjacent wires.
- Install molded-case circuit breakers and other safety measures to provide protection against short circuits in external wiring.  
There is a risk of fire or failure.

## NOTICE

- Whenever possible, use the Cables specified by Yaskawa.  
If you use any other cables, confirm the rated current and application environment of your model and use the wiring materials specified by Yaskawa or equivalent materials.
- Securely tighten cable connector screws and lock mechanisms.  
Insufficient tightening may result in cable connectors falling off during operation.
- Do not bundle power lines (e.g., the Main Circuit Cable) and low-current lines (e.g., the I/O Signal Cables or Encoder Cables) together or run them through the same duct. If you do not place power lines and low-current lines in separate ducts, separate them by at least 30 cm.  
If the cables are too close to each other, malfunctions may occur due to noise affecting the low-current lines.
- Install a battery at either the host controller or on the Encoder Cable.  
If you install batteries both at the host controller and on the Encoder Cable at the same time, you will create a loop circuit between the batteries, resulting in a risk of damage or burning.
- When connecting a battery, connect the polarity correctly.  
There is a risk of battery rupture or encoder failure.

## ■ Operation Precautions



### WARNING

- Before starting operation with a machine connected, change the settings of the switches and parameters to match the machine.  
Unexpected machine operation, failure, or personal injury may occur if operation is started before appropriate settings are made.
- Do not radically change the settings of the parameters.  
There is a risk of unstable operation, machine damage, or injury.
- Install limit switches or stoppers at the ends of the moving parts of the machine to prevent unexpected accidents.  
There is a risk of machine damage or injury.
- For trial operation, securely mount the Servomotor and disconnect it from the machine.  
There is a risk of injury.
- Forcing the motor to stop for overtravel is disabled when the Jog (Fn002), utility function is executed. Take necessary precautions.  
There is a risk of machine damage or injury.
- When an alarm occurs, the Servomotor will coast to a stop or stop with the dynamic brake according to the SERVOPACK Option and settings. The coasting distance will change with the moment of inertia of the load and the resistance of the External Dynamic Brake Resistor. Check the coasting distance during trial operation and implement suitable safety measures on the machine.
- Do not enter the machine's range of motion during operation.  
There is a risk of injury.
- Do not touch the moving parts of the Servomotor or machine during operation.  
There is a risk of injury.



### CAUTION

- Design the system to ensure safety even when problems, such as broken signal lines, occur. For example, the P-OT and N-OT signals are set in the default settings to operate on the safe side if a signal line breaks. Do not change the polarity of this type of signal.
- When overtravel occurs, the power supply to the motor is turned OFF and the brake is released. If you use the Servomotor to drive a vertical load, set the Servomotor to enter a zero-clamped state after the Servomotor stops. Also, install safety devices (such as an external brake or counterweight) to prevent the moving parts of the machine from falling.
- Always turn OFF the servo before you turn OFF the power supply. If you turn OFF the main circuit power supply or control power supply during operation before you turn OFF the servo, the Servomotor will stop as follows:
  - If you turn OFF the main circuit power supply during operation without turning OFF the servo, the Servomotor will stop abruptly with the dynamic brake.
  - If you turn OFF the control power supply without turning OFF the servo, the stopping method that is used by the Servomotor depends on the model of the SERVOPACK. For details, refer to the manual for the SERVOPACK.
  - If you use a SERVOPACK with the Dynamic Brake Hardware Option, the Servomotor stopping methods will be different from the stopping methods used without the Option or with other Hardware Options. For details, refer to the *Σ-7-Series AC Servo Drive Σ-7S/Σ-7W SERVOPACK with Dynamic Brake Hardware Option Specifications Product Manual*.
- Do not use the dynamic brake for any application other than an emergency stop.  
There is a risk of failure due to rapid deterioration of elements in the SERVOPACK and the risk of unexpected operation, machine damage, burning, or injury.

## NOTICE

- When you adjust the gain during system commissioning, use a measuring instrument to monitor the torque waveform and speed waveform and confirm that there is no vibration. If a high gain causes vibration, the Servomotor will be damaged quickly.
- Do not frequently turn the power supply ON and OFF. After you have started actual operation, allow at least one hour between turning the power supply ON and OFF (as a guideline). Do not use the product in applications that require the power supply to be turned ON and OFF frequently. The elements in the SERVOPACK will deteriorate quickly.

### ■ Maintenance and Inspection Precautions



## DANGER

- Do not change any wiring while power is being supplied. There is a risk of electric shock or injury.



## WARNING

- Wiring and inspections must be performed only by qualified engineers. There is a risk of electric shock or product failure.



## CAUTION

- Wait for at least six minutes after turning OFF the power supply (with a SERVOPACK for a 100-VAC input, wait for at least nine minutes) and then make sure that the CHARGE indicator is not lit before starting wiring or inspection work. Do not touch the power supply terminals while the CHARGE lamp is lit after turning OFF the power supply because high voltage may still remain in the SERVOPACK. There is a risk of electric shock.
- Before you replace a SERVOPACK, back up the settings of the SERVOPACK parameters. Copy the backed up parameter settings to the new SERVOPACK and confirm that they were copied correctly. If you do not copy backed up parameter settings or if the copy operation is not completed normally, normal operation may not be possible, possibly resulting in machine or equipment damage.

## NOTICE

- Discharge all static electricity from your body before you operate any of the buttons or switches inside the front cover of the SERVOPACK. There is a risk of equipment damage.

## ■ Troubleshooting Precautions



### DANGER

- If the safety device (molded-case circuit breaker or fuse) installed in the power supply line operates, remove the cause before you supply power to the SERVOPACK again. If necessary, repair or replace the SERVOPACK, check the wiring, and remove the factor that caused the safety device to operate.  
There is a risk of fire, electric shock, or injury.



### WARNING

- The product may suddenly start to operate when the power supply is recovered after a momentary power interruption. Design the machine to ensure human safety when operation restarts.  
There is a risk of injury.



### CAUTION

- When an alarm occurs, remove the cause of the alarm and ensure safety. Then reset the alarm or turn the power supply OFF and ON again to restart operation.  
There is a risk of injury or machine damage.
- If the Servo ON signal is input to the SERVOPACK and an alarm is reset, the Servomotor may suddenly restart operation. Confirm that the servo is OFF and ensure safety before you reset an alarm.  
There is a risk of injury or machine damage.
- Always insert a magnetic contactor in the line between the main circuit power supply and the main circuit power supply terminals on the SERVOPACK so that the power supply can be shut OFF at the main circuit power supply.  
If a magnetic contactor is not connected when the SERVOPACK fails, a large current may flow, possibly resulting in fire.
- If an alarm occurs, shut OFF the main circuit power supply.  
There is a risk of fire due to a regenerative resistor overheating as the result of regenerative transistor failure.
- Install a ground fault detector against overloads and short-circuiting or install a molded-case circuit breaker combined with a ground fault detector.  
There is a risk of SERVOPACK failure or fire if a ground fault occurs.
- The holding brake on a Servomotor will not ensure safety if there is the possibility that an external force (including gravity) may move the current position and create a hazardous situation when power is interrupted or an error occurs. If an external force may cause movement, install an external braking mechanism that ensures safety.

## ■ Disposal Precautions

- When disposing of the product, treat it as ordinary industrial waste. However, local ordinances and national laws must be observed. Implement all labeling and warnings as a final product as required.

---

## ■ General Precautions

- Figures provided in this document are typical examples or conceptual representations. There may be differences between them and actual wiring, circuits, and products.
- The products shown in illustrations in this document are sometimes shown without covers or protective guards. Always replace all covers and protective guards before you use the product.
- If you need a new copy of this document because it has been lost or damaged, contact your nearest YUHAI representative or one of the offices listed on the back of this document.
- This document is subject to change without notice for product improvements, specifications changes, and improvements to the manual itself.  
We will update the document number of the document and issue revisions when changes are made.
- Any and all quality guarantees provided by YUHAI are null and void if the customer modifies the product in any way. YUHAI disavows any responsibility for damages or losses that are caused by modified products.

---

# Contents

About this Manual .....	iii
Outline of Manual .....	iii
Related Documents .....	iv
Using This Manual .....	viii
Safety Precautions .....	xi
Warranty .....	xxi
Compliance with UL Standards, EU Directives, and Other Safety Standards. . .	xxiii

## 1

### Basic Information on SERVOPACKs

---

<b>1.1</b>	<b>The SG Series .....</b>	<b>1-2</b>
<b>1.2</b>	<b>Part Names .....</b>	<b>1-3</b>
<b>1.3</b>	<b>Model Designations .....</b>	<b>1-3</b>
<b>1.4</b>	<b>SERVOPACK Overload Protection Characteristics .....</b>	<b>1-4</b>
<b>1.5</b>	<b>Specifications .....</b>	<b>1-5</b>
<b>1.6</b>	<b>External Dimensions .....</b>	<b>1-9</b>

## 2

### SERVOPACK Installation

---

<b>2.1</b>	<b>Installation Precautions .....</b>	<b>2-2</b>
<b>2.2</b>	<b>Mounting Types and Orientation .....</b>	<b>2-3</b>
<b>2.3</b>	<b>Mounting Interval .....</b>	<b>2-5</b>
2.3.1	Installing One SERVOPACK in a Control Panel .....	2-5
2.3.2	Installing More Than One SERVOPACK in a Control Panel .....	2-5
<b>2.4</b>	<b>Derating Specifications .....</b>	<b>2-6</b>

# 3

## Wiring and Connecting SERVOPACKS

<b>3.1</b>	<b>Wiring and Connecting SERVOPACKs . . . . .</b>	<b>3-1</b>
3.1.1	General Precautions . . . . .	3-2
3.1.2	Countermeasures against Noise . . . . .	3-3
3.1.3	Grounding . . . . .	3-6
<b>3.2</b>	<b>Basic Wiring Diagrams . . . . .</b>	<b>3-7</b>
<b>3.3</b>	<b>Wiring the Power Supply to the SERV OPACK . . . . .</b>	<b>3-8</b>
3.3.1	Terminal Symbols and Terminal Names . . . . .	3-8
<b>3.4</b>	<b>Wiring Servomotors . . . . .</b>	<b>3-9</b>
3.4.1	Terminal Symbols and Terminal Names . . . . .	3-9
3.4.2	Pin Arrangement of Encoder Connector (CN4) . . . . .	3-9
3.4.3	Wiring the SERVOPACK to the Holding Brake . . . . .	3-10
<b>3.5</b>	<b>I/O Signal Connections . . . . .</b>	<b>3-11</b>
3.5.1	I/O Signal Connector (CN3) Names and Functions . . . . .	3-11
3.5.2	I/O Signal Wiring Examples . . . . .	3-13
3.5.3	I/O Circuits . . . . .	3-16

# 4

## Basic Functions That Require Setting before Operation

<b>4.1</b>	<b>Manipulating Parameters (Pn□□□). . . . .</b>	<b>4-2</b>
4.1.1	Notation for Parameters . . . . .	4-2
4.1.2	Initializing Parameter Settings . . . . .	4-3
<b>4.2</b>	<b>Control Method Selection . . . . .</b>	<b>4-4</b>
<b>4.3</b>	<b>Automatic Detection of Connected Motor . . . . .</b>	<b>4-5</b>
<b>4.4</b>	<b>Functions and Settings for the /S-ON (Servo ON ) Signal . . . . .</b>	<b>4-6</b>
4.4.1	Function of the /S-ON (Servo ON) Signal . . . . .	4-6
<b>4.5</b>	<b>Motor Direction Setting . . . . .</b>	<b>4-7</b>
<b>4.6</b>	<b>Overtravel and Related Settings . . . . .</b>	<b>4-8</b>
4.6.1	Overtravel Signals . . . . .	4-8
4.6.2	Setting to Enable/Disable Overtravel . . . . .	4-8
<b>4.7</b>	<b>Holding Brake. . . . .</b>	<b>4-9</b>
4.7.1	Brake Operating Sequence . . . . .	4-9
4.7.2	/BK (Brake) Signal . . . . .	4-10
4.7.3	Output Timing of /BK (Brake) Signal When the Servomotor Is Stopped. . . . .	4-10
4.7.4	Output Timing of /BK (Brake) Signal When the Servomotor Is Operating. . . . .	4-11

<b>4.8</b>	<b>Motor Stopping Methods for Servo OFF and Alarms. . . . .</b>	<b>4-12</b>
<b>4.9</b>	<b>Electronic Gear Settings . . . . .</b>	<b>4-13</b>
4.9.1	Electronic Gear Ratio Settings. . . . .	4-13
4.9.2	Electronic Gear Ratio Setting Examples . . . . .	4-14
<b>4.10</b>	<b>Resetting the Absolute Encoder . . . . .</b>	<b>4-15</b>
4.10.1	Precautions on Resetting. . . . .	4-15
4.10.2	Preparations . . . . .	4-15
4.10.3	Applicable Tools . . . . .	4-15

## 5 Maintenance

<b>5.1</b>	<b>Inspections and Part Replacement . . . . .</b>	<b>5-2</b>
5.1.1	Inspections . . . . .	5-2
5.1.2	Guidelines for Part Replacement. . . . .	5-2
5.1.3	Replacing the Battery . . . . .	5-3
<b>5.2</b>	<b>Alarm Displays . . . . .</b>	<b>5-4</b>
5.2.1	List of Alarms . . . . .	5-4
5.2.2	Troubleshooting Alarms. . . . .	5-5
5.2.3	Resetting Alarms . . . . .	5-10
5.2.4	Displaying the Alarm History . . . . .	5-10
<b>5.3</b>	<b>Troubleshooting Based on the Operation and Conditions of the Servomotor. .</b>	<b>5-11</b>

## 6 Panel Displays and Panel Operator Procedures

<b>6.1</b>	<b>Panel Operator . . . . .</b>	<b>6-2</b>
6.1.1	Panel Operator Key Names and Functions . . . . .	6-2
6.1.2	Changing Modes . . . . .	6-2
6.1.3	Status Displays . . . . .	6-3
<b>6.2</b>	<b>Parameter (Pn□□□) Operations on the Panel Operator . . . . .</b>	<b>6-4</b>
6.2.1	Setting Parameters That Require Numeric Settings. . . . .	6-4
6.2.2	Setting Parameters That Require Selection of Functions. . . . .	6-5
<b>6.3</b>	<b>Monitor Display (Un□□□) Operations on the Panel Operator . .</b>	<b>6-6</b>
6.3.1	Basic Monitor Display Operations . . . . .	6-6
6.3.2	Input Signal Monitor (Un005) . . . . .	6-7
6.3.3	Output Signal Monitor (Un006) . . . . .	6-8

---

**6.4 Utility Function (Fn□□□) Operations on the Panel Operator 6-9**

6.4.1	Display Alarm History (Fn000) . . . . .	6-9
6.4.2	Jog (Fn002) . . . . .	6-10
6.4.3	Initialize Parameters (Fn005) . . . . .	6-10
6.4.4	Autotune Analog (Speed/Torque) Reference Offset (Fn009) . . . . .	6-11
6.4.5	Manually Adjust Speed Reference Offset (Fn00A) . . . . .	6-11
6.4.6	Manually Adjust Torque Reference Offset (Fn00B) . . . . .	6-12
6.4.7	Display Servomotor Model (Fn011) . . . . .	6-12
6.4.8	Display Software Version (Fn012) . . . . .	6-13
6.4.9	Multiturn Limit Setting after Multiturn Limit Disagreement Alarm (Fn013) . .	6-13

**7**

**Parameter Lists**

---

**7.1 List of Parameters . . . . . 7-2**

7.1.1	Interpreting the Parameter Lists . . . . .	7-2
7.1.2	List of Parameters . . . . .	7-3

**8**

**Communication**

---

**8.1 Communication Wiring . . . . . 8-2**

**8.2 User Parameter . . . . . 8-2**

**8.3 MODBUS Communiation Protocol . . . . . 8-3**

**8.4 MODBUS Communiation Address . . . . . 8-10**

# Basic Information on SERVOPACKs

---



This chapter provides information required to select SERVOPACKs, such as SERVOPACK models and combinations with Servomotors.

<b>1.1</b>	<b>The SG-AS Series</b> . . . . .	<b>1-2</b>
<b>1.2</b>	<b>Part Names</b> . . . . .	<b>1-3</b>
<b>1.3</b>	<b>Model Designations</b> . . . . .	<b>1-3</b>
<b>1.4</b>	<b>SERVOPACK Overload Protection Characteristics...</b>	<b>1-4</b>
<b>1.5</b>	<b>Specifications</b> . . . . .	<b>1-5</b>
<b>1.6</b>	<b>External Dimensions</b> . . . . .	<b>1-9</b>

## 1.1

## SG Series

The SG series SERVOPACKs are designed for applications that require frequent high-speed and high-precision positioning. The SERVOPACK will make the most of machine performance in the shortest time possible, thus contributing to improving productivity.

The SG series SERVOPACKs include SG-AS SERVOPACKs for single-axis control and SG-AD SERVOPACKs for two-axis control.

# 1.2 Part Names

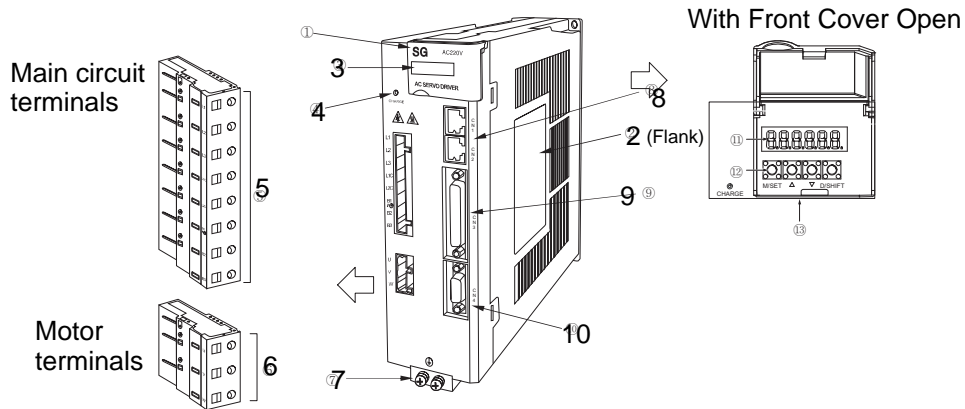

No.	Name	Description
①	Front Cover	-
②	Nameplate	Indicates the SERVOPACK model and ratings.
③	Input Voltage	-
4	CHARGE	Lit while the main circuit power is being supplied. Note: Even if you turn OFF the main circuit power supply, this indicator will be lit as long as the internal capacitor remains charged. Do not touch the main circuit or motor terminals while this indicator is lit. Doing so may result in electric shock.
5	Main Circuit Terminals	The terminals depend on the main circuit power supply input specifications of the SERVOPACK.
6	Servomotor Terminals (U,V,W)	The connection terminals for the Servomotor Main Circuit Cable (power line).
7	Ground Terminal (⊕)	The ground terminals to prevent electric shock. Always connect <b>this terminal</b> .
8	485 Communication connector(CN1,CN2)	
9	I/O Signal Connector(CN3)	Connects to reference input signals and sequence I/O signals.
10	Encoder Connector (CN4)	<ul style="list-style-type: none"> <li>Rotary Servomotor: Connects to the encoder in the Servomotor.</li> <li>Linear Servomotor: Connects to a Serial Converter Unit or linear encoder.</li> </ul>
11	Panel Display	Used to display SERVOPACK status, alarm numbers, and parameters.
12	Panel Operator Keys	Used to set parameters.
13	Panel Operator	-

## 1.3 Model Designations

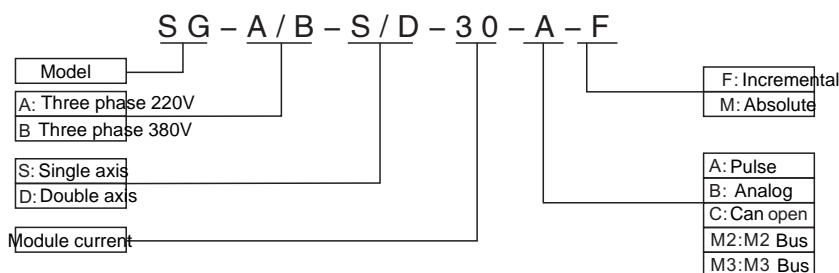

## 1.4

# SERVOPACK Overload Protection Characteristics

The overload detection level is set for hot start conditions with a SERVOPACK surrounding air temperature of 50°C.

An overload alarm (A.710 or A.720) will occur if overload operation that exceeds the overload protection characteristics shown in the following diagram (i.e., operation on the right side of the applicable line) is performed.

The actual overload detection level will be the detection level of the connected SERVOPACK or Servomotor that has the lower overload protection characteristics.

In most cases, that will be the overload protection characteristics of the Servomotor.

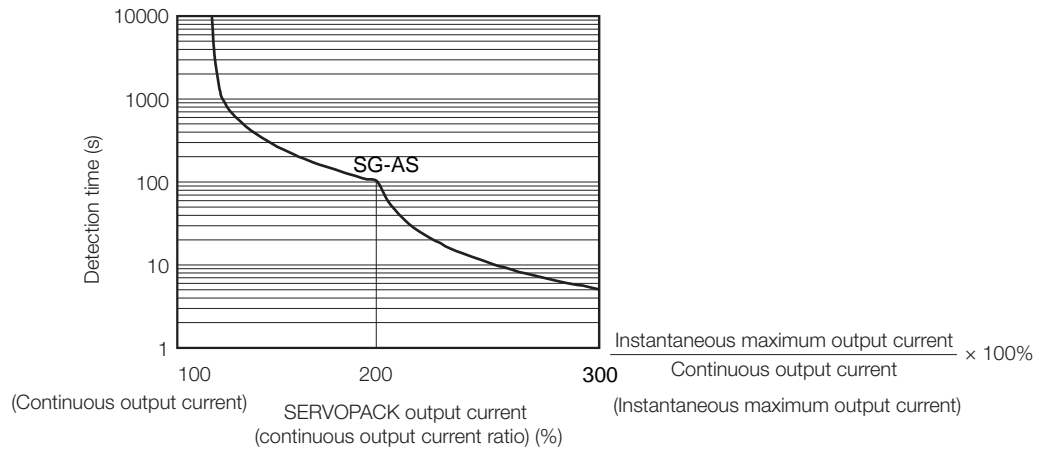

Note: The above overload protection characteristics do not mean that you can perform continuous duty operation with an output of 100% or higher. For a YUHAJ-specified combination of SERVOPACK and Servomotor, maintain the effective torque within the continuous duty zone of the torque-motor speed characteristic of the Servomotor.

## 1.5 Specification Table

Control mode		Position control, JOGGING, and so on.
Encoder feedback		Incremental encoder: 2500PPR Standard incremental type, 2500PPR Saving line incremental Serial encoder: 2 <sup>17</sup> bit Incremental encoder, 2 <sup>17</sup> /2 <sup>16</sup> bit Absolute encoder
Environmental Conditions	Surrounding Air Temperature/Storage Temperature	Surrounding Air Temperature: 0 <sup>+</sup> +50 <sup>+</sup> °C, Storage Humidity: -20 <sup>~</sup> +85 <sup>+</sup> °C
	Surrounding Air Temperature/Storage Humidity	90%RH relative humidity max. (with no freezing or condensation)
	Vibration Resistance/Shock Resistance	4.9m/s <sup>2</sup> /19.6m/s <sup>2</sup>
Structure		Base-mounted type
Performance	Speed Control Range	1:10000(At the rated torque, the lower limit of the speed control range must not cause the Servomotor to stop.)
	Speed response	1KHz
	Coefficient of Speed Fluctuation(Load change)	±0.01% of rated speed max. (for a load fluctuation of 0% to 100%)
	Coefficient of Speed Fluctuation(Voltage change)	Rated voltage ±10%; 0%(for rated speed)
Analog Speed Reference Input	Coefficient of Speed Fluctuation(Temperature change)	25±25°C:±0.1% of rated speed max.
	Reference Voltage	DC±10V
	Input Impedance	About 20KΩ
Analog Torque Reference Input	Circuit Time Constant	47μs
	Reference Voltage	DC±10V
	Input Impedance	About 20KΩ
Sequence Input Signals	Circuit Time Constant	47μs
	Number of input points	8 points
	Input Signals That Can Be Allocated	<ul style="list-style-type: none"> <li>• /S-ON (Servo ON) signal</li> <li>• /P-CON (Proportional Control) Signal</li> <li>• P-OT (Forward Drive Prohibit) and N-OT (Reverse Drive Prohibit) signals</li> <li>• /ALM-RST (Alarm Reset) signal</li> <li>• /P-CL (Forward External Torque Limit) and /N-CL (Reverse External Torque Limit) signals</li> <li>• /CLR Position Deviation Clear Signal</li> <li>• Internal Set Speed Selection Signal</li> </ul> <p>A signal can be allocated and the positive and negative logic can be changed.</p>
Sequence Output Signals	Number of output points	6 points
	Input Signals That Can Be Allocated	<ul style="list-style-type: none"> <li>• /ALM-RST (Alarm Reset) signal</li> <li>• /COIN (Positioning Completion) Signal</li> <li>• /V-CMP (Speed Coincidence Detection) Signal</li> <li>• /TGON (Rotation Detection) Signal</li> <li>• /S-RDY (Servo Ready) signal</li> <li>• /CLT (Torque Limit Detection) Signal</li> <li>• /BK (Brake) signal</li> <li>• PGC Encoder Zero output Signal</li> </ul> <p>A signal can be allocated and the positive and negative logic can be changed.</p>
	Encoder Divided Pulse Output	Phase A, phase B, phase C: Line-driver output Number of divided output pulses: Any setting is allowed.

RS-485 Communications	Communication Protocol	MODBUS
	r:N Communication	Up to N = 127 stations possible
	Axis Address Setting	Set with parameters.
CAN Communications	Communication Protocol	CANOpen (DS301 + DS402 guild regulations)
	r:N Communication	Up to N = 127 stations possible
	Axis Address Setting	Set with parameters.
Displays/Indicators		CHARGE indicator and five-digit seven-segment display
Regenerative Processing		Built-in regenerative resistor or external regenerative resistor (Selection)
Overtravel (OT) Prevention		Stopping with dynamic brake, deceleration to a stop, or coasting to a stop for the P-OT (Forward Drive Prohibit) or N-OT (Reverse Drive Prohibit) signal
Protective Functions		Overcurrent, overvoltage, low voltage, overload, overspeed, regeneration error, encoder feedback error etc.
Monitoring Functions		Speed, current position, reference pulse accumulate, position deviation, motor current, running station, I/O signal etc.
Utility Functions		Gain adjustment, alarm history, jogging, origin search, inertia detection, etc.
Intelligent function		Built-in gain auto-tuning function
Applicative loading inertia		Lower than motor inertia 5 times
Position Control	Feedback Compensation	0~100% ( Set Unit 1%)
	Input Pulse Type	Sign + pulse train, CW + CCW pulse trains, and two-phase pulse trains with 90° phase differential
	Input Pulse Form	Line driver or open collector
	Max. Input Pulse Frequency	<ul style="list-style-type: none"> <li>• Line Driver</li> <li>Sign + pulse train or CW + CCW pulse trains: 500K pps</li> <li>Two-phase(A phase and B phase) pulse trains with 90° phase differential: 500K pps</li> <li>• Open Collector</li> <li>Sign + pulse train or CW + CCW pulse trains: 200 kpps</li> <li>Two-phase(A phase and B phase) pulse trains with 90° phase differential: 200 kpps</li> </ul>

1.6 External Dimensions

1.6 External Dimensions

1.6 Servopack External Dimensions

Pedestal Type

Three phase AC 220V SG-AS15\*\*  
For 60mm motor

Current:15A

Output Power : 200W-750W

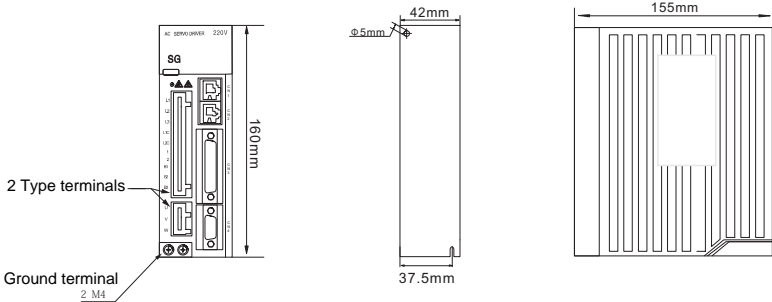

Three phase AC 220V SG-AS15\*\*  
For 80/90mm motor

Current:15A

Output Power : 750W-1000W

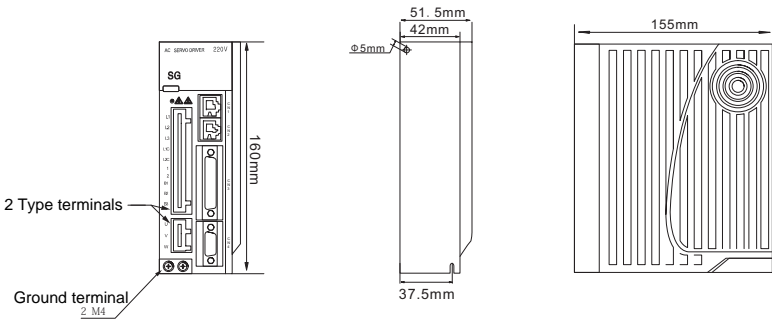

Three phase AC 220V SG-AS30\*\*

Current:30A

Output Power:1KW-2.6KW

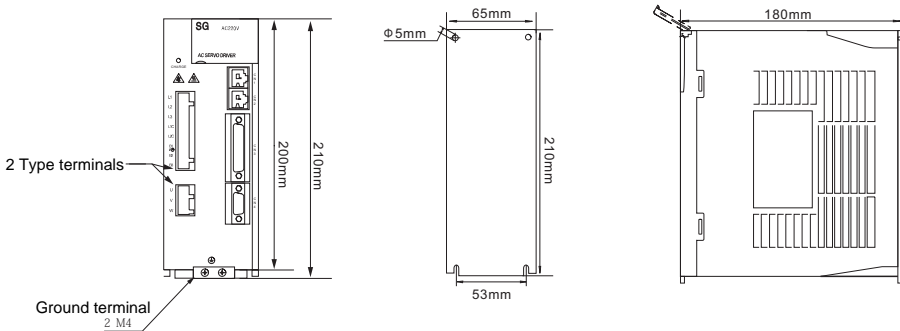

1.6 External Dimensions

Three phase AC 220V SG-AS50\*\* Current: 50A Output Power: 2.0KW-5KW  
 AC 220V SG-AS75 Current :75A Output power: 2KW-7.5KW

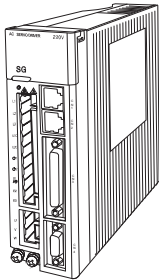
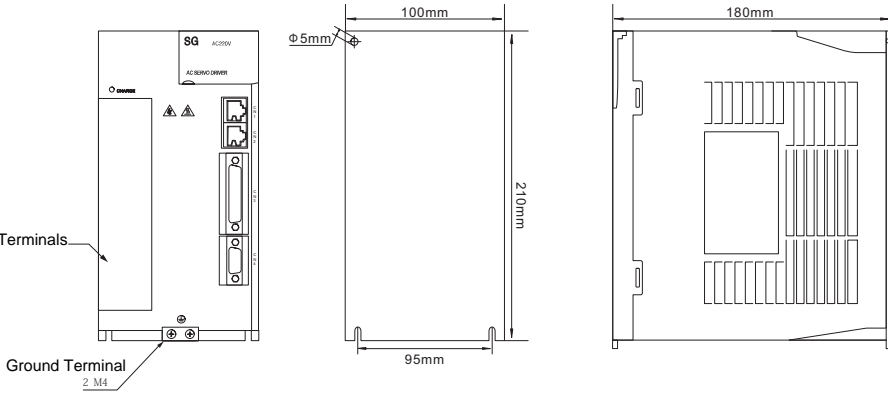

SG-AS15\*\* Current: 15A  
 Output Power: 200W-750W

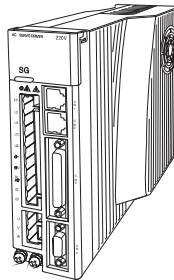

SG-AS15\*\* Current: 15A  
 Output Power: 750W-1KW

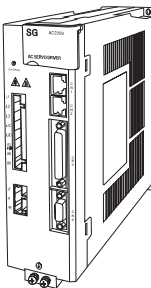

SG-AS30\*\* Current: 30A  
 Output power: 0.2KW-2.6KW

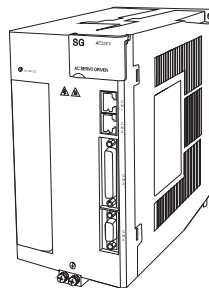

SG-AS50/75 Current 50A/ 75A  
 Output Power: 2.0KW-5KW / 2.0KW-7.5KW

# SERVOPACK Installation

---

# 2

This chapter provides information on installing SERVOPACKs in the required locations.

<b>2.1</b>	<b>Installation Precautions . . . . .</b>	<b>2-2</b>
<b>2.2</b>	<b>Mounting Types and Orientation . . . . .</b>	<b>2-3</b>
<b>2.3</b>	<b>Mounting Interval . . . . .</b>	<b>3-6</b>
2.3.1	Installing One SERVOPACK in a Control Panel . . . . .	2-5
2.3.2	Installing More Than One SERVOPACK in a Control Panel . . . . .	2-5
<b>2.4</b>	<b>Derating Specifications . . . . .</b>	<b>2-6</b>

## 2.1 Installation Precautions

### ■ Installation Near Sources of Heat

Implement measures to prevent temperature increases caused by radiant or convection heat from heat sources so that the ambient temperature of the SERVOPACK meets the ambient conditions.

### ■ Installation Near Sources of Vibration

Install a vibration absorber on the installation surface of the SERVOPACK so that the SERVOPACK will not be subjected to vibration.

### ■ Other Precautions

Do not install the SERVOPACK in a location subject to high temperatures, high humidity, water drops, cutting oil, excessive dust, excessive dirt, excessive iron powder, corrosive gasses, or radioactivity.

# 2.2 Mounting Types and Orientation

The SERVOPACKs come in the following mounting types: base-mounted, rack-mounted, and duct-ventilated types. Regardless of the mounting type, mount the SERVOPACK vertically, as shown in the following figures.

Also, mount the SERVOPACK so that the front panel is facing toward the operator.

Note: Prepare two to four mounting holes for the SERVOPACK and mount it securely in the mounting holes. (The number of mounting holes depends on the capacity of the SERVOPACK.)

- Base-mounted SERVOPACK

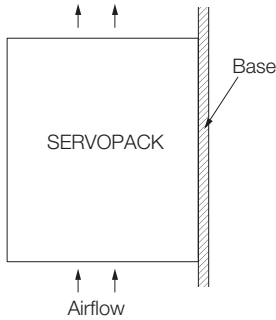

- Rack-mounted SERVOPACK

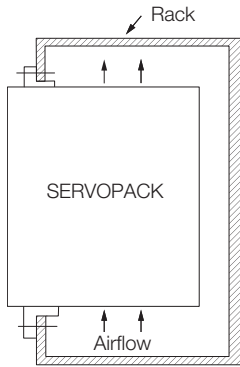

- Duct-ventilated SERVOPACK

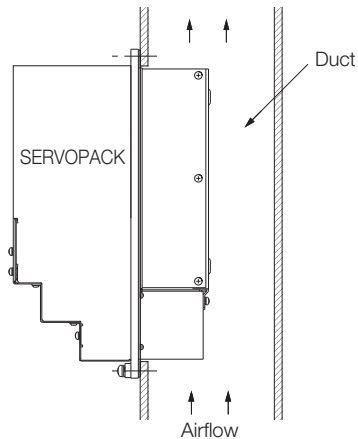

## 2.2 Mounting Hole Dimensions

Use mounting holes to securely mount the SERVOPACK to the mounting surface.

Note: To mount the SERVOPACK, you will need to prepare a screwdriver that is longer than the depth of the SERVOPACK.

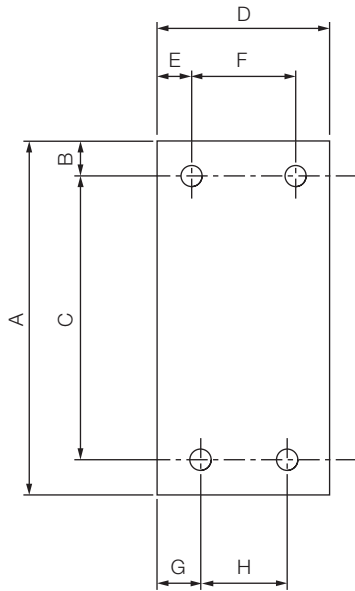

## 2.3 Mounting Interval

### 2.3.1 Installing One SERVOPACK in a Control Panel

Provide the following spaces around the SERVOPACK.

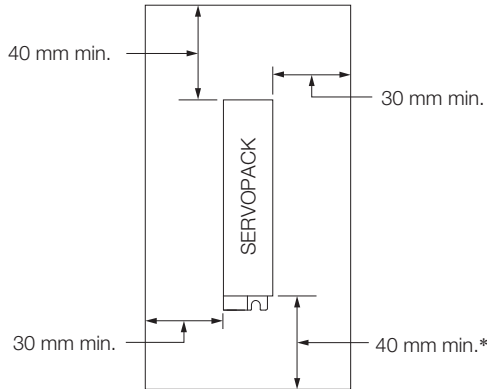

\* For this dimension, ignore items protruding from the main body of the SERVOPACK.

### 2.3.2 Installing More Than One SERVOPACK in a Control Panel

Provide the following intervals between the SERVOPACKs and spaces around the SERVOPACKs.

 **Important** Install cooling fans above the SERVOPACKs so that hot spots do not occur around the SERVOPACKs. Provide sufficient intervals and spaces as shown in the following figure to enable cooling by the fans and natural convection.

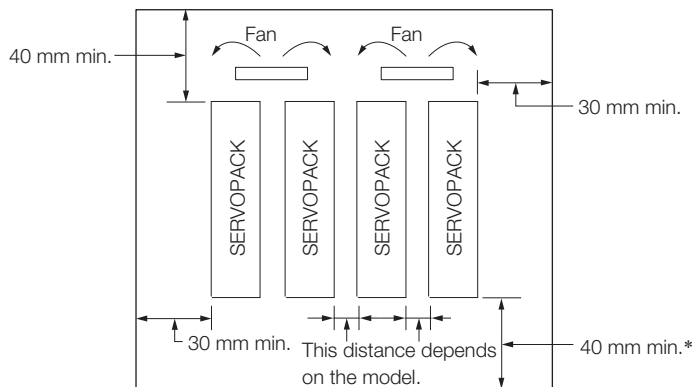

## 2.4 Derating Specifications

If you use the SERVOPACK at a surrounding air temperature of 50°C to 60°C or at an altitude of 1,000 m to 2,000 m, you must apply the derating rates given in the following graphs.

- SGD7S-R70A, -R90A, -1R6A, -2R8A, -R70F, -R90F, -2R1F, and -2R8F

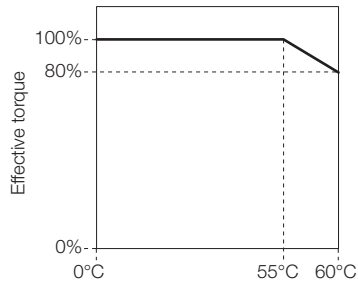

Surrounding air temperature

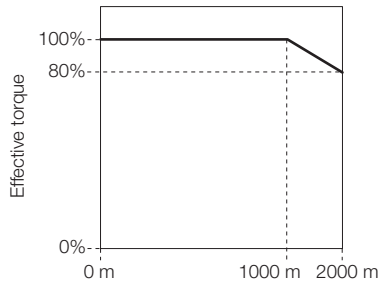

Altitude

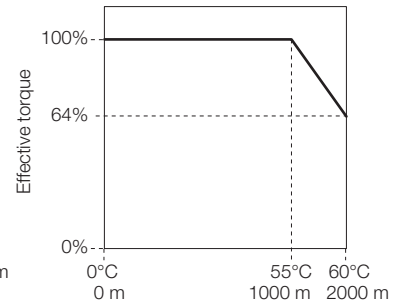

Surrounding air temperature and altitude

# Wiring and Connecting SERVOPACKs

# 3

This chapter provides information on wiring and connecting SERVOPACKs to power supplies and peripheral devices.

<b>3.1</b>	<b>Wiring and Connecting SERVOPACKs . . . .</b>	<b>3-1</b>
3.1.1	General Precautions . . . . .	3-2
3.1.2	Countermeasures against Noise . . . . .	3-3
3.1.3	Grounding . . . . .	3-6
<b>3.2</b>	<b>Basic Wiring Diagrams . . . . .</b>	<b>3-7</b>
<b>3.3</b>	<b>Wiring the Power Supply to the SERVOPACK . .</b>	<b>3-8</b>
3.3.1	Terminal Symbols and Terminal Names . . . . .	3-8
<b>3.4</b>	<b>Wiring Servomotors . . . . .</b>	<b>3-9</b>
3.4.1	Terminal Symbols and Terminal Names . . . . .	3-9
3.4.2	Pin Arrangement of Encoder Connector (CN4) . . . . .	3-9
3.4.3	Wiring the SERVOPACK to the Holding Brake . .	3-10
<b>3.5</b>	<b>I/O Signal Connections . . . . .</b>	<b>3-11</b>
3.5.1	I/O Signal Connector (CN1) Names and Functions . . . . .	3-11
3.5.3	I/O Signal Wiring Examples . . . . .	3-13
3.5.4	I/O Circuits . . . . .	3-16

## 3.1 Wiring and Connecting SERVOPACKs

### 3.1.1 General Precautions



#### DANGER

- Do not change any wiring while power is being supplied.  
There is a risk of electric shock or injury.



#### WARNING

- Wiring and inspections must be performed only by qualified engineers.  
There is a risk of electric shock or product failure.
- Check all wiring and power supplies carefully.  
Incorrect wiring or incorrect voltage application to the output circuits may cause short-circuit failures. If a short-circuit failure occurs as a result of any of these causes, the holding brake will not work. This could damage the machine or cause an accident that may result in death or injury.
- Connect the AC power supplies to the specified SERVOPACK terminals.
  - Connect an AC power supply to the L1, L2, and L3 terminals and the L1C and L2C terminals on the SERVOPACK.  
There is a risk of failure or fire.
- If you use a SERVOPACK with the Dynamic Brake Hardware Option, connect an External Dynamic Brake Resistor that is suitable for the machine and equipment specifications to the specified terminals.  
There is a risk of unexpected operation, machine damage, burning, or injury when an emergency stop is performed.

## CAUTION

- Wait for at least six minutes after turning OFF the power supply (with a SERVOPACK for a 100-VAC power supply input, wait for at least nine minutes) and then make sure that the CHARGE indicator is not lit before starting wiring or inspection work. Do not touch the power supply terminals while the CHARGE lamp is lit after turning OFF the power supply because high voltage may still remain in the SERVOPACK.  
There is a risk of electric shock.
- Observe the precautions and instructions for wiring and trial operation precisely as described in this document.  
Failures caused by incorrect wiring or incorrect voltage application in the brake circuit may cause the SERVOPACK to fail, damage the equipment, or cause an accident resulting in death or injury.
- Check the wiring to be sure it has been performed correctly.  
Connectors and pin layouts are sometimes different for different models. Always confirm the pin layouts in technical documents for your model before operation.  
There is a risk of failure or malfunction.
- Connect wires to power supply terminals and motor connection terminals securely with the specified methods and tightening torque.  
Insufficient tightening may cause wires and terminal blocks to generate heat due to faulty contact, possibly resulting in fire.
- Use shielded twisted-pair cables or screened unshielded multi-twisted-pair cables for I/O Signal Cables and Encoder Cables.
- Observe the following precautions when wiring the SERVOPACK's main circuit terminals.
  - Turn ON the power supply to the SERVOPACK only after all wiring, including the main circuit terminals, has been completed.
  - If a connector is used for the main circuit terminals, remove the main circuit connector from the SERVOPACK before you wire it.
  - Insert only one wire per insertion hole in the main circuit terminals.
  - When you insert a wire, make sure that the conductor wire (e.g., whiskers) does not come into contact with adjacent wires.
- Install molded-case circuit breakers and other safety measures to provide protection against short circuits in external wiring.  
There is a risk of fire or failure.

## NOTICE

- Whenever possible, use the Cables specified by YUHA1.  
If you use any other cables, confirm the rated current and application environment of your model and use the wiring materials specified by Yaskawa or equivalent materials.
- Securely tighten cable connector screws and lock mechanisms.  
Insufficient tightening may result in cable connectors falling off during operation.
- Do not bundle power lines (e.g., the Main Circuit Cable) and low-current lines (e.g., the I/O Signal Cables or Encoder Cables) together or run them through the same duct. If you do not place power lines and low-current lines in separate ducts, separate them by at least 30 cm. If the cables are too close to each other, malfunctions may occur due to noise affecting the low-current lines.
- Install a battery at either the host controller or on the Encoder Cable.  
If you install batteries both at the host controller and on the Encoder Cable at the same time, you will create a loop circuit between the batteries, resulting in a risk of damage or burning.
- When connecting a battery, connect the polarity correctly.  
There is a risk of battery rupture or encoder failure.



- Use a molded-case circuit breaker (1QF) or fuse to protect the main circuit. The SERVOPACK connects directly to a commercial power supply; it is not isolated through a transformer or other device. Always use a molded-case circuit breaker (1QF) or fuse to protect the servo system from accidents involving different power system voltages or other accidents.
- Install an earth leakage breaker. The SERVOPACK does not have a built-in ground fault protective circuit. To configure a safer system, install a ground fault detector against overloads and short-circuiting, or install a ground fault detector combined with a molded-case circuit breaker.
- Do not turn the power supply ON and OFF more than necessary.
  - Do not use the SERVOPACK for applications that require the power supply to turn ON and OFF frequently. Such applications will cause elements in the SERVOPACK to deteriorate.
  - After you have started actual operation, allow at least one hour between turning the power supply ON and OFF (as a guideline).

To ensure safe, stable application of the servo system, observe the following precautions when wiring.

- Use the cables specified by Yaskawa. Design and arrange the system so that each cable is as short as possible.
- The signal cable conductors are as thin as 0.2 mm<sup>2</sup> or 0.3 mm<sup>2</sup>. Do not subject them to excessive bending stress or tension.

## 3.1.2 Countermeasures against Noise



The SERVOPACK is designed as an industrial device. It therefore provides no measures to prevent radio interference. The SERVOPACK uses high-speed switching elements in the main circuit. Therefore peripheral devices may be affected by switching noise. If the equipment is to be used near private houses or if radio interference is a problem, take countermeasures against noise.

The SERVOPACK uses microprocessors. Therefore, it may be affected by switching noise from peripheral devices.

To prevent the noise from the SERVOPACK or the peripheral devices from causing malfunctions of any devices, take the following countermeasures against noise as required.

- Install the input reference device and Noise Filter as close to the SERVOPACK as possible.
- Always install a Surge Absorber for relays, solenoids, and Magnetic Contactor coils.
- Do not place the following cables in the same duct or bundle them together. Also, separate the cables from each other by at least 30 cm.
  - Main Circuit Cables and I/O Signal Cables
  - Main Circuit Cables and Encoder Cables
- Do not share the power supply with an electric welder or electrical discharge machine. If the SERVOPACK is placed near a high-frequency generator, install Noise Filters on the input side on the Main Circuit Power Supply Cable and Control Power Supply Cable even if the same power supply is not shared with the high-frequency generator.
- Implement suitable grounding measures.

## Noise Filters

You must attach Noise Filters in appropriate places to protect the SERVOPACK from the adverse effects of noise. The following is an example of wiring for countermeasures against noise.

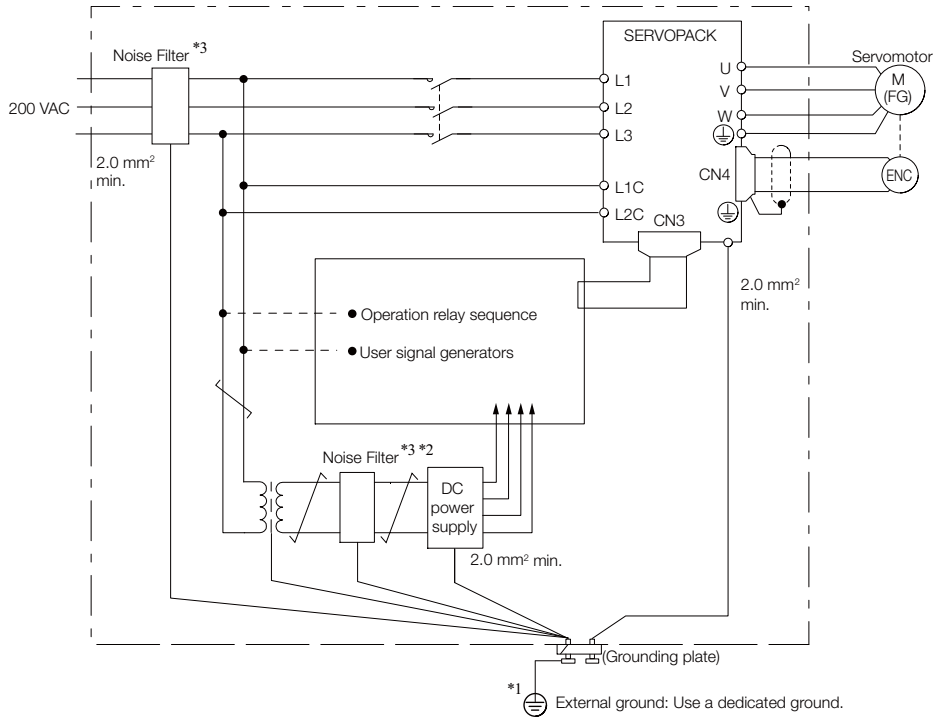

\*1. For the ground wire, use a wire with a thickness of at least 2.0 mm<sup>2</sup> (preferably, flat braided copper wire).

\*2. Whenever possible, use twisted-pair wires to wire all connections marked with .

\*3. Refer to the following section for precautions when using Noise Filters.

## Noise Filter Wiring and Connection Precautions

Always observe the following precautions when wiring or connecting Noise Filters.

- Separate input lines from output lines. Do not place input lines and output lines in the same duct or bundle them together.

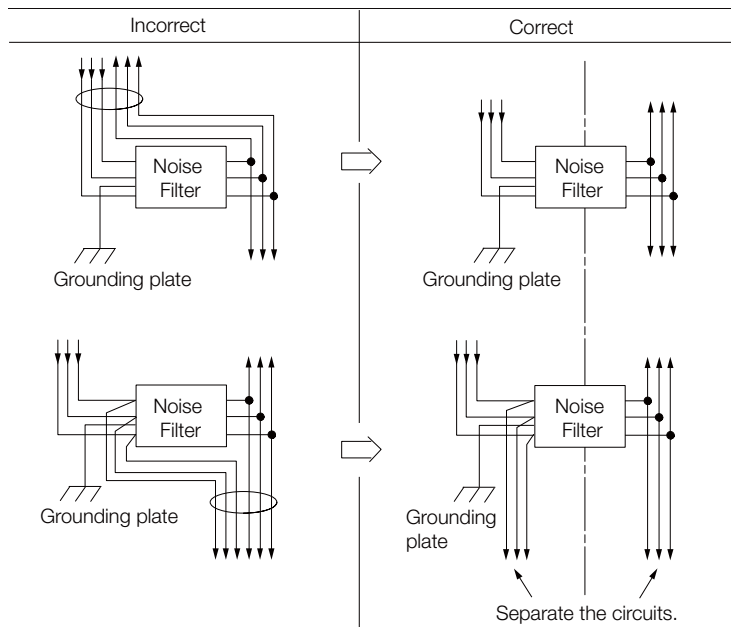

- Separate the Noise Filter ground wire from the output lines. Do not place the Noise Filter ground wire, output lines, and other signal lines in the same duct or bundle them together.

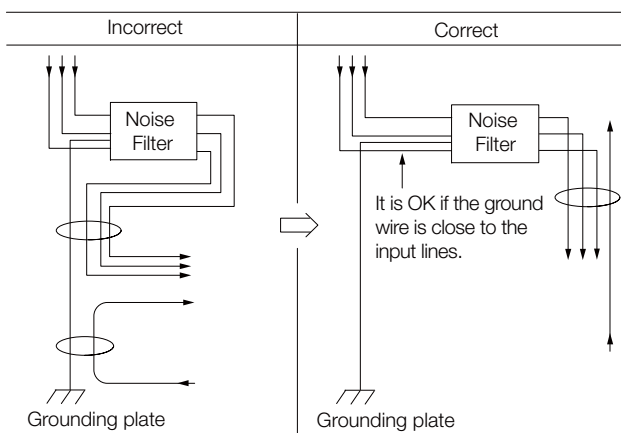

- Connect the Noise Filter ground wire directly to the grounding plate. Do not connect the Noise Filter ground wire to other ground wires.

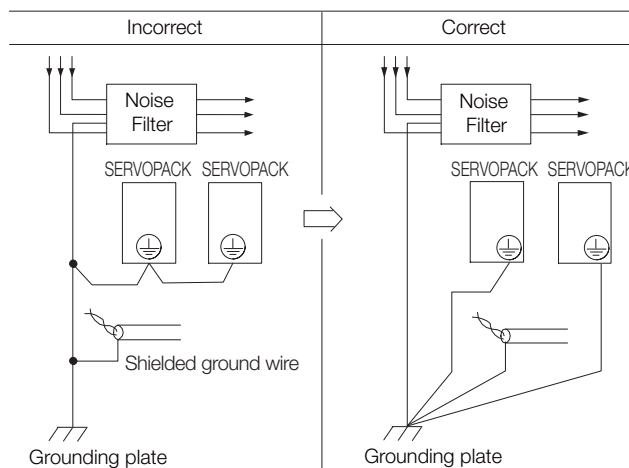

- If a Noise Filter is located inside a control panel, first connect the Noise Filter ground wire and the ground wires from other devices inside the control panel to the grounding plate for the control panel, then ground the plate.

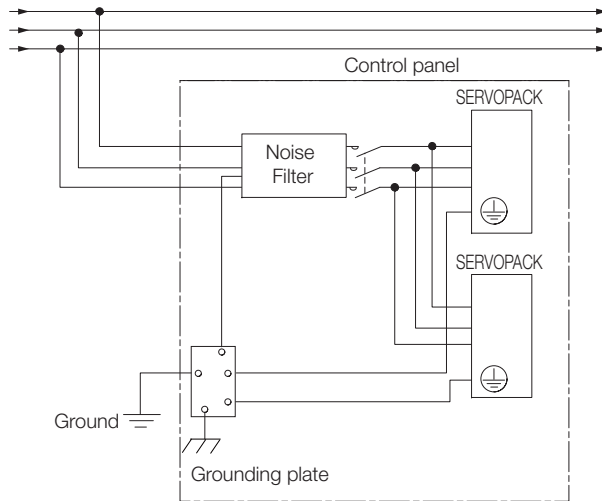

### 3.1.3 Grounding

Implement grounding measures as described in this section. Implementing suitable grounding measures will also help prevent malfunctions, which can be caused by noise.

Observe the following precautions when wiring the ground cable.

- Ground the SERVOPACK to a resistance of 100  $\Omega$  or less.
- Be sure to ground at one point only.
- Ground the Servomotor directly if the Servomotor is insulated from the machine.

#### Motor Frame Ground or Motor Ground

If you ground the Servomotor through the machine, switching noise current can flow from the main circuit of the SERVOPACK through the stray capacitance of the Servomotor. To prevent this, always connect the motor frame terminal (FG) or ground terminal (FG) of the Servomotor to the ground terminal  $\oplus$  on the SERVOPACK. Also be sure to ground the ground terminal  $\oplus$ .

#### Noise on I/O Signal Cables

If noise enters the I/O Signal Cable, connect the shield of the I/O Signal Cable to the connector shell to ground it. If the Servomotor Main Circuit Cable is placed in a metal conduit, ground the conduit and its junction box. For all grounding, ground at one point only.

3.2

Basic Wiring Diagrams

This section provide the basic wiring diagrams. Refer to the reference sections given in the diagrams for details.

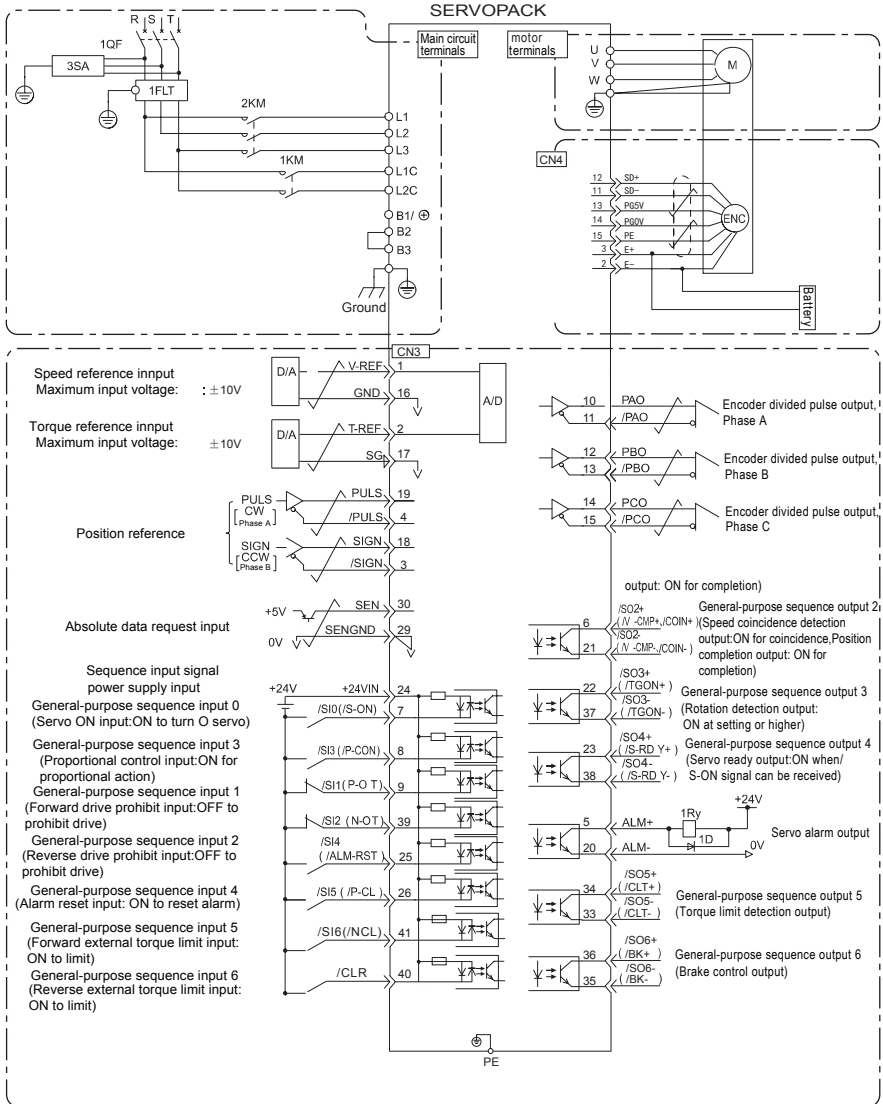

### 3.3 Wiring the Power Supply to the SERVOPACK

#### 3.3.1 Terminal Symbols and Terminal Names

### 3.3 Wiring the Power Supply to the SERVOPACK

#### 3.3.1 Terminal Symbols and Terminal Names

Use the main circuit connector on the SERVOPACK to wire the main circuit power supply and control circuit power supply to the SERVOPACK.

Terminal Symbols	Terminal Name	Specifications and Reference
L1, L2, L3	Main circuit power supply input terminals	Three phase AC 220V (-15%~10%, 50/60Hz)
L1C, L2C	Control power supply terminals	Single-phase AC 220V(-15%~10%, 50/60Hz)
B1/, B2, B3	Brake resistance terminals	Connect a brake resistance between B1/B2 when use outer brake resistor. Short B2 and B3 when use internal brake resistance. Note: Do not short B1 and B2.
PE	Ground terminals	Connect with power supply ground terminals and motor ground terminals,do grounding
CN1.CN2	Communication terminals	Refer to wiring diagrams
CN3	Control signal terminals	Refer to wiring diagrams
CN4	Motor encoder terminals	Refer to wiring diagrams

#### CN4 Encoder terminals definition

Terminal No.	2	3	11	12	13	14	15
Definition	E-	E+	SD-	SD+	+5V	GND	PE

#### CN1,CN2 General terminals definition

Terminal No.	1	2	3	4	5	6	7	8
Definition	CN1	CANH	CANL	GND	RS485+	RS485-	GND	Built-in resistance
	CN2	CANH	CANL	GND	Rs485+	Rs485-	GND	Retain Retain

#### CN3 Signal terminals definition

Terminal No.	Signal	Terminal Name	Terminal No.	Signal	Terminal Name
19	PULS+	Pulse Reference Input	36	SO6+	General-purpose Sequence Outputs
4	PULS-		35	SO6-	Brake control output
18	SIGN+	Sign of Reference Input	30	SEN	Absolute data request input
3	SIGN-		29	FG	
1	V-REF	Speed Reference input(Max.10V)	10	PAO+	Encoder divided pulse output Phase A
16	GND	Ground	11	PAO-	
2	T-REF	Torque Reference Input(Max.10V)	12	PBO+	Encoder divided pulse output Phase B
17	GND	Ground	13	PBO-	
5	ALM+	Servo alarm output	14	PCO+	Encoder divided pulse output Phase C
20	ALM-		15	PCO-	
6	So2+	General-purpose Sequence Output 2 (V-CMP/COIN)	7	/SI0(/S-ON)	General-purpose Sequence input 0
21	SO2-	Speed coincidence output/ Position completion output	8	/SI3(/P-CON)	General-purpose Sequence input 3
22	SO3+	General-purpose Sequence Output 3 (/TGON)	9	/SI1(P-OT)	General-purpose Sequence input 1
37	SO3-	Rotation detection output	39	/SI2(N-OT)	General-purpose Sequence input 2
23	SO4+	General-purpose Sequence Output 4 (S-RDY)	25	/SI4(ALM-RST)	General-purpose Sequence input 4
38	SO4-	Servo ready output	26	/SI5(P-4)	General-purpose Sequence input 5
34	SO5+	General-purpose Sequence Output 5	41	/SI6(N-4)	General-purpose Sequence input 6
33	SO5-	Torque limit detection output	40	/CLR	Position deviation clear input

## 3.4 Wiring Servomotors

### 3.4.1 Terminal Symbols and Terminal Names

The SERVOPACK terminals or connectors that are required to connect the SERVOPACK to a Servomotor are given below.

Terminal/Connector Symbols	Terminal/Connector Name	Remarks
U, V, and W	Servomotor terminals	Motor PE terminal connect.
	Ground terminal	-
CN2	Encoder connector	-

### 3.4.2 Pin Arrangement of Encoder Connector (CN4)

- When using a absolute servo motor

Pin No.	Signal	Function
13	PG5V	Encoder power supply +5 V
14	PG0V	Encoder power supply 0 V
3	E +	Battery for absolute encoder (+)
2	E -	Battery for absolute encoder (-)
12	SD+	Serial data (+)
11	SD-	Serial data (-)
15	PE	Shield

- When using a incremental servo motor

Pin No.	Signal	Function
13	PG5V	Encoder power supply +5 V
14	PG0V	Encoder power supply 0 V
5	A+	Encoder A+
10	A-	Encoder A-
4	B+	Encoder B+
9	B-	Encoder B-
3	C+	Encoder C+
8	C-	Encoder C-
2	U+	Encoder U+
7	U-	Encoder U-
1	V+	Encoder V+
6	V-	Encoder V-
12	W+	Encoder W+
11	W-	Encoder W-
15	PE	Shield

## 3.4.3 Wiring the SERVOPACK to the Holding Brake

Servo motor with holding brake wiring sample.

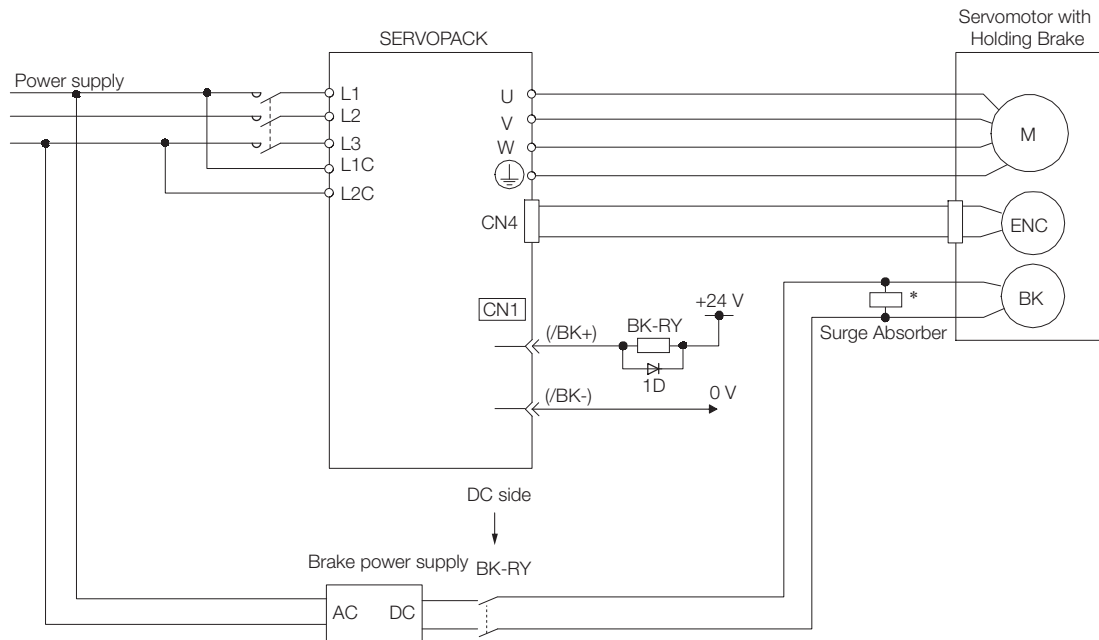

\* BK-RY: Brake control relay  
1D: Flywheel diode

## 3.5 I/O Signal Connections

### 3.5.1 I/O Signal Connector (CN3) Names and Functions

The following table gives the pin numbers, names, and functions the I/O signal pins for the default settings.

#### Input Signals

Default settings are given in parentheses.

Control Method	Signal	Pin No.	Name	Function
Any Control Method	/SI0* (/S-ON)	7	General-purpose Sequence Input 0 (Servo ON Input)	You can allocate the input signal to use with a parameter. (Controls turning the Servomotor ON and OFF (supplying/not supplying power).)
	/SI3* (/P-CON)	8	General-purpose Sequence Input 3 (Proportional Control Input)	You can allocate the input signal to use with a parameter. (Changes the speed control loop from PI (proportional/integral) to P (proportional) control when turned ON.)
	/SI1* (P-OT)	9	General-purpose Sequence Input 1 (Forward Drive Prohibit Input)	You can allocate the input signals to use with parameters. (Stops Servomotor drive (to prevent over-travel) when the moving part of the machine exceeds the range of movement.)
	/SI2* (N-OT)	39	General-purpose Sequence Input 2 (Reverse Drive Prohibit Input)	
	/SI5* (/P-CL)	26	General-purpose Sequence Input 5 (Forward External Torque Limit Input)	You can allocate the input signals to use with parameters. (Activates/deactivates external torque limiting.)
	/SI6* (/N-CL)	41	General-purpose Sequence Input 6 (Reverse External Torque Limit Input)	
	/SI4* (/ALM-RST)	25	General-purpose Sequence Input 4 (Alarm Reset Input)	You can allocate the input signal to use with a parameter. (Clears alarms.)
	+24VIN	24	Sequence Input Signal Power Supply Input	Inputs the sequence input signal power supply. Allowable voltage range: 24 VDC $\pm$ 20% The 24-VDC power supply is not provided by YUHA1.
	SEN	30	Absolute Data Request Input (SEN)	Inputs the position data request signal for an absolute encoder.
Speed Control	V-REF	1 (16)	Speed Reference	Inputs the speed reference. Maximum input voltage: $\pm$ 10 V
Position Control	PULS /PULS	19 4	Pulse Reference Input	One of the following input pulse forms is set. <ul style="list-style-type: none"> <li>• Sign + pulse train</li> <li>• CW + CCW pulse trains</li> <li>• 90° phase-differential pulses</li> </ul>
	SIGN /SIGN	18 3	Sign of Reference Input	
	CLR /CLR	40 24	Position Deviation Clear Input	Clears the position deviation during position control.
Torque Control	T-REF	2 (11)	Torque Reference Input	Inputs the torque reference. Maximum input voltage: $\pm$ 10 V

## Output Signals

Default settings are given in parentheses.

Control Method	Signal	Pin No.	Name	Function
Any Control Method	ALM+	5	Servo Alarm Output	Turns OFF (opens) when an error is detected.
	ALM-	20		
	/SO2+* (/TGON+)	22	General-purpose Sequence Output 2 (Rotation Detection Output)	You can allocate the output signal to use with a parameter. (Turns ON (closes) when the Servomotor speed exceeds a set value.)
	/SO2-* (/TGON-)	37		
	/SO3+* (/S-RDY+)	23	General-purpose Sequence Output 3 (Servo Ready Output)	You can allocate the output signal to use with a parameter. (Turns ON (closes) when the SERVO-PACK is ready to acknowledge the /S-ON (Servo ON) signal.)
	/SO3-* (/S-RDY-)	38		
	PAO	10	Encoder Divided Pulse Output, Phase A	Output the encoder divided pulse output signals with a 90° phase differential.
	/PAO	11		
	PBO	12	Encoder Divided Pulse Output, Phase B	
	/PBO	13		
	PCO	14	Encoder Divided Pulse Output, Phase C	Outputs the origin signal once every encoder rotation.
	/PCO	15		
	FG	Shell	Frame ground	Connected to the frame ground if the shield of the I/O Signal Cable is connected to the connector shell.
Speed Control	/SO1+* (/V-CMP+)	6	General-purpose Sequence Output 1 (Speed Coincidence Detection Output)	You can allocate the output signal to use with a parameter. (Turns ON (closes) if the motor speed is within the set range and matches the reference speed value when speed control is selected.)
	/SO1-* (/V-CMP-)	21		
Position Control	/SO1+* (/COIN+)	6	General-purpose Sequence Output 1 (Positioning Completion Output)	You can allocate the output signals to use with parameters. (Turns ON (closes) if the position deviation reaches the set value when position control is selected.)
	/SO1-* (/COIN-)	21		

## 3.5.2 I/O Signal Wiring Examples

### Speed Control

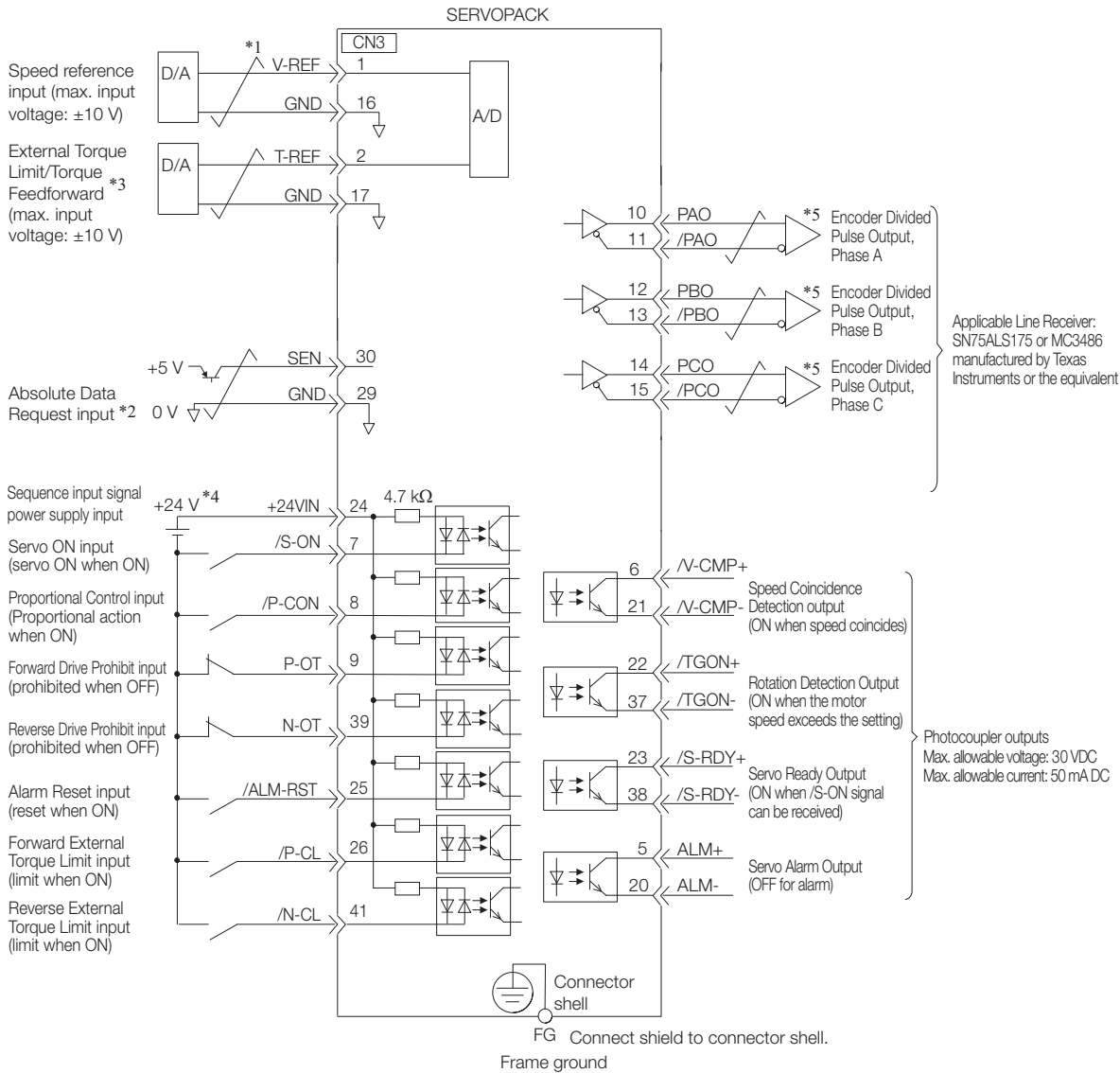

- \*1. represents twisted-pair wires.
- \*2. Connect these when using an absolute encoder. If the Encoder Cable with a Battery Case is connected, do not connect a backup battery.
- \*3. You can enable this function with a parameter setting.
- \*4. The 24-VDC power supply is not provided by the user. Use a 24-VDC power supply with double insulation or reinforced insulation.
- \*5. Always use line receivers to receive the output signals.

Note: If you use a 24-V brake, install a separate power supply for the 24-VDC power supply from other power supplies, such as the one for the I/O signals of the CN3 connector.  
 If the power supply is shared, the I/O signals may malfunction.

# Position Control

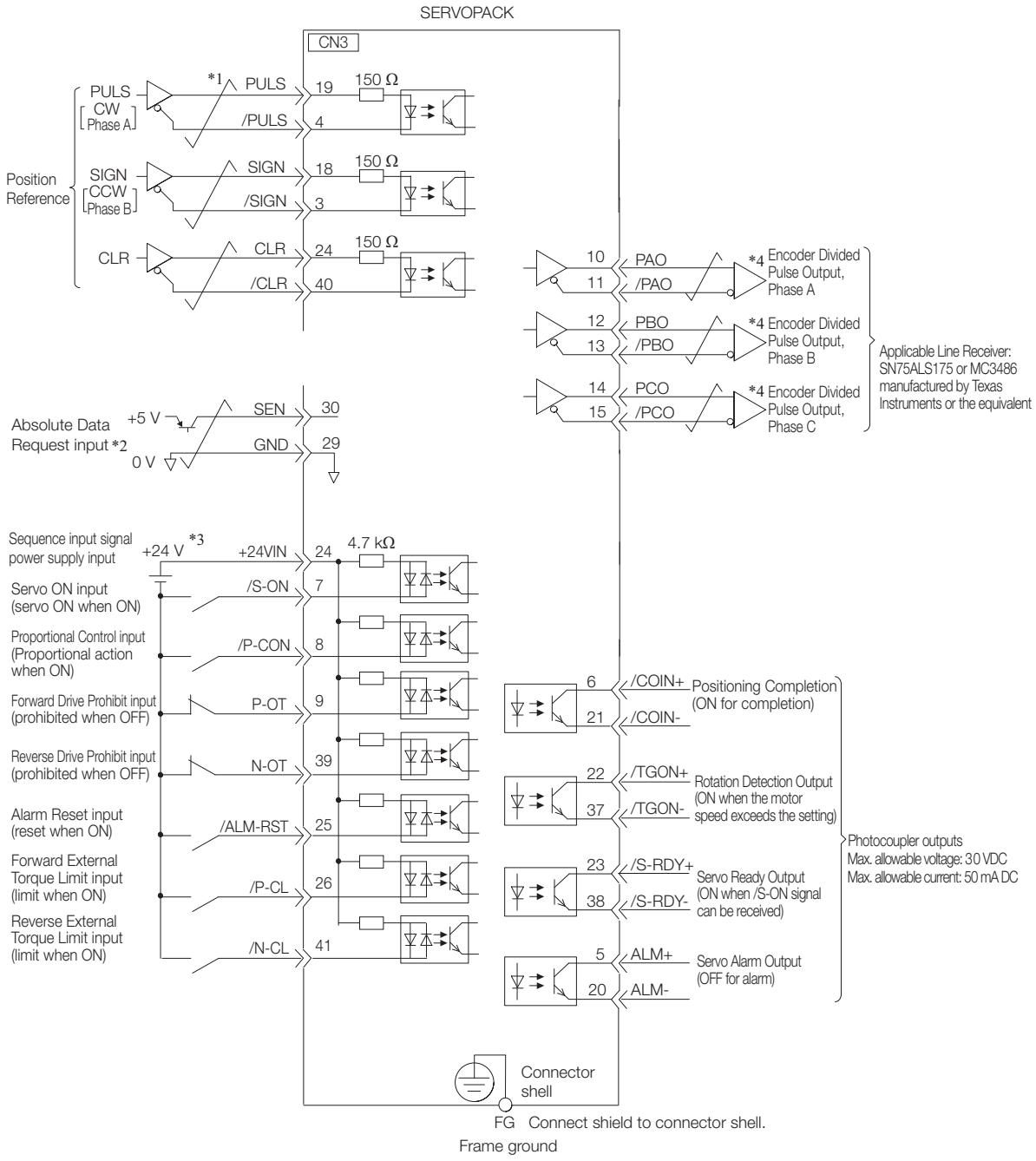

- \*1. represents twisted-pair wires.
  - \*2. Connect these when using an absolute encoder. If the Encoder Cable with a Battery Case is connected, do not connect a backup battery.
  - \*3. The 24-VDC power supply is not provided by Yaskawa. Use a 24-VDC power supply with double insulation or reinforced insulation.
  - \*4. Always use line receivers to receive the output signals.
- Note: If you use a 24-V brake, install a separate power supply for the 24-VDC power supply from other power supplies, such as the one for the I/O signals of the CN3 connector. If the power supply is shared, the I/O signals may malfunction.

# Torque Control

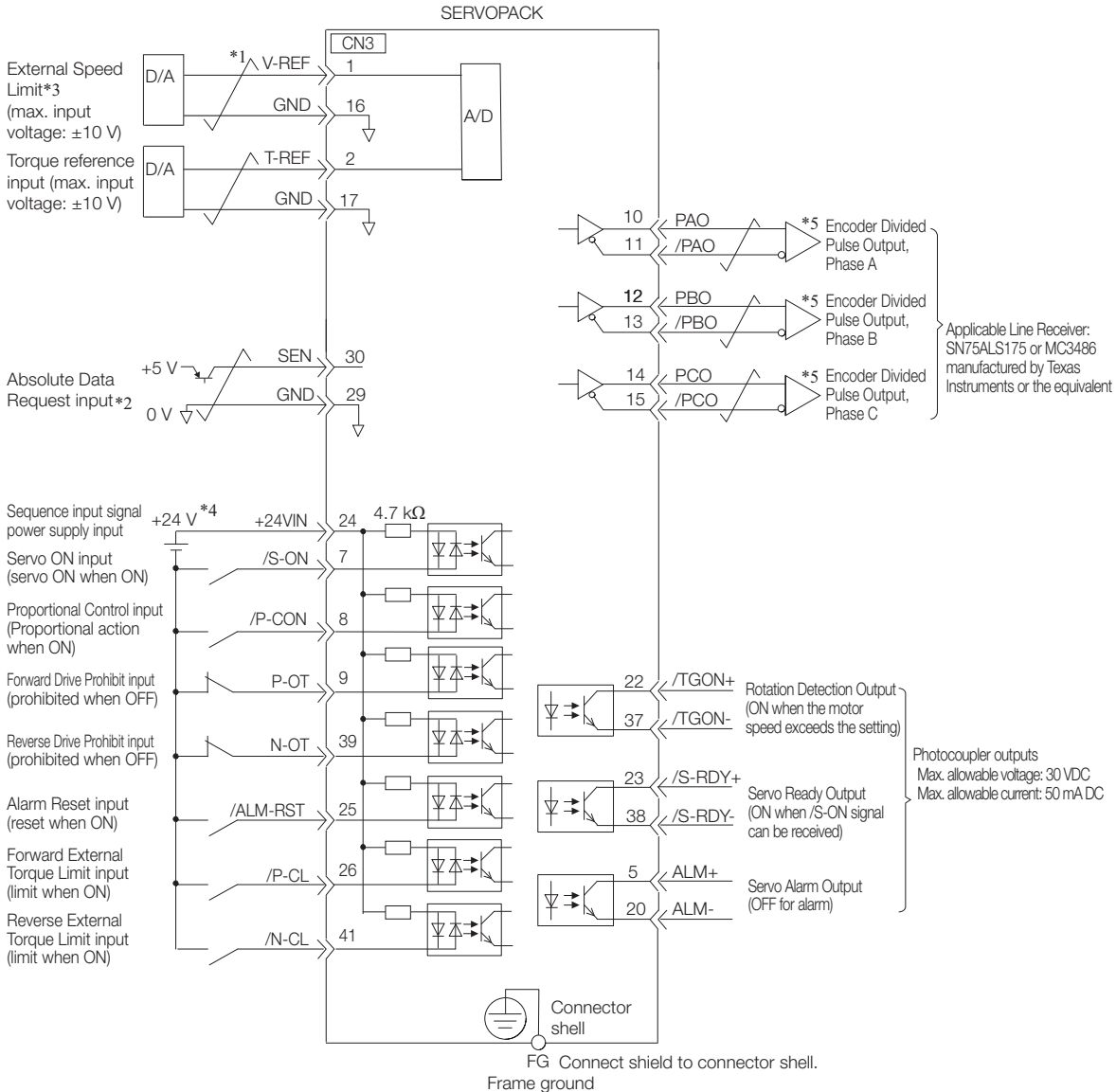

- \*1. represents twisted-pair wires.
- \*2. Connect these when using an absolute encoder. If the Encoder Cable with a Battery Case is connected, do not connect a backup battery.
- \*3. You can enable this function with a parameter setting.
- \*4. The 24-VDC power supply is not provided by Yaskawa. Use a 24-VDC power supply with double insulation or reinforced insulation.
- \*5. Always use line receivers to receive the output signals.

Note: If you use a 24-V brake, install a separate power supply for the 24-VDC power supply from other power supplies, such as the one for the I/O signals of the CN3 connector. If the power supply is shared, the I/O signals may malfunction.

## 3.5.3 I/O Circuits

### Reference Input Circuits

#### ◆ Analog Input Circuits

This section describes CN3 connector terminals 1-16 (Speed Reference Input) and 2-17 (Torque Reference Input).

The analog signals are used as either speed or torque reference signals. The input impedance is as follows:

- Speed Reference Input: Approx. 14 k $\Omega$
- Torque Reference Input: Approx. 14 k $\Omega$

The maximum allowable voltage for input signals is  $\pm 10$  V.

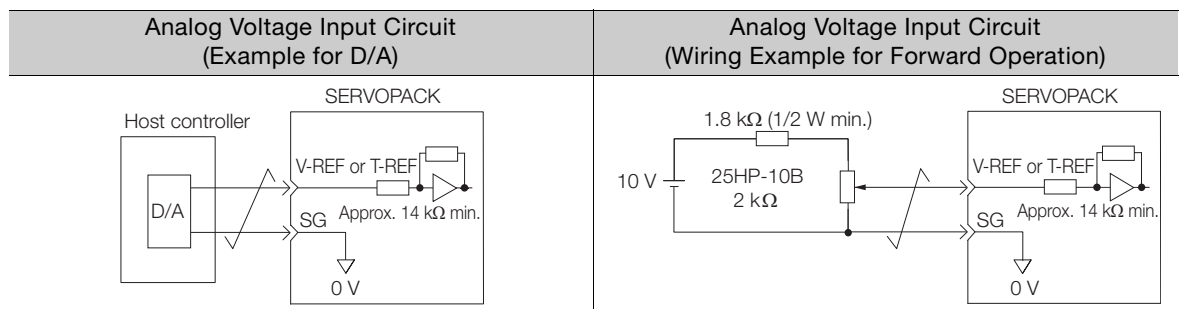

#### ◆ Position Reference Input Circuits

This section describes CN3 connector terminals 19-4 (Reference Pulse Input), 18-3 (Reference Sign Input), and 40-24 (Clear Input).

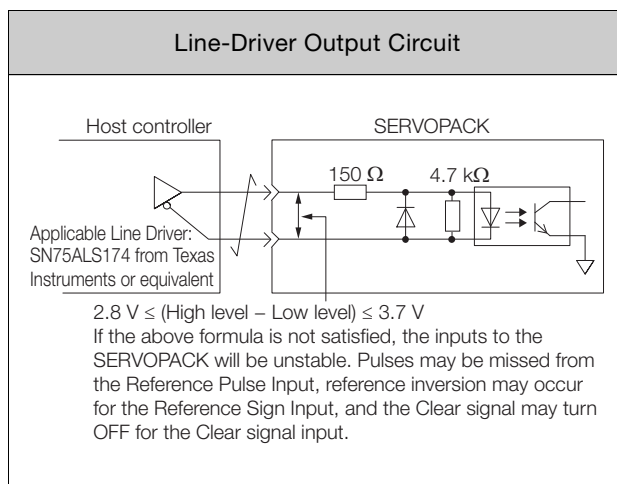

## Sequence Input Circuits

### ◆ Photocoupler Input Circuits

This section describes CN3 connector terminals 7 to 24. The circuits are connected through relay or open-collector transistor circuits. If you connect through a relay, use a low-current relay. If you do not use a low-current relay, a faulty contact may result.

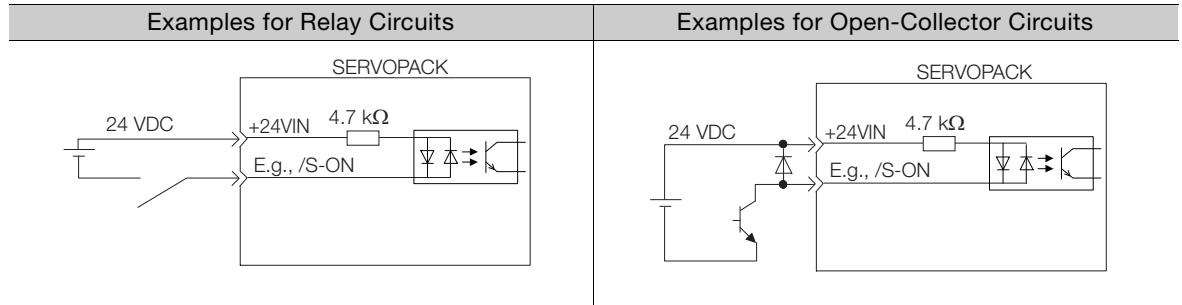

Note: The 24-VDC external power supply capacity must be 50 mA minimum.

The SERVOPACK input circuits use bidirectional photocouplers. Select either a sink circuit or source circuit according to the specifications required by the machine.

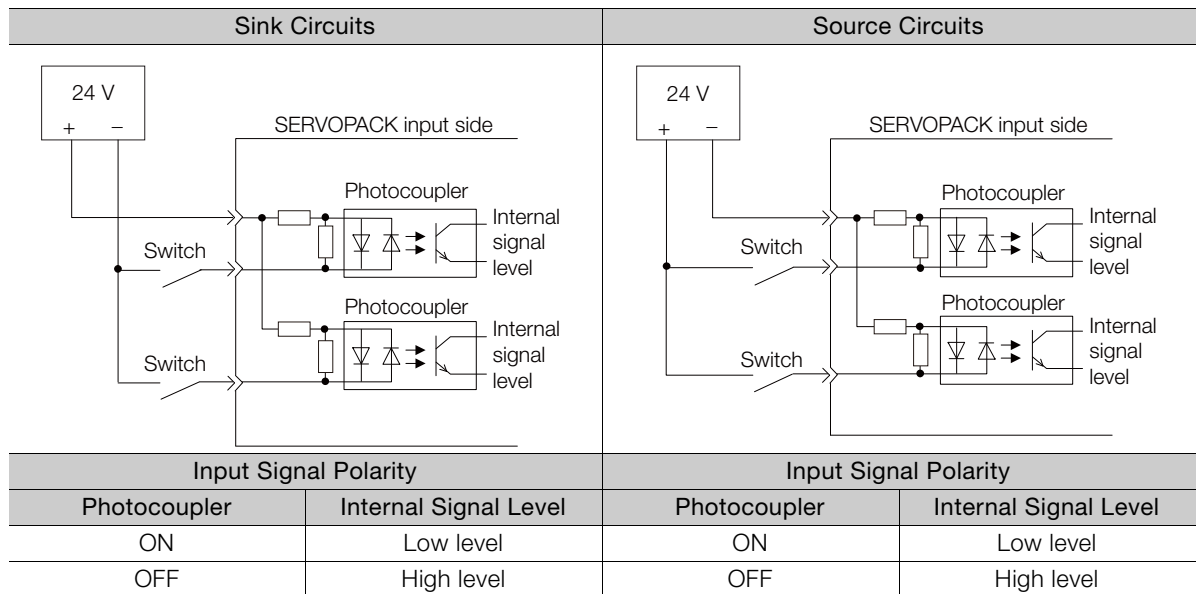

## Sequence Output Circuits

### ◆ Photocoupler Output Circuits

Photocoupler output circuits are used for the ALM (Servo Alarm), /S-RDY (Servo Ready), and other sequence output signals. Connect a photocoupler output circuit to a relay or line-receiver circuit.

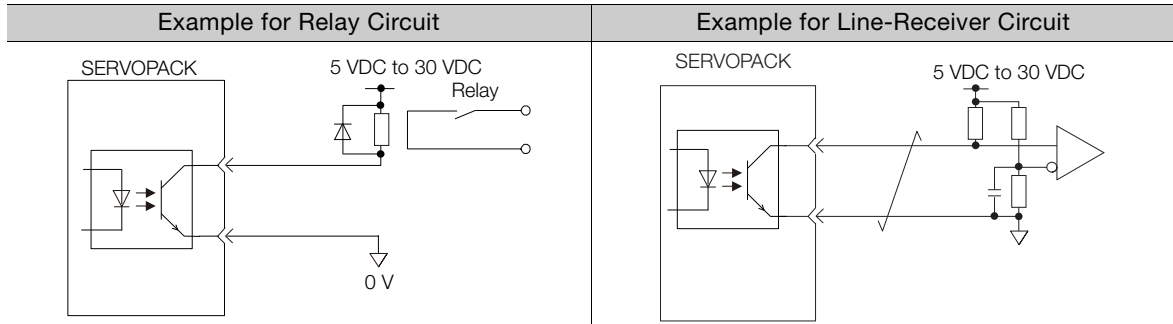

Note: The maximum allowable voltage and current range for photocoupler output circuits are as follows:

- Maximum allowable voltage: 30 VDC
- Current range: 5 mA to 50 mA DC

### ◆ Line-Driver Output Circuits

This section describes CN3 connector pins 10-11 (Phase-A Signal), 12-13 (Phase-B Signal), 14-15 (Phase-C Signal).

The serial data from the encoder is converted to two-phase (phases A and B) pulses. The resulting output signals (PAO, /PAO and PBO, /PBO), origin pulse signal (PCO and /PCO), are output with line-driver output circuits. Connect the line-driver output circuits to line-receiver circuits at the host controller.

#### Example for Line-Receiver Circuit

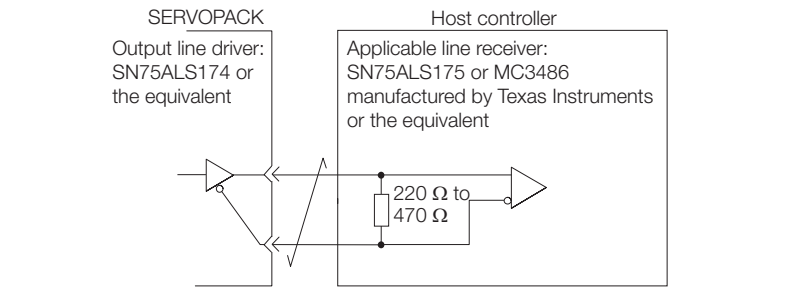

# Basic Functions That Require Setting before Operation

# 4

This chapter describes the basic functions that must be set before you start servo system operation. It also describes the setting methods.

<b>4.1</b>	<b>Manipulating Parameters (Pn□□□ ) . . . . .</b>	<b>4-2</b>
4.1.1	Notation for Parameters . . . . .	4-2
4.1.2	Initializing Parameter Settings . . . . .	4-3
<b>4.2</b>	<b>Control Method Selection . . . . .</b>	<b>4-4</b>
<b>4.3</b>	<b>Automatic Detection of Connected Motor . .</b>	<b>4-5</b>
<b>4.4</b>	<b>Functions and Settings for the /S-ON (Servo ON) Signal . .</b>	<b>4-6</b>
4.4.1	Function of the /S-ON (Servo ON) Signal . . . . .	4-6
<b>4.5</b>	<b>Motor Direction Setting . . . . .</b>	<b>4-7</b>
<b>4.6</b>	<b>Overtravel and Related Settings . . . . .</b>	<b>4-8</b>
4.6.1	Overtravel Signals . . . . .	4-8
4.6.2	Setting to Enable/Disable Overtravel . . . . .	4-8
<b>4.7</b>	<b>Holding Brake . . . . .</b>	<b>4-9</b>
4.7.1	Brake Operating Sequence . . . . .	4-9
4.7.2	/BK (Brake) Signal . . . . .	4-10
4.7.3	Output Timing of /BK (Brake) Signal When the Servomotor Is Stopped . . . . .	4-10
4.7.4	Output Timing of /BK (Brake) Signal When the Servomotor Is Operating . . . . .	4-11
<b>4.8</b>	<b>Motor Stopping Methods for Servo OFF and Alarms . .</b>	<b>4-12</b>
<b>4.9</b>	<b>Electronic Gear Settings . . . . .</b>	<b>4-13</b>
4.9.1	Electronic Gear Ratio Settings . . . . .	4-13
4.9.2	Electronic Gear Ratio Setting Examples . . . . .	4-14
<b>4.10</b>	<b>Resetting the Absolute Encoder . . . . .</b>	<b>4-15</b>
4.10.1	Precautions on Resetting . . . . .	4-15
4.10.2	Preparations . . . . .	4-15
4.10.3	Applicable Tools . . . . .	4-15

## 4.1.1 Notation for Parameters

There are two types of notation used for parameters that depend on whether the parameter requires a numeric setting (parameter for numeric setting) or requires the selection of a function (parameter for selecting a function).

### • Parameters for Numeric Settings

The control methods for which the parameters apply are given.  
 [Speed] : Speed control [Position] : Position control [Torque] : Torque control

Pn100	Speed Loop Gain				
	Setting Range	Setting Unit	Default Setting	When Enabled	Classification
	10 to 20,000	0.1 Hz	400	Immediately	Tuning

Parameter number: This is the setting range for the parameter.

This is the minimum unit (setting increment) that you can set for the parameter.

This is the parameter setting before shipment.

This is when any change made to the parameter will become effective.

This is the parameter classification.

### • Parameters for Selecting Functions

Parameter	Meaning	When Enabled	Classification
Pn002	n.□0□□ (default setting) Use the encoder according to encoder specifications. <b>Make absolute data serial output.</b>	After startup	Setup
	n.□1□□ Use the encoder as an incremental encoder.		
	n.□2□□ Use encoder according to the encoder specification, <b>not let absolute data serial output.</b>		

Parameter number: The notation "n.□□□□" indicates a parameter for selecting functions. Each □ indicates the setting for one digit. The notation shown here means that the third digit from the right is set to 2.

This column explains the selections for the function.

## 4.1.2 Initializing Parameter Settings

You can return the parameters to their default settings.

This function will not initialize the settings of the parameters that are adjusted for the Fn009,Fn00A, Fn00B utility functions.



To enable the new settings, turn the power supply to the SERVOPACK OFF and ON again after you complete the operation.

### Important

### Preparations

Always check the following before you initialize the parameter settings.

- 1.The parameters must not be write prohibited.
- 2.The servo must be OFF.

### Applicable Tools

The following table lists the tools that you can use to initialize the parameter settings and the applicable tool functions.

Tool	Allocation	Reference
Panel Operate	Fn005	Press M/SET Until appears"done"

## 4.2 Control Method Selection

You can use the SERVOPACK for speed control, position control, or torque control.

You set the control method in Pn000 = n.□□X□(Control Method Selection).

Control Method Selection		
Pn000 = n.□□X□	Control Method	Outline
n.□□0□ (default setting)	Speed control	The speed of the Servomotor is controlled with an analog voltage speed reference. Use speed control in the following cases. 1.To control speed 2.For position control using encoder pulse outputs from the SERVOPACK to form a position loop in the host controller
n.□□0□	Position control	The position of the machine is controlled with a pulse train position reference. The position is controlled with the number of input pulses, and the speed is controlled with the input pulse frequency. Use position control when positioning is required.
n.□□0□	Torque control	The torque output by the Servomotor is controlled with an analog voltage torque reference. Use torque control to output the required torque for operations such as pressing.
n.□□0□	Internal set speed control	Do not need analog reference if choose this control mode
n.□□0□	Internal set speed control ⇔ Speed control	These are switching methods that you can use to change between two of the above four control methods. You can select the combination that is required for the application
n.□□0□	Internal set speed control ⇔ Position control	
n.□□0□	Internal set speed control ⇔ Torque control	
n.□□0□	Position control ⇔ Speed control	
n.□□0□	Position control ⇔ Torque control	
n.□□0□	Torque control ⇔ Speed control	
n.□□0□	Speed control ⇔ speed control with zero clamping	
n.□□0□	Position control ⇔ position control with reference pulse inhibition	You can use reference pulse inhibition for position control.

4.3

## Automatic Detection of Connected Motor

You can use a SERVOPACK to operate either a Rotary Servomotor or a Linear Servomotor. If you connect the Servomotor encoder to the CN2 connector on the SERVOPACK, the SERVOPACK will automatically determine which type of Servomotor is connected. Therefore, you normally do not need to specify the motor type.

4.4 Functions and Settings for the /S-ON (Servo ON) Signal

4.4.1 Functions for the /S-ON (Servo ON) Signal

**4.4** Functions and Settings for the /S-ON (Servo ON) Signal

The /S-ON (Servo ON) signal is used to enable Servomotor operation. This section describes the function of and settings for the /S-ON signal.

4.4.1 Functions for the /S-ON (Servo ON) Signal

Type	Signal	Connector Pin No.	Signal Status	Function
Input	/S-ON	CN1-40 (default setting)	ON (closed)	Power is supplied to the Servomotor to enable operation.
			OFF (open)	Power supply to the Servomotor is stopped and operation is disabled.

You can use Pn50A = n.□□X□ (/S-ON (Servo ON) Signal Allocation) to allocate the /S-ON signal to a different input signal terminal. Refer to the following section for details on input signal allocation.



**Important**

- Always input the /S-ON signal before you input a speed, position, or torque reference to start the Servomotor. Never input the reference first and then use the /S-ON signal or turn ON the AC power supply to start the Servomotor. Doing so will degrade internal elements and may cause an accident.
- Input the /S-ON signal while the Servomotor is stopped. You cannot turn ON the servo while the Servomotor is operating.

4.4.2 Setting to Keep the Servo ON and Supply Power to the Motor Continuously

You can set Pn50A = n.yyXy (/S-ON (Servo ON) Signal Allocation) to 7 (The signal is always active) to keep the servo ON and supply power to the motor continuously.

Parameter	Meaning	When enabled	Classification
Pn50A	n.□□0□ Default setting	After reset	Setup
	n.□□7□		



**Important**

- If you set this parameter to keep the servo ON continuously, power will be supplied to the motor as soon the main circuit power supply to the SERVOPACK is turned ON. If there is already a speed, position, or torque reference input, the Servomotor or machine may perform unexpected operation. Always implement safety measures.
- If a resettable alarm occurs and operation is disabled (power is not supplied to the motor), operation will be automatically enabled (power will be supplied to the motor) when the alarm is reset. If you set this parameter to keep the servo ON continuously, the Servomotor or machine may perform unexpected operation when an alarm is reset.

## Motor Direction Setting

You can reverse the direction of Servomotor rotation by changing the setting of Pn000 = n□□□X (Direction Selection) without changing the polarity of the speed or position reference. This causes the rotation direction of the motor to change, but the polarity of the signals, such as encoder output pulses, output from the SERVOPACK do not change. Set the appropriate direction for your system.

The default setting for forward rotation is counterclockwise (CCW) as viewed from the load end of the Servomotor.

Parameter		Forward/Reverse Reference	Motor Direction and Encoder Divided Pulse Outputs		Applicable Overtravel Signal (OT)
Pn000	n□□□0 Use CCW as the forward direction. (default setting)	Forward reference		Encoder Divided Pulse Outputs PAO Phase-A lead PBO Phase-B lead	P-OT (Forward Drive Prohibit) signal
		Reverse reference		Encoder Divided Pulse Outputs PAO Phase-A lead PBO Phase-B lead	N-OT (Reverse Drive Prohibit) signal
	n□□□1 Use CW as the forward direction. (Reverse Rotation Mode)	Forward reference		Encoder Divided Pulse Outputs PAO Phase-A lead PBO Phase-B lead	P-OT (Forward Drive Prohibit) signal
		Reverse reference		Encoder Divided Pulse Outputs PAO Phase-A lead PBO Phase-B lead	N-OT (Reverse Drive Prohibit) signal

## 4.6 Overtravel and Related Settings

### 4.6.1 Overtravel Signals

4.6

## Overtravel and Related Settings

Overtravel is a function of the SERVOPACK that forces the Servomotor to stop in response to a signal input from a limit switch that is activated when a moving part of the machine exceeds the safe range of movement.

The overtravel signals include the P-OT (Forward Drive Prohibit) and the N-OT (Reverse Drive Prohibit) signals.

You use the P-OT and N-OT signals to stop the machine by installing limit switches at the positions where you want to stop the machine that is operated by the Servomotor.

A SERVOPACK wiring example is provided below.

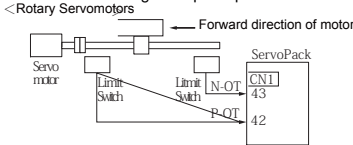

Using the overtravel function is not necessary for rotating applications such as rotary tables and conveyors. No wiring for over travel input signals is required.

This section describes the parameter settings related to the overtravel.

### ⚠ Cautions

To prevent accidents that may result from contact faults or disconnections, use normally closed limit switches.  
Do not change the default settings of the polarity of the overtravel signals (P-OT and N-OT).

### 4.6.1 Overtravel Signals

The overtravel signals include the P-OT (Forward Drive Prohibit) and the N-OT (Reverse Drive Prohibit) signals.

Type	Signal	Conector Pin No.	Signal Status	Meaning
Input	P-OT	CN1-42	ON	Forward drive is enabled (actual operation).
			OFF	Forward drive is prohibited.(Forward overtravel)
	N-OT	CN1-43	ON	Reverse drive is enabled (actual operation).
			OFF	Reverse drive is prohibited.(Reverse overtravel)

You can operate the Servomotor in the opposite direction during overtravel by inputting a reference..



When the Servomotor stops due to overtravel during position control, the position deviation is held.

You must input the CLR (Clear) signal to clear the position deviation. Refer to the following section for information on the CLR signal.

### 4.6.2 Setting to Enable/Disable Overtravel

You can use Pn50A = n.X□□□ (P-OT (Forward Drive Prohibit) Signal Allocation) and Pn50B = n.□□□ X (N-OT (Reverse Drive Prohibit) Signal Allocation) to enable and disable the overtravel function.

You do not need to wire the overtravel input signals if you are not going to use the overtravel function.

	Parameter	Meaning	When enabled	Classification
Pn50A	n.2□□□ [ Factory Setting ]	The forward overtravel function is enabled and the P-OT (Forward Drive Prohibit) signal is input from CN3-9.	After restart	Setup
	n.8□□□	The forward overtravel function is disabled. Forward drive is always enabled.		
Pn50B	n.□□□3 [ Factory setting ]	The reverse overtravel function is enabled and the N-OT (Reverse Drive Prohibit) signal is input from CN3-9.	After restart	
	n.□□□8	The reverse overtravel function is disabled. Reverse drive is always enabled.		

## 4.7

## Holding Brake

A holding brake is used to hold the position of the moving part of the machine when the SERVOPACK is turned OFF so that moving part does not move due to gravity or an external force.

You can use the brake that is built into a Servomotor with a Brake, or you can provide one on the machine. The holding brake is used in the following cases.

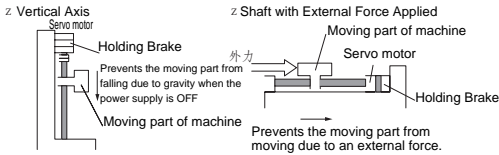

Important

The brake built into a Servomotor with a Brake is a de-energization brake. It is used only to hold the Servomotor and cannot be used for braking. Use the holding brake only to hold a Servomotor that is already stopped.

## 4.7.1

## Brake Operating Sequence

You must consider the time required to release the brake and the time required to brake to determine the brake operation timing, as described below.



Terms

**Time Required to Release Brake**

The time from when the /BK (Brake) signal is turned ON until the brake is actually released.

**Time Required to Brake**

The time from when the /BK (Brake) signal is turned OFF until the brake actually operates.

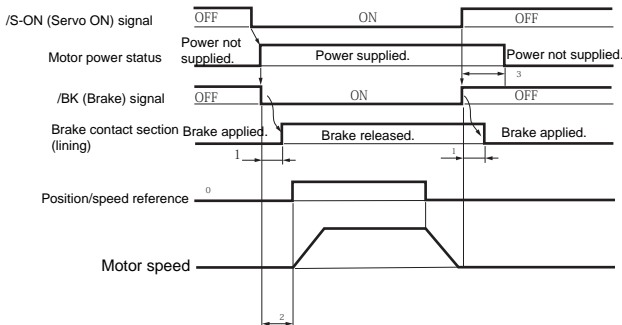

4.7.2 /BK (Brake) Signal

The following settings are for the output signal that controls the brake. The /BK (Brake) signal is not allocated by default. To use the brake, change the setting of Pn50F = n□ X□□ /BK (Brake Output) Signal Allocation).

The /BK signal is turned OFF (to operate the brake) when the servo is turned OFF or when an alarm is detected. You can adjust the timing of brake operation (i.e., the timing of turning OFF the /BK signal) with the servo OFF delay time (Pn506).

Type	Signal	Connector Pin No.	Signal Status	Meaning
Output	/BK	Must be allocated.	ON (closed)	Releases the brake.
			OFF (open)	Activates the brake.

Information: The /BK signal will remain ON during overtravel. The brake will not be applied.

4.7.3 Output Timing of /BK (Brake) Signal When the Servomotor Is Stopped

When the Servomotor is stopped, the /BK signal turns OFF at the same time as the /S-ON signal turns OFF. Use the servo OFF delay time (Pn506) to change the timing to turn OFF power supply to the motor after the /S-ON signal turns OFF.

Pn506	Brake Reference-Servo OFF Delay Time			Speed	Position	Torque
	Setting Range	Setting Unit	Default Setting	When Enabled	Classification	
	0 ~ 50	10ms	0	Immediately	Setup	

1. When the Servomotor is used to control a vertical axis, the machine moving part may move slightly due to gravity or an external force. You can eliminate this slight motion by setting the servo OFF delay time (Pn506) so that power supply to the motor is stopped after the brake is applied.

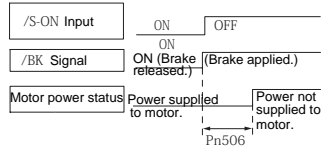

2. This parameter sets the timing of stopping power supply to the Servomotor while the Servomotor



**Important** Power supply to the Servomotor will be stopped immediately when an alarm occurs, regardless of the setting of this parameter. The machine moving part may move due to gravity or an external force before the brake is applied.

## 4.7.4

## Output Timing of /BK (Brake) Signal When the Servomotor Is Operating

If an alarm occurs while the Servomotor is operating, the Servomotor will start stopping and the /BK signal will be turned OFF. You can adjust the timing of /BK signal output by setting the brake reference output speed level (Rotary Servomotors: Pn507, Linear Servomotors: Pn583) and the Servo OFF-Brake Command Waiting Time (Pn508).

Note: If zero-speed stopping is set as the stopping method for alarms, the setting of Pn506 (Brake Reference-Servo OFF Delay Time) is used after the motor stops.

Pn507	Brake Reference Output Speed Level			Speed	Position	Torque
	Setting Range	Setting Unit	Default Setting	When Enabled	Classification	
	0 ~ 10000	1mm <sup>1</sup>	100	Immediately	Setup	
Pn508	Servo OFF-Brake Command Waiting Time			Speed	Position	Torque
	Setting Range	Setting Unit	Default Setting	When Enabled	Classification	
	10 ~ 100	10ms	50	Immediately	Setup	

The brake operates when either of the following conditions is satisfied:

When the Motor Speed Goes below the Level Set in Pn507 after the Power Supply to the Motor Is Stopped

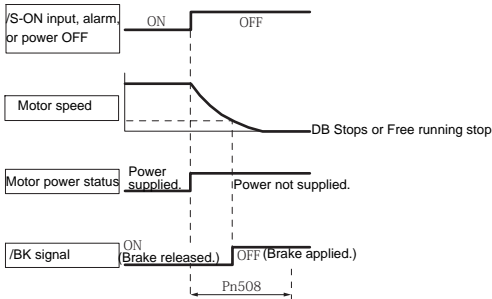

When the Time Set In Pn508 Elapses after the Power Supply to the Motor Is Stopped

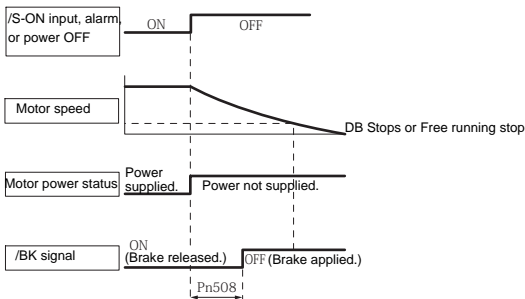

The Servomotor will be limited to its maximum speed even if the brake reference output speed level ( Pn507) is higher than the maximum speed.

Important

## 4.8 Stopping Method for Servo OFF

Stopping method for servo OFF as followings

Stopping method for servo motor	Meaning
Dynamic brake (DB) Stop	Make electric loop of servo motor short circuit, to make servo motor stop emergently
Free-running stop	Naturally stop by the friction when motor rotating

 Dynamic Brake(DB) is the function of emergency stop. If through power ON/OFF or execute run/stop by Servo ON under entering command status, DB loop will operate frequently, it will cause servopack inner component burn-in. Please execute servo motor run or stop by entering speed command or position command

**Important**

## 4.9 Electronic Gear Settings

The minimum unit of the position data that is used to move a load is called the reference unit. The reference unit is used to give travel amounts, not in pulses, but rather in distances or other physical units (such as  $\mu\text{m}$  or  $^\circ$ ) that are easier to understand. The electronic gear is used to convert the travel distances that are specified in reference units to pulses, which are required for actual movements.

With the electronic gear, one reference unit is equal to the workpiece travel distance per reference pulse input to the SERVOPACK. In other words, if you use the SERVOPACK's electronic gear, pulses can be read as reference units.

Note: 1. If you set an electronic gear in the host controller, normally set the electronic gear ratio in the SERVOPACK to 1:1.

2. If you enable reference pulse input multiplication switching, the reference unit is defined as the position data that is n times the reference pulses input from the host controller. ("n" is the reference pulse input multiplier.)

The difference between using and not using the electronic gear is shown below.

### Absolute servo motor

In this example, the following machine configuration is used to move the workpiece 10 mm.

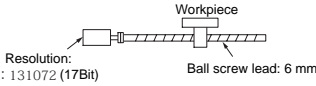

#### When the Electronic Gear Is Not Used

- To move a workpiece 10 mm:
1. Calculate the number of revolutions.  
so 10/6 revolutions are required to move 10 mm.
  2. Calculate the required number of reference pulses.  
One revolution is 131072 pulses, therefore  
 $10/6 \times 131072 = 218453.333$  pulses.
  3. Input 218453 pulses as the reference.

Calculating the number of reference pulses for each reference is troublesome.



#### When the Electronic Gear Is Used

- If you use reference units to move the workpiece when one reference unit is set to 1  $\mu\text{m}$ , the travel distance is 1  $\mu\text{m}$  per pulse.  
To move the workpiece 10 mm (10,000  $\mu\text{m}$ ),  $10,000 \div 1 = 10,000$  pulses, so 10,000 pulses would be input.

Calculating the number of reference pulses for each reference is not necessary.

## 4.9.1 Electronic Gear Ratio Settings

Set the electronic gear ratio using Pn20E and Pn210.



The setting range of the electronic gear as follows  
 $0.001 < \text{Electronic gear ratio (B/A)} < 64,000$   
If the electronic gear ratio is outside of this range, an A.040 alarm (Parameter Setting Error) will occur.

Important

Pn20E	Electronic Gear Ratio (Numerator)				Position
	Setting Range	Setting Unit	Default Setting	When Enabled	Classification
	1 ~ 1073741824	1	64	After restart	Setup
Pn210	Electronic Gear Ratio (Denominator)				Position
	Setting Range	Setting Unit	Default Setting	When Enabled	Classification
	1 ~ 1073741824	1	1	After restart	Setup

### Calculating the Settings for the Electronic Gear Ratio

If the gear ratio between the Servomotor shaft and the load is given as n/m, where n is the number of load rotations for m Servomotor shaft rotations, the settings for the electronic gear ratio can be calculated as follows:

$$\text{Electronic gear ratio} = \frac{B}{A} = \frac{Pn20E}{Pn210} = \frac{\text{Encoder resolution}}{\text{Travel distance per load shaft revolution (reference units)}} \times \frac{m}{n}$$

4.9 Electronic Gear Ratio Setting

4.9.2 Electronic Gear Ratio Setting Examples

4.9.2 Electronic Gear Ratio Setting Examples

Setting examples are provided in this section.

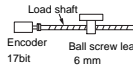
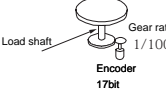
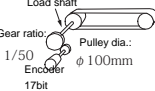
Step	Description	Machine Configuration		
		Ball Screw	Rotary Table	Belt and Pulley
		Reference unit: 0.001mm  Load shaft Encoder 17bit Ball screw lead: 6 mm	Reference unit: 0.01°  Load shaft Encoder 17bit Gear ratio: 1/100	Reference unit: 0.005mm  Load shaft Encoder 17bit Pulley dia.: φ 100mm Gear ratio: 1/50
1	Machine Specifications	Ball screw lead: 6mm Gear ratio: / 1	Rotation angle per revolution: 360° Gear ratio: 1/100	Pulley dia.: 100 mm (Pulley circumference: 314 mm) Gear ratio: 1/50
2	Encoder Resolution	131072 (17 bit)	131072 (17Bit)	131072 (17Bit)
3	Reference unit:	0.001mm (1μm)	0.01°	0.005mm (5μm)
4	Travel Distance per Load Shaft Revolution (Reference Units)	6mm/0.001mm = 6000	360°/0.01° = 36000	314mm/0.005mm = 62800
5	Electronic Gear Ratio	$\frac{B}{A} = \frac{131072}{6000} \times \frac{1}{1}$	$\frac{B}{A} = \frac{131072}{36000} \times \frac{100}{1}$	$\frac{B}{A} = \frac{131072}{62800} \times \frac{50}{1}$
6	Parameters	Pn20E : 131072	Pn20E : 13107200	Pn20E : 6553600
		Pn210 : 6000	Pn210 : 36000	Pn210 : 62800

## Resetting the Absolute Encoder

In a system that uses an absolute encoder, the multiturn data must be reset at startup. An alarm related to the absolute encoder (A.810 or A.820) will occur when the absolute encoder must be reset, such as when the power supply is turned ON.

When you reset the absolute encoder, the multiturn data is reset and any alarms related to the absolute encoder are cleared.

Reset the absolute encoder in the following cases.

- 1 When starting the system for the first time
- 2 When an A.810 alarm (Encoder Backup Alarm) occurs
- 3 When an A.820 alarm (Encoder Checksum Alarm) occurs
- 4 When you want to reset the multiturn data in the absolute encoder

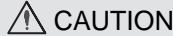

### CAUTION

The multiturn data will be reset to a value between -2 and +2 rotations when the absolute encoder is reset. The reference position of the machine system will change. Adjust the reference position in the host controller to the position that results from resetting the absolute encoder. If the machine is started without adjusting the position in the host controller, unexpected operation may cause personal injury or damage to the machine.

The multiturn data will always be zero in the following cases. It is never necessary to reset the absolute encoder in these cases.

#### Information

- 1 When you use a single-turn absolute encoder
  - 2 When the encoder is set to be used as a single-turn absolute encoder (Pn002 = n.  2  )
- Also, an alarm related to the absolute encoder (A.810 or A.820) will not occur.

### 4.10.1 Precautions on Resetting

1. You cannot use the /ALM-RST (Alarm Reset) signal from the SERVOPACK to clear the A.810 alarm (Encoder Backup Alarm) or the A.820 alarm (Encoder Checksum Alarm). Always use the operation to reset the absolute encoder to clear these alarms.

2. If an A.8\*\* alarm (Internal Encoder Monitoring Alarm) occurs, turn OFF the power supply to reset the alarm.

### 4.10.2 Preparations

Always check the following before you reset an absolute encoder.

1. The parameters must not be write prohibited.
2. The servo must be OFF.

### 4.10.3 Applicable Tools

The following table lists the tools that you can use to reset the absolute encoder and the applicable

Tool	Function	Reference
Panel Operator	Fn013	Press "M/SET" until appears "Done"

# Maintenance



This chapter provides information on the meaning of, causes of, and corrections for alarms and warnings.

<b>5.1</b>	<b>Inspections and Part Replacement .....</b>	<b>5-2</b>
5.1.1	Inspections .....	5-2
5.1.2	Guidelines for Part Replacement .....	5-2
5.1.3	Replacing the Battery .....	5-3
<b>5.2</b>	<b>Alarm Displays .....</b>	<b>5-4</b>
5.2.1	List of Alarms .....	5-4
5.2.2	Troubleshooting Alarms .....	5-5
5.2.3	Resetting Alarms .....	5-10
5.2.4	Displaying the Alarm History .....	5-10
<b>5.3</b>	<b>Troubleshooting Based on the Operation and Conditions of the Servomotor....</b>	<b>5-11</b>

## 5.1 Inspections and Part Replacement

This section describes inspections and part replacement for SERVOPACKs.

### 5.1.1 Inspections

Perform the inspections given in the following table at least once every year for the SERVOPACK. Daily inspections are not required.

Item	Frequency	Inspection	Correction
Exterior	At least once a year	Check for dust, dirt, and oil on the surfaces.	Clean with compressed air or a cloth.
Loose Screws		Check for loose terminal block and connector screws and for other loose parts.	Tighten any loose screws or other loose parts.

### 5.1.2 Guidelines for Part Replacement

The following electric or electronic parts are subject to mechanical wear or deterioration over time. Use one of the following methods to check the standard replacement period.

Use the following table.

Part	Standard Replacement Period	Remarks
Cooling Fan	4 to 5 years	The standard replacement periods given on the left are for the following operating conditions. 1. Surrounding air temperature: Annual average of 30°C 2. Load factor: 80% max. 3. Operation rate: 20 hours/day max.
Electrolytic Capacitor	10 years	
Relays	100,000 power ON operations	Power ON frequency: Once an hour
Battery	3 years without power supplied	Surrounding temperature without power supplied: 20°C



Important

The parameters of any SERVOPACKs that are sent to YuHai for part replacement are reset to the factory settings before they are returned to you. Always keep a record of the parameter settings. And, always confirm that the parameters are properly set before starting operation.

### 5.1.3 Replacing the Battery

If the battery voltage drops to approximately 2.7 V or less, an A.830 alarm (Encoder Battery Alarm) or an A.930 warning (Absolute Encoder Battery Error) will be displayed.

If this alarm or warning is displayed, the battery must be replaced.

Refer to the following section for the battery replacement procedure.

#### Battery Replacement Procedure

##### When Installing a Battery on the Host Controller

1. Turn ON only the control power supply to the SERVOPACK.
2. Remove the old battery and mount a new battery.
3. Turn OFF the control power supply to the SERVOPACK to clear the A.830 alarm (Encoder Battery Alarm).
4. Turn ON the control power supply to the SERVOPACK again.
5. Make sure that the alarm has been cleared and that the SERVOPACK operates normally.

◆ When Using an Encoder Cable with a Battery Case

1. Turn ON only the control power supply to the SERVOPACK



If you remove the Battery or disconnect the Encoder Cable while the control power supply to the SERVOPACK is OFF, the absolute encoder data will be lost.

2. Open the cover of the Battery Case.

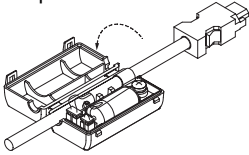

3. Remove the old Battery and mount a new Battery.

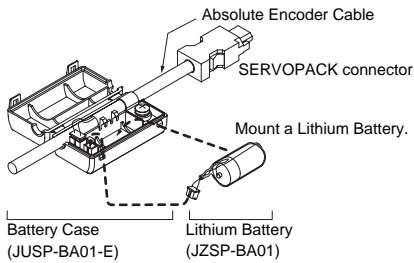

4. Close the cover of the Battery Case.

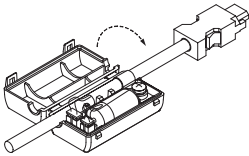

5. Turn OFF the power supply to the SERVOPACK to clear the A.830 alarm (Encoder Battery Alarm).
6. Turn ON the power supply to the SERVOPACK.
7. Make sure that the alarm has been cleared and that the SERVOPACK operates normally.

## List of Alarms

If an error occurs in the SERVOPACK, an alarm number will be displayed on the panel display.



An alarm number flashes on the display.

This section provides a list of the alarms that may occur and the causes of and corrections for those alarms.

## List of Alarms

The list of alarms gives the alarm name, alarm meaning, alarm stopping method, alarm reset possibility, and alarm code output in order of the alarm numbers.

### Alarm Reset Possibility

**Yes:** You can use an alarm reset to clear the alarm. However, this assumes that the cause of the alarm has been removed.

**No:** You cannot clear the alarm.

Alarm Number	Alarm Name	Alarm Meaning	Alarm Reset Possible?
020	Parameter Checksum Error	There is an error in the parameter data in the SERVOPACK.	NO
040	Parameter Setting Error	A parameter setting is outside of the setting range.	NO
050	Combination Error	The capacities of the SERVOPACK and Servomotor do not match	YES
055	Motor model Error	Driver parameter is not matching with motor	YES
100	Overcurrent Detected	An overcurrent flowed through the power transistor or the heat sink overheated	NO
105	Driver Overheat Error	Inner IPM too hot	NO
300	Regeneration Error	There is an error related to regeneration.	YES
320	Regenerative Overload	A regenerative overload occurred.	YES
400	Overvoltage	The main circuit DC voltage is too high.	YES
410	Undervoltage	The main circuit DC voltage is too low.	YES
510	Overspeed	The motor exceeded the maximum speed.	YES
720	Continuous Overload	The Servomotor was operating continuously under a torque that exceeded the rating.	YES
810	Encoder Backup Alarm	The power supplies to the encoder all failed and the position data was lost.	NO
820	Encoder Checksum Alarm	There is an error in the checksum results for encoder memory.	NO
840	Encoder Data Alarm	There is an internal data error in the encoder.	NO
830	Encoder Battery Alarm	The battery voltage was lower than the specified level after the control power supply was turned ON.	NO
850	Encoder Overspeed	The encoder was operating at high speed when the power was turned ON.	NO
870	Encoder Absolute Status Error	Encoder broken or encoder decode circuit broken	NO
871	Encoder Count Error	Encoder broken or encoder decode circuit broken	NO
b10	Speed Reference A/D Error	An error occurred in the A/D converter for the speed reference input.	YES
b40	First Channel Current Detection Abnormal	Current Detection Abnormal	NO
b41	Second Channel Current Detection Abnormal	Current Detection Abnormal	NO
bF2	System Alarm 1	Internal program error 1 occurred in the SERVOPACK.	NO
C90	Encoder Communications Error	Communications between the encoder and SERVOPACK is not possible.	NO
C97	Encoder A B C Wire Broken	Encoder do not connect or wire welding problem	NO
C98	Encoder U V W Wire Broken	Encoder do not connect or wire welding problem	NO
CC0	Multiturn Limit Disagreement	Encoder multi-turn information error	NO
C80	Encoder multi-turn information flow	Encoder multi circle information flow	NO
Cb0	Encoder Echoback Error	The contents of communications with the encoder are incorrect.	NO
Cb1	Encoder Checksum Error	Encoder signal disturbed or encoder decode circuit broken	YES
Cb2	Encoder State-domain Cut-off Position Error	Encoder signal disturbed or encoder decode circuit broken	YES
Cb3	Encoder SFOME Cut-off Position Error	Encoder signal disturbed or encoder decode circuit broken	YES
C99	U,V,W illegal code	U V W signal too high or too low	YES
C9A	U,V,W phase angle error	U V W signal too high or too low	YES
d00	Position Deviation Overflow	The setting of Position Deviation Overflow Alarm Level was exceeded by the position deviation while the servo was ON.	YES
d30	Position Data Overflow	The position feedback data exceeded limited level	NO
E80	MODBUS Communication overtime	Driver do not receive the data in the setted time of Pn012	YES
E81	CANopen heartbeat overtime	Driver do not receive the heartbeat in setted time	YES

## 5.2.2 Troubleshooting Alarms

The causes of and corrections for the alarms are given in the following table. Contact your Yuhai representative if you cannot solve a problem with the correction given in the table.

Alarm Number: Alarm Name	Possible Cause	Confirmation	Correction
A.020: Parameter Checksum Error (There is an error in the parameter data in the SERVOPACK.)	The power supply voltage suddenly dropped.	Measure the power supply voltage.	Set the power supply voltage within the specified range, and initialize the parameter settings.
	The power supply was shut OFF while writing parameter settings	Check the timing of shutting OFF the powersupply.	Initialize the parameter settings and then set the parameters again.
	The number of times that parameters were written exceeded the limit.	Check to see if the parameters were frequently changed from the host controller.	The SERVOPACK may be faulty. Replace the SERVOPACK. Reconsider the method for writing the parameters
	A malfunction was caused by noise from the AC power supply, ground, static electricity, or other source.	Turn the power supply to the SERVOPACK OFF and ON again.If the alarm still occurs, noise may be the cause.	Implement countermeasures against noise.
	Gas, water drops, or cutting oil entered the SERVOPACK and caused failure of the internal components.	Check the installation conditions.	The SERVOPACK may be faulty. Replace the SERVOPACK.
	A failure occurred in the SERVOPACK.	Turn the power supply to the SERVOPACK OFF and ON again.If the alarm still occurs, the SERVOPACK may have failed.	The SERVOPACK may be faulty. Replace the SERVOPACK.
A.040: Parameter Setting Error (A parameter setting is outside of the setting range.)	The capacity of motor and driver do not match	Check the capacity of motor and driver	Make motor and driver capacity match
	A failure occurred in the SERVOPACK.	-	Maybe driver faulty Change new one
	A parameter setting is outside of the setting range.	Check the setting ranges of the parameters that have been changed.	Set the parameters to values within the setting ranges.
	The electronic gear ratio is outside of the setting range.	Check The ratio must be within the following range: $0.001 < (Pn20E/Pn210) < 64,000$ .	Set the electronic gear ratio in the following range: $0.001 < (Pn20E/Pn210) < 64,000$ .
A.050: Combination Error (The capacities of the SERVOPACK and Servomotor do not match.)	Motor and driver not match	Check Motor and driver match or not	Make motor and driver match
	A failure occurred in the encoder.	Replace the encoder and check to see if the alarm still occurs.	Change servo motor(encoder)
	A failure occurred in the SERVOPACK.	-	The SERVOPACK may be faulty. Replace the SERVOPACK.
A.100: Overcurrent Detected (An overcurrent flowed through the power transistor or the heat sink overheated.)	The Main Circuit Cable is not wired correctly	Check the wiring	Correct the wiring
	There is a short-circuit or ground fault in a Main Circuit Cable.	Check for short-circuits phases U,V, and W, or between the ground and Servomotor phases U V and W.	The cable may be shortcircuited. Replace the cable.
	There is a short-circuit or ground fault inside the Servomotor.	Check for short-circuits phases U,V, and W, or between the ground and Servomotor phases U V and W.	The Servomotor may be faulty. Replace the Servomotor.
	There is a short-circuit or ground fault inside the Servomotor	Check for short-circuits phases U,V, and W, or between the ground and Servomotor phases U V and W.	The Servomotor may be faulty. Replace the Servomotor.
	The regenerative resistor is not wired correctly	Check the wiring	Correct the wiring
	The regenerative processing capacity was exceeded.		
	The SERVOPACK regenerative resistance is too small.		Change the regenerative resistance to a value larger than the SERVOPACK minimum allowable resistance.
	A heavy load was applied while the Servomotor was stopped or running at a low speed.	Check to see if the operating conditions exceed Servo Drive specifications.	Reduce the load applied to the Servomotor Or increase the operating speed.
	A malfunction was caused by noise	Improve the noise environment, e.g. by improving the wiring or installation conditions, and check to see if the alarm still occurs.	Implement countermeasures against noise, such as correct wiring of the FG. Use an FG wire size equivalent to the SERVOPACK's main circuit wire size.
	A failure occurred in the SERVOPACK.	-	Turn the power supply to the SERVOPACK OFF and ON again. If an alarm still occurs, the SERVOPACK may be faulty. Replace the SERVOPACK.

Continued from previous page.

Alarm Number: Alarm Name	Possible Cause	Confirmation	Correction
A.300: Regeneration Error	The jumper between the regenerative resistor terminals (B2 and B3) was removed	Check to see if the jumper is connected between power supply terminals B2 and B3.	Correctly connect a jumper
	The External Regenerative Resistor is not wired correctly, or was removed or disconnected	Check the wiring of the External Regenerative Resistor.	Correct the wiring of the External Regenerative Resistor.
	A failure occurred in the SERVOPACK.	-	While the main circuit power supply is OFF, turn the control power supply to the SERVOPACK OFF and ON again. If an alarm still occurs, the SERVOPACK may be faulty. Replace the SERVOPACK
A.320: Regenerative Overload	The power supply voltage exceeded the specified range.	Measure the power supply voltage.	Set the power supply voltage within the specified range.
	The external regenerative resistance value or regenerative resistor capacity is too small, or there has been a continuous regeneration state.	-	Change the regenerative resistance value or capacity.
	There was a continuous regeneration state because a negative load was continuously applied.	Check the load applied to the Servomotor during operation.	Reconsider the system including the servo, machine, and operating conditions.
	The external regenerative resistance is too high.	Check the regenerative resistance.	Change the regenerative resistance to a correct value or use an External Regenerative Resistor of an appropriate capacity
	A failure occurred in the SERVOPACK	-	The SERVOPACK may be faulty. Replace the SERVOPACK
A.400: Overvoltage (Detected in the main circuit power supply section of the SERVOPACK.)	The power supply voltage exceeded the specified range.	-	Set the AC/DC power supply voltage within the specified range.
	The power supply is not stable or was influenced by a lightning surge.	Measure the power supply voltage.	Improve the power supply conditions, install a surge absorber, and then turn the power supply OFF and ON again. If an alarm still occurs, the SERVOPACK may be faulty. Replace the SERVOPACK.
	The external regenerative resistance is too high for the operating	Check the operating conditions and the regenerative resistance	Select a regenerative resistance value that is appropriate for the operating conditions and load
	The moment of inertia ratio or mass ratio exceeded the allowable value.	Check to see if the moment of inertia ratio or mass ratio is within the allowable range.	Increase the deceleration time, or reduce the load.
	A failure occurred in the SERVOPACK.	-	Restart the servopack under main circuit is OFF. If alarm still occurs, maybe problem of driver, need to change new one
A.410: Undervoltage (Detected in the main circuit power supply section of the SERVOPACK.)	The power supply voltage lower than the specified range.	Measure the power supply voltage.	Set the power supply voltage within the specified range.
	The power dropped when operating	Measure the power supply voltage.	Increase the power supply capacity.
	A momentary power interruption occurred	-	If you have changed the setting of Pn509, decrease the setting.
	The SERVOPACK fuse is blown out.	-	Replace the servopack
A failure occurred in the SERVOPACK.	-	The SERVOPACK may be faulty. Replace the SERVOPACK.	
A.510: Overspeed (The motor exceeded the maximum speed.)	Motor U V W wiring incorrect	Check servo motor wiring	Confirm motor wiring correct or not
	Reference value exceed the overspeed detection level	Check the input reference	Reduce the reference value. Or, adjust the gain.
	The motor exceeded the maximum speed.	Check the waveform of the motor speed.	Reduce the speed reference input gain and adjust the servo gain. Or, reconsider the operating conditions.
A failure occurred in the SERVOPACK.	-	The SERVOPACK may be faulty. Replace the SERVOPACK.	
A.720 : Continuous Overload	The wiring is not correct in the motor or encoder wiring.	Check wiring	Confirm wiring correct or not
	Operation was exceeded the overload protection characteristics.	Check the motor overload characteristics and Run command.	Reconsider the load and operating conditions. Or, increase the motor capacity.
	An excessive load was applied during operation because the Servomotor was not driven due to mechanical problems.	Check the operation reference and motor speed.	Correct the mechanical problem.
A failure occurred in the SERVOPACK.	-	The SERVOPACK may be faulty. Replace the SERVOPACK.	

Alarm Number: Alarm Name	Possible Cause	Confirmation	Correction
A.810: Encoder Backup Alarm (Detected at the encoder, but only when an absolute encoder is used.)	The power to the absolute encoder was turned ON for the first time.	Check to see if the power supply was turned ON for the first time.	Set up the encoder
	The Encoder Cable was disconnected and then connected again.	Check to see if the power supply was turned ON for the first time.	Check the encoder connection and set up the encoder.
	Power is not being supplied both from the control power supply (+5 V) from the SERVOPACK and from the battery power supply.	Check the encoder connector battery and the connector status.	Replace the battery or implement similar measures to supply power to the encoder, and set up the encoder.
	A failure occurred in the absolute encoder	—	If the alarm still occurs after setting up the encoder again, replace the Servomotor.
A.820: Encoder Checksum Alarm (Detected at the encoder.)	A failure occurred in – the encoder.	—	Reset the encoder.If Alarm still occurs maybe need to change the servo motor
	A failure occurred in the SERVOPACK.	—	The SERVOPACK may be faulty. Replace the SERVOPACK.
A.830: Encoder Battery Alarm (The absolute 5 encoder battery voltage was lower than the specified level.)	The battery connection is faulty or a battery is not connected	Check the battery connection	Correct the battery connection.
	The battery voltage is lower than the specified value (2.7 V).	Measure the battery voltage.	Replace the battery.
	A failure occurred in the SERVOPACK.	—	The SERVOPACK may be faulty. Replace the SERVOPACK.
A.840: Encoder Data Alarm (Detected at the encoder.)	The encoder malfunctioned.	—	Restart the servopack, If an alarm still occurs,the Servomotor or linear encoder may be faulty. Replace the Servomotor or linear encoder
	Malfunction the encoder by Noise	—	Correct the encoder external wiring
A.850: Encoder Overspeed (Detected at the encoder when the control power supply is turned ON.)	The Servomotor speed was 200 min-1 or higher when the control power ON.	Check the motor speed when the power supply is turned ON.	Reduce the Servomotor speed to a value less than 200 min-1, and turn ON the control power supply.
	A failure occurred in the encoder.	—	Restart the servopack, If an alarm still occurs,the Servomotor or linear encoder may be faulty. Replace the Servomotor or linear encoder
	A failure occurred in the SERVOPACK.	—	Restart the SERVOPACK again. If an alarm still occurs, the SERVOPACK may be faulty. Replace the SERVOPACK.
A.b10: Speed Reference A/D Error (Detected when the servo is turned ON.)	A malfunction occurred in the speed reference input section.	—	Reset the alarm and restart operation.
	A failure occurred in the SERVOPACK.	—	Restart the SERVOPACK again. If an alarm still occurs, the SERVOPACK may be faulty. Replace the SERVOPACK.
A.bF2: System Alarm 2	A failure occurred in the SERVOPACK.	—	Restart the SERVOPACK again. If an alarm still occurs, the SERVOPACK may be faulty. Replace the SERVOPACK.
A.C80: Encoder Clear Error or Multiturn Limit Setting Error	A failure occurred in the encoder.	—	Restart the servopack, If an alarm still occurs,the Servomotor or linear encoder may be faulty. Replace the Servomotor or linear encoder
	A failure occurred in the SERVOPACK.	—	Restart the SERVOPACK again. If an alarm still occurs, the SERVOPACK may be faulty. Replace the SERVOPACK.

Alarm Number: Alarm Name	Possible Cause	Confirmation	Correction
A.C90: Encoder Communications Error	There is a faulty contact in the connector or the connector is not wired correctly for the encoder.	Check the condition of the encoder connector	Reconnect the encoder connector and check the encoder wiring.
	There is a cable disconnection or shortcircuit in the encoder. Or, the cable impedance is outside the specified values.	Check the condition of the Encoder Cable.	Use the Encoder Cable within the specified specifications.
	One of the following has occurred: corrosion caused by improper temperature, humidity, or gas, a short-circuit caused by entry of water drops or cutting oil, or faulty contact in connector caused by vibration.	Check the operating environment.	Improve the operating environmental, and replace the cable. If the alarm still occurs, replace the SERVOPACK.
	A malfunction was caused by noise.	-	Correct the wiring around the encoder by separating the Encoder Cable from the Servomotor Main Circuit Cable or by grounding the encoder.
	A failure occurred in the SERVOPACK.	-	Connect the Servomotor to another SERVOPACK, and turn ON the control power supply. If no alarm occurs, the SERVOPACK may be faulty. Replace the SERVOPACK.
A.C97 : Encoder A B C Signal Error	Encoder cable clamped or damaged	Check the status of cable and connector	Check encoder cable laying ok or not
	Check whether encoder cable binging with high current cable or too close	Check encoder cable setting status	Lay the encoder cable in the postion which do not influence by surge voltage
	A failure occurred in the SERVOPACK.		Change servopack or servo motor
A.C98 : Encoder U V W Signal Error	Faulty contact in connector	-	Power off and re-plug-in connector
	Too Much Vibration On Encoder	Check operating status	Lower machine vibration Correctly install servo motor
	A failure occurred in encoder	-	Restart the power,if still alarm maybe problem of servo motor. Need to change new motor
	A failure occurred in the SERVOPACK.	-	Restart the power,if still alarm maybe problem of servopack. Need to change new servopack

## 5.2 Alarm Displays

### 5.2.2 Troubleshooting Alarms

Alarm Number: Alarm Name	Possible Cause	Confirmation	Correction
A.Cb0: Encoder Echoback Error	The encoder is wired incorrectly or there is faulty contact.	Check the wiring of the encoder.	Make sure that the encoder is correctly wired.
	The specifications of the Encoder Cable are not correct and noise entered on it.	—	Use a shielded twistedpair wire cable or a screened twisted-pair cable with conductors of at least 0.12 mm <sup>2</sup> .
	The Encoder Cable is too long and noise entered on it.	—	The Encoder Cable wiring distance must be 50m max.
	There is variation in the FG potential because of the influence of machines on the Servomotor side, such as a welder	Check the condition of the Encoder Cable and connectors.	Properly ground the machine to separate it from the FG of the encoder.
	Excessive vibration or shock was applied to the encoder.	Check the operating conditions.	Reduce machine vibration. Correctly install the Servomotor
	A failure occurred in encoder	—	Restart the power,if still alarm maybe problem of servo motor. Need to change new motor
	<b>A failure occurred in the SERVOPACK.</b>	— —	<b>Restart the power,if still alarm maybe problem of servopack. Need to change new servopack</b>
A.CC0: Multiturn Limit Disagreement	Absolute encoder Multi-turn abnormal	—	Execute Fn013 and Fn014
Absolute encoder Multi-turn data flow	Absolute encoder Data Abnormal	—	Execute Fn013 and Fn014
A.d00: Position Deviation Overflow (The setting of Pn504 (Position Deviation Overflow Alarm Level) was exceeded by the position deviation while the servo was ON.)	The Servomotor U, V, and W wiring is not correct.	Check the wiring of the Servomotor's Main Circuit Cables	Make sure that there are no faulty contacts in the wiring for the Servomotor and encoder.
	The frequency of the position reference pulse is too high.	Reduce the reference pulse frequency and try operating the SERVOPACK.	Reduce the position reference pulse frequency or the reference acceleration rate, or reconsider the electronic gear ratio.
	The acceleration of the position reference is too high.	Reduce the reference acceleration and try operating the SERVOPACK.	Apply smoothing, i.e., by using Pn216 (Position Reference Acceleration/Deceleration Time Constant).
	The setting of Pn504 (Position Deviation Overflow Alarm Level) is too low for the operating conditions.	Check Pn504 (Position Deviation Overflow Alarm Level) to see if it is set to an appropriate value.	Optimize the setting of Pn504
<b>A failure occurred in the SERVOPACK.</b>	— —	<b>Restart the power,if still alarm maybe problem of servopack. Need to change new servopack</b>	
A.d30: Position Data Overflow	The position data exceeded $\pm 1,879,048,192$ .	Check the input reference pulse counter.	Reconsider the operating specifications.

### 5.2.3 Resetting Alarms

If there is an ALM (Servo Alarm) signal, use one of the following methods to reset the alarm after eliminating the cause of the alarm.  
The /ALM-RST (Alarm Reset) signal will not always reset encoder-related alarms. If you cannot reset an alarm with the /ALM-RST signal, turn OFF the control power supply to reset it.



Important

Be sure to eliminate the cause of an alarm before you reset the alarm.  
If you reset the alarm and continue operation without eliminating the cause of the alarm, it may result in damage to the equipment or fire

#### Resetting Alarms with the /ALM-RST (Alarm Reset Input) Signal

Type	Signal	Connector Pin No.	Name
Input	/ALM-RST	CN3-4	Alarm Reset

Note: Use Pn50B = n.□□X □ (/ALM-RST (Alarm Reset) Signal Allocation) to allocate the /ALM-RST signal to other connector pins. Refer to the following section for details.

#### Resetting Alarms Using the Panel Operator

Simultaneously press the UP and the DOWN Keys on the Panel Operator.

### 5.2.4 Displaying the Alarm History

The alarm history displays up to the last ten alarms that have occurred in the SERVOPACK.

#### Preparations

No preparations are required.

#### Applicable Tools

The following table lists the tools that you can use to display the alarm history and the applicable tool functions.

Tool	Function	Reference
Panel Operator	Fn000	Press UP and DOWN after entering

**5.3 Troubleshooting Based on the Operation and Conditions of the Servomotor**

This section provides troubleshooting based on the operation and conditions of the Servomotor, including causes and corrections.  
 Turn OFF the Servo System before troubleshooting the items shown in bold lines in the table.

Problem	Possible Cause	Confirmation	Correction
Servomotor Does Not Start	The control power supply is not turned ON.	Measure the voltage between control power supply terminals.	Correct the wiring so that the control power supply is turned ON.
	The main circuit power supply is not turned ON.	Measure the voltage between the main circuit power input terminals.	Correct the wiring so that the main circuit power supply is turned ON
	The I/O signal connector (CN3) pins are not wired correctly or are disconnected.	Check the wiring condition of the I/O signal connector (CN3) pins.	Correct the wiring of the I/O signal connector (CN1) pins.
	The wiring for the Servomotor Main Circuit Cables or Encoder Cable is disconnected.	Check the wiring conditions.	Wire the cable correctly.
	There is an overload on the Servomotor.	Operate the Servomotor with no load and check the load status.	Reduce the load or replace the Servomotor with a Servomotor with a larger capacity.
	The type of encoder that is being used does not agree with the setting of Pn002 = n.□□□□(Encoder Usage).	Check the type of the encoder that is being used and the setting of Pn002 = n.□□□□.	Set Pn002 = n.□□□□ according to the type of the encoder that is being used.
	No speed or position reference is input.	Check the allocation status of the input signals.	Allocate an input signal so that the speed and position references are input correctly.
	A mistake in the input signal allocations Pn50A	Check the input signal allocations Pn50A	Correctly allocate the input signals Pn50A
	The /S-ON (Servo ON) signal is OFF.	Check the settings of Pn50A = n.□□□□X (Input Signal Allocation Mode) and Pn50A = n.□□□□ /S-ON (Servo ON) Signal	Allocation). Set Pn50A = n.□□□□X correctly and turn ON the /S-ON signal.
	The function setting of the / P-CON (Proportional Control) signal is not correct.	Check the setting of Pn000 = n.□□□□ (Control Method Selection).	Set the parameter to match the application.
	The SEN input is OFF.	Check the ON/OFF status of the SEN input.	If you are using an absolute encoder, turn ON the SEN signal.
	The reference pulse mode selection is not correct.	Check the setting of Pn200 = n.□□□□X (Reference Pulse Form) and the reference pulse form.	Set Pn200 = n.□□□□X so that it agrees with the reference pulse form.
	Speed control: The speed reference input is not appropriate.	Check between the speed reference input (VREF) and signal ground to see if the control method and the input agree.	Correctly set the control method and input method.
	Torque control: The torque reference input is not appropriate.	Check between the torque reference input (TREF) and signal ground to see if the control method and the input agree.	Correctly set the control method and input method.
Position control: The reference pulse input is not appropriate.	Check the setting of Pn200 = n.□□□□X (Reference Pulse Form) and the sign and pulse signals.	Correctly set the control method and input method.	
The /CLR (Position Deviation Clear) input signal has not been turned OFF.		Turn OFF the /CLR signal.	

C

Problem	Possible Cause	Confirmation	Correction
Servomotor Does Not Start	The P-OT (Forward Drive Prohibit) or N-OT (Reverse Drive Prohibit) signal is still OFF.	Check the P-OT and NOT signals.	Turn ON the P-OT and N-OT signals.
	A failure occurred in the SERVOPACK.		Replace the SERVOPACK.
Servomotor Moves Instantaneously, and Then Stops	There is a mistake in the Servomotor wiring.	Check the wiring.	Wire the Servomotor correctly.
	There is a mistake in the wiring of the encoder or Serial Converter Unit.	Check the wiring.	Wire the Serial Converter Unit correctly.
Servomotor Speed Is Unstable	There is a faulty connection in the Servomotor wiring.	The connector connections for the power line (U, V, and W phases) and the encoder or Serial Converter Unit may be unstable. Check the wiring.	Tighten any loose terminals or connectors or correct the wiring.
Servomotor Moves without a Reference Input	Speed control: The speed reference input is not appropriate.	Check between the speed reference input (VREF) and signal ground to see if the control method and the input agree.	Correctly set the control method and input method.
	Torque control: The torque reference input is not appropriate.	Check between the torque reference input (TREF) and signal ground to see if the control method and the input agree.	Correctly set the control method and input method.
	The speed reference offset is not correct.	The SERVOPACK offset is adjusted incorrectly.	Adjust the SERVOPACK offset.
	Position control: The reference pulse input is not appropriate.	Check the setting of Pn200 = n. □□□ X (Reference Pulse Form) and the sign and pulse signals.	Correctly set the control method and input method.
	A failure occurred in the SERVOPACK.	—	Replace the SERVOPACK.

### 5.3 Troubleshooting Based on the Operation and Conditions of the Servomotor

Problem	Possible Cause	Confirmation	Correction
Servomotor Abnormal Noise from	The Servomotor vibrated considerably while performing the tuning-less function with the default settings.	Check the waveform of the motor speed.	Reduce the load so that the moment of inertia ratio or mass ratio is within the allowable value, or increase the load level or reduce the rigidity level in the tuning-less level settings.
	The machine mounting is not secure.	Check to see if there are any loose mounting screws.	Tighten the mounting screws.
	The machine mounting is not secure.	Check to see if there is misalignment in the coupling.	Align the coupling.
		Check to see if the coupling is balanced.	Balance the coupling.
	The bearings are defective.	Check for noise and vibration around the bearings.	Replace the Servomotor.
	There is a vibration source at the driven machine.	Check for any foreign matter, damage, or deformation in the machine's moving parts	Consult with the machine manufacturer
	Noise interference occurred because of incorrect I/O signal cable specifications.	Check the I/O signal cables to see if they satisfy specifications. Use shielded twisted-pair cables or screened twisted-pair cables with conductors of at least 0.12 mm <sup>2</sup> (stranded wire).	Use cables that satisfy the specifications
	Noise interference occurred because an I/O signal cable is too long.	Check the lengths of the I/O signal cables.	The I/O signal cables must be no longer than 3 m.
	Noise interference occurred because of incorrect Encoder Cable specifications.	Check the Encoder Cable to see if it satisfies specifications. Use shielded twisted-pair cables or screened twisted-pair cables with conductors of at least 0.12 mm <sup>2</sup> (stranded wire).	Use cables that satisfy the specifications.
	Noise interference occurred because the Encoder Cable is too long.	Check the length of the Encoder Cable.	Rotary Servomotors: The Encoder Cable length must be 50 m max.
	Noise interference occurred because the Encoder Cable is damaged.	Check the Encoder Cable to see if it is pinched or the sheath is damaged.	Replace the Encoder Cable and correct the cable installation environment.
	The Encoder Cable was subjected to excessive noise interference.	Check to see if the Encoder Cable is bundled with a high-current line or installed near a high-current line.	Correct the cable layout so that no surge is applied by high-current lines.
	There is variation in the FG potential because of the influence of machines on the Servomotor side, such as a welder	Check to see if the machines are correctly grounded.	Properly ground the machines to separate them from the FG of the encoder.
There is a SERVOPACK pulse counting error due to noise.	Check to see if there is noise interference on the signal line from the encoder.	Implement countermeasures against noise for the encoder wiring.	
The encoder was subjected to excessive vibration or shock.	Check to see if vibration from the machine occurred. Check the Servomotor installation (mounting surface precision, securing state, and alignment).	Reduce machine vibration. Improve the mounting state of the Servomotor or linear encoder	

Problem	Possible Cause	Confirmation	Correction
Servomotor Vibrates at Frequency of Approx. 200 to 400Hz.	The servo gains are not balanced.	Check to see if the servo gains have been correctly tuned.	Perform autotuning without a host reference.
	The setting of Pn100 (Speed Loop Gain) is too high.	Check the setting of Pn100. The default setting is $K_v = 40.0$ Hz.	Set Pn100 to an appropriate value.
	The setting of Pn102 (Position Loop Gain) is too high.	Check the setting of Pn102. The default setting is $K_p = 40.0/s$ .	Set Pn102 to an appropriate value.
	The setting of Pn101 (Speed Loop Integral Time Constant) is not appropriate.	Check the setting of Pn101. The default setting is $T_i = 20.0$ ms.	Set Pn101 to an appropriate value.
	The setting of Pn103 (Moment of Inertia Ratio or Mass Ratio) is not appropriate.	Check the setting of Pn103.	Set Pn103 to an appropriate value.
Large Motor Speed Overshoot on Starting and Stopping	The servo gains are not balanced.	Check to see if the servo gains have been correctly tuned.	Perform autotuning without a host reference.
	The setting of Pn100 (Speed Loop Gain) is too high.	Check the setting of Pn100. The default setting is $K_v = 40.0$ Hz.	Set Pn100 to an appropriate value.
	The setting of Pn102 (Position Loop Gain) is too high.	Check the setting of Pn102. The default setting is $K_p = 40.0/s$ .	Set Pn102 to an appropriate value.
	The setting of Pn101 (Speed Loop Integral Time Constant) is not appropriate.	Check the setting of Pn101. The default setting is $T_i = 20.0$ ms.	Set Pn101 to an appropriate value.
	The setting of Pn103 (Moment of Inertia Ratio or Mass Ratio) is not appropriate.	Check the setting of Pn103.	Set Pn103 to an appropriate value.
	The torque reference is saturated.	Check the waveform of the torque reference.	Use the mode switch.

### 5.3 Troubleshooting Based on the Operation and Conditions of the Servomotor

Problem	Possible Cause	Confirmation	Correction
Absolute Encoder Position Deviation Error (The position that was saved in the host controller when the power was turned OFF is different from the position when the power was next turned ON.	Noise interference occurred because of incorrect Encoder Cable specifications.	Check the Encoder Cable to see if it satisfies specifications. Use shielded twisted-pair cables or screened twisted-pair cables with conductors of at least 0.12 mm <sup>2</sup> (stranded wire).	Use cables that satisfy the specifications.
	Noise interference occurred because the Encoder Cable is too long.	Check the length of the Encoder Cable.	1.Absolute Servomotors: The Encoder Cable length must be 50 m max. 2.Incremental Servomotors: Cable are no longer than 15 m each.
	Noise interference occurred because the Encoder Cable is damaged.	Check the Encoder Cable to see if it is pinched or the sheath is damaged.	Replace the Encoder Cable and correct the cable installation environment.
	The Encoder Cable was subject to excessive noise interference. Check to see if the	Encoder Cable is bundled with a high-current line or installed near a high-current line.	Correct the cable layout so that no surge is applied by high-current lines.
	The Encoder Cable was subject to excessive noise interference.	Check to see if the Encoder Cable is bundled with a high-current line or installed near a high-current line.	Correct the cable layout so that no surge is applied by high-current lines.
	There is a SERVOPACK pulse counting error due to noise.	Check to see if there is noise interference on the I/O signal line from the encoder or Serial Converter Unit.	Implement countermeasures against noise for the encoder or Serial Converter Unit wiring.
	The encoder was subjected to excessive vibration or shock.	Check to see if vibration from the machine occurred. Check the Servomotor installation (mounting surface precision, securing state, and alignment). Check the linear encoder installation (mounting surface precision and securing method).	Reduce machine vibration. Improve the mounting state of the Servomotor.
	A failure occurred in the encoder.		Replace the Servomotor
	A failure occurred in the SERVOPACK.	-	Replace the SERVOPACK.
	Host Controller Multiturn Data or Absolute Encoder Position Data Reading Error		Check the error detection section of the host controller.
		Check to see if the host controller is executing data parity checks.	Perform parity checks for the multiturn data or absolute encoder position data.
		Check for noise interference in the cable between the SERVOPACK and the host controller.	Implement countermeasures against noise and then perform parity checks again for the multiturn data or absolute encoder position data.

Problem	Possible Cause	Confirmation	Correction
Overtravel Occurred	The P-OT/N-OT (Forward Drive Prohibit or Reverse Drive Prohibit) signal was input.	Check the external power supply (+24 V) voltage for the input signals.	Correct the external power supply (+24 V) voltage for the input signals.
		Check the operating condition of the overtravel limit switches.	Make sure that the overtravel limit switches operate correctly.
		Check the wiring of the overtravel limit switches.	Correct the wiring of the overtravel limit switches.
		Check the settings of the overtravel input signal allocations (Pn50A/ Pn50B).	Set the parameters to correct values.
	The P-OT/N-OT (Forward Drive Prohibit or Reverse Drive Prohibit) signal malfunctioned.	Check for fluctuation in the external power supply (+24 V) voltage for the input signals.	Eliminate fluctuation from the external power supply (+24 V) voltage for the input signals.
		Check to see if the operation of the overtravel limit switches is unstable.	Stabilize the operating condition of the overtravel limit switches.
		Check the wiring of the overtravel limit switches (e.g., check for cable damage and loose screws).	Correct the wiring of the overtravel limit switches.
	There is a mistake in the allocation of the P-OT or N-OT (Forward Drive Prohibit or Reverse Drive Prohibit) signal in Pn50A = n.X□□□ or Pn50B = n.□□□X.	Check to see if the P-OT signal is allocated in Pn50A = n.X□□□ .	If another signal is allocated in Pn50A = n.X□□□ , allocate the P-OT signal instead.
		Check to see if the N-OT signal is allocated in Pn50B = n.□□□X.	If another signal is allocated in Pn50B = n.□□□X, allocate the N-OT signal instead.
	Improper Stop Position for Overtravel (OT) Signal	The limit switch position and dog length are not appropriate.	
The overtravel limit switch position is too close for the coasting distance.			Install the overtravel limit switch at the appropriate position.

### 5.3 Troubleshooting Based on the Operation and Conditions of the Servomotor

Problem	Possible Cause	Confirmation	Correction
Position Deviation (without Alarm)	Noise interference occurred because of incorrect Encoder	Cable specifications. Check the Encoder Cable to see if it satisfies specifications. Use shielded twisted-pair cables or screened twisted-pair cables with conductors of at least 0.12 mm <sup>2</sup> (stranded wire).	Use cables that satisfy the specifications.
	Noise interference occurred because the Encoder Cable is too long.	Check the length of the Encoder Cable.	The Encoder Cable length must be 50 m max.
	Noise interference occurred because the Encoder Cable is damaged.	Check the Encoder Cable to see if it is pinched or the sheath is damaged.	Replace the Encoder Cable and correct the cable installation environment.
	The Encoder Cable was subjected to excessive noise interference.	Check to see if the Encoder Cable is bundled with a high-current line or installed near a high-current line.	Correct the cable layout so that no surge is applied by high-current lines.
	There is variation in the FG potential because of the influence of machines on the Servomotor side, such as a welder.	Check to see if the machines are correctly grounded.	Properly ground the machines to separate them from the FG of the encoder.
	There is a SERVOPACK pulse counting error due to noise.	Check to see if there is noise interference on the I/O signal line from the encoder or Serial Converter Unit.	Implement countermeasures against noise for the encoder wiring or Serial Converter Unit wiring.
	The encoder was subjected to excessive vibration or shock.	Check to see if vibration from the machine occurred. Check the Servomotor installation (mounting surface precision, securing state, and alignment). Check the linear encoder installation (mounting surface precision and securing method).	Reduce machine vibration. Improve the mounting state of the Servomotor or linear encoder.
	The coupling between the machine and Servomotor is not suitable.	Check to see if position offset occurs at the coupling between machine and Servomotor.	Correctly secure the coupling between the machine and Servomotor
	Noise interference occurred because of incorrect I/O signal cable specifications.	Check the I/O signal cables to see if they satisfy specifications. Use shielded twisted-pair cables or screened twisted-pair cables with conductors of at least 0.12 mm <sup>2</sup> (stranded wire).	Use cables that satisfy the specifications.
	Noise interference occurred because an I/O signal cable is too long. An encoder fault occurred. (The pulse count does not change.) A failure occurred in the SERVOPACK.	Check the lengths of the I/O signal cables. –	The I/O signal cables must be no longer than 3 m. Replace the Servomotor or linear encoder. Replace the SERVOPACK.
Servomotor Overheated	The surrounding air temperature is too high.	Measure the surrounding air temperature around the Servomotor.	Reduce the surrounding air temperature to 40°C or less.
	The surface of the Servomotor is dirty.	Visually check the surface for dirt.	Clean dirt, dust, and oil from the surface.
	There is an overload on the Servomotor.	Check the load status with a monitor.	If the Servomotor is overloaded, reduce the load or replace the Servo Drive with a SERVOPACK and Servomotor with larger capacities

# Panel Displays and Panel Operator Procedures



This chapter describes how to interpret panel displays and the operation of the Panel Operator.

<b>6.1</b>	<b>Panel Operator</b> .....	<b>6-2</b>
	6.1.1 Panel Operator Key Names and Functions .....	6-2
	6.1.2 Changing Modes .....	6-2
	6.1.3 Status Displays .....	6-3
<b>6.2</b>	<b>Parameter (Pn□□□) Operations on the Panel Operator</b> .....	<b>6-4</b>
	6.2.1 Setting Parameters That Require Numeric Settings .....	6-4
	6.2.2 Setting Parameters That Require Selection of Functions .....	6-5
<b>6.3</b>	<b>Monitor Display (Un) Operations on the Panel Operator</b> .....	<b>6-6</b>
	6.3.1 Basic Monitor Display Operations .....	6-6
	6.3.2 Input Signal Monitor (Un005) .....	6-7
	6.3.3 Output Signal Monitor (Un006) .....	6-8
<b>6.4</b>	<b>Utility Function (Fn) Operations on the Panel Operator</b> .....	<b>6-9</b>
	6.4.1 Display Alarm History (Fn000) .....	6-9
	6.4.2 Jog (Fn002) .....	6-10
	6.4.3 Initialize Parameters (Fn005) .....	6-10
	6.4.4 Autotune Analog (Speed/Torque) Reference Offset (Fn009) .....	6-11
	6.4.5 Manually Adjust Speed Reference Offset (Fn00A) .....	6-11
	6.4.6 Manually Adjust Torque Reference Offset (Fn00B) .....	6-12
	6.4.7 Display Servomotor Model (Fn011) .....	6-12
	6.4.8 Display Software Version (Fn012) .....	6-13
	6.4.9 Multiturn Limit Setting after Multiturn Limit Disagreement Alarm (Fn013) .....	6-13



### 6.1.3 Status Displays

The status is displayed as described below.

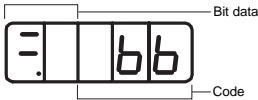

#### Interpreting Bit Data

Display	Meaning
	<b>Control Power ON Display</b> Lit while the SERVOPACK control power is ON. Not lit if the SERVOPACK control power is OFF.
	<b>Base Block Display</b> Lit if the servo is OFF. Not lit while the servo is ON.
	<b>During Speed Control: /V-CMP (Speed Coincidence Detection) Signal Display</b> Lit if the difference between the Servomotor speed and the reference speed is the same as or less than the setting of Pn503 or Pn582. (The default setting is 10 min-1 or 10 mm/s.) Always lit during torque control. Additional Information If there is noise in the reference voltage during speed control, the horizontal segment (-) on the top of the leftmost digit on the Panel Operator display may flash. Refer to the following section and implement countermeasures against noise. 4.1.2 Countermeasures against Noise on page 4-5
	<b>During Position Control: /COIN (Positioning Completion) Signal Display</b> Lit if the deviation between the position reference and actual motor position is equal to or less than the setting of Pn522. (The default setting is 7 reference units.) Not lit if the deviation exceeds the setting.
	<b>/TGON (Rotation Detection) Signal Display</b> Lit if the Servomotor speed is higher than the setting of Pn502 or Pn581 and not lit if the speed is lower than the setting. (The default setting is 20 min-1 or 20 mm/s.)
	<b>During Speed Control: Speed Reference Input Display</b> Lit if the current input reference is larger than the setting of Pn502 or Pn581 and not lit if the reference is smaller than the setting. (The default setting is 20 min-1 or 20 mm/s.) <b>During Position Control: Reference Pulse Input Display</b> Lit while reference pulses are being input. Not lit if reference pulses are not being input.
	<b>During Torque Control: Torque Reference Input Display</b> Lit if the current input torque reference is larger than the specified value (10% of the rated torque) and not lit if the reference is smaller than the specified value. <b>During Position Control: Clear Signal Input Display</b> Lit while the clear signal is being input. Not lit if the clear signal is not being input.
	<b>Power Ready Display</b> Lit while the main circuit power supply is ON. Not lit if the main circuit power supply is OFF.

#### Interpreting Codes

Display	Meaning
	<b>Base Block Active</b> Indicates that the servo is OFF.
	<b>Operation in Progress</b> Indicates that the servo is ON.
	<b>Forward Drive Prohibited</b> Indicates that the P-OT (Forward Drive Prohibit) signal is open.
	<b>Reverse Drive Prohibited</b> Indicates that the N-OT (Reverse Drive Prohibit) signal is open.
	<b>Alarm Status</b> Flashes the alarm number.

## Parameter (Pn□□□) Operations on the Panel Operator

This section describes the procedures for setting the parameters that are used in this manual. Refer to the following sections for details on parameter classifications and notation.

### 6.2.1 Setting Parameters That Require Numeric Settings

The following procedure shows how to change the setting of Pn100 (Speed Loop Gain) from 400 to 1000 as an example of a parameter that requires a numeric setting.

Step	Panel Display after Operation	Keys	Operation
1			Press the MODE/SET Key to enter Parameter Setting Mode. If Pn100 is not displayed, press the UP Key or DOWN Key to display Pn100.
2			Press the DATA/SHIFT Key for approximately one second. The current setting of Pn100 will be displayed.
3			Press the DATA/SHIFT Key to move the digit that is flashing to "4". (You can change the value of the digit that is flashing.)
4			Press the UP Key six times to change the setting to 1000. Refer to the following section for the operating procedure for settings with more than five digits.
5			Press the MODE/SET Key. The display will flash. The setting has now been changed from 400 to 1000.
			Press the DATA/SHIFT Key for approximately one second to return the display to Pn100.

- Information** **Setting Negative Numbers**
- 1 For parameters that accept a negative setting, display 00000 and then press the DOWN Key to set a negative number.
  - 2 For a negative number, the value increases when the DOWN Key is pressed and decreases when the UP Key is pressed.

#### Parameters with Settings of More Than Five Digits

The Panel Operator displays five digits. Settings of more than five digits are displayed as shown in the following figure.

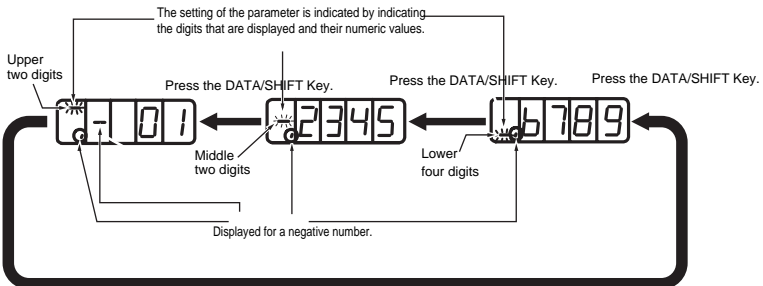

## 6.2.2 Setting Parameters That Require Selection of Functions

For parameters that require selection of functions, you can select the individual digits of the numbers displayed on the Panel Operator to set the functions assigned to them.

The following example shows how to change the setting of Pn000 = n. □□X□ (Control Method Selection) in Pn000 (Basic Function Selections 0) from speed control to position control.

Step	Panel Display after Operation	Keys	Operation
1			Press the <b>MODE/SET</b> key to enter Parameter setting Mode. If Pn000 is not displayed, press the <b>UP</b> Key or <b>DOWN</b> Key to display Pn000
2			Press the <b>DATA/SHIFT</b> key for approximately one second. The current setting of Pn000 will be displayed.
3			Press the <b>DATA/SHIFT</b> Key to move the digit that is flashing. (You can change the value of the digit that is flashing.)
4			Press the <b>UP</b> key once to change the display to n.0010. (This changes the control method from speed control to position control.)
5	 (Flashing)		Press the <b>MODE/SET</b> key . The display will flash The control method has now been changed from speed control to position control.
6			Press the <b>DATA/SHIFT</b> key for approximately one second. Pn000 is displayed again.
7	To enable the change to the setting, turn the power supply to the SERVO PACK OFF and ON again		

6.3.1 Basic Monitor Display Operations

# 6.3 Motor Display (Un□□□) Operations on the Panel Operator

You can monitor the status of the reference values and I/O signals that are set in the SERVO-PACK and the internal status of the SERVOPACK with monitor displays.

The Panel Operator displays numbers beginning with “Un.”

Display Example for Motor Speed



This section describes the basic operations for monitor displays and how to interpret some special monitor displays.

Refer to the following section for details on the contents of the monitor display.

## 6.3.1 Basic Monitor Display Operations

The procedure for Un000(Motor Speed) is described here as an example

Step	Panel Display after Operation	Keys	Operation
1			Press the MODE/SET key to enter Monitor Display Mode.
2			Press the UP key or DOWN key to select the Un , number of the item that you want to monitor.
3			Press the DATA/SHIT key for approximately one second.
4			Press the DATA/SHIT key for approximately one second. The display shown for step 1 will appear again.

### The list of servo unit Monitor function display

Un No.	Name (Unit)
Un000	Motor speed (min-1)
Un001	Speed command (min-1)
Un002	Torque command(%)(The value setted when the rated torque is 100%)
Un004	Rotation angle-deg (Electrical angle from the angle of the origin of the magnetic pole )
Un005	Input signal Monitor
Un006	Output signal Monitor
Un007	Only effective in position while input pulse command speed (min-1)
Un008	Only effective in position control while Position deviation-command unit
Un00C	Input pulse command accouter" command unit '
Un013	Feedback pulse accouter "command unit '
Un040	The position of absolute encoder in 1 circle (encoder pulse)
Un041	The rotations datasheet of absolute encoder
Un150	Bus voltage

## 6.3.2 Input Signal Monitor (Un005)

You can use Un005 to display the status of allocated signals on the LED segments of the Panel Operator.

### ◆ Interpreting the Display

LED Segments

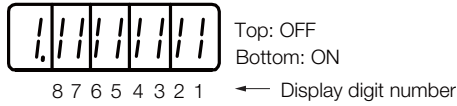

- If the input signal that corresponds to the display digit number is OFF, the top LED segment will be lit.
- If the input signal that corresponds to the display digit number is ON, the bottom LED segment will be lit.

The allocations are given in the following table.

Display Digit Number	Input Pin Number	Signal Name (Default Setting)
1	CN3-7	/SI0 (/S-ON)
2	CN3-8	/SI3 (/P-CON)
3	CN3-9	/SI1 (P-OT)
4	CN3-39	/SI2 (N-OT)
5	CN3-25	/SI4 (/ALM-RST)
6	CN3-26	/SI5 (/P-CL)
7	CN3-41	/SI6 (/N-CL)
8	CN3-30	SEN

#### Information

The configuration of the input circuits is shown below.

OFF: Open  
ON: Closed  
Example:

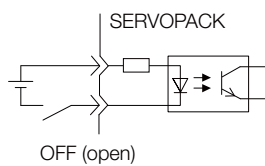

### ◆ Display Examples

Display examples for input signals are shown below.

- When the /S-ON (Servo ON) Signal Is ON

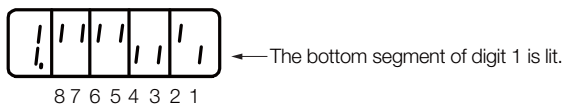

- When the /S-ON (Servo ON) Signal Is OFF

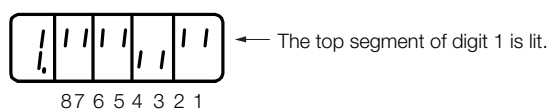

- When the P-OT (Forward Drive Prohibit) Signal Is Active

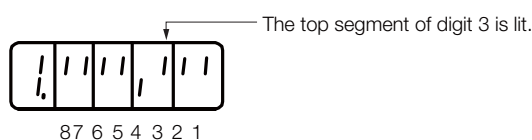

### 6.3.3 Output Signal Monitor (Un006)

You can use Un006 to display the status of allocated signals on the LED segments of the Panel Operator.

#### ◆ Interpreting the Display

LED Segments

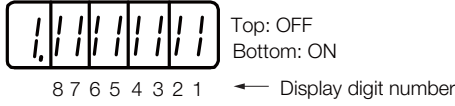

- If the output signal that corresponds to the display digit number is OFF, the top LED segment will be lit.
- If the output signal that corresponds to the display digit number is ON, the bottom LED segment will be lit.

The allocations are given in the following table.

Display Digit Number	Output Pin Numbers	Signal Name (Default Setting)
1	CN3-5 and CN3-20	ALM+, CALM-
2	CN1-25 and CN1-26	/SO1+ (/COIN+ or /V-CMP+) and /SO1- (/COIN- or /V-CMP-)
3	CN3-22 and CN3-37	/SO2+ (/TGON+) /SO2- (/TGON-)
4	CN3-23 and CN3-38	/SO3+ (/S-RDY+) /SO3- (/S-RDY-)
5		Reserved.
6		Reserved.
7		Reserved.
8	-	Reserved.

**Information**

The configuration of the output circuits is shown below.

OFF: Transistor OFF  
 ON: Transistor ON  
 Example:

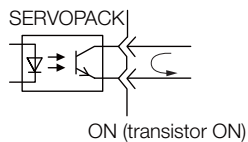

#### ◆ Display Examples

A display example for output signals is shown below.

- When the ALM (Servo Alarm) Signal Is OFF

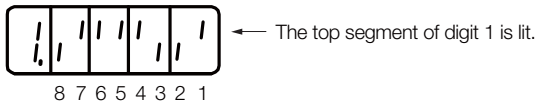

## 6.4 Utility Function (Fn□□□) Operations on the Panel Operator

Utility functions are used to set up and tune the SERVOPACK.

The Panel Operator displays numbers beginning with “Fn.”

**Display example:**

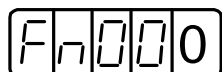

The operating procedures from the Panel Operator are described here. Refer to the descriptions of individual utility functions for preparations and related parameters.

Refer to the following section for details on utility functions.

15.2.1 Corresponding SERVOPACK Utility Function Names on page 15-7

### 6.4.1 Display Alarm History (Fn000)

Refer to the following section for information on this utility function other than the procedure.

Step	Panel Display after Operation	Keys	Operation
1			Press the <b>MODE/SET</b> Key to enter Utility Function Mode. If <b>Fn000</b> is not displayed, press the <b>UP</b> Key or <b>DOWN</b> Key to display <b>Fn000</b> .
2			Press the <b>DATA/SHIFT</b> Key for approximately one second. The most recent alarm will be displayed.
3			Press the <b>DOWN</b> Key to display the next older alarm. Press the <b>UP</b> Key to display the next newer alarm. The higher the far-left segment is, the older the alarm is.

The list of servo unit function

Fn No.	Name
Fn00	The display of alarm record
Fn002	The running of JOG
Fn005	The Parameter setting value initialization
Fn009	The auto adjustment of analog value (speed .torque)commond offset
Fn00A	The hand adjustment of speed commond offset
Fn00B	The hand adjustment of torque commond offset
Fn011	Display motor modle
Fn012	Display software version
Fn013	Clear the Multi circle information of absolute encoder
Fn014	Clear the error of absolute encoder

## 6.4.2 Jog (Fn002)

Refer to the following section for information on this utility function other than the procedure.

Step	Panel Display after Operation	Keys	Operation
1			Press the <b>MODE/SET</b> Key to enter Utility Function Mode.
2			Press the <b>UP</b> Key or <b>DOWN</b> Key to display <b>Fn002</b> .
3			Press the <b>DATA/SHIFT</b> Key for approximately one second. The display shown at the left will appear.
4			Press the <b>MODE/SET</b> Key to turn ON the servo.
5			The Servomotor will operate at the speed set in Pn304 or Pn383 while the <b>UP</b> Key (for forward operation) or <b>DOWN</b> Key (for reverse operation) is pressed.
6			Press the <b>MODE/SET</b> Key to turn OFF the servo. Additional Information You can turn OFF the servo by pressing the <b>DATA/SHIFT</b> Key for approximately one second.
7			Press the <b>DATA/SHIFT</b> Key for approximately one second to return the display to <b>Fn002</b> .
8	Turn the power supply to the SERVOPACK OFF and ON again after you finish jogging.		



## 6.4.3 Initialize Parameters (Fn005)

Refer to the following section for information on this utility function other than the procedure.

Step	Panel Display after Operation	Keys	Operation
1			Press the <b>MODE/SET</b> Key to enter Utility Function Mode.
2			Press the <b>UP</b> Key or <b>DOWN</b> Key to display <b>Fn005</b> .
3			Press the <b>DATA/SHIFT</b> Key for approximately one second. The display shown at the left will appear.
4			Press the <b>MODE/SET</b> Key to initialize the parameters. When the initialization has been completed, <b>donE</b> will flash on the display, and then the display shown on the left will appear again.
5	To enable the change to the setting, turn the power supply to the SERVOPACK OFF and ON again after the initialization of the parameter settings has been completed.		



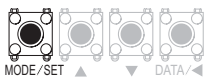
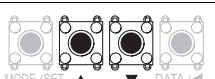
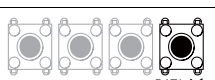

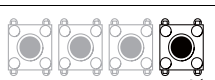
## 6.4.4 Autotune Analog (Speed/Torque) Reference Offset (Fn009)

Refer to the following section for information on this utility function other than the procedure.

Step	Panel Display after Operation	Keys	Operation
1	-	-	Turn OFF the servo, and input a 0-V reference voltage from the host controller or an external circuit.
2	Fn000		Press the <b>MODE/SET</b> Key to enter Utility Function Mode.
3	Fn009		Press the <b>UP</b> Key or <b>DOWN</b> Key to display <b>Fn009</b> .
4	rEF_o		Press the <b>DATA/SHIFT</b> Key for approximately one second. <b>rEF_o</b> will be displayed.
5	rEF_o		Press the <b>MODE/SET</b> Key. <b>donE</b> will flash on the display for approximately one second, and then the display shown on the left will appear.
6	Fn009		Press the <b>DATA/SHIFT</b> Key for approximately one second to return the display to <b>Fn009</b> .

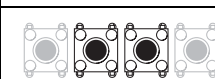
## 6.4.5 Manually Adjust Speed Reference Offset (Fn00A)

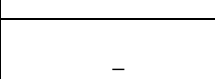
Refer to the following section for information on this utility function other than the procedure.

Step	Panel Display after Operation	Keys	Operation
1	Fn000		Press the <b>MODE/SET</b> Key to enter Utility Function Mode.
2	Fn00A		Press the <b>UP</b> Key or <b>DOWN</b> Key to display <b>Fn00A</b> .
3	r.SPd		Press the <b>DATA/SHIFT</b> Key for approximately one second. The display shown on the left will appear. Note: If write protection is set, <b>no_oP</b> will flash on the display for approximately one second. Change the setting of Fn010 to enable writing.
4	r.SPd	-	Turn ON the servo from an external device. The display shown on the left will appear.
5	00000		Press the <b>DATA/SHIFT</b> Key for approximately one second. The current amount of offset will be displayed.
6	00002 Example:		Press the <b>UP</b> Key or <b>DOWN</b> Key to adjust the offset until the motor stops. The displayed value is the amount of the offset.
7	r.SPd		Press the <b>MODE/SET</b> Key. <b>donE</b> will flash on the display, and then the display shown on the left will appear.
8	Fn00A		Press the <b>DATA/SHIFT</b> Key for approximately one second to return the display to <b>Fn00A</b> .

Continued on next page

## 6.4.6 Manually Adjust Torque Reference Offset (Fn00B)

Refer to the following section for information on this utility function other than the procedure.

Step	Panel Display after Operation	Keys	Operation
1			Press the <b>MODE/SET</b> Key to enter Utility Function Mode.
2			Press the <b>UP</b> Key or <b>DOWN</b> Key to display <b>Fn00b</b> .
3			Press the <b>DATA/SHIFT</b> Key for approximately one second. The display shown on the left will appear. Note: If write protection is set, <b>no_oP</b> will flash on the display for approximately one second. Change the setting of Fn010 to enable writing.
4		-	Turn ON the servo. The display shown on the left will appear.
5			Press the <b>DATA/SHIFT</b> Key for approximately one second. The current amount of offset will be displayed.
6	 Example:		Press the <b>UP</b> Key or <b>DOWN</b> Key to adjust the amount of offset.
7			Press the <b>MODE/SET</b> Key. <b>donE</b> will flash on the display, and then the display shown on the left will appear.
8			Press the <b>DATA/SHIFT</b> Key for approximately one second to return the display to <b>Fn00b</b> .

## 6.4.7 Display Servomotor Model (Fn011)

Refer to the following section for information on this utility function other than the procedure.

Step	Panel Display after Operation	Keys	Operation
1			Press the <b>MODE/SET</b> Key to enter Utility Function Mode.
2			Press the <b>UP</b> Key or <b>DOWN</b> Key to display <b>Fn011</b> .

## 6.4.8 Display Software Version (Fn012)

Refer to the following section for information on this utility function other than the procedure.

Step	Panel Display after Operation	Keys	Operation
1			Press the <b>MODE/SET</b> Key to enter Utility Function Mode.
2			Press the <b>UP</b> Key or <b>DOWN</b> Key to display <b>Fn012</b> .
3			Press the <b>DATA/SHIFT</b> Key for approximately one second. The software version of the SERVOPACK will be displayed.
4			Press the <b>DATA/SHIFT</b> Key for approximately one second to return the display to <b>Fn012</b> .

## 6.4.9 Multiturn Limit Setting(Fn013) after Encoder copy alarm (A.810)

Refer to the following section for information on this utility function other than the procedure.

Step	Panel Display after Operation	Keys	Operation
1			Press the <b>MODE/SET</b> Key to enter Utility Function Mode.
2			Press the <b>UP</b> Key or <b>DOWN</b> Key to display <b>Fn013</b> .
3			Press the <b>DATA/SHIFT</b> Key for approximately one second. <b>PGSEt</b> will be displayed.
4			Press the <b>MODE/SET</b> Key. Flash around 1 second
5		—	After displaying <b>donE</b> , the display will return to the <b>PGSEt</b> display.
6			Press the <b>DATA/SHIFT</b> Key for approximately one second to return the display to <b>Fn013</b> .
7	To enable the change to the settings, turn the power supply to the SERVOPACK OFF and ON again.		

# Parameter Lists

---



This chapter provides information on the parameters.

## **7** List of Parameters ..... 7-2

7.1.1 Interpreting the Parameter Lists ..... 7-2

7.1.2 List of Parameters ..... 7-3

# 7.1 List of Parameters

## 7.1.1 Interpreting the Parameter Lists

The types of motors to which the parameter applies.

- All: The parameter is used for both Incremental and Absolute Servomotors.
- Incremental: only used in incremental servo motors.
- Absolute: The parameter is only used in Absolute servo motors.

Indicates when a change to the parameter will be effective.

Parameter No.	Size	Name	Setting Range	Setting Unit	Default Setting	Applicable Motors	When Enabled	Classification	Reference		
Pn000	2	Basic Function Selections 0	0000 to 00B1	-	0000	All	After restart	Setup	-		
	<p>There are the following two classifications.</p> <ul style="list-style-type: none"> <li>• Setup</li> <li>• Tuning</li> </ul>										
	n.□□□X		<b>Rotation Direction Selection</b>								
			<b>Movement Direction Selection</b>								
			0	Use CCW as the forward direction.							
			1	Use CW as the forward direction. (Reverse Rotation Mode)							
	n.□□X□		<b>Control Method Selection</b>								
			0	Speed control with analog references							
			1	Position control with pulse train references							
			2	Torque control with analog references							
			3	Internal set speed control with contact commands							
			4	Switching between internal set speed control with contact references and speed control with analog references							
			5	Switching between internal set speed control with contact references and position control with pulse train references							
			6	Switching between internal set speed control with contact references and torque control with analog references							
			7	Switching between position control with pulse train references and speed control with analog references							
		8	Switching between position control with pulse train references and torque control with analog references								
		9	Switching between torque control with analog references and speed control with analog references								
		A	Switching between speed control with analog references and speed control with zero clamping								
		B	Switching between position control with pulse train references and position control with reference pulse inhibition								
n.□X□□		Reserved parameter (Do not change.)									
n.X□□□		Reserved parameter (Do not change.)									

## 7.1.2

## List of Parameters

Parameter No.	Size	Name	Setting Range	Setting Unit	Default Setting	Applicable Motors	When Enabled	Classification
	2	Basic Function Selection 0	0000 to 10B1	–	0000	All	After restart	Setup
Pn000	n.□□□X	Rotation Direction Selection						
		Movement Direction Selection						
		0	Use CCW as the forward direction.					
		1	Use CW as the forward direction. (Reverse Rotation Mode)					
	n.□□X□	Control Method Selection						
		0	Speed control with analog references					
		1	Position control with pulse train references					
		2	Torque control with analog references					
		3	Internal set speed control with contact commands					
		4	Switching between internal set speed control with contact references and speed control with analog references					
		5	Switching between internal set speed control with contact references and position control with pulse train references					
		6	Switching between internal set speed control with contact references and torque control with analog references					
		7	Switching between position control with pulse train references and speed control with analog references					
		8	Switching between position control with pulse train references and torque control with analog references					
		9	Switching between torque control with analog references and speed control with analog references					
A		Switching between speed control with analog references and speed control with zero clamping						
B	Switching between position control with pulse train references and position control with reference pulse inhibition							
n.□X□□	Reserved parameter (Do not change.)							
n.X□□□	Reserved parameter (Do not change.)							

7.1 List of Parameters

7.1.2 List of Parameters

Continued from previous page.

Parameter No.	Bit No.	Name	Setting Range	Setting Unit	Default Setting	Applicable Motors	When Enabled	Classification	
Pn001	2	Application Function Selections 1	0000 to 1142	-	0000	All	After restart	Setup	
	n.□□□X	Motor Stopping Method for Servo OFF							
		0	Motor Is In Inertia running						
	n.□□X□	1	Reverse brake reduce the motor speed to stop ,and then In Locked state						
		Overtravel Stopping Method							
		0	Reverse brake reduce the motor speed to stop ,and then In free state						
	n.□□X□	1	Reverse brake reduce the motor speed to stop ,and then In Locked state						
		2	Motor Is In Inertia running						
	n.□X□□	Reserved parameter (Do not change.)							
	n.X□□□	Reserved parameter (Do not change.)							
Pn002	n.□□□X	Speed/Position Control Option (T-REF Input Allocation)					Applicable Motors		
		0	Do not use T-REF.					All	
		1	Use T-REF as an external torque limit input.						
		2	Use T-REF as a torque feedback input.						
	3	Use T-REF as an external torque limit input when /P-CL or /N-CL is ON.							
	n.□□X□	Torque Control Option (V-REF Input Allocation)					Applicable Motors		
		0	Do not use V-REF.					all	
	n.□X□□	Encoder Usage					Applicable Motors		
		0	Use the encoder as absolute one,Absolute data Serial output,(PG frequency division PA0)					absolute	
		1	Use the encoder as an incremental encoder.						
2	Use the encoder as a absolute encoder,Do not make the data Serial output.								
n.X□□□	Reserved parameter (Do not change.)					Applicable Motors			
Pn0A0		MODLE ITEM				INCREMENTAL	RE-POWER ON	SET	
Pn100	2	Speed Loop Gain	10 to 20,000	0.1 Hz	400	All	Immediately	Tuning	
Pn101	2	Speed Loop Integral Time Constant	15 to 51,200	0.01 ms	2000	All	Immediately	Tuning	
Pn102	2	Position Loop Gain	10 to 20,000	0.1/s	400	All	Immediately	Tuning	
Pn103	2	Moment of Inertia Ratio	0 to 20,000	1%	100	All	Immediately	Tuning	
Pn104	2	Second Speed Loop Gain	10 to 20,000	0.1 Hz	400	All	Immediately	Tuning	
Pn105	2	Second Speed Loop Integral Time Constant	15 to 51,200	0.01 ms	2000	All	Immediately	Tuning	

7.1 List of Parameters

7.1.2 List of Parameters

Continued from previous page.

Parameter No.	Size	Name	Setting Range	Setting Unit	Default Setting	Applicable Motors	When Enabled	Classification																
Pn106	2	Second Position Loop Gain	10 to 20,000	0.1/s	400	All	Immediately	Tuning																
Pn109	2	Feedforward	0 to 100	1%	0	All	Immediately	Tuning																
Pn10A	2	Feedforward Filter Time Constant	0 to 6,400	0.01 ms	0	All	Immediately	Tuning																
Pn10B	2	Gain Application Selections	0000 to 5334	-	0000	All	-	Setup																
			<table border="1"> <thead> <tr> <th colspan="2">Mode Switching Selection</th> <th>When Enabled</th> </tr> </thead> <tbody> <tr> <td>0</td> <td>Use the internal torque reference as the condition (level setting: Pn10C).</td> <td rowspan="6">Immediately</td> </tr> <tr> <td rowspan="2">1</td> <td>Use the speed reference as the condition (level setting: Pn10D).</td> </tr> <tr> <td>Use the speed reference as the condition (level setting: Pn181).</td> </tr> <tr> <td rowspan="2">2</td> <td>Use the acceleration reference as the condition (level setting: Pn10E).</td> </tr> <tr> <td>Use the acceleration reference as the condition (level setting: Pn182).</td> </tr> <tr> <td>3</td> <td>Use the position deviation as the condition (level setting: Pn10F).</td> </tr> <tr> <td>4</td> <td>Do not use mode switching.</td> </tr> </tbody> </table>					Mode Switching Selection		When Enabled	0	Use the internal torque reference as the condition (level setting: Pn10C).	Immediately	1	Use the speed reference as the condition (level setting: Pn10D).	Use the speed reference as the condition (level setting: Pn181).	2	Use the acceleration reference as the condition (level setting: Pn10E).	Use the acceleration reference as the condition (level setting: Pn182).	3	Use the position deviation as the condition (level setting: Pn10F).	4	Do not use mode switching.	
	Mode Switching Selection		When Enabled																					
	0	Use the internal torque reference as the condition (level setting: Pn10C).	Immediately																					
	1	Use the speed reference as the condition (level setting: Pn10D).																						
		Use the speed reference as the condition (level setting: Pn181).																						
	2	Use the acceleration reference as the condition (level setting: Pn10E).																						
		Use the acceleration reference as the condition (level setting: Pn182).																						
	3	Use the position deviation as the condition (level setting: Pn10F).																						
	4	Do not use mode switching.																						
n.□□□□		Reserved parameter (Do not change.)																						
n.□□□□		Reserved parameter (Do not change.)																						
n.X□□□		Reserved parameter (Do not change.)																						
Pn10C	2	Mode Switching Level for Torque Reference	0 to 300	1%	200	ALL	Immediately	Tuning																
Pn10D	2	Mode Switching Level for Speed Reference	0 to 10,000	1 min <sup>-1</sup>	0	ALL	Immediately	Tuning																
Pn10E	2	Mode Switching Level for Acceleration	0 to 30,000	1 min <sup>-1</sup> /s	0	ALL	Immediately	Tuning																
Pn10F	2	Mode Switching Level for Position Deviation	0 to 10,000	1 reference unit	0	All	Immediately	Tuning																
Pn121	2	Friction Compensation Gain	10 to 3,000		0	ALL	Immediately	Tuning																
Pn122	2	OVERLOAD OF FRICTION Compensation	10 to 3,000	1%	100	ALL	Immediately	Tuning																
Pn124	2	Viscous OverLoad of Friction Compensation	0 to 20,000	1%/1krpm	0	ALL	Immediately	Tuning																

7.1 List of Parameters

7.1.2 List of Parameters

Continued from previous page.

Parameter No.	Size	Name	Setting Range	Setting Unit	Default Setting	Applicable Motors	When Enabled	Classification	
Pn200	2	Position Control Reference Form Selections	0000 to 1423	-	0000	All	After restart	Setup	
	n.□□□X	<b>SIGNAL NEGATIVE DIRECTION</b>							
		0	PULS and SIGN command are both IN POSITIVE DIRECTION						
		1	PULS command IN POSITIVE DIRECTION WHILE SIGN NEGATIVE						
		2	PULS command IN NEGATIVE DIRECTION WHILE SIGN POSITIVE						
	3	PULS and SIGN command are both IN NEGATIVE DIRECTION							
	n.□□X□	<b>Clear Signal Form</b>							
		0	Clear position deviation when servo OFF,not Clear once pulse in over travel						
		1	NOT Clear position deviation when servo OFF or over travel						
	2	Clear position deviation when servo OFF or over travel							
	n.□X□□	<b>Pulse command state</b>							
		0	Signal +pulse						
		1	CW+CCW PULSE						
		2	90°phase difference= 1time phase pulse (A phase+B phase)						
		3	90°phase difference= 2 times phase pulse (A phase+B phase)						
4	90°phase difference= 4 times phase pulse (A phase+B phase)								
n.X□□□	<b>Filter Selection</b>								
	0	Use the reference input filter for a line-driver signal. (1 Mpps max.)							
1	Use the reference input filter for an open-collector signal. (200 kpps max.)								
Pn205	2	Multiturn Limit	0 to 65535	1 rev	65535	Absolute	After restart	Setup	
Pn20E	4	Electronic Gear Ratio (Numerator)	1 to 1,073,741,824	1	64	All	After restart	Setup	
Pn210	4	Electronic Gear Ratio (Denominator)	1 to 1,073,741,824	1	1	All	After restart	Setup	
Pn212	4	Number of Encoder Output Pulses	16 to 32768	1 P/Rev	2048	Rotary	After restart	Setup	
Pn216	2	Position Reference Acceleration/Deceleration Time Constant	0 to 65,535	0.1 ms	0	All	Immediately after the motor stops	Setup	
Pn300	2	Speed Reference Input Gain	0 to 3,000	(R/MIN)/V	150	ALL	Immediately	Setup	
Pn301	2	Internal Set Speed 1	0 to 10,000	1 min <sup>-1</sup>	100	ALL	Immediately	Setup	
Pn302	2	Internal Set Speed 2	0 to 10,000	1 min <sup>-1</sup>	200	ALL	Immediately	Setup	
Pn303	2	Internal Set Speed 3	0 to 10,000	1 min <sup>-1</sup>	300	ALL	Immediately	Setup	
Pn304	2	Jogging Speed	0 to 10,000	1 min <sup>-1</sup>	500		Immediately	Setup	
Pn305	2	Soft Start Acceleration Time	0 to 10,000	1 ms	0	All	Immediately	Setup	
Pn306	2	Soft Start Deceleration Time	0 to 10,000	1 ms	0	All	Immediately	Setup	
Pn307	2	Speed Reference Filter Time Constant	0 to 65,535	0.01 ms	40	All	Immediately	Setup	
Pn308	2	Speed Feedback Filter Time Constant	0 to 65,535	0.01 ms	0	All	Immediately	Setup	

Continued on next page.

Continued from previous page.

Parameter No.	Size	Name	Setting Range	Setting Unit	Default Setting	Applicable Motors	When Enabled	Classification
Pn400	2	Torque Reference Input Gain	10 to 100	0.1 V/ rated torque	30	All	Immediately	Setup
Pn401	2	First Stage First Torque Reference Filter Time Constant	0 to 65,535	0.01 ms	100	All	Immediately	Tuning
Pn402	2	Forward Torque Lfimit	0 to 300	1%	800	ALL	Immediately	Setup
Pn403	2	Reverse Torque Lfimit	0 to 300	1%	800	ALL	Immediately	Setup
Pn404	2	Forward External Torque Limit	0 to 300	1%	100	All	Immediately	Setup
Pn405	2	Reverse External Torque Limit	0 to 300	1%	100	All	Immediately	Setup
Pn406	2	Emergency Stop Torque	0 to 300	1%	800	All	Immediately	Setup
Pn407	2	Speed Limit during Torque Control	0 to 10,000	1 min <sup>-1</sup>	10000	ALL	Immediately	Setup
Pn409	2	First Stage Notch Filter Frequency	50 to 5,000	1 Hz	5000	All	Immediately	Tuning
Pn40A	2	First Stage Notch Filter Q Value	0 to 1,00	0.01	70	Affl	Immediately	Tuning
Pn40C	2	Second Stage Notch Filter Frequency	50 to 5,000	1 Hz	5000	All	Immediately	Tuning
Pn40D	2	Second Stage Notch Filter Q Value	50 to 1,000	0.01	70	All	Immediately	Tuning
Pn412	2	First Stage Second Torque Reference Filter Time Constant	0 to 65,535	0.01 ms	100	All	Immediately	Tuning
Pn501	2	Zero Clamping Level	0 to 10,000	1 min <sup>-1</sup>	10	ALL	Immediately	Setup
Pn502	2	Rotation Detection Level	1 to 10,000	1 min <sup>-1</sup>	20	ALL	Immediately	Setup
Pn503	2	Speed Coincidence Detection Signal Output Width	0 to 100	1 min <sup>-1</sup>	10	ALL	Immediately	Setup
Pn506	2	Brake Reference-Servo OFF Delay Time	0 to 50	10 ms	0	All	Immediately	Setup
Pn507	2	Brake Reference Output Speed Level	0 to 10,000	1 min <sup>-1</sup>	100	ALL	Immediately	Setup
Pn508	2	Servo OFF-Brake Command Waiting Time	10 to 100	10 ms	50	All	Immediately	Setup
Pn509	2	Momentary Power Interruption Hold Time	20 to 50,000	1 ms	20	All	Immediately	Setup

Continued from previous page.

Parameter No.	Size	Name	Setting Range	Setting Unit	Default Setting	Applicable Motors	When Enabled	Classification
Pn50A	2	Input Signal Selections <sup>1</sup>	0000 to FFF2	–	2100	All	After restart	Setup
	n.□□□X	Input Signal Allocation Mode						
		0	Use the sequence input signal terminals with the default allocations					
		1	Change the sequence input signal allocations.					
	n.□□X□	/S-ON (Servo ON) Signal Allocation						
		0	Active when CN3-7 Input signal is ON (closed).					
		1	Active when CN3-8 Input signal is ON (closed).					
		2	Active when CN3-9 Input signal is ON (closed).					
		3	Active when CN3-39 Input signal is ON (closed).					
		4	Active when CN3-25 Input signal is ON (closed).					
		5	Active when CN3-26 Input signal is ON (closed).					
		6	Active when CN3-41 Input signal is ON (closed).					
		7	The signal is always active.					
		8	The signal is always inactive.					
		9	Active when CN3-7 Input signal is OFF (open).					
		A	Active when CN3-8 Input signal is OFF (open).					
		B	Active when CN3-9 Input signal is OFF (open).					
		C	Active when CN3-39 Input signal is OFF (open).					
		D	Active when CN3-25 Input signal is OFF (open).					
		E	Active when CN3-26 Input signal is OFF (open).					
		F	Active when CN3-41 Input signal is OFF (open).					
	n.□X□□	/P-CON (Proportional Control) Signal Allocation						
		0 to F	The allocations are the same as the /S-ON (Servo ON) signal allocations.					
	n.X□□□	P-OT (Forward Drive Prohibit) Signal Allocation						
		0	Enable forward driver when CN3-7 input signal is ON (closed).					
		1	Enable forward driver when CN3-8 input signal is ON (closed).					
	2	Enable forward driver when CN3-9 input signal is ON (closed).						
	3	Enable forward driver when CN3-39 input signal is ON (closed).						
	4	Enable forward driver when CN3-25 input signal is ON (closed).						
	5	Enable forward driver when CN3-26 input signal is ON (closed).						
	6	Enable forward driver when CN3-41 input signal is ON (closed).						
	7	Set the signal to always prohibit forward drive.						
	8	Set the signal to always enable forward drive.						
	9	Enable forward driver when CN3-7 input signal is OFF (open)						
	A	Enable forward driver when CN3-8 input signal is OFF (open)						
	B	Enable forward driver when CN3-9 input signal is OFF (open)						
	C	Enable forward driver when CN3-39 input signal is OFF (open)						
	D	Enable forward driver when CN3-25 input signal is OFF (open)						
	E	Enable forward driver when CN3-26 input signal is OFF (open)						
	F	Enable forward driver when CN3-41 input signal is OFF (open)						

Continued on next page.

7.1 List of Parameters

7.1.2 List of Parameters

Continued from previous page.

Parameter No.	Size	Name	Setting Range	Setting Unit	Default Setting	Applicable Motors	When Enabled	Classification	
Pn50B	2	Input Signal Selections	0000 to FFFF	–	6543	All	After restart	Setup	
	n.□□□X	<b>N-OT (Reverse Drive Prohibit) Signal Allocation</b>							
		0	Enable reverse drive when CN3-7 input signal is ON (closed).						
		1	Enable reverse drive when CN3-8 input signal is ON (closed).						
		2	Enable reverse drive when CN3-9 input signal is ON (closed).						
		3	Enable reverse drive when CN3-39 input signal is ON (closed).						
		4	Enable reverse drive when CN3-25 input signal is ON (closed).						
		5	Enable reverse drive when CN3-26 input signal is ON (closed).						
		6	Enable reverse drive when CN3-41 input signal is ON (closed).						
		7	Set the signal to always prohibit reverse drive.						
		8	Set the signal to always enable reverse drive.						
		9	Enable reverse drive when CN3-7 input signal is OFF(open)						
		A	Enable reverse drive when CN3-8 input signal is OFF(open)						
		B	Enable reverse drive when CN3-9 input signal is OFF(open)						
		C	Enable reverse drive when CN3-39 input signal is OFF(open)						
		D	Enable reverse drive when CN3-25 input signal is OFF(open)						
		E	Enable reverse drive when CN3-26 input signal is OFF(open)						
	F	Enable reverse drive when CN3-41 input signal is OFF(open)							
	n.□□X□	<b>/ALM-RST (Alarm Reset) Signal Allocation</b>							
		0	Active on signal edge when CN 3-7 input signal changes from OFF (open) to ON (closed).						
		1	Active on signal edge when CN 3-8 input signal changes from OFF (open) to ON (closed).						
		2	Active on signal edge when CN 3-9 input signal changes from OFF (open) to ON (closed).						
		3	Active on signal edge when CN3-39 input signal changes from OFF (open) to ON (closed).						
		4	Active on signal edge when CN 3-25 input signal changes from OFF (open) to ON (closed).						
		5	Active on signal edge when CN 3-26 input signal changes from OFF (open) to ON (closed).						
		6	Active on signal edge when CN3-41 input signal changes from OFF (open) to ON (closed).						
		7	Reserved setting (Do not use.)						
		8	The signal is always inactive.						
		9	Active on signal edge when CN3-7 input signal changes from ON (closed) to OFF (open).						
		A	Active on signal edge when CN3-8 input signal changes from ON (closed) to OFF (open).						
		B	Active on signal edge when CN3-9 input signal changes from ON (closed) to OFF (open).						
		C	Active on signal edge when CN3-39 input signal changes from ON (closed) to OFF (open).						
		D	Active on signal edge when CN3-25 input signal changes from ON (closed) to OFF (open).						
		E	Active on signal edge when CN3-26 input signal changes from ON (closed) to OFF (open).						
	F	Active on signal edge when CN3-41 input signal changes from ON (closed) to OFF (open).							
	n.□X□□	<b>/P-CL (Forward External Torque Limit Input) Signal Allocation</b>							
		0 to F	The allocations are the same as the /S-ON (Servo ON) signal allocations.						
	n.X□□□	<b>/N-CL (Reverse External Torque Limit Input) Signal Allocation</b>							
		0 to F	The allocations are the same as the /S-ON (Servo ON) signal allocations.						

Continued on next page.

Continued from previous page.

Parameter No.	Size	Name	Setting Range	Setting Unit	Default Setting	Applicable Motors	When Enabled	Classification		
Pn50E	2	Output Signal Selections 1	0000 to 6666	-	4321	ALL	After restart	Setup		
	n.□□□X	(/ALM)Servo alarm Output) Signal Allocation		0	Disabled (the above signal output is not used).					
		1	Output the signal from CN3- 5 or CN 20 output terminal							
		2	Output the signal from CN3- 6 or CN 21 output terminal							
		3	Output the signal from CN3- 22 or CN 37 output terminal							
		4	Output the signal from CN3-22 or CN 38 output terminal							
		5	Output the signal from CN3-34 or CN 33 output terminal							
		6	Output the signal from CN3-36 or CN 35 output terminal							
	n.□□X□	(/COIN)Position Completion output signal Allocation		0 to 6	(/ALM) Servo alarm output					
		/TGON (Rotation Detection Output) Signal Allocation		0 to 6	(/ALM) Servo alarm output					
	n.X□□□	/S-RDY (Servo Ready) Signal Allocation		0 to 6	(/ALM) Servo alarm output					
	Pn50F	2	Output Signal Selections 2	0000 to 6666	-	0065	ALL	After restart	Setup	
		n.□□□X	/CLT (Torque Limit Detection Output) Signal Allocation		0	Disabled (the above signal output is not used).				
			1	Output the signal from the CN3-5 or CN3-20 output terminal						
			2	Output the signal from the CN3-6 or CN3-21 output terminal						
3			Output the signal from the CN3-22 or CN3-37 output terminal							
4			Output the signal from the CN3-23 or CN3-38 output terminal							
5			Output the signal from the CN3-34 or CN3-33 output terminal							
6			Output the signal from the CN3-36 or CN3-35 output terminal							
n.□□X□		(/BK) Brake control output		0 to 6	The allocations are the same as the /CLT (Torque Limit Detection Output) signal allocations.					
		(/PGC) Encoder original point output		0 to 6	The allocations are the same as the /CLT (Torque Limit Detection Output) signal allocations.					
n.X□□□		Reserved parameter (Do not change.)								

Continued on next page.

7.1 List of Parameters

7.1.2 List of Parameters

Continued from previous page.

Parameter No.	Size	Name	Setting Range	Setting Unit	Default Setting	Applicable Motors	When Enabled	Classification		
Pn512	2	Output Signal Selections 1	0000 to 6666	-	4321	ALL	After restart	Setup		
			<b>Output Signal Inversion for CN3-5 and CN3-20 Terminals</b>							
	n.□□□X		0	The signal is not inverted.						
			1	The signal is inverted.						
			<b>Output Signal Inversion for CN3-6 and CN3-21 Terminals</b>							
	n.□□X□		0	The signal is not inverted.						
			1	The signal is inverted.						
			<b>Output Signal Inversion for CN3-22 and CN3-37 Terminals</b>							
	n.□X□□		0	The signal is not inverted.						
			1	The signal is inverted.						
			<b>Output Signal Inversion for CN3-37 and CN3-38 Terminal</b>							
	n.X□□□		0	The signal is not inverted.						
			1	The signal is inverted.						
	Pn513	2	Output Signal Inverse Settings 2	0000 to 0011	-	0000	All	After restart	Setup	
				<b>Output Signal Inversion for CN3-34 and CN3-33 Terminal</b>						
		n.□□□X		0	The signal is not inverted.					
		1	The signal is inverted.							
		<b>Output Signal Inversion for CN3-36 and CN3-35 Terminal</b>								
n.□□X□		0	The signal is not inverted.							
		1	The signal is inverted.							
n.□X□□		Reserved parameter (Do not change.)								
n.X□□□		Reserved parameter (Do not change.)								
Pn522	4	Positioning Completed Width	0 to 65535	1 reference unit	10	ALL	Immediately	Setup		
	4	Position Deviation Overflow Alarm Level at Servo ON	1 to 32767	256 reference unit	1024	ALL	Immediately	Setup		

---

# Communication

- 8.1 Communication Wiring ..... 8-2
- 8.2 User Parameter ..... 8-2
- 8.3 MODBUS Communication Protocol ..... 8-3
- 8.4 MODBUS Communication Address ..... 8-10

Communication

SG-AS servo drives are equipped with standard MODBUS communication of RS485 interface and optional CANopen of CAN interface (conforming to DS301 and DS402 standard protocols). The Chapter mainly describes MODBUS communication.

8.1 Communication Wiring

Signal name and functions of communication connector are as follows::

Terminal No.	1	2	3	4	5	6	7	8
Name	CN1	CANH	CANL	GND	RS485-	RS485+	GND-	Built-in 120 ohm resistance
	CN2	CANH	CANL	GND	RS485-	RS485+	GND-	Reserved Reserved

Servo driver CN2 always acts as communication cable input terminal and, CN1 always as communication cable output terminal. Wiring diagram of several servo drives are as follows:

8.2 User Parameter

Pn010	RS-485 Communication Parameter Selection	<input type="checkbox"/> <input type="checkbox"/> <input type="checkbox"/> n. X	Communication baud rate Selection			Effective after power on again
			0	4800 bps		
			1	9600 bps		
			2	19200 bps		
			3	38400 bps		
		4	57600 bps			
		<input type="checkbox"/> <input type="checkbox"/> <input type="checkbox"/> n. X	Communication protocol selection			
			0	7, N, 2	Modbus ASCII mode	
			1	7, E, 1		
			2	7, O, 1		
3	8, N, 2		Modbus RTU mode			
4	8, E, 1					
5	8, O, 1					
6	8, N, 2					
7	8, E, 1					
8	8, O, 1					

Pn011	RS-485 Communication axis address	Set range 1 ~ 127	Effective after power on again
-------	-----------------------------------	-------------------	--------------------------------

Pn012	RS-485 Communication overtime parameter	Set range 0 ~ 1000	Unit 100ms	Effective after power on again
-------	---	--------------------	------------	--------------------------------

### 8.3 MODBUS Communication Protocol

In case of RS-485 communication, every servo drive must have parameters Pn010 ~ Pn012, preset.

In case of MODBUS protocol for communication, the following two modes are available:

ASCII mode

RTU mode

The following is the description of MODBUS communication

#### ■ Code meaning

ASCII mode:

Every 8-bit datum consists of two ASCII characters. For example, one 1-byte datum 64H (sexadecimal notation). ASCII code "64" indicates it includes ASCII code (36 H) of '6' and ASCII code (34 H) of '4'. ASCII codes of digits 0-9 and alphabets A-F are as shown in the table below:

Character symbol	'0'	'1'	'2'	'3'	'4'	'5'	'6'	'7'
Corresponding ASCII code	30H	31H	32H	33H	34H	35H	36H	37H
Character symbol	'8'	'9'	'A'	'B'	'C'	'D'	'E'	'F'
Corresponding ASCII code	38H	39H	40H	41H	42H	43H	44H	45H

RTU mode:

Every 8-bit datum consists of two 4-bit hexadecimal data. For instance, decimal 100 presents to be 64 H when using 1-byte RTU data.

#### ■ Character structure

10bitcharacter format (for 7-bit data)

7, N, 2 (Modbus, ASCII)

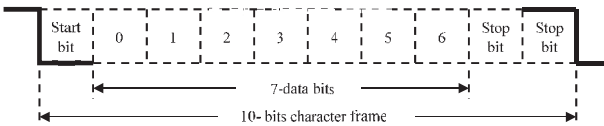

7, E, 1 (Modbus, ASCII)

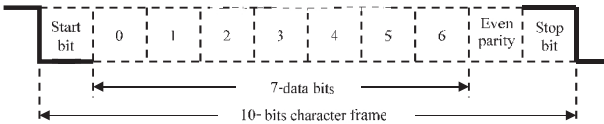

7, O, 1 (Modbus, ASCII)

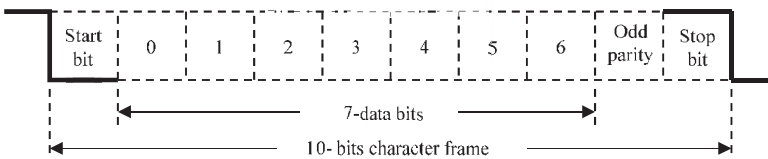

11bit character format (for 8-bit data)

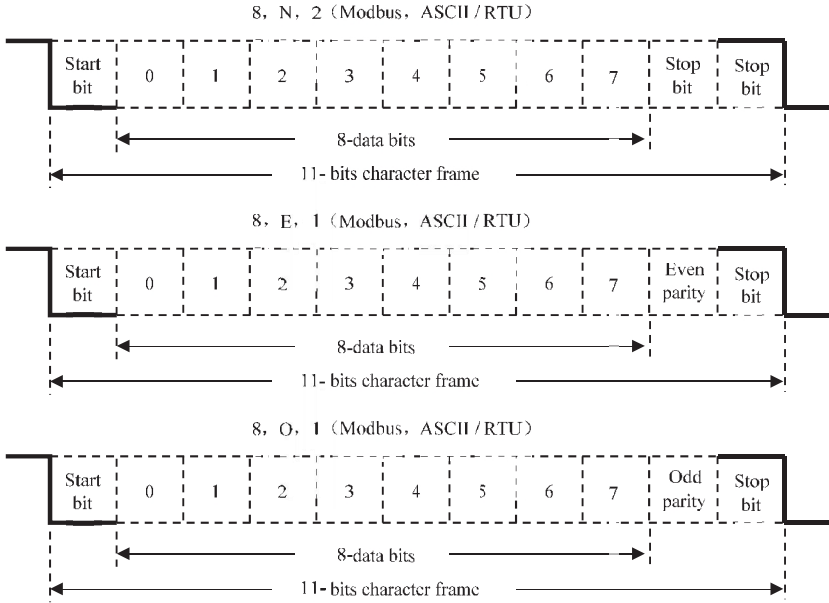

■ Communication data structure

ASCII mode:

STX	Beginning character ':' => (3A <sub>16</sub> )
ADR	Communication address => 1-byte includes 2 ASCII code
CMD	Communication code => 1-byte includes 2 ASCII code
DATA (n-1) 厖	Data content => n-word=2n-byte includes 4n ASCII code, n ≤ 12
DATA (0)	
LRC	Check code => 1-byte 包含了 2 个 ASCII code
End 1	End code1 => (0D <sub>16</sub> ) (CR)
End 0	End code 0 => (0A <sub>16</sub> ) (LF)

RTU mode:

STX	Rest time of at least four-byte transmission time
ADR	Communication address => 1-byte
CMD	Command code => 1-byte

DATA (n-1)	Data content => n-word=2n-byte, n ≤ 12
...	
DATA (0)	
CRC	CRC check code => 1-byte
End 1	Rest time of at least four-byte

Data format of communication protocol is described as follows:

STX (Communication starting)

ASCII mode: ':' character.

RTU mode: rest time of communication time (automatically changed based on different communication speed) for more than 4 bytes.

ADR (Communication address)

Legal communication address ranges from 1 to 254.

For example, communication for servo with address of 32 (sexadecimal 20):

ASCII mode: ADR= '2', '0' => '2' =32H

'0' =30H

RTU mode: ADR=20 H

CMD (Command) and DATA (Data)

Data format is determined based on command code. Common command codes are as follows:

Command code: 03 H, read N word (maximum of N is 20).

For example: Read 2 words from the starting address 0200 H in the servo with address of 01 H.

ASCII mode:

Command information:

STX	'.'
ADR	'0'
	'1'
CMD	'0'
	'3'
Starting data position	'0'
	'2'
	'0'
	'0'
Number of data	'0'
	'0'
	'2'
	'F'
LCR Check	'8'
	'E'
End 1	(0DH)(CR)
End 0	(0AH)(LF)

Respond information:

STX	'.'
ADR	'0'
	'1'
CMD	'0'
	'3'
Number of data (calculated by byte)	'0'
	'4'
Content of starting data address (0200H)	'0'
	'B'
	'1'
	'1'
Content of second data address (0201H)	'F'
	'4'
	'0'
	'0'
LCR Check	'E'
	'8'
End 1	(0DH)(CR)
End 0	(0AH)(LF)

RTU mode:

Command information:

ADR	01H
CMD	03H
Starting data position	02H(high byte)
	00H(low byte)
Number of data (calculated by word)	00H
CRC Check Low	C5H(low byte)
CRC Check High	B3H(high byte)

Respond information:

ADR	01H
CMD	03H
Number of data (calculated by byte)	04H
Content of starting data address (0200H)	00H(high byte)
	B1H(low byte)
Content of second data address (0201H)	1FH(high byte)
	40H(low byte)
CRC Check Low	A3H(low byte)
CRC Check High	D4H(high byte)

Command code: 06 H, write in 1 word

For example: write 100(0064 H) in address 0200 H of servo with office number 01 H.

ASCII mode:

Command information:

STX	'.'
ADR	'0'
	'1'
CMD	'0'
	'6'
Starting data position	'0'
	'2'
	'0'
	'0'
Content of data	'0'
	'0'
	'6'
	'4'
LCR Check	'9'
	'3'
End 1	(0DH)(CR)
End 0	(0AH)(LF)

Respond information:

STX	'.'
ADR	'0'
	'1'
CMD	'0'
	'6'
Starting data position	'0'
	'2'
	'0'
	'0'
Content of data	'0'
	'0'
	'6'
	'4'
LCR Check	'9'
	'3'
End 1	(0DH)(CR)
End 0	(0AH)(LF)

RTU mode :

Command information :

ADR	01H
CMD	06H
Starting data position	02H(high byte)
	00H(low byte)
Content of data	00H(high byte)
	64H(low byte)
CRC Check Low	89H(low byte)
CRC Check High	99H(high byte)

Respond information :

ADR	01H
CMD	06H
Starting data position	02H(high byte)
	00H(low byte)
Content of data	00H(high byte)
	64H(low byte)
CRC Check Low	89H(low byte)
CRC Check High	99H(high byte)

Calculation of detection error values of LRC (ASCII mode) and CRC (RTU mode):

LRC calculation of ASCII mode:

ASCII mode adopts LRC (Longitudinal Redunancy Check) detection error value. LRC detection error value is the sum of contents from ADR to the last data and the result is in the unit of 256 and removes exceeding part (for example, the result after totaling is sexadecimal 128 H and 28 H is then obtained), and then calculates its complement; thus the obtained results is the LRC detection error Value.

For example, read 1 word from 0201 address of servo with official number 01 H.

STX	'0'
ADR	'0'
	'1'
CMD	'0'
	'3'
Starting data position	'0'
	'2'
	'0'
	'1'
Number of data	'0'
	'0'
	'0'
	'1'
LCR Check	'F'
	'8'
End 1	(0DH)(CR)
End 0	(0AH)(LF)

Add from ADR data to the last data:

01 H +03 H +02 H +01 H +00 H +01 H =08 H, 08 H becomes F8 H after applying complement of 2, so

LRC is 'F' , '8' .

CRC calculation of RTU mode:

RTU mode adopts CRC (Cyclical Redundancy Check) detection error value.

**Steps for calculation of CRC detection error value are as follows:**

- Step 1: download a 16-bit register with content of FFFF H (called as "CRC" register).  
 Step 2: conduct XOR operation on the first bit (bit0) of command message and the low order bit(LSB) of 16-bit CRC register, and save the result to CRC register;  
 Step 3: check the lowest order (LSB) of CRC register; if it is 0, right shift CRC register value a bit; if it is 1, right shift CRC register value a bit and then conduct XOR operation with A001 H;  
 Step 4: return to Step 3, until 8 times of execution of Step 3, and then move to Step 5;  
 Step 5: repeat Step 2-4 for the next bit of the command message, until all bits are processed; the content of CRC register now is CRC detection error value.

**Note:** after CRC detection error value is calculated, it is necessary to fill the CRC low order in the command message and then CRC high order. Please refer to the following example.

For example: read 2 words from 0101 H address of servo with official number of 01 H. The final content of CRC register calculated from ADR to the last bit of the data number is 3794 H, and then its command message is as shown below. Note that 94 H is transmitted prior to 37 H.

ADR	01H
CMD	03 H
Starting data address	01H (address high order)
	01H (address low order)
Data number (Calculate based on word )	00H (high order)
	02H (low order)
CRC check low order	94H (check low order)
CRC check high order	37H (check high order)

**End1, End0 (communication detection completed)**

**ASCII mode:**

(0D H) (i.e. character '\r' [carriage return]) and (0A H) (i.e. '\n' [new line]) indicate end of communication.

**RTU mode:**

Exceeding the rest time of 4-byte communication time at the current communication rate indicates the end of communication.

**Example:**

The following uses C programming language to generate CRC value. The function needs two parameters:

```
unsigned char * data;
```

```
unsigned char length;
```

```
/*The function will pass back the CRC value in unsigned integer type.*/
```

```
unsigned int crc_chk(unsigned char * data,unsigned char length){
```

```
    int i,j;
```

```
    unsigned int crc_reg = 0xFFFF;
```

```
    while(length- -){
```

```

    crc_reg ^=*data++;
    for(j=0; j<8; j++){
        if(crc_reg & 0x01){
            crc_reg=( crc_reg >>1)^0xA001;
        }
        Else
        {
            crc_reg=crc_reg >>1;
        }
    }
}
return crc_reg;
}

```

#### ■ Communication error

During communication, errors are possible, and common error sources are as follows:

↳ During parameters reading and writing, data address is wrong;

↳ During writing of a parameter, the data exceed the maximum of the parameter or are smaller than the parameter;

↳ Communication is interrupted, data transmission is wrong or check code is wrong.

In case of the first two communication errors, operation of servo drive will not be affected and meanwhile the servo drive will feedback an error frame. In case of the third error, transmitted data will be considered to be invalid and abandoned, without feedback of frame.

Error frame format

is as follows:

##### Upper computer

###### data frame:

start	Slave station address	Command	Data address, data, etc.	Check
		Command		

##### Servo driver computer data frame:

start	Slave atation address	Respond code	Error code	Check
		Command+		

Where the error frame response code = command + 80 H;

Error code = 00 H; communication is normal;

= 01 H: servo drive fails to identify the requested function;

= 02 H: data address given in request does not exist in servo drive;

= 03 H: data address given in request is not allowed in servo drive (due to exceeding the maximum or minimum value of parameter);

= 04 H: servo drive has started to execute request, but fails to complete the request;

For example: the axis number of servo drive is 03H and datum 06H is written in parameter Pn100;

since the range of parameter Pn100 is 0-6, the written data will not be allowed and the servo drive will

return a error frame, with error code of 03H ( exceeding the maximum or minimum value of parameter)

and the structure as below:

**Upper computer data frame:**

start	Slave station address	Command	Data address,data,etc.	Check
	03H	06H	0002H 0006H	

**Servo driver feedbacks error frame:**

start	Slave station address	Response code	Error code	Check
	03H	86H	03H	

In addition, if the slave station address in data frame sent by upper computer is 00H, indicate that the data of the frame are broadcast data and the servo drive will not return any frame.

### 8.4 MODBUS Communication Address.

Communication data address	Meaning	Instruction	Operation
Hexadecimal system			
0000h~09FF	Parameter area	Correspond to parameters in parameter table	Read and write
3030h~3039h	Alarm information storage area	10 history alarms	Read only
3040h	Speed reference zero offset		Read only
3041h	Torque reference zero offset		Read only
3050h~3067h	Monitoring data		Read only
3050h	Motor speed	Unit:1r/min	Read only
3052h	Rotation angle (electric angle)	Unit:1deg	Read only
3054h	Input reference pulse speed	Unit:1kHz	Read only
3056h	Bus voltage	Unit:1V	Read only
3058h	Speed reference value of	Unit:1 r/min	Read only
305Ah	Analog input torque reference	Unit:1%	Read only
305Ch	Internal torque reference percent	Unit:1% or 0.1A	Read only
305Eh	Input signal monitoring	—	Read only
3060h	Output signal monitoring	—	Read only

Communication data address	Meaning	Instruction	Operation
Hexadecimal system			
3062h	Encoder signal monitoring	—	Read only
3064h	Input reference pulse counter	Unit: 1 reference pulse	Read only
3066h	Feedback pulse counter	Unit: 1 reference pulse	Read only
3068h	Position error counter	Unit: 1 reference pulse	Read only
306Ah	Accumulated load	Unit:1%	Read only
306Ch	Rotational inertia percent	Unit:1%	Read only
306Eh	Actual angle of encoder	Unit: 1 reference pulse	Read only
3070h	Encoder multi-circle position	Unit: 1 circle	Read only
307Ah	Current alarm		Read only
3081h	Communication IO signal	Power failure not saved	Read and write
3082h	Communication output port reverse	Power failure not saved	Read and write
3087h	Servo operation status		Read only
3120h	Clear history alarm	1: Clear history alarm	Read and write
3121h	Clear current alarm	1: Clear current alarm	Read and write
3122h	Clear bus encoder alarm	1: Clear bus encoder alarm	Read and write
3123h	Clear bus encoder multi-circle data	1: Clear bus encoder multi-circle data	Read and write
3128h	Speed JOG	BIT15:1 JOG servo enable BIT01:1 JOG- (JOG positive) BIT00:1 JOG+ (JOG negative)	Read and write
3129h	Position JOG	BIT15:1 Enter position jog mode BIT01:1 JOG- BIT00:1 JOG+	Read and write
3140h	Factory reset	1: Factory reset	Writable
3141h	Reset	1: Reset	Writable

SG-AS Series AC Servo Drive  
SG-AS SERVOPACK with  
Analog Voltage/Pulse Train References  
Product Manual

---

---