

Σ Series SGM□/SGDB USER'S MANUAL

AC Servodrives

SGMG/SGMS/SGMD/SGMP Servomotors
SGDB-□N SERVOPACK





YASKAWA

MANUAL NO. SIE-S800-26.4C

Safety Information

The following conventions are used to indicate precautions in this manual. Failure to heed precautions provided in this manual can result in serious or possibly even fatal injury or damage to the products or to related equipment and systems.

 **WARNING** Indicates precautions that, if not heeded, could possibly result in loss of life or serious injury.

 **CAUTION** Indicates precautions that, if not heeded, could result in relatively serious or minor injury, damage to the product, or faulty operation.

©Yaskawa, 1998

All rights reserved. No part of this publication may be reproduced, stored in a retrieval system, or transmitted, in any form, or by any means, mechanical, electronic, photocopying, recording, or otherwise, without the prior written permission of Yaskawa. No patent liability is assumed with respect to the use of the information contained herein. Moreover, because Yaskawa is constantly striving to improve its high-quality products, the information contained in this manual is subject to change without notice. Every precaution has been taken in the preparation of this manual. Nevertheless, Yaskawa assumes no responsibility for errors or omissions. Neither is any liability assumed for damages resulting from the use of the information contained in this publication.

OVERVIEW

Overview	v
Safety Precautions	xiv
<hr/>	
Safety Precautions	xiii
1 Configuration and Models	
1.1 Configuration	1 -2
1.2 Model Numbers	1 -2
2 Ratings and Characteristics	
2.1 Ratings and Specifications of SGMG Servomotors for Rated Speed 1500 r/min	2 -2
2.2 Ratings and Specifications of SGMG Servomotors for Rated Speed 1000 r/min	2 -6
2.3 SGMS Servomotor Ratings and Specifications	2 -10
2.4 SGMD Servomotor Ratings and Specifications (with Holding Brake)	2 -13
2.5 SGMP Servomotor (1.5 kW) Ratings and Specifications	2 -15
2.6 SERVOPACK Ratings and Specifications	2 -17
2.7 Combined Specifications	2 -19
3 Servodrive Characteristics	
3.1 Overload Characteristics	3 -2
3.2 Starting and Stopping Time	3 -3
3.3 Allowable Repeatability	3 -4
3.4 Large-amplitude Frequency Characteristics	3 -6
3.5 Mechanical Characteristics	3 -7
4 Configuration and Connections	
4.1 Internal Connection Diagram	4 -3
4.2 Name and Description of Main Circuit Terminals	4 -7
4.3 Applicable Receptacles	4 -7
4.4 Connecting an Incremental Encoder	4 -9
4.5 Connecting an Absolute Encoder	4 -14
4.6 Output Circuits	4 -18
4.7 Connector Terminal Block Converter Unit for 1CN	4 -19
4.8 2CN Encoder Connector Terminals	4 -22
4.9 4CN Connectors for MECHATROLINK Communications	4 -26
5 Application	
5.1 Turning Power ON/OFF	5 -3
5.2 Position Control	5 -4
5.3 Setting Up a 12-bit Absolute Encoder	5 -6
5.4 Protection Functions	5 -8
5.5 Indications	5 -9
5.6 Precautions	5 -10
5.7 Application Precautions	5 -13

5.8 Appropriate Applications	5 -18
5.9 Adjustments	5 -19

6 MECHATROLINK Communication

6.1 Specifications and Configuration	6 -2
6.2 1SW Rotary Switch for MECHATROLINK Station Address Settings	6 -3
6.3 MECHATROLINK Command List	6 -4
6.4 Special Descriptions	6 -7
6.5 Power ON Sequence (Communications Sequence)	6 -15
6.6 List of Alarm and Warning Codes	6 -18

7 User Constants

7.1 Setting User Constants	7 -2
7.2 List of User Constants	7 -13
7.3 Memory Switch Bit Details	7 -16
7.4 Limits to User Constant Changes	7 -22
7.5 Procedure for Transferring User Constants	7 -23

8 Installation and Wiring

8.1 Checking on Delivery	8 -2
8.2 Installation	8 -3
8.3 Wiring Specifications	8 -7

9 Servodrives Dimensional Drawings

9.1 AC Servomotors	9 -3
9.2 SERVOPACKS	9 -53
9.3 Cables	9 -64
9.4 Connectors	9 -75
9.5 Noise Filters	9 -94
9.6 Peripheral Devices	9 -96

10 Trial Operation

10.1 Check Items before Trial Operation	10 -2
10.2 Trial Operation Procedure	10 -3

11 Settings

11.1 Characteristics when Shipped	11 -2
11.2 Resetting	11 -2
11.3 Adjusting Servo Performance	11 -2

12 Maintenance and Inspection

12.1 Maintenance and Inspection of Servodrives	12 -2
12.2 Troubleshooting	12 -5

TABLE OF CONTENTS

Overview	v
Safety Precautions	xiv
1 Configuration and Models	
1.1 Configuration	1 -2
1.2 Model Numbers	1 -2
1.2.1 Servomotor Model Numbers	1 -2
1.2.2 SERVOPACK Model Numbers	1 -4
2 Ratings and Characteristics	
2.1 Ratings and Specifications of SGMG Servomotors for Rated Speed 1500 r/min	2 -2
2.1.1 Ratings and Specifications	2 -2
2.2 Ratings and Specifications of SGMG Servomotors for Rated Speed 1000 r/min	2 -6
2.2.1 Ratings and Specifications	2 -6
2.3 SGMS Servomotor Ratings and Specifications	2 -10
2.3.1 Ratings and Specifications	2 -10
2.4 SGMD Servomotor Ratings and Specifications (with Holding Brake)	2 -13
2.4.1 Ratings and Specifications	2 -13
2.5 SGMP Servomotor (1.5 kW) Ratings and Specifications	2 -15
2.5.1 Ratings and Specifications	2 -15
2.6 SERVOPACK Ratings and Specifications	2 -17
2.6.1 Ratings and Specifications	2 -17
2.7 Combined Specifications	2 -19
2.7.1 Standard Combinations	2 -19
2.7.2 Peripheral Device Combinations	2 -22
3 Servodrive Characteristics	
3.1 Overload Characteristics	3 -2
3.2 Starting and Stopping Time	3 -3
3.3 Allowable Repeatability	3 -4
3.3.1 Allowable Repeatability as Limited by the Servomotor	3 -4

3.4 Large-amplitude Frequency Characteristics	3 -6
3.5 Mechanical Characteristics	3 -7
3.5.1 Mechanical Strength	3 -7
3.5.2 Allowable Radial and Thrust Load	3 -7
3.5.3 Mechanical Tolerances	3 -8
3.5.4 Direction of Motor Rotation	3 -8
3.5.5 Impact Resistance	3 -8
3.5.6 Vibration Resistance	3 -9
3.5.7 Vibration Class	3 -9
4 Configuration and Connections	
4.1 Internal Connection Diagram	4 -3
4.1.1 0.5 kW to 1.5 kW Servodrives	4 -3
4.1.2 2.0 kW to 3.0 kW Servodrives	4 -4
4.1.3 5.0 kW Servodrive	4 -5
4.1.4 6.0 kW to 15.0 kW Servodrives	4 -6
4.2 Name and Description of Main Circuit Terminals	4 -7
4.3 Applicable Receptacles	4 -7
4.3.1 1CN Connector for I/O Signals	4 -7
4.3.2 2CN Connector for Encoder	4 -7
4.3.3 4CN Connector for MECHATROLINK Communication	4 -8
4.4 Connecting an Incremental Encoder	4 -9
4.4.1 Typical Example	4 -9
4.4.2 1CN I/O Connector Terminals	4 -10
4.5 Connecting an Absolute Encoder	4 -14
4.5.1 Typical Example	4 -14
4.5.2 1CN I/O Connector Terminals	4 -15
4.6 Output Circuits	4 -18
4.7 Connector Terminal Block Converter Unit for 1CN	4 -19
4.7.1 Application	4 -19
4.7.2 Connection Specifications	4 -20
4.7.3 Cable Specifications Accessory (for Connector Terminal Block Converter Unit)	4 -21
4.8 2CN Encoder Connector Terminals	4 -22
4.8.1 2CN Terminal Layout	4 -22
4.8.2 Applicable Cables	4 -23
4.8.3 2CN Connection Method	4 -24
4.9 4CN Connectors for MECHATROLINK Communications	4 -26
4.9.1 4CN Terminal Layout	4 -26
4.9.2 4CN Connection Method	4 -26

5	Application	
5.1	Turning Power ON/OFF	5 -3
5.2	Position Control	5 -4
5.2.1	Electronic Gear Function	5 -4
5.2.2	Feed-forward Control Function	5 -5
5.3	Setting Up a 12-bit Absolute Encoder	5 -6
5.3.1	Battery	5 -6
5.3.2	Absolute Encoder Setup Procedure	5 -6
5.4	Protection Functions	5 -8
5.4.1	Dynamic Brake Function	5 -8
5.4.2	Error Detection Function	5 -8
5.4.3	Servo Alarm Output (ALM, ALM-SG)	5 -9
5.4.4	Handling Protection Circuit Operation	5 -9
5.4.5	Servo Alarm Reset	5 -9
5.5	Indications	5 -9
5.6	Precautions	5 -10
5.6.1	Overhanging Load	5 -10
5.6.2	Load Inertia J_L	5 -10
5.6.3	Regenerative Resistor Unit	5 -10
5.6.4	High Voltage Lines	5 -12
5.7	Application Precautions	5 -13
5.7.1	Noise Control	5 -13
5.7.2	Power Supply Line Protection	5 -16
5.8	Appropriate Applications	5 -18
5.8.1	Holding Brake Interlock Signal	5 -18
5.9	Adjustments	5 -19
5.9.1	Servo System Adjustments	5 -19
5.9.2	User Constants	5 -20
5.9.3	Functions that Improve Response	5 -23
5.9.4	Guidelines for Setting the Load Inertia Ratio	5 -24
6	MECHATROLINK Communication	
6.1	Specifications and Configuration	6 -2
6.1.1	Specifications	6 -2
6.1.2	Control Structure	6 -2
6.2	1SW Rotary Switch for MECHATROLINK Station Address Settings	6 -3
6.3	MECHATROLINK Command List	6 -4

6.4 Special Descriptions	6-7
6.4.1 Option Field Specifications	6-7
6.4.2 I/O Monitor Specifications	6-8
6.4.3 Monitor 1/2 Type Field Specifications	6-9
6.4.4 CONFIG Specifications	6-10
6.4.5 ALM_RD Specifications	6-10
6.4.6 ALM_CLR Specifications	6-11
6.4.7 CONNECT Specifications	6-11
6.4.8 INTERPOLATE Specifications	6-12
6.4.9 LATCH (Interpolation Feed with Position Detection) Specifications	6-12
6.4.10 POSING Command Specifications	6-13
6.4.11 INTERPOLATE Command Specifications	6-13
6.4.12 ID_RD (ID Read) Specifications	6-13
6.4.13 Unsupported Commands	6-14
6.5 Power ON Sequence (Communications Sequence)	6-15
6.6 List of Alarm and Warning Codes	6-18
7 User Constants	
7.1 Setting User Constants	7-2
7.1.1 Basic User Constants	7-2
7.1.2 Gain-related Constants	7-2
7.1.3 Torque-related Constants	7-3
7.1.4 Sequence-related Constants	7-4
7.1.5 Motion-related Constants	7-5
7.1.6 Other Constants	7-8
7.1.7 Memory Switches	7-9
7.2 List of User Constants	7-13
7.3 Memory Switch Bit Details	7-16
7.3.1 Cn-0001: Memory Switches 1	7-16
7.3.2 Cn-0002: Memory Switches 2	7-18
7.3.3 Cn-0013: Memory Switches 3	7-19
7.3.4 Cn-0014: Memory Switches 4	7-20
7.4 Limits to User Constant Changes	7-22
7.5 Procedure for Transferring User Constants	7-23
8 Installation and Wiring	
8.1 Checking on Delivery	8-2
8.2 Installation	8-3
8.2.1 Installing the Servomotor	8-3
8.2.2 Installing the SERVOPACK	8-4

8.3 Wiring Specifications	8 -7
8.3.1 Rated Current and Cable Specifications	8 -7
8.3.2 Wiring Instructions	8 -9
8.3.3 Power Loss	8 -11
9 Servodrives Dimensional Drawings	
9.1 AC Servomotors	9 -3
9.1.1 SGMG-□□A□A Servomotors	9 -3
9.1.2 SGMG-□□A□B Servomotors	9 -16
9.1.3 SGMS-□□A Servomotors	9 -26
9.1.4 SGMD-□□A Servomotors	9 -34
9.1.5 SGMP-15A Servomotor	9 -38
9.1.6 List of Encoder and Servomotor End Connectors	9 -46
9.2 SERVOPACKS	9 -53
9.2.1 SGDB-05AN□ to 15AN□ SERVOPACKS (0.5 to 1.5 kW)	9 -53
9.2.2 SGDB-20AN□ to 30AN□ SERVOPACKS (2.0 to 3.0 kW)	9 -54
9.2.3 SGDB-50AN□ SERVOPACKS (5.0 kW)	9 -55
9.2.4 SGDB-60AN□ to 75AN□ SERVOPACKS (6.0 to 7.5 kW)	9 -56
9.2.5 SGDB-1AAN, 1EAN SERVOPACKS (11, 15 kW)	9 -57
9.2.6 SGDB-05AN□-P to 15AN□-P SERVOPACKS	9 -58
9.2.7 SGDB-20AN□-P to 30AN□-P SERVOPACKS	9 -59
9.2.8 SGDB-50AN□-P SERVOPACK	9 -60
9.2.9 SGDB-60AN□ to 75AN□-P SERVOPACKS	9 -61
9.2.10 SGDB-1AAN-P, 1EAN-P SERVOPACKS	9 -62
9.3 Cables	9 -64
9.3.1 Encoder Cables	9 -64
9.3.2 Servomotor Cables	9 -73
9.3.3 I/O Signal Cables (1CN)	9 -74
9.3.4 MECHATROLINK Communication Cables (4CN)	9 -74
9.4 Connectors	9 -75
9.4.1 SGMG, SGMS and SGMD Servomotors Connections	9 -75
9.4.2 SGM and SGMP Servomotors Connections	9 -87
9.4.3 SGMP-15A Servomotor Connectors	9 -89
9.4.4 SERVOPACK Encoder Connectors	9 -90
9.4.5 1CN, 2CN Connector for SERVOPACK	9 -92
9.4.6 4CN Connector for SERVOPACK	9 -93
9.5 Noise Filters	9 -94
9.5.1 Dimensional Diagram	9 -94
9.6 Peripheral Devices	9 -96
9.6.1 Connector Terminal Block Converter Unit	9 -96
9.6.2 Brake Power Supply	9 -96
9.6.3 Molded-case Circuit Breaker	9 -98
9.6.4 Magnetic Contactor	9 -98
9.6.5 Surge Suppressor	9 -100
9.6.6 Regenerative Resistor Unit	9 -100
9.6.7 Analog Monitor Cable	9 -101

10	Trial Operation	
10.1	Check Items before Trial Operation	10 -2
10.1.1	Servomotors	10 -2
10.1.2	SERVOPACKS	10 -2
10.2	Trial Operation Procedure	10 -3
10.2.1	Preparations for Trial Operation	10 -3
10.2.2	Operating the Servodrive	10 -4
10.2.3	Trial Operation Inspection	10 -4
11	Settings	
11.1	Characteristics when Shipped	11 -2
11.2	Resetting	11 -2
11.3	Adjusting Servo Performance	11 -2
11.3.1	Setting User Constants	11 -2
11.3.2	Setting Optimum Position and Speed Loop Gain	11 -3
12	Maintenance and Inspection	
12.1	Maintenance and Inspection of Servodrives	12 -2
12.1.1	Servomotor Inspection	12 -2
12.1.2	SERVOPACK Inspection	12 -3
12.1.3	Replacing the Battery for Absolute Encoders	12 -4
12.2	Troubleshooting	12 -5
12.2.1	Servomotors	12 -5
12.2.2	SERVOPACKS	12 -6

Preface

Based on Yaskawa servo manufacturing technology and servo application technology accumulated over the last half a century, Yaskawa has launched the AC Servo Series that, together with its rich line of products, meets the needs of the modern needs of FA and FMS in their application to machining tools and robots.

AC Servos not only provide stable, highly accurate, and high-speed response control even under adverse environments, but also provide such features as easy application, flexibility, and easy maintain. The new Yaskawa AC Servos can be used in various servo fields, including machining tools and robots.

Features

- The base-mounted SERVOPACKS are provided as a single unit compatible with either incremental encoders or absolute encoders.
- Positioning via the MECHATROLINK High-speed Field Network.
- Electronic gear function provided.
- For incremental encoders, there are now only 9 lines to wire between the encoder and the SERVOPACK (previously 15 lines).
- Wiring is reduced by a reduction in the number of I/O from 15 to 6.
- Distributed system design is now possible with a maximum cable length of 50 m (previously 3 m).

Related Manuals

Refer to the following manuals as required

Read this manual carefully to ensure the proper use of the SERVOPACKS. Also, keep this manual in a safe place so that it can be referred to whenever necessary.

Manual Name	Manual No.	Contents
MECHATROLINK Systems User's Manual	SIE-S800-26.1	Gives a detailed description of the MECHATROLINK Network.
MECHATROLINK Servo Command User's Manual	SIE-S800-26.2	Provides a detailed description of the MECHATROLINK servo commands.

Safety Precautions

The following precautions are for checking products upon delivery, installation, wiring, operation, maintenance and inspections.

■ Checking Products on Delivery

CAUTION

- Be sure to use the specified Servomotor and SERVOPACK combination.
Fire or damage may result if the wrong combination is used..

■ Installation

CAUTION

- Do not use the products in or near environments exposed to moisture, corrosive gases, flammable gases , or other flammable materials.
Electric shock or fire may result.

■ Wiring

WARNING

- Be sure to ground the SERVOPACK ground terminal  less than 100 Ω.
Electric shock or fire may result if the SERVOPACK is not grounded properly.

CAUTION

- Do not connect a three-phase power supply to the U, V, and W output terminals of the SERVO-PACK.
Injury or fire may result.
- Make sure the power supply and Servomotor output terminals are securely tightened.
Fire may result if terminals are loose.

■ Operation **WARNING**

- Do not touch rotating parts of the Servomotor during operation.
Injury may result.

 **CAUTION**

- In order to avoid accidents, do not connect the Servomotor shaft to the controlled equipment during the trial operation.
Injury may result.
- Be sure to set the proper user constants for the controlled equipment prior to starting operation with the Servomotor connected to the equipment.
Equipment overrun or damage may result without proper settings prior to the start of operation.
- Always set up an emergency stop prior to starting operation with the Servomotor connected to the equipment.
Injury may result if an emergency stop is not readily available.
- Do not touch the heat sink area during operation.
Severe burns due to high temperatures may result.

■ Maintenance and Inspection **WARNING**

- Do not touch areas inside the SERVOPACK.
Electric shock may result.
- Make sure the panel cover is attached when power is ON.
Electric shock may result if the panel cover is left open.
- Turn OFF power and wait 5 minutes before touching terminals.
Electric shock from residual voltage may result if terminals are touched within 5 minutes of turning OFF power.

 **CAUTION**

- Do not disassemble the Servomotor.
Electric shock or injury may result.
- Do not change wiring with the power turned ON.
Electric shock or injury may result.

■ General Precautions

Note the following to ensure safe application.

- The drawings presented in this manual are sometimes shown without covers or protective guards. Always replace the cover or protective guard as specified first, and then operate the products in accordance with the manual.
- The drawings presented in this manual are typical examples and may not match the product you received.
- This manual is subject to change due to product improvement, specification modification, and manual improvement. When this manual is revised, the manual code is updated and the new manual is published as a next edition. The edition number appears on the front and back covers.
- If the manual must be ordered due to loss or damage, inform your nearest Yaskawa representative or one of the offices listed on the back of this manual.
- Yaskawa will not take responsibility for the results of unauthorized modifications of this product. Yaskawa shall not be liable for any damages or troubles resulting from unauthorized modification.

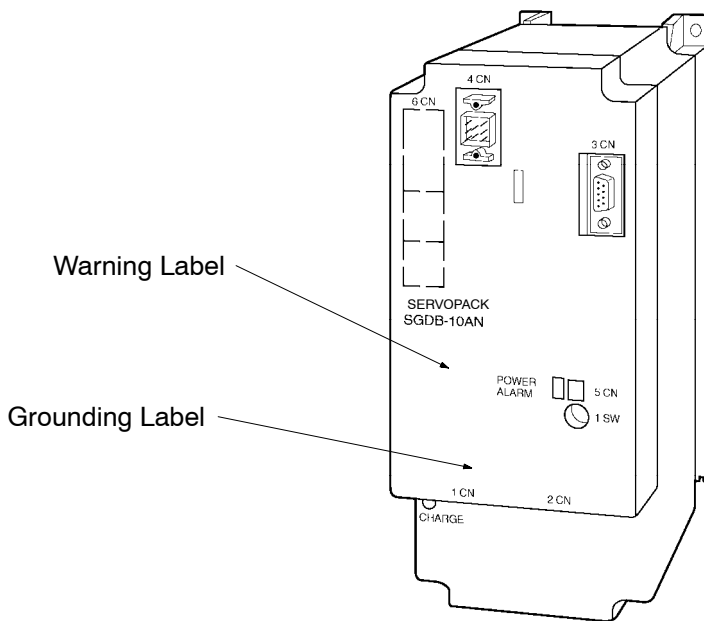

Warning Label



Grounding Label



Warning Label and Grounding Label Sticker Attachment Positions

1

Configuration and Models

This chapter describes the configuration and model numbers for Servo-drives.

1.1 Configuration	1 - 2
1.2 Model Numbers	1 - 2
1.2.1 Servomotor Model Numbers	1 - 2
1.2.2 SERVOPACK Model Numbers	1 - 4

1.1 Configuration

Servodrives are configured using a SERVOPACK (Controller) and Servomotors.

- SGDB-□□AN SERVOPACK

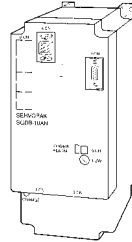

- AC Servomotor

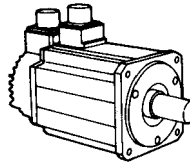

1.2 Model Numbers

1.2.1 Servomotor Model Numbers

■ SGMP Servomotors

SGMP - 15 A 3 1 2 □

Σ-Series
 SGMP: SGMP Servomotor

Servomotor Capacity
 04: 400 W, 08: 750 W, 15: 1.5 kW

Supply Voltage
 A: 200 V

Options

- B: With brake
- D: With brake and shaft seal
- P: Drip-proof
- S: With shaft seal

Shaft Specifications

- 2: Straight without key
- 4: Straight with key
- 6: Straight with key and tap

Design Revision Order

Encoder Specification

- 3: 2048 P/R incremental encoder
- W: 12-bit absolute encoder (special order)

■ SGMG/SGMS/SGMD Servomotors

SGM□ - 03 A 2 A A □ □

Σ-Series

SGMG: SGMG Servomotor
SGMS: SGMS Servomotor
SGMD: SGMD Servomotor

Servomotor Capacity

03: 0.3 kW, 05: 0.45 kW, 06: 0.6 kW
09: 0.85 kW/0.9 kW, 10: 1.0 kW
12: 1.2 kW, 13: 1.3 kW, 15: 1.5 kW
20: 1.8 kW/2.0 kW, 22: 2.2 kW
30: 2.9 kW/3.0 kW, 32: 3.2 kW
40: 4.0 kW, 44: 4.4 kW, 50: 5.0 kW
55: 5.5 kW, 60: 6.0 kW, 75: 7.5 kW
1A: 11 kW, 1E: 15 kW

Supply Voltage

A: 200 V

Encoder Specification

2: 8192 P/R incremental encoder
6: 4096 P/R incremental encoder
W: 12-bit absolute encoder
S: 15-bit absolute encoder

Lead Specification

Blank: Standard connector

Options

Blank: Standard
1: Standard
(with a lead specification)
S: With shaft seal
B: With 90 VDC brake
C: With 24 VDC brake
F: With shaft seal
and 90 VDC brake
G: With shaft seal
and 24 VDC brake

Shaft Specification

Blank: Standard
[Straight without key]
A: Standard [Straight without key]
(with an optional/lead specification)
B: Straight with key, with axis end tap (1)
C: Taper 1/10, with parallel key
D: Taper 1/10, with woodruff key
(G Series 05 and 09 only)

Rated Motor Speed

A: SGMG 1500 r/min
SGMS 3000 r/min
SGMD 2000 r/min
B: SGMG 1000 r/min

1.2.2 SERVOPACK Model Numbers

SGDB - 10 A N -

Σ-Series

SGDB SERVOPACK

Rated Output

05: 0.5 kW, 10: 1.0 kW, 15: 1.5 kW
20: 2.0 kW, 30: 3.0 kW, 50: 5.0 kW
60: 6.0 kW, 75: 7.5 kW, 1A: 11.0 kW
1E: 15.0 kW

Supply Voltage

A: 200 V

Options

P: Duct ventilation

Command Interface Type

N: MECHATROLINK

1

2

Ratings and Characteristics

This chapter provides Servodrive ratings, specifications, and torque-speed characteristics.

For SGM Servomotors (400 W, 750 W) and SGMP Servomotors (400 W, 750 W), refer to “Σ Series SGM/SGMP/SGD-□N USER’S MANUAL” (SIE-S800-26.3).

2.1 Ratings and Specifications of SGMG Servomotors	
for Rated Speed 1500 r/min	2 -2
2.1.1 Ratings and Specifications	2 -2
2.2 Ratings and Specifications of SGMG Servomotors	
for Rated Speed 1000 r/min	2 -6
2.2.1 Ratings and Specifications	2 -6
2.3 SGMS Servomotor Ratings and Specifications	2 -10
2.3.1 Ratings and Specifications	2 -10
2.4 SGMD Servomotor Ratings and Specifications	
(with Holding Brake)	2 -13
2.4.1 Ratings and Specifications	2 -13
2.5 SGMP Servomotor (1.5 kW) Ratings and	
Specifications	2 -15
2.5.1 Ratings and Specifications	2 -15
2.6 SERVOPACK Ratings and Specifications	2 -17
2.6.1 Ratings and Specifications	2 -17
2.7 Combined Specifications	2 -19
2.7.1 Standard Combinations	2 -19
2.7.2 Peripheral Device Combinations	2 -22

2.1 Ratings and Specifications of SGMG Servomotors for Rated Speed 1500 r/min

2.1.1 Ratings and Specifications

- Time Rating: Continuous
- Enclosure: Totally enclosed, self cooled, IP67 (except shaft-through section)
- Excitation: Permanent magnet
- Insulation Class: Class F
- Drive Method: Direct drive
- Vibration Class: 15 μm or below
- Ambient Temperature: 0 to 40°C
- Mounting: Flange method
- Withstand Voltage: 1500 VAC
- Ambient Humidity: 20% to 80% (with no condensation)
- Insulation Resistance: 500 VDC, 10 M Ω min.

Table 2.1 Ratings and Specifications of SGMG Servomotors for Rated Speed 1500 r/min

Servomotor Model: SGMG-		05A□A	09A□A	13A□A	20A□A	30A□A	44A□A	55A□A	75A□A	1AA□A	1EA□A
Rated Output*1	kW (HP)	0.45 (0.6)	0.85 (1.1)	1.3 (1.7)	1.8 (2.4)	2.9 (3.9)	4.4 (5.9)	5.5 (7.4)	7.5 (10)	11 (15)	15 (20)
	Rated Torque*1*2	N·m	2.84	5.39	8.34	11.5	18.6	28.4	35.0	48.0	70.0
lb·in		25	48	74	102	165	252	310	425	620	845
Instantaneous Peak Torque*1	N·m	8.92	13.8	23.3	28.7	45.1	71.1	87.6	119	175	224
	lb·in	79	122	207	254	404	630	775	1050	1550	1988
Rated Current*1	A (rms)	3.8	7.1	10.7	16.7	23.8	32.8	42.1	54.7	58.6	78.0
Instantaneous Max Current*1	A (rms)	11	17	28	42	56	84	110	130	140	170
Rated Speed*1	r/min	1500									
Instantaneous Max Speed*1	r/min	3000								2000	
Torque Constant*1	N·m/A (rms)	0.82	0.83	0.84	0.73	0.83	0.91	0.88	0.93	1.25	1.32
	lb·in/A (rms)	7.3	7.3	7.4	6.5	7.3	8.0	7.8	8.2	11	11.7
Moment of Inertia [J _M]	kg·m ² × 10 ⁻⁴	7.24	13.9	20.5	31.7	46.0	67.5	89.0	125	281	315
	lb·in·s ² × 10 ⁻³	6.41	12.3	18.2	28.1	40.7	59.8	78.8	111	249	279
Rated Power Rate*1	kW/s	11.2	20.9	33.8	41.5	75.3	120	137	184	174	289
Rated Angular Acceleration*1	rad/s ²	3930	3880	4060	3620	4050	4210	3930	3850	2490	3030

Servomotor Model: SGMG-		05A□A	09A□A	13A□A	20A□A	30A□A	44A□A	55A□A	75A□A	1AA□A	1EA□A
Inertia Time Constant	ms	5.1	3.1	2.8	2.1	1.9	1.3	1.3	1.1	1.2	0.98
Inductive Time Constant	ms	5.1	5.3	6.3	12.5	12.5	15.7	16.4	18.4	22.6	27.2

* 1. These items and torque-motor speed characteristics are in combination with an SGDB SERVOPACK and at an armature winding temperature of 20°C.

* 2. These characteristics are for a Servomotor with one of the following heat sink (steel plate) attached for cooling.

05A□A to 13A□A Servomotor: 400 × 400 × 20 mm (15.75 × 15.75 × 0.79 in) W × H × D

20A□A to 75A□A Servomotor: 550 × 550 × 30 mm (21.65 × 21.65 × 1.18 in) W × H × D

1AA□A Servomotor: 650 × 650 × 35 mm (25.59 × 25.59 × 1.38 in) W × H × D

IMPORTANT

The ratings and specifications shown on the previous page are for standard Servomotors.

For Servomotors with holding brakes, add the values in the following table to the moment of inertia values in the above table. Other characteristics may also change slightly.

Servomotor Model: SGMG			05A□A	09A□A	13A□A	20A□A	30A□A	44A□A	55A□A	75A□A	1AA□A	1EA□A
With Holding Brake 90 VDC	Added Moment of Inertia	kg·m ² ×10 ⁻⁴	1.85			7.75			7.75		13.2	37.5
		oz·in·s ² ×10 ⁻³	26			110			110		187	532
	Static Friction Torque	N·m (oz·in)	4.41 (624)	12.7 (1798)		43.1 (6103)			72.6 (10280)		84.3 (11937)	114.7 (16242)

■ SGMG Servomotor (Rated Motor Speed of 1500 r/min)
Torque-Motor Speed Characteristics

SGMG-05A □A

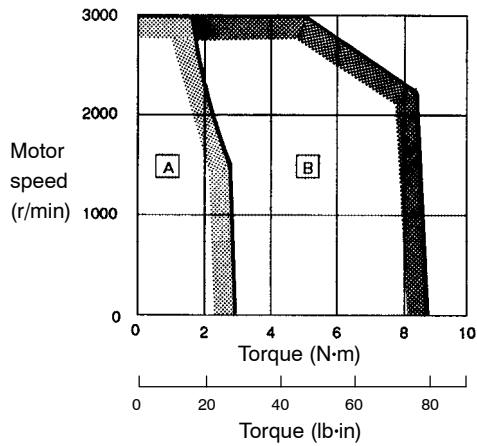

SGMG-09A □A

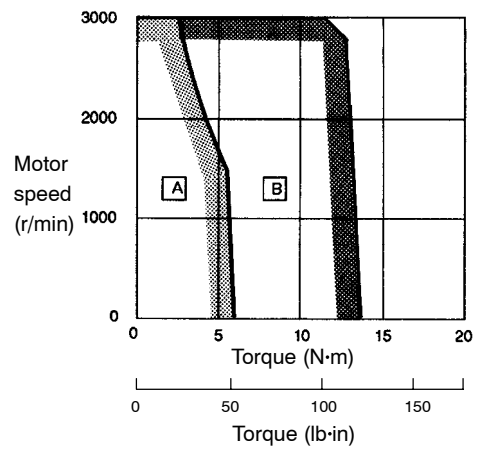

SGMG-13A □A

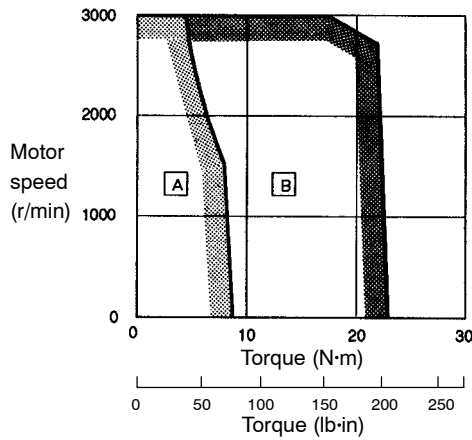

SGMG-20A □A

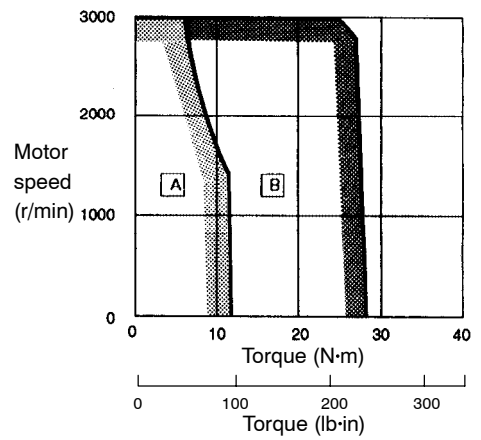

SGMG-30A □A

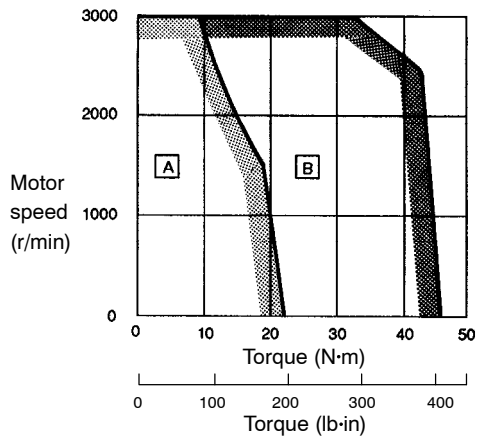

SGMG-44A □A

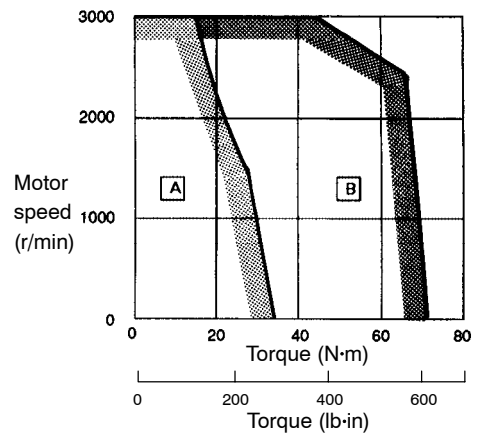

□A : Continuous Duty Zone
□B : Intermittent Duty Zone

2

SGMG-55A □ A

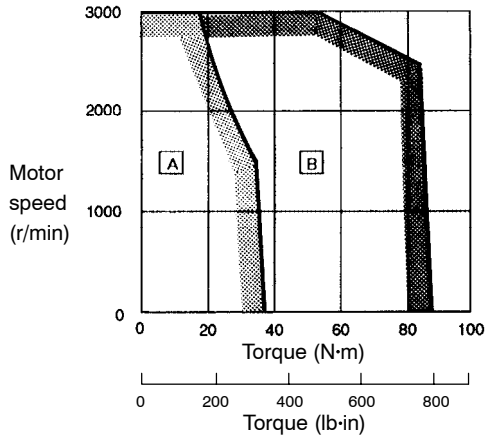

SGMG-75A □ A

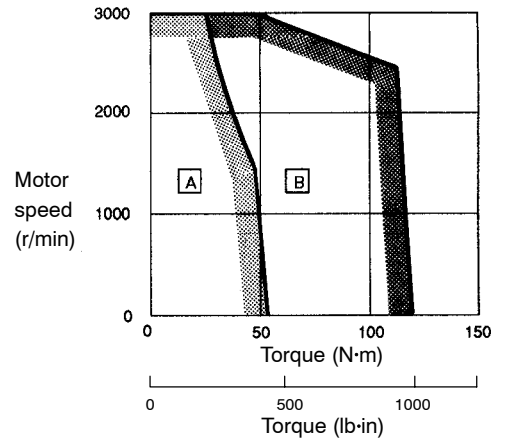

SGMG-1AA □ A

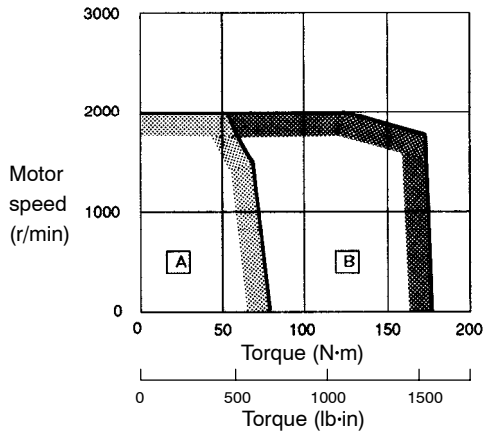

SGMG-1EA □ A

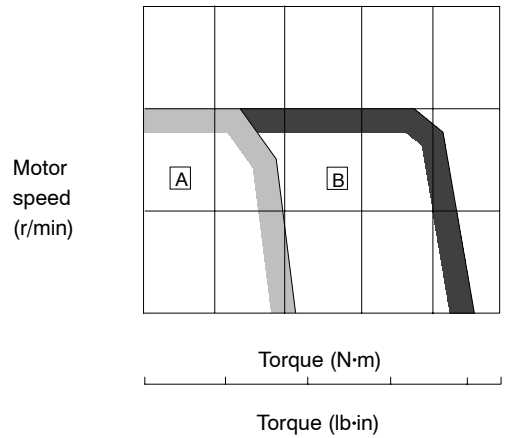

- A** : Continuous Duty Zone
- B** : Intermittent Duty Zone

2.2 Ratings and Specifications of SGMG Servomotors for Rated Speed 1000 r/min

2.2.1 Ratings and Specifications

- Time Rating: Continuous
- Enclosure: Totally enclosed, self cooled, IP67 (except shaft-through section)
- Excitation: Permanent magnet
- Insulation Class: Class F
- Drive Method: Direct drive
- Vibration Class: 15 μ m or below
- Ambient Temperature: 0 to 40°C
- Mounting: Flange method
- Withstand Voltage: 1500 VAC
- Ambient Humidity: 20% to 80% (with no condensation)
- Insulation Resistance: 500 VDC, 10 M Ω min.

Table 2.2 Ratings and Specifications of SGMG Servomotors for Rated Speed 1000 r/min

Servomotor Model: SGMG-		03A□B	06A□B	09A□B	12A□B	20A□B	30A□B	44A□B	60A□B
Rated Output*1	kW (HP)	0.3 (0.4)	0.6 (0.8)	0.9 (1.2)	1.2 (1.6)	2.0 (2.7)	3.0 (4.0)	4.4 (5.9)	6.0 (8.0)
Rated Torque*1*2	N·m	2.84	5.68	8.62	11.5	19.1	28.4	41.9	57.2
	lb·in	25	50	76	102	169	252	372	508
Instantaneous Peak Torque*1	N·m	7.17	14.1	19.3	28.0	44.0	63.7	107	129
	lb·in	63	125	171	248	390	564	947	1140
Rated Current*1	A (rms)	3.0	5.7	7.6	11.6	18.5	24.8	32.9	46.9
Instantaneous Max Current*1	A (rms)	7.3	13.9	16.6	28	42	56	84	110
Rated Speed*1	r/min	1000							
Instantaneous Max Speed*1	r/min	2000							
Torque Constant*1	N·m/A (rms)	1.03	1.06	1.21	1.03	1.07	1.19	1.34	1.26
	lb·in/A (rms)	9.12	9.38	10.7	9.12	9.47	10.5	11.9	11.2
Moment of Inertia [J _M]	kg·m ² ×10 ⁻⁴	7.24	13.9	20.5	31.7	46.0	67.5	89.0	125
	lb·in·s ² ×10 ⁻³	6.41	12.3	18.2	28.1	40.7	59.8	78.8	111
Rated Power Rate*1	kW/s	11.2	23.2	36.3	41.5	79.4	120	198	262
Rated Angular Acceleration*1	rad/s ²	3930	4080	4210	3620	4150	4210	4710	4590
Inertia Time Constant	ms	5.1	3.8	2.8	2.0	1.7	1.4	1.3	1.1
Inductive Time Constant	ms	5.1	4.7	5.7	13.5	13.9	15.5	14.6	16.5

* 1. These items and torque-motor speed characteristics are quoted in combination with a SGDB SERVOPACK at an armature winding temperature of 20°C.

* 2. These characteristics are for a Servomotor with one of the following heat sink (steel plate) attached for cooling.

03A□B to 09A□B Servomotor: 400 × 400 × 20 mm (15.75 × 15.75 × 0.79 in) W × H × D

12A□B to 60A□B Servomotor: 550 × 550 × 30 mm (21.65 × 21.65 × 1.18 in) W × H × D

IMPORTANT

The ratings and specifications shown on the previous page are for standard Servomotors.

For Servomotors with holding brakes, add the values in the following table to the moment of inertia values in the above table. Other characteristics may also change.

Servomotor Model: SGMG			03A□B	06A□B	09A□B	12A□B	20A□B	30A□B	44A□B	60A□B
With Holding Brake 90 VDC	Added Moment of Inertia	$\text{kg}\cdot\text{m}^2 \times 10^{-4}$	1.85			7.75			7.75	
		$\text{oz}\cdot\text{in}\cdot\text{s}^2 \times 10^{-3}$	26.2			110			110	
	Static Friction Toque	N·m (oz·in)	4.41 (624)	12.7 (1798)		43.1 (6103)			72.6 (10280)	

■ SGMG Servomotor (Rated Motor Speed of 1000 r/min)
Torque-Motor Speed Characteristics

SGMG-03A□B

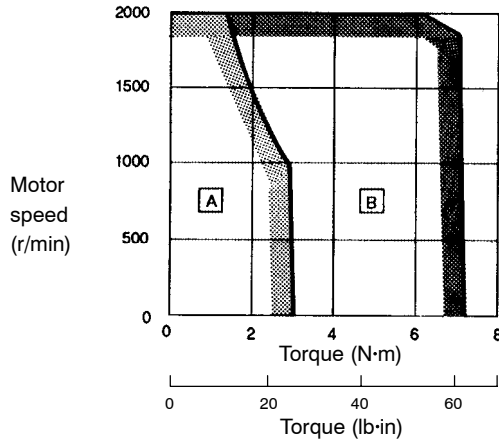

SGMG-06A□B

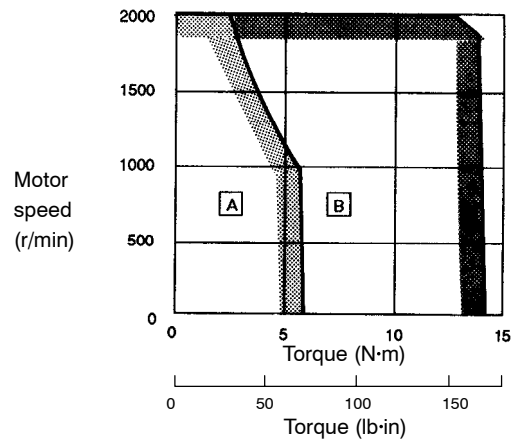

SGMG-09A□B

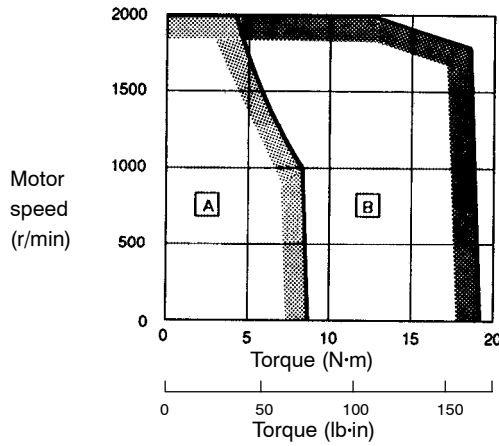

SGMG-12A□B

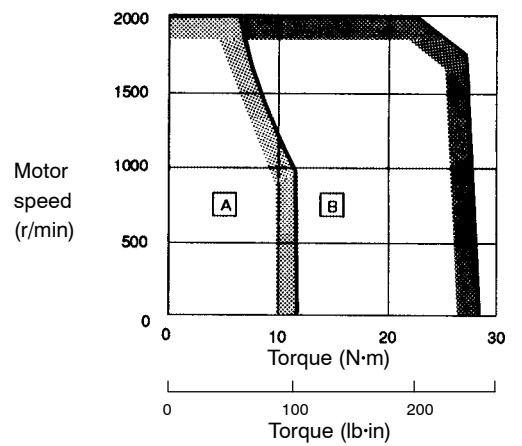

SGMG-20A□B

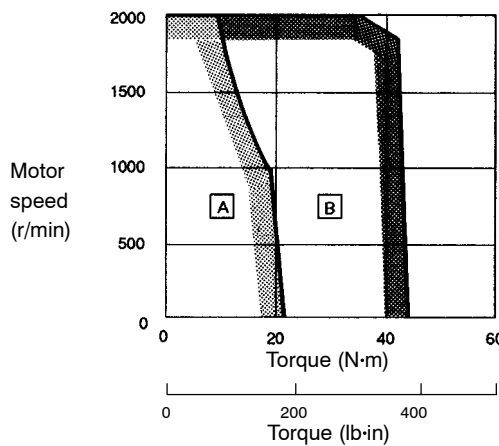

SGMG-30A□B

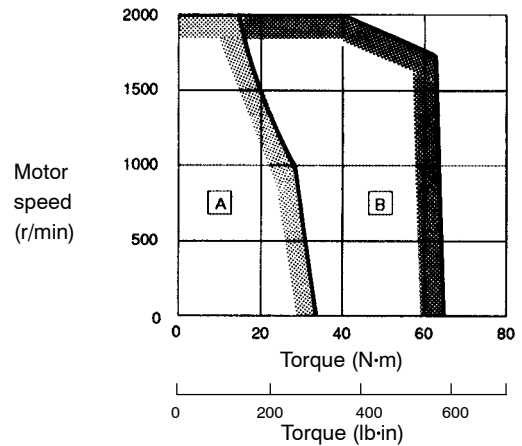

□A : Continuous Duty Zone
□B : Intermittent Duty Zone

2

SGMG-44A□B

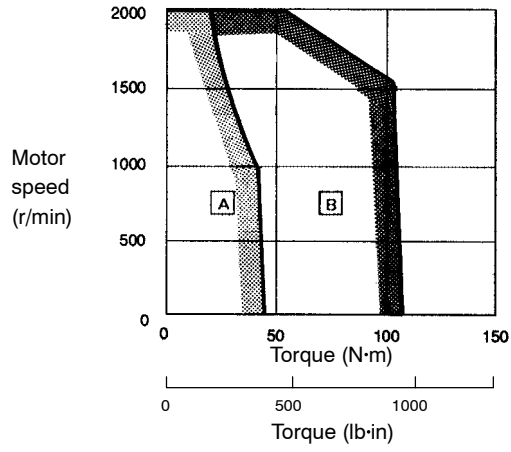

SGMG-60A□B

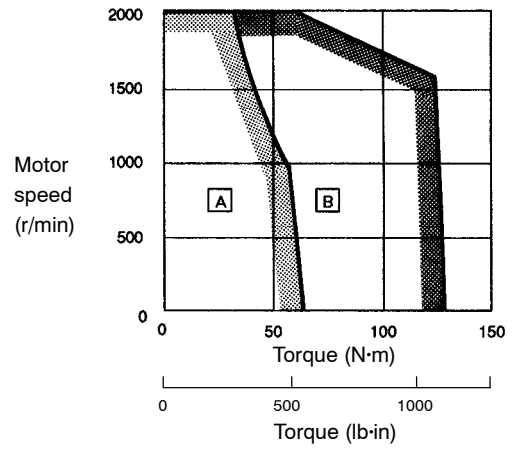

- A : Continuous Duty Zone
- B : Intermittent Duty Zone

2.3 SGMS Servomotor Ratings and Specifications

2.3.1 Ratings and Specifications

- Time Rating: Continuous
- Enclosure: Totally enclosed, self cooled, IP67 (except shaft-through section)
- Excitation: Permanent magnet
- Insulation Class: Class F
- Drive Method: Direct drive
- Vibration Class: 15 μ m or below
- Ambient Temperature: 0 to 40°C
- Mounting: Flange method
- Withstand Voltage: 1500 VAC
- Ambient Humidity: 20% to 80% (with no condensation)
- Insulation Resistance: 500 VDC, 10 M Ω min.

Table 2.3 SGMS Servomotor Ratings and Specifications

Servomotor Model: SGMS-		10A□A	15A□A	20A□A	30A□A	40A□A	50A□A
Rated Output* ¹	kW (HP)	1.0 (1.3)	1.5 (2.0)	2.0 (2.7)	3.0 (4.0)	4.0 (5.4)	5.0 (6.7)
Rated Torque* ^{1*2}	N·m	3.18	4.9	6.36	9.8	12.6	15.8
	lb·in	28.2	43	56.4	87	112	140
Instantaneous Peak Torque* ¹	N·m	9.54	14.7	19.1	29.4	37.8	47.6
	lb·in	84.4	130	169	260	336	422
Rated Current* ¹	A (rms)	5.7	9.5	12.4	18.8	24.3	28.2
Instantaneous Max Current* ¹	A (rms)	17	28	42	56	77	84
Rated Speed* ¹	r/min	3000					
Instantaneous Max Speed* ¹	r/min	4500					
Torque Constant* ¹	N·m/A (rms)	0.636	0.573	0.559	0.573	0.55	0.61
	lb·in/A (rms)	5.6	5.1	5.0	5.1	4.9	5.4
Moment of Inertia [J _M]	kg·m ² ×10 ⁻⁴	1.74	2.47	3.19	7.00	9.60	12.3
	lb·in·s ² ×10 ⁻³	1.54	2.19	2.82	6.20	8.50	10.9
Rated Power Rate* ¹	kW/s	57.9	97.2	127	137	166	202
Rated Angular Acceleration* ¹	rad/s ²	18250	19840	19970	14000	13160	12780
Inertia Time Constant	ms	0.87	0.71	0.58	0.74	0.60	0.57
Inductive Time Constant	ms	7.1	7.7	8.3	13.13	14.1	14.7

* 1. These items and torque-motor speed characteristics are quoted in combination with a SGDB SERVOPACK at an armature winding temperature of 20°C.

* 2. These characteristics are for a Servomotor with one of the following heat sink (steel plate) attached for cooling.
 10A□A to 20A□A Servomotor: 300 × 300 × 12 mm (11.81 × 11.81 × 0.47 in) W × H × D
 30A□A to 50A□A Servomotor: 400 × 400 × 20 mm (15.75 × 15.75 × 0.79 in) W × H × D

IMPORTANT

The ratings and specifications shown on the previous page are for standard Servomotors.

For Servomotors with holding brakes, add the values in the following table to the moment of inertia values in the above table. Other characteristics may also change.

Servomotor Model: SGMG			10A□A	15A□A	20A□A	30A□A	40A□A	50A□A
With Holding Brake 90 VDC	Added Moment of Inertia	$\text{kg}\cdot\text{m}^2 \times 10^{-4}$	0.215			1.85		
		$\text{oz}\cdot\text{in}\cdot\text{s}^2 \times 10^{-3}$	3.05			26.2		
	Static Friction Torque	N·m (oz·in)	7.84 (1110)			20 (2832)		

■ **SGMS Servomotor Torque Motor Speed Characteristics**

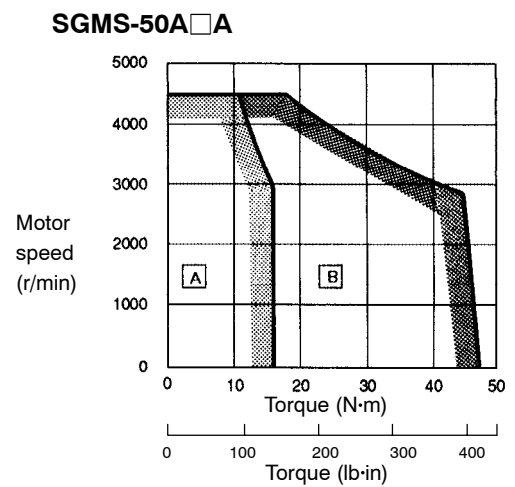
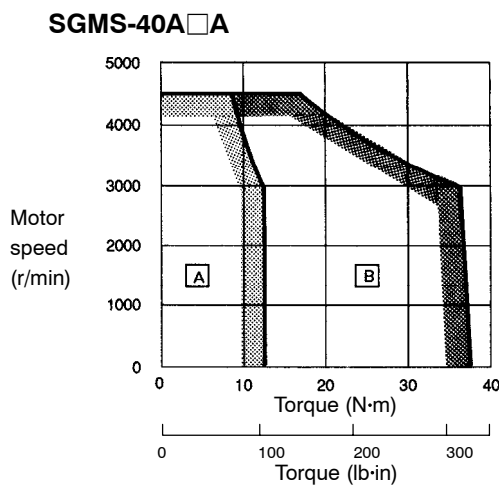
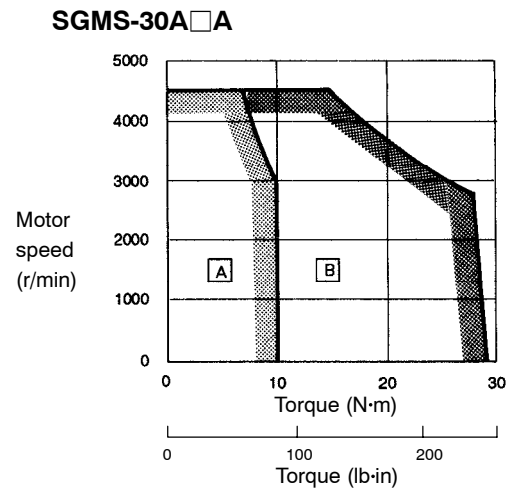
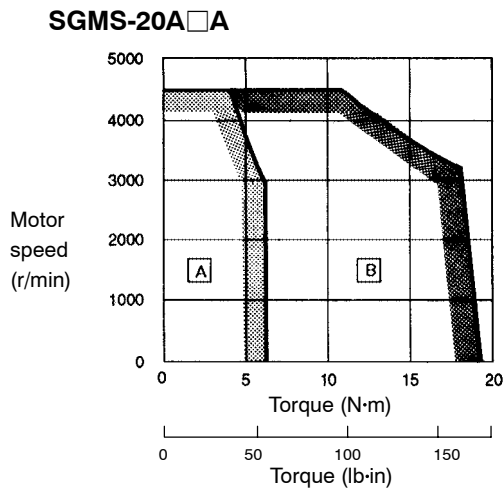
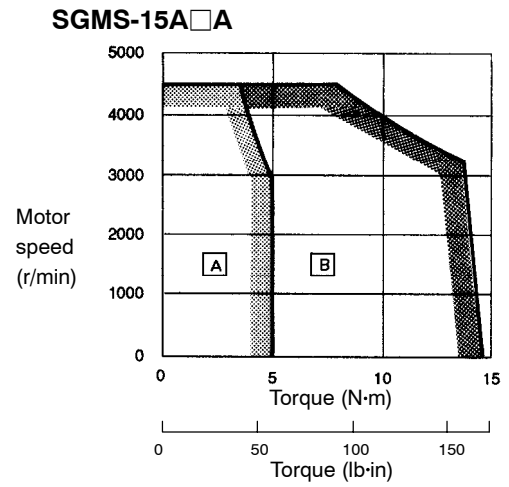
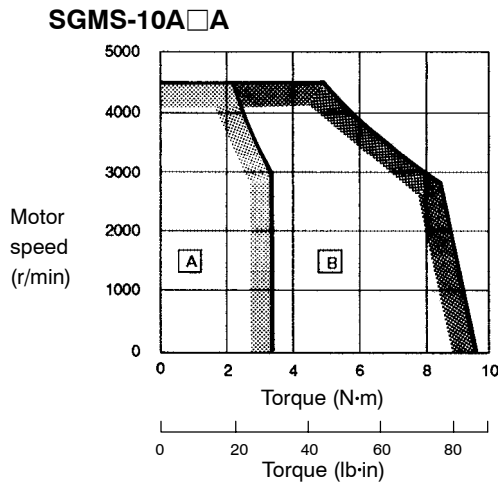

□ A : Continuous Duty Zone
 □ B : Intermittent Duty Zone

2

2.4 SGMD Servomotor Ratings and Specifications (with Holding Brake)

2.4.1 Ratings and Specifications

- Time Rating: Continuous
- Enclosure: Totally enclosed, self cooled, IP67 (except shaft-through section)
- Excitation: Permanent magnet
- Insulation Class: Class F
- Drive Method: Direct drive
- Vibration Class: 15 μm or below
- Ambient Temperature: 0 to 40°C
- Mounting: Flange method
- Withstand Voltage: 1500 VAC
- Ambient Humidity: 20% to 80% (with no condensation)
- Holding Brake: 90 VDC
Static wear torque: 3kgf·m
- Insulation Resistance: 500 VDC, 10 M Ω min.

Table 2.4 SGMD Servomotor Ratings and Specifications (with Holding Brake)

Servomotor Model: SGMD-		22A□AAB	32A□AAB	40A□AAB
Rated Output*1	kW (HP)	2.2 (2.9)	3.2 (4.3)	4.0 (5.4)
Rated Torque*1*2	N·m	10.5	15.3	19.1
	lb·in	93	135	169
Instantaneous Peak Torque*1	N·m	36.7	53.5	66.9
	lb·in	326	474	592
Rated Current*1	A (rms)	15.7	20.9	22.8
Instantaneous Max Current*1	A (rms)	54	73	77
Rated Speed*1	r/min	2000		
Instantaneous Max Speed*1	r/min	3000		
Torque Constant*1	N·m/A (rms)	0.72	0.78	0.93
	lb·in/A (rms)	6.4	6.9	8.2
Moment of Inertia [J _M]	kg·m ² ×10 ⁻⁴	51.0	68.6	86.2
	lb·in·s ² ×10 ⁻³	45.2	60.8	76.4
Rated Power Rate*1	kW/s	21.6	34.1	42.3
Rated Angular Acceleration*1	rad/s ²	2060	2230	2220
Inertia Time Constant	ms	3.3	3.3	2.0
Inductive Time Constant	ms	16.2	16.2	17.8

* 1. These items and torque-motor speed characteristics are quoted in combination with a SGDB SERVOPACK at an armature winding temperature of 20°C.

* 2. These characteristics are for a Servomotor with one of the following heat sink (steel plate) attached for cooling.
 22A□AAB to 40A□AAB Servomotor: 650 × 650 × 35 mm
 (25.59 × 25.59 × 1.38 in) W × H × D

■ **SGMD Servomotor Torque Motor Speed Characteristics**

SGMD-22A□AAB

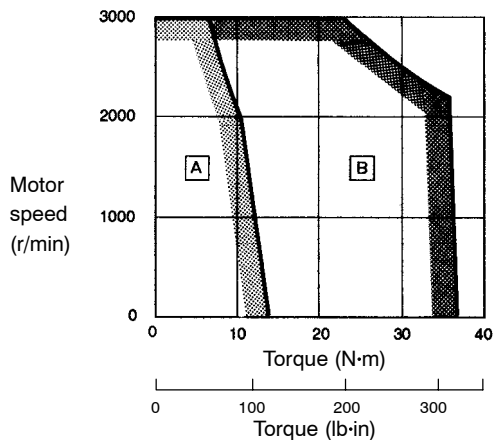

SGMD-32A□AAB

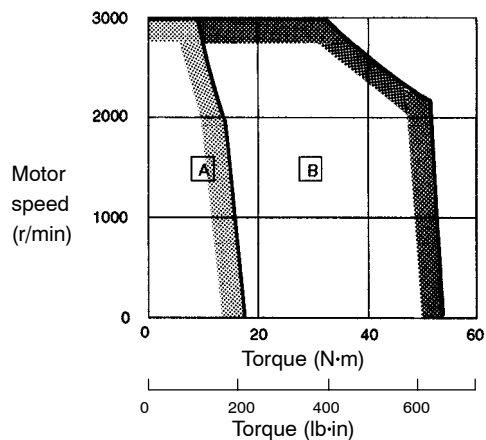

SGMD-40A□AAB

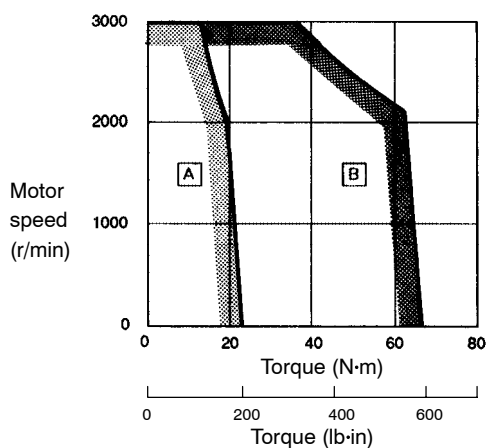

- A** : Continuous Duty Zone
- B** : Intermittent Duty Zone

2.5 SGMP Servomotor (1.5 kW) Ratings and Specifications

2.5.1 Ratings and Specifications

- Time Rating: Continuous
- Enclosure: Totally enclosed, self cooled
- Excitation: Permanent magnet
- Insulation Class: Class B
- Drive Method: Direct drive
- Vibration Class: 15 μm or below
- Ambient Temperature: 0 to 40°C
- Mounting: Flange method
- Withstand Voltage: 1500 VAC per 1 min
- Ambient Humidity: 20% to 80% (with no condensation)
- Insulation Resistance: 500 VDC, 10 M Ω min.

Table 2.5 SGMP Servomotor (1.5 kW) Ratings and Specifications

Servomotor Model: SGMP-		15A
Rated Output *	kW (HP)	1.5 (2.0)
Rated Torque *	N·m	4.77
	lb·in	42.2
Instantaneous Peak Torque *	N·m	14.3
	lb·in	126.6
Rated Current *	A (rms)	7.5
Instantaneous Max. Current *	A (rms)	28.0
Rated Speed *	r/min	3000
Instantaneous Max. Speed *	r/min	4500
Torque Constant *	N·m/A (rms)	0.687
	lb·in/A (rms)	6.08
Moment of Inertia [J_M]	$\text{kg}\cdot\text{m}^2 \times 10^{-4}$	4.03
	$\text{oz}\cdot\text{in}\cdot\text{s}^2 \times 10^{-3}$	3.57
Rated Power Rate *	kW/s	56.6
Rated Angular Acceleration *	rad/s ²	11800
Inertia Time Constant	ms	0.5
Inductive Time Constant	ms	22

* These items and torque-motor speed characteristics are quoted in combination with a SGDB SERVOPACK at an armature winding temperature of 20 °C.

Note These characteristics are for a Servomotor with a 300 × 300 × 12 mm (9.84 × 9.84 × 0.24 in.) W × H × D heat sink attached for cooling.

IMPORTANT

The ratings and specifications shown above are for standard Servomotors.

For Servomotors with holding brakes, add the values in the following table to the moment of inertia values in the above table. Other characteristics may also change.

Servomotor Model: SGMG			15A
With Holding Brake, 90 VDC	Added Moment of Inertia	kg·m ² × 10 ⁻⁴	0.875
		oz·in·s ² × 10 ⁻³	12.4
	Static Friction Torque	N·m (oz·in)	7.45 (1055)

■ SGM Servomotor (1.5 kW) Torque Motor Speed Characteristics

2

SGMP-15A

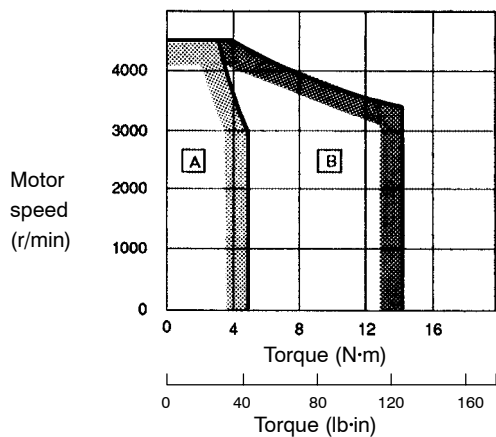

A : Continuous Duty Zone
 B : Intermittent Duty Zone

2.6 SERVOPACK Ratings and Specifications

2.6.1 Ratings and Specifications

The ratings and specifications for the SGDB SERVOPACK are shown below. Refer to them as required when selecting a SERVOPACK. Refer to the specifications listed in the table for combination with the appropriate model of Servomotor.

Table 2.6 SERVOPACK and Applicable Servomotors

SERVOPACK SGDB-		05	10	15	20	30	50	60	75	1A	1E	
Applicable Servomotor	SGMG- (1500 r/min)	05A	09A	13A	20A	30A	44A	55A	75A	1AA	1EA	
	SGMG- (1000 r/min)	03A	06A 09A	12A	20A	30A	44A	60A	—	—	—	
	SGMS-	—	10A	15A	20A	30A	40A 50A	—	—	—	—	
	SGMD-	—	—	—	—	22A	32A 40A	—	—	—	—	
	SGMP-	04A	08A	15A	—	—	—	—	—	—	—	
Basic Specifications	Power Supply	Main Circuit *1	Three-phase, 200 to 230 VAC $^{+10}_{-15}$ %, 50/60 Hz									
		Control Circuit *1	Single-phase, 200 to 230 VAC $^{+10}_{-15}$ %, 50/60 Hz									
	Control Method		Three-phase, full-wave rectification IGBT-PWM (sine-wave driven)									
	Feedback		Incremental encoder, absolute encoder									
	Conditions	Operating Temp. ² / Storage Temp. *2		0 to 55°C/-20 to 85°C								
		Ambient/Storage Humidity		90% RH or less (with no condensation)								
		Vibration, Shock Resistance		4.9 m/s ² /19.6 m/s ² (16.08 ft/s ² /64.30 ft/s ²)								
	Configuration		Base mounted (duct ventilation with optional specification)									
Approx. mass [kg (lb)]		4 (8.82)			5 (11.0)		8 (17.6)	15 (33.1)		23 (50.7)		
Reference Method	Operation Specifications		Positioning by serial commands									
	Reference Input		MECHATROLINK communication, 4 Mbps, 2 ms cycle Serial Commands: Operation, movement (positions/speeds), interpolation, synchronization, parameter reads, parameter writes, and monitor outputs									
Position Control Functions		<ul style="list-style-type: none"> • Online speed/position loop gain changes (by changing parameter). • Setting acceleration/deceleration method (linear, exponential, or S-curve) (by specifying a command). • Conversion function for positioning units and feedback pulses. • Feedforward compensation and bias setting (by changing user constant). • Positioning near and completed outputs (read via a command). 										

SERVOPACK SGDB-		05	10	15	20	30	50	60	75	1A	1E
Monitoring		Using the monitor command, monitoring of various positions, speeds, position error torque, SERVOPACK status, and alarm contents is possible.									
I/O Signals	Sequence Inputs	Forward overtravel prohibit (P-OT), reverse overtravel prohibit (N-OT), external latch (EXT), and zero point return deceleration limit switch (DEC)									
	Sequence Outputs	Break interlock (BK) and Servo alarm (ALM)									
Built-in Functions	Dynamic Brake (DB)	Incorporating DB that is activated for main power OFF, Servo alarms, and overtravel									
	Regenerative Processing	Built in. For 60 to 1A models, an external regenerative resistor must be mounted.									
	Overtravel (OT)	Motor is stopped by deceleration stopping when P-OT/N-OT or soft overtravel (P-SOT/N-SOT) is activated.									
	Protective Functions	Overcurrent, ground, overload, overvoltage, overspeed, overrun, origin error, hardware error, encoder error, excessive position error, and MECHATROLINK communication error									
	Indicators	LED of POWER, ALARM, CHARGE, MECHATROLINK communication									
	Others	Not available for Digital Operator or personal computer.									

2

2.7 Combined Specifications

The following specifications for combinations of SGDB SERVOPACKS and SGMG, SGMS, SGMD and SGMP Servomotors.

2.7.1 Standard Combinations

Table 2.7 SERVOPACK and Servomotor Combination Specifications.

SGMG Series	SERVOPACK Model SGDB-		05AN	10AN		15AN	20AN	30AN	50AN		60AN		
	Appliable Servomotor	Model SGMG-		03A□ B	06A□ B	09A□ B	12A□ B	20A□ B	30A□ B	44A□B		60A□B	
Motor Capacity (kW)			0.3	0.6	0.9	1.2	2.0	3.0	4.4		6.0		
Rated/Max. Motor Speed			1000/2000 r/min										
Applicable Encoder			Standard: Incremental encoder at 8192 P/R										
Allowable Load Inertia* (kg·m ² ×10 ⁻⁴) (oz·in·s ² ×10 ⁻³)			36.2 (513)	69.5 (984)	103 (1459)	159 (2252)	230 (3257)	338 (4786)	445 (6302)		625 (8851)		
Continuous Output Current A (rms)			3.0	5.7	7.6	11.6	18.5	24.8	32.9		46.9		
Maximum Output Current A (rms)			7.3	13.9	16.6	28	42	56	84		110		
SGMG Series	SERVOPACK Model SGDB-		05AN	10AN	15AN	20AN	30AN	50AN	60AN	75AN	1AAN	1EAN	
	Appliable Servomotor	Model SGMG-		05A□ A	09A□ A	13A□ A	20A□ A	30A□ A	44A□ A	55A□ A	75A□ A	1AA- □A	1EA□
Motor Capacity (kW)			0.45	0.85	1.3	1.8	2.9	4.4	5.5	7.5	11	15	
Rated/Max. Motor Speed			1500/3000 r/min									1500/2000 r/min	
Applicable Encoder			Standard: Incremental encoder at 8192 P/R										
Allowable Load Inertia* J _L (kg·m ² ×10 ⁻⁴) (oz·in·s ² ×10 ⁻³)			36.2 (513)	69.5 (984)	103 (1459)	159 (2252)	230 (3257)	338 (4786)	445 (6302)	625 (8851)	1405 (19896)	1575 (22304)	
Continuous Output Current A (rms)			3.8	7.1	10.7	16.7	23.8	32.8	42.1	54.7	58.6	78.6	
Maximum Output Current A (rms)			11	17	28	42	56	84	110	130	140	170	

Ratings and Characteristics

2.7.1 Standard Combinations

SGMD Series	SERVOPACK Model SGDB-		30AN	50AN	
	Applicable Servomotor	Model SGMD-		22A□A	32A□A
Motor Capacity (kW)			2.2	3.2	4.0
Rated/Max. Motor Speed			2000/3000 r/min		
Applicable Encoder			Standard: Absolute encoder at 1024 P/R		
Allowable Load Inertia* J_L ($\text{kg}\cdot\text{m}^2\times 10^{-4}$) ($\text{oz}\cdot\text{in}\cdot\text{s}^2\times 10^{-3}$)			255 (3611)	343 (4857)	431 (6103)
Continuous Output Current A (rms)			15.7	20.9	22.8
Maximum Output Current A (rms)			54	73	77



* The allowable load inertia is five times the SGMG and SGMD Servomotor's moment of inertia.

SERVOPACK Model SGDB-		10AN	15AN	20AN	30AN	50AN	
Appli- cable Servo- motor	Model SGMS-	10A□A	15A□A	20A□A	30A□A	40A□A	50A□A
	Motor Capacity (kW)	1.0	1.5	2.0	3.0	4.0	5.0
	Rated/Max. Motor Speed	3000/4500 r/min					
	Applicable Encoder	Standard: Incremental encoder at 4096 P/R					
	Allowable Load Inertia* J_L ($\text{kg}\cdot\text{m}^2\times 10^{-4}$) ($\text{oz}\cdot\text{in}\cdot\text{s}^2\times 10^{-3}$)	8.7 (123)	12.4 (176)	16.0 (227)	35.0 (496)	48.0 (680)	62.0 (878)
Continuous Output Current A (rms)	5.7	9.5	12.4	18.8	24.3	28.2	
Maximum Output Current A (rms)	17	28	42	56	77	84	
SERVOPACK Model SGDB-		15AN					
Appli- cable Servo- motor	Model SGMP-	15A□					
	Motor Capacity (kW)	1.5					
	Rated/Max. Motor Speed	3000/4500 r/min					
	Applicable Encoder	Standard: Incremental encoder at 2048 P/R					
	Allowable Load Inertia* J_L ($\text{kg}\cdot\text{m}^2\times 10^{-4}$) ($\text{oz}\cdot\text{in}\cdot\text{s}^2\times 10^{-3}$)	20.2 (286)					
Continuous Output Current A (rms)	7.5						
Maximum Output Current A (rms)	23.0						

* The allowable load inertia is five times the SGMG and SGMD Servomotor's moment of inertia.

2.7.2 Peripheral Device Combinations

Table 2.8 Peripheral Device Combinations

SERVOPACK Model	Applicable Servomotor Model	Power Supply Capacity per SERVOPACK* ¹ (kVA)	MCCB or Fuse Power Supply Capacity* ² (A)	Applicable Noise Filter (Reference Filter Structure)	Recommended Noise Filter* ³	Power ON/OFF Contactor
SGDB-05AN	SGMG-03A□B	0.65	5	(Applicable) 	LF-310 (10 A)	HI-15E5 (30 A)
	SGMG-05A□A	1.1				
	SGMP-04A					
	SGM-04A					
SGDB-10AN	SGMG-06A□B	1.5	8		LF-315 (15 A)	
	SGMG-09A□A	2.0				
	SGMG-09A□B					
	SGMS-10A□A					
	SGMP-08A					
	SGM-08A					
SGDB-15AN	SGMG-13A□A	2.5	10			
	SGMG-12A□B					
	SGMS-15A□A					
	SGMP-15A					
SGDB-20AN	SGMG-20A□A	4.0	12	(Not applicable) 	LF-320 (20 A)	HI-18E (35 A)
	SGMG-20A□B					
	SGMS-20A□A					
SGDB-30AN	SGMG-30A□A	5.0	18		LF-330 (30 A)	
	SGMG-30A□B					
	SGMS-30A□A					
	SGMD-22A□A					
SGDB-50AN	SGMD-32A□A	7.0	24		LF-340 (40 A)	
	SGMG-44A□A					
	SGMG-44A□B					
	SGMS-40A□A	7.5	28			HI-25E (50 A)
	SGMD-40A□A					
	SGMS-50A□A					
SGDB-60AN	SGMG-55A□A	12.5	32		LF-350 (50 A)	
	SGMG-60A□A					
SGDB-75AN	SGMG-75A	15.0	41		LF-360 (60 A)	HI-30E (65 A)
SGDB-1AAN	SGMG-1AA	19.0	60		LF-380K (80 A)	HI-35E (65 A)
SGDB-1EAN	SGMG-1EA	30.0	80		FN258-100	HI-50E (100 A)

* 1. Values for the rated load

* 2. Shut off characteristics (at 25°C): 200%: 2 s min., 700%: 0.01 s min.

* 3. A Tokin Corp. noise filter or a SCHAFFNER noise filter (FN258-100) is recommended. Tokin Corp. noise filters are available from Yaskawa Control Co.,

3

Servodrive Characteristics

This chapter provides information on the characteristics of SERVOPACKS

3.1	Overload Characteristics	3 -2
3.2	Starting and Stopping Time	3 -3
3.3	Allowable Repeatability	3 -4
3.3.1	Allowable Repeatability as Limited by the Servomotor	3 -4
3.4	Large-amplitude Frequency Characteristics ...	3 -6
3.5	Mechanical Characteristics	3 -7
3.5.1	Mechanical Strength	3 -7
3.5.2	Allowable Radial and Thrust Load	3 -7
3.5.3	Mechanical Tolerances	3 -8
3.5.4	Direction of Motor Rotation	3 -8
3.5.5	Impact Resistance	3 -8
3.5.6	Vibration Resistance	3 -9
3.5.7	Vibration Class	3 -9

3.1 Overload Characteristics

The SERVOPACK has a built-in overload protective function to protect the SERVOPACK and Servomotor from overload. Allowable power for the SERVOPACK is therefore limited by the overload protective function as shown in *Fig. 3.1*.

The overload detection level quoted under hot start conditions at a motor ambient temperature of 40°C cannot be modified.

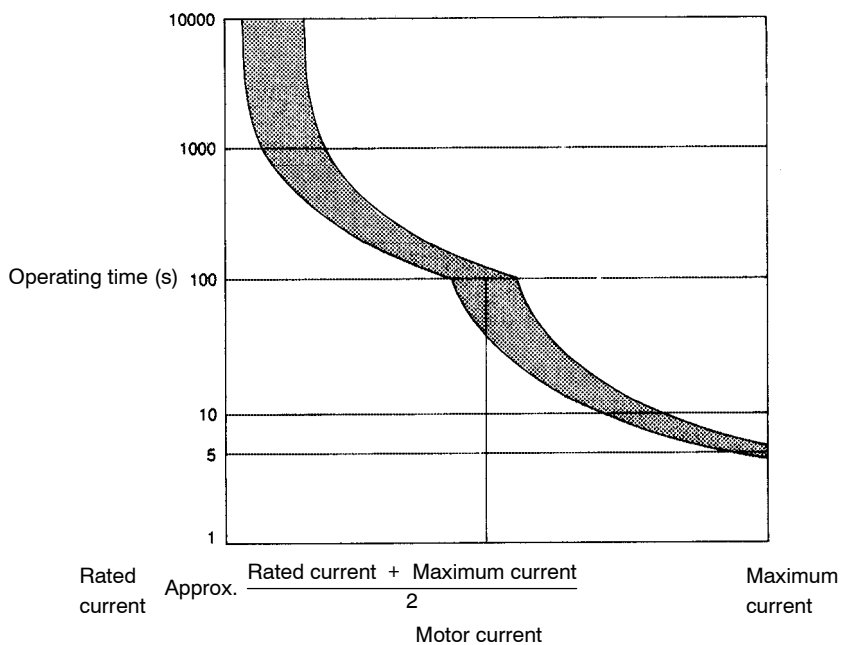

Figure 3.1 Overload Characteristics

3.2 Starting and Stopping Time

The motor starting (t_r) and stopping time (t_f) with a constant load are calculated using the following equations. Motor viscous torque and friction torque have been ignored.

$$\text{Starting time: } t_r = 104.7 \times \frac{N_R(J_M + J_L)}{Kt \cdot I_R(\alpha - \beta)} [\text{ms}]$$

$$\text{Stopping time: } t_f = 104.7 \times \frac{N_R(J_M + J_L)}{Kt \cdot I_R(\alpha + \beta)} [\text{ms}]$$

N_R : Rated motor speed (r/min)

J_M : Motor moment of inertia (kg/m^2)...(GD²_M/4)

J_L : Load converted to shaft moment of inertia (kg/m^2)...(GD²_L/4)

T_{PM} : Maximum instantaneous motor torque obtained in combination with SERVOPACK (N·m)

T_L : Load torque (N·m)

To convert the motor current value into an equivalent torque value, use the following formula:

Motor torque constant × motor current value (effective value)

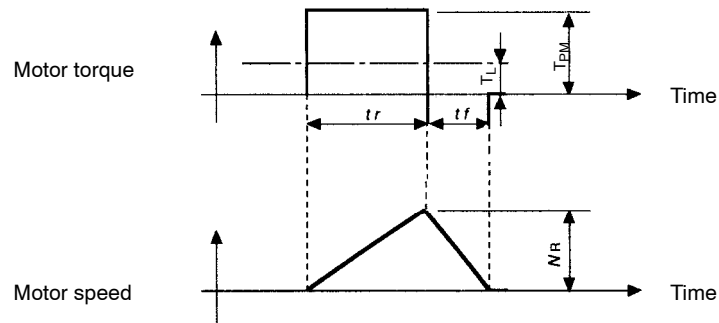

Figure 3.2 Motor Torque – Motor Speed Timing Chart

3.3 Allowable Repeatability

Running and stopping repeatability are limited by the Servomotor.

3.3.1 Allowable Repeatability as Limited by the Servomotor

Running and stopping repeatability vary with motor conditions, such as the load conditions and running time. A typical example is given below (See 3.2 “Starting and Stopping Time” for details on symbols.).

■ With Motor Idling or Stopped

The most common example is the operating cycle shown in Fig. 3.3 where rms frequency for motor armature current is lower than the rated motor current. If we assume that T is the operating cycle, then the range for T will satisfy the following equation.

$$T \geq \frac{I_P^2 (tr + tf) + I_L^2 ts}{I_R^2} \quad (s)$$

I_R : Motor rated current (A)

$\alpha = I_P/I_R$: Acceleration/deceleration current coefficient

[I_P : Acceleration/deceleration current (acceleration/deceleration current α times larger than motor rated current) (A)]

$\beta = I_L/I_R$: Load current coefficient

[I_L : Current equivalent to load torque (load current β times larger than motor rated current) (A)]

Find I_P , tr , and tf that satisfy the equation above when cycle time (T) is already known.

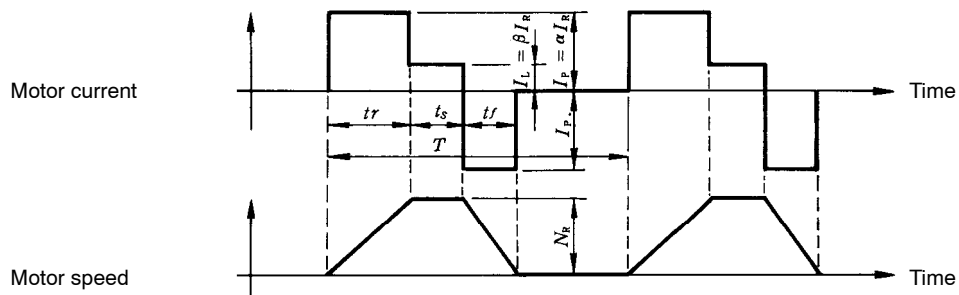

Figure 3.3 Motor Current – Motor Speed Timing Chart

■ With Motor Stopped without Idling Except during Acceleration or Deceleration

The timing chart for motor armature current and motor speed is shown in Fig. 3.4. If we assume that allowable repeatability is n , then n can be found using the equation given below.

$$n = 286.5 \times \frac{T_R}{N_R(J_M + J_L)} (1/\alpha - \beta^2/\alpha^3) \text{ [times per minute]}$$

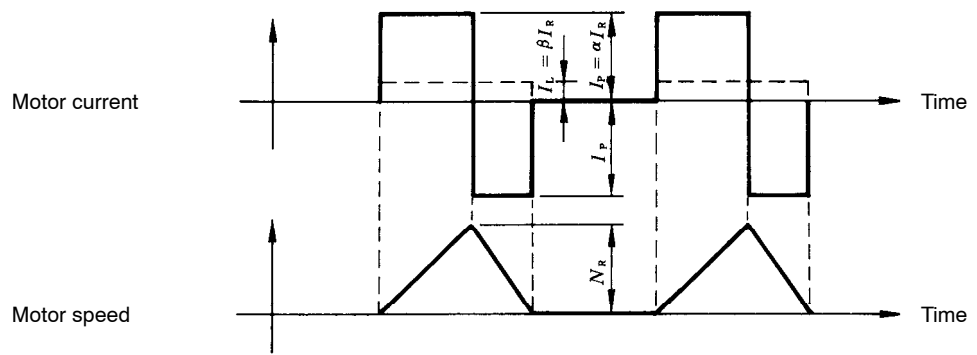

Figure 3.4 Motor Current - Motor Speed Timing Chart

■ With Motor Constantly Cycling through Acceleration, Idling, and Deceleration without Stopping

The timing chart for motor armature current and motor speed is shown in Fig 3.5. If we assume that allowable repeatability is n (times per minute), then n can be found using the equation given below.

$$n = 286.5 \times \frac{T_R}{N_R(J_M + J_L)} (1/\alpha - \beta^2/\alpha) \text{ [times per minute]}$$

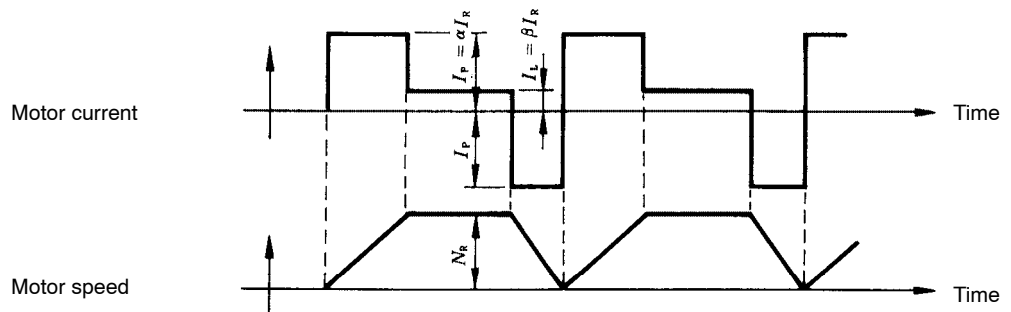

Figure 3.5 Motor Current - Motor Speed Timing Chart

3

3.4 Large-amplitude Frequency Characteristics

When looking at frequency characteristics with a SERVOPACK and Motor combination, the motor speed amplitude is limited by the peak current through the SERVOPACK. The relationship between motor speed (N) and frequency (f) is expressed using the equation given below.

$$N = 1.52 \times \frac{\alpha \cdot T_R}{(J_M + J_L)} f [r/min]$$

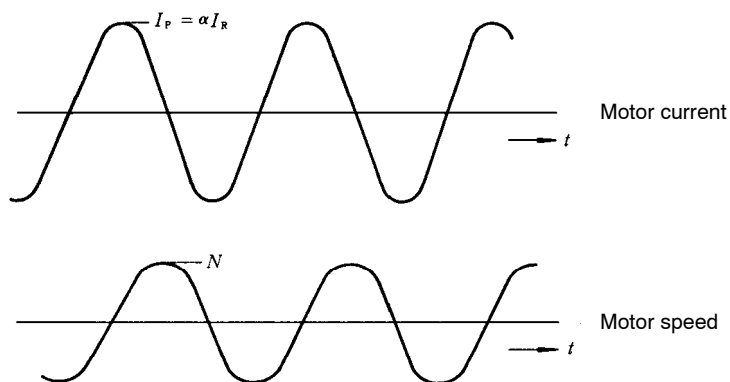

Figure 3.6 Motor Current – Motor Speed Timing Chart

3

3.5 Mechanical Characteristics

3.5.1 Mechanical Strength

An AC Servomotor can withstand instantaneous peak torque on the output shaft of up to 300% of the motor rating.

3.5.2 Allowable Radial and Thrust Load

The output shaft allowable loads of AC Servomotors are shown below.

Use mechanical designs where thrust and radial loads do not exceed the values below during motor operation.

Table 3.1 Allowable Radial Load, Allowable Thrust Load for SGM Servomotors

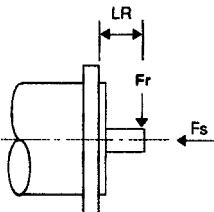
Servomotor Type	Allowable Radial Load Fr [N(lb)]	Allowable Thrust Load Fs [N(lb)]	LR [mm (in)]	Reference Diagram
SGMG-05A□A	490 (110)	98 (22)	58 (2.28)	
-09A□A	490 (110)	98 (22)		
-13A□A	686 (154)	343 (77)		
-20A□A	1176 (265)	490 (110)	79 (3.11)	
-30A□A	1470 (331)	490 (110)		
-44A□A	1470 (331)	490 (110)		
-55A□A	1764 (397)	588 (132)	113 (44.49)	
-75A□A	1764 (397)	588 (132)		
-1AA□A	1764 (397)	588 (132)	116 (4.57)	
-1EA□A	4998 (1125)	2156 (485)		
SGMG-03A□B	490 (110)	98 (22)	58 (2.28)	
-06A□B	490 (110)	98 (22)		
-09A□B	686 (154)	343 (77)		
-12A□B	1176 (265)	490 (110)	79 (3.11)	
-20A□B	1470 (331)	490 (110)		
-30A□B	1470 (331)	490 (110)		
-44A□B	1764 (397)	588 (132)	113 (44.49)	
-60A□B	1764 (397)	588 (132)		
SGMS-10A	686 (154)	196 (44)	45 (1.77)	
-15A	686 (154)	196 (44)		
-20A	686 (154)	196 (44)		
-30A	980 (221)	392 (88)	63 (2.48)	
-44A	1176 (265)	392 (88)		
-50A	1176 (265)	392 (88)		
SGMD-22A	1176 (265)	490 (110)	55 (2.17)	
-32A	1176 (265)	490 (110)		
-40A	1176 (265)	490 (110)	65 (2.56)	
SGMP-15A	490 (110)	147 (33)	35 (1.38)	

Note Radial and thrust load limit value are the sum of the loads generated by the motor torque and external loads applied to the shaft.

3.5.3 Mechanical Tolerances

Tolerances for AC Servomotor output shaft and installation are shown in *Table 3.2*.

Table 3.2 Mechanical Tolerances

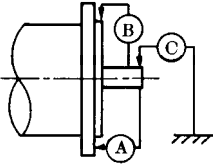
Tolerance (T.I.R.)		Reference Diagram
Perpendicularity between the flange face and output shaft (A)	0.04 mm (0.0016 in)	
Mating concentricity of flange O.D. (B)	0.04 mm (0.0016 in)	
Run-out at the end of the shaft (C)	0.02 mm (0.0008 in) 0.04 mm (0.0016 in)	

Note T.I.R. = Total Indicator Reading

3.5.4 Direction of Motor Rotation

AC Servomotor rotation when a positive direction instruction (and direction instruction) is input is counterclockwise as viewed from the load end of the shaft.

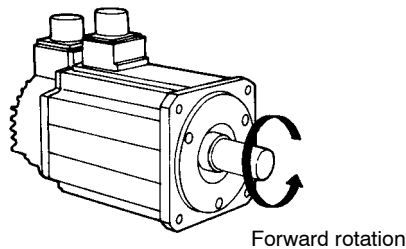

Figure 3.7 Direction of Rotation for Positive Direction Instruction Input

3.5.5 Impact Resistance

Mount the servomotor with the axis horizontal. The servomotor must withstand the following vertical impacts.

- Impact Acceleration: 490 m/s² (50 G)
 - Number of Impacts: 2
- (SGMP-15A)
- Impact Acceleration: 98 m/s² (10 G)

- Number of Impacts: 2

Since a precision detector is attached to the shaft at the end opposite the load end, do not subject the shaft to direct impact as this may damage the encoder.

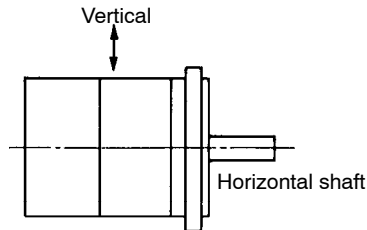

Figure 3.8 Impact Measurement

3.5.6 Vibration Resistance

The Servomotor will withstand a vibration acceleration of 24.5 m/s^2 (2.5 G) in the vertical, transverse, and longitudinal directions (See Fig. 3.9) when the axis of the Servomotor is mounted horizontally.

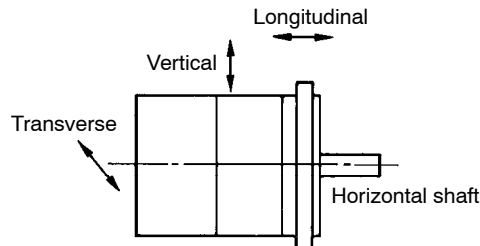

Figure 3.9 Vibration Resistance Measurement

3.5.7 Vibration Class

The vibration class of the AC Servomotor is $15 \mu\text{m}$ or below at the rated speed (See Fig. 3.10).

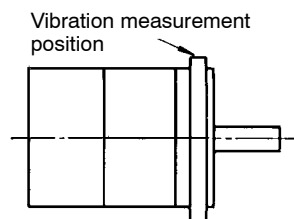

Figure 3.10 Vibration Measurement

SGM□ Servomotors have a precision encoder on the end of the shaft opposite the load. Do not apply shock directly to the shaft; direct shock can damage this encoder.

4

Configuration and Connections

This chapter provides information on the configuration and connections of Servodrives.

4.1 Internal Connection Diagram	4 -3
4.1.1 0.5 kW to 1.5 kW Servodrives	4 -3
4.1.2 2.0 kW to 3.0 kW Servodrives	4 -4
4.1.3 5.0 kW Servodrive	4 -5
4.1.4 6.0 kW to 15.0 kW Servodrives	4 -6
4.2 Name and Description of Main Circuit Terminals	4 -7
4.3 Applicable Receptacles	4 -7
4.3.1 1CN Connector for I/O Signals	4 -7
4.3.2 2CN Connector for Encoder	4 -7
4.3.3 4CN Connector for MECHATROLINK Communication	4 -8
4.4 Connecting an Incremental Encoder	4 -9
4.4.1 Typical Example	4 -9
4.4.2 1CN I/O Connector Terminals	4 -10
4.5 Connecting an Absolute Encoder	4 -14
4.5.1 Typical Example	4 -14
4.5.2 1CN I/O Connector Terminals	4 -15
4.6 Output Circuits	4 -18
4.7 Connector Terminal Block Converter Unit for 1CN	4 -19
4.7.1 Application	4 -19
4.7.2 Connection Specifications	4 -20
4.7.3 Cable Specifications Accessory (for Connector Terminal Block Converter Unit)	4 -21

4.8	2CN Encoder Connector Terminals	4 -22
4.8.1	2CN Terminal Layout	4 -22
4.8.2	Applicable Cables	4 -23
4.8.3	2CN Connection Method	4 -24
4.9	4CN Connectors for MECHATROLINK	
	Communications	4 -26
4.9.1	4CN Terminal Layout	4 -26
4.9.2	4CN Connection Method	4 -26

4.1 Internal Connection Diagram

4.1.1 0.5 kW to 1.5 kW Servodrives

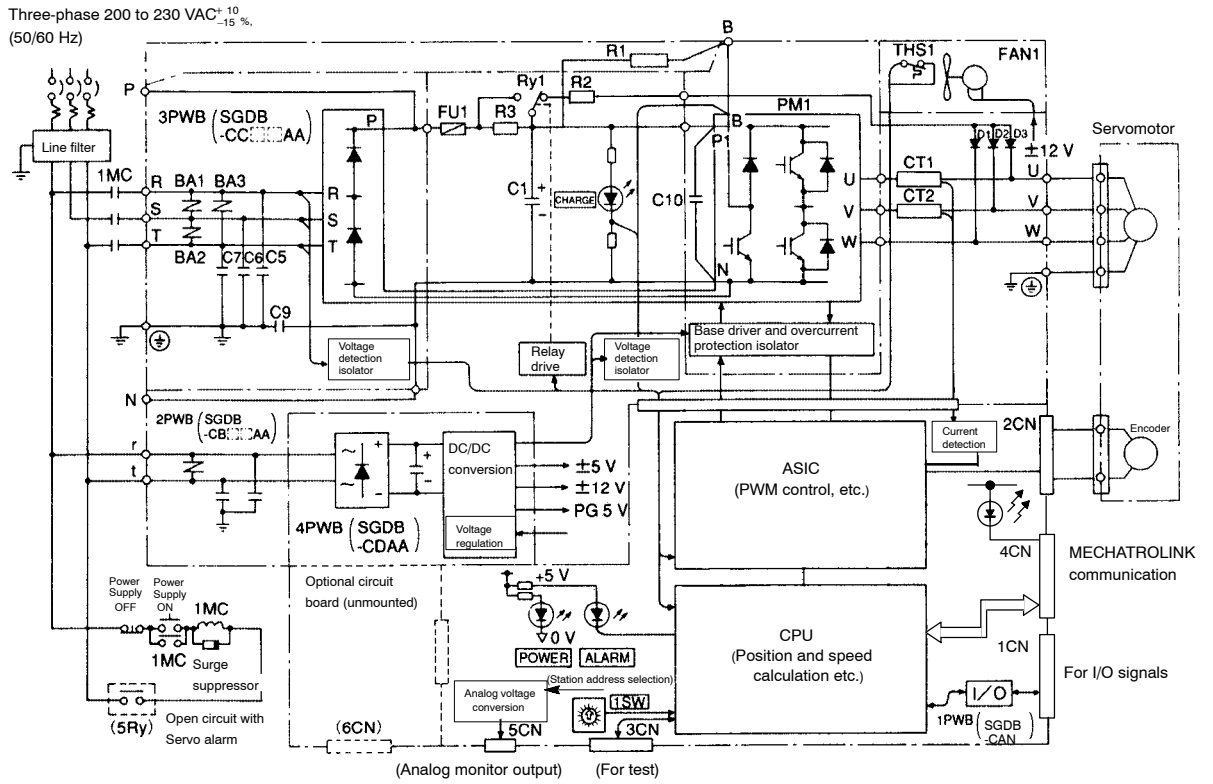

4.1.2 2.0 kW to 3.0 kW Servodrives

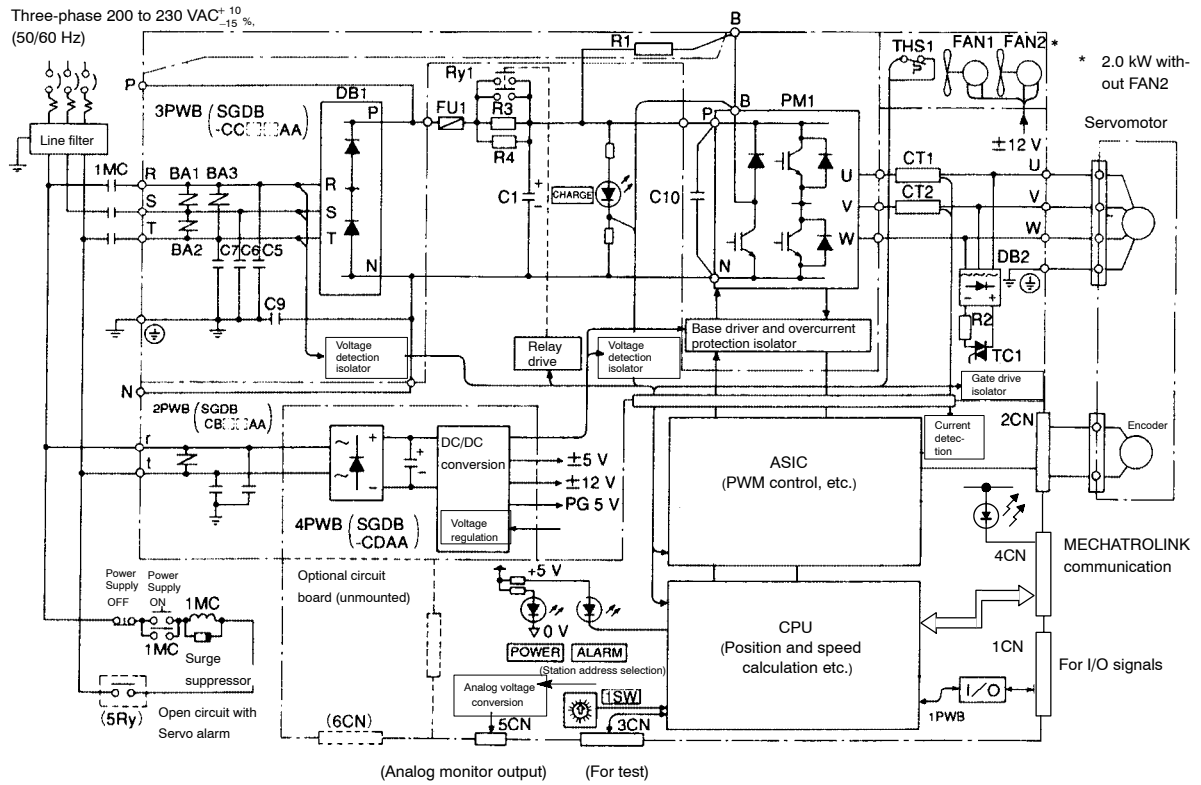

4

4.1.3 5.0 kW Servodrive

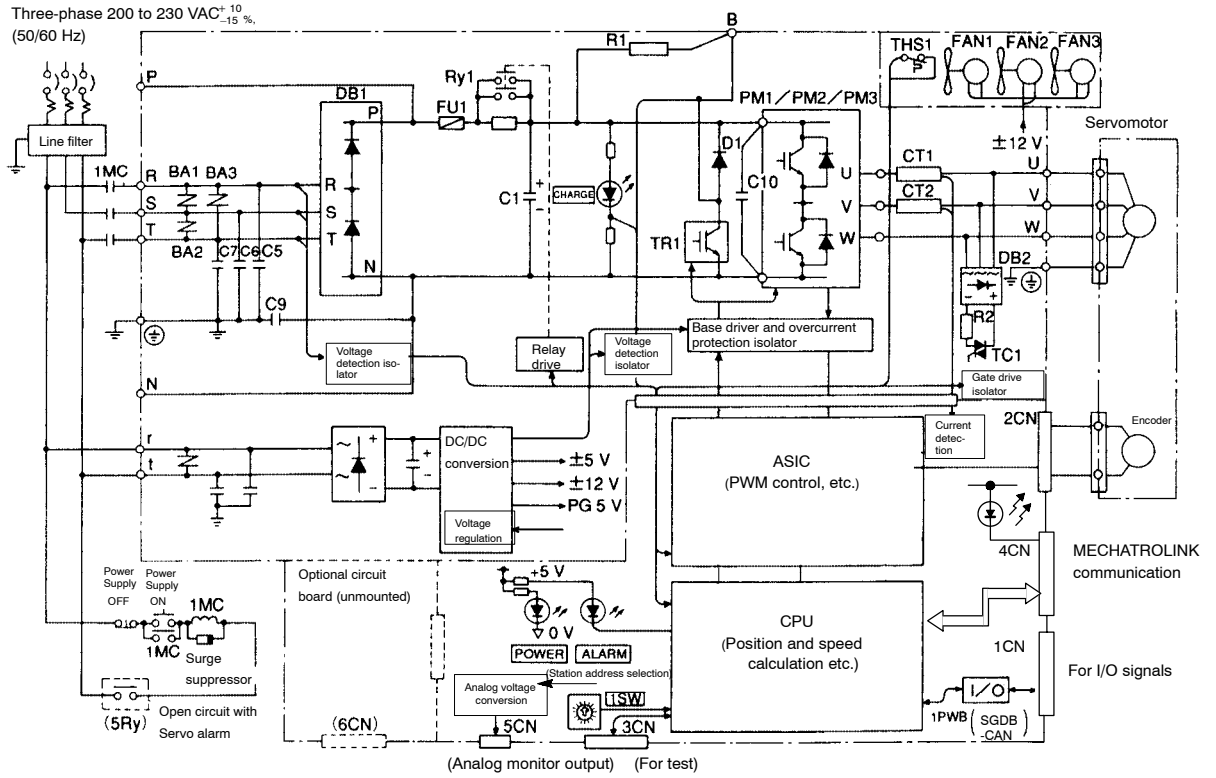

4.1.4 6.0 kW to 15.0 kW Servodrives

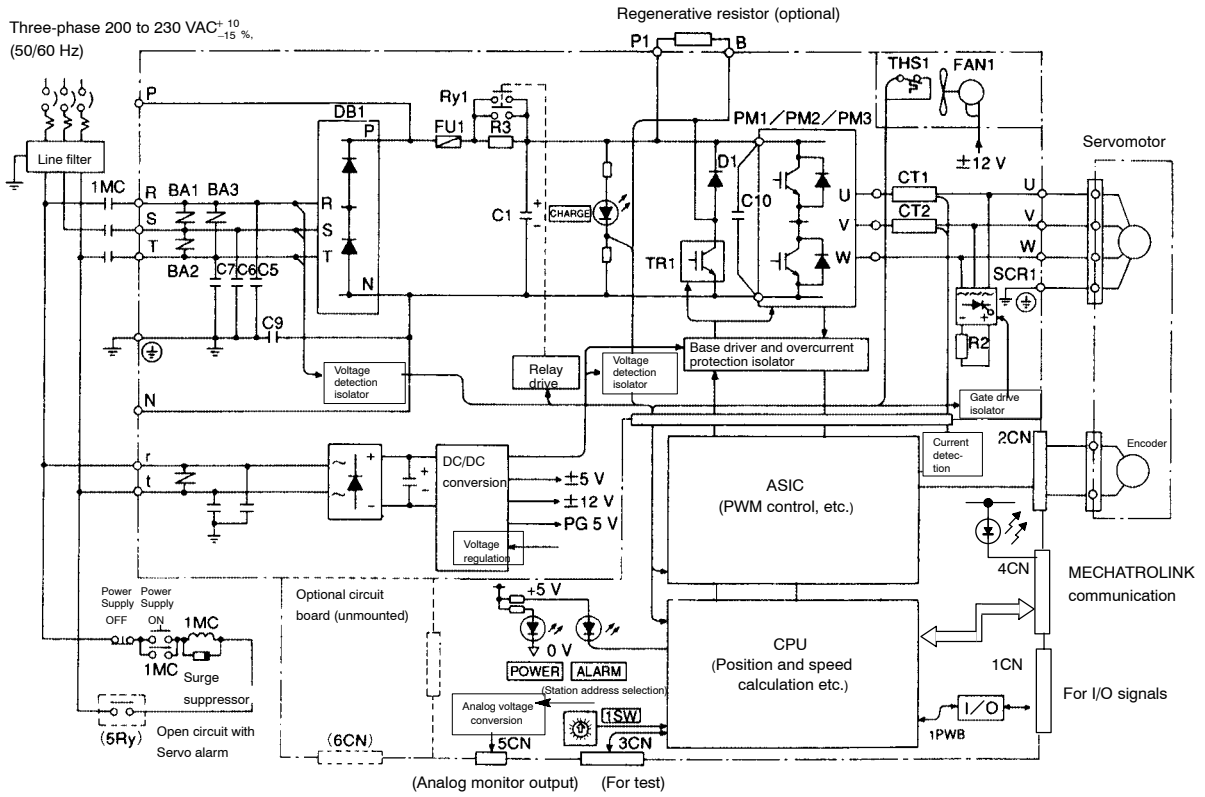

4

4.2 Name and Description of Main Circuit Terminals

Table 4.1 Name and Description of Main Circuit Terminals

Terminal Signal	Name	Description
R, S, T	Main circuit power supply input terminal	Three-phase 200 to 230 VAC +10 -15 %, 50/60 Hz
U, V, W	Motor terminal	Connects to the Servomotor.
r, t	Control power supply input terminal	Single-phase 200 to 230 VAC +10 -15 %, 50/60 Hz
Ⓧ2	Ground terminal	Connects to ground (for grounding the power supply and Servomotor).
P, B	Regenerative resistor unit terminal	SERVOPACK with 5 kW or less capacity (external connection is usually not needed.)
P1, B	Regenerative resistor unit terminal	SERVOPACKS with 6 kW or higher capacity
N	Main circuit negative terminal	External connection is usually not needed.

Note SERVOPACKS with 5 kW or less capacity do not have a P1 terminal.

4.3 Applicable Receptacles

4.3.1 1CN Connector for I/O Signals

Table 4.2 Specifications for Applicable SERVOPACK I/O Signal Receptacles

Specifications for SERVOPACK Connector	Applicable Receptacle Model		
	Solder	Case	Manufacturer
10226-52A2JL (Product of SUMITOMO 3M Co., Ltd.), 26 pin right angle	10126-3000VE	10326-52A0-008	SUMITOMO 3M Co., Ltd.

4.3.2 2CN Connector for Encoder

Table 4.3 Applicable Receptacle and Cable Specifications

Specifications for SERVOPACK Connector	Applicable Receptacle Model			Cable Specifications (see note)
	Solder	Case	Manufacturer	
10220-52A2JL (Product of SUMITOMO 3M Co.,Ltd.), 20 pin right angle	10120-3000VE	10320-52A0-008	SUMITOMO 3M Co., Ltd.	See 9.3 "Cables".

Note This cable is available from Yaskawa. Refer to 9.3 "Cables" for more details on cables.

4.3.3 4CN Connector for MECHATROLINK Communication

Table 4.4 Applicable Receptacle

Specifications for SERVOPACK Connector	Applicable Receptacle Model		
	Solder	Case	Manufacturer
MR-8RMD2 (Product of Honda Tsushin Industry Co., Ltd.), 8-pin right angle	MR-8F	MR-8L	Honda Tsushin Industry Co., Ltd.

4.4 Connecting an Incremental Encoder

4.4.1 Typical Example

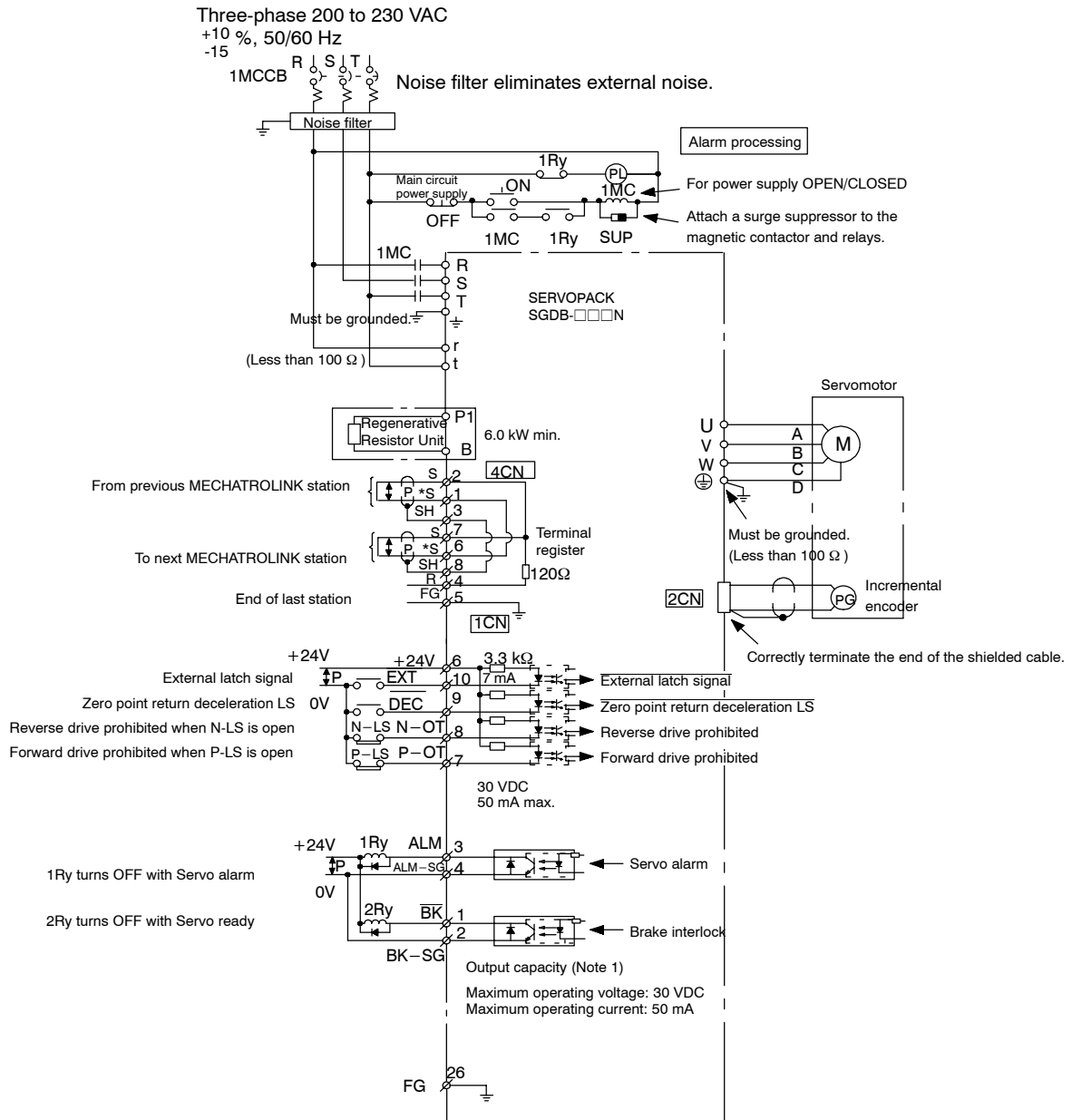

Note 1. Maximum capacity of each output circuit is 30 VDC and 50 mA.

2. Signal output line $\overline{\text{P}}$ represents twisted-pair wires.
3. The 24 VDC power supply (I/O power supply) must be supplied by the user.
4. The power supply must be ON while the servo alarm (1Ry) remains OFF till the communication connection (CONNECT command) is completed after the control power is turned ON.
5. SERVOPACK model SGDB-60 to -1E require a regenerative resistor (externally mounted option).

Figure 4.1 Example: SGDB-□□□N SERVOPACK Connection to Motor and Peripheral Device

4.4.2 1CN I/O Connector Terminals

■ Terminal Layout

Table 4.5 1CN Terminal Layout

2		4		6		8		10		12	
SG-BK		SG-ALM		+24 V IN		N-OT		EXT		-	
Signal ground for brake out		Signal ground for servo alarm		I/O power supply input		Reverse drive prohibited input		External latch signal input		-	
1		3		5		7		9		11	
/BK		ALM		-		P-OT		DEC		-	
Brake interlock signal output		Servo alarm output		-		Forward drive prohibited input		Zero point return deceleration LS input		-	
15		17		19		21		23		25	
-		-		-		-		-		-	
-		-		-		-		-		-	
14		16		18		20		22		24	
-		-		-		-		-		-	
-		-		-		-		-		-	
										26	
										FG	
										Frame ground	

Note 1. Do not connect any terminals marked with “-”.

2. Do not use vacant pins for relay or other purposes.

I/O Signal Connections and External Signal Processing

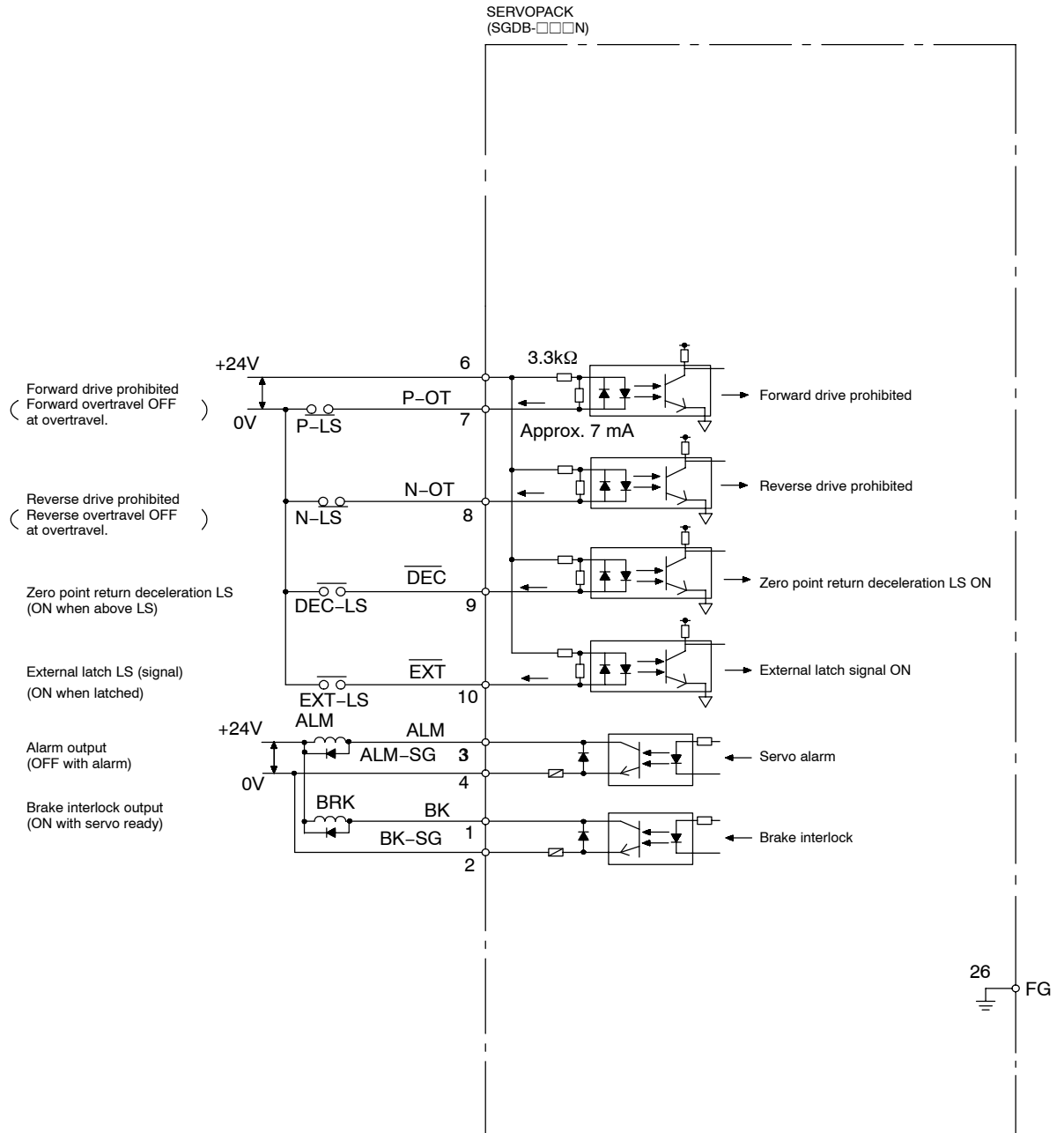

Note 1. The capacity of each output circuit is below 50 mA and 30 VDC.

2. The 24 VDC power (I/O power) supply must be supplied by the user.

Figure 4.2 1CN I/O Signal Connection and External Signal Processing

■ Input Signals and Their Application

Table 4.6 Input Signals

Signal Name	1CN Pin No.	Description	
N-OT P-OT	8 7	Reverse drive prohibited (Reverse overtravel) Forward drive prohibited (Forward overtravel)	Connect to the appropriate forward or reverse limit switch signal for linear or other types of drive. The signals are CLOSED during normal operation and are OPEN when the limit switch is operated. These functions can be canceled with user constant (Cn-0001 bits 2 and 3). Always $\overline{\text{N-OT}}$ or Always $\overline{\text{P-OT}}$ can also be set.
+24V IN	6	24 V	This is the power supply input for pins 7, 8, 9, and 10 of 1CN (I/O). The user must provide the 24 VDC (50 mA min.) power supply. The 12 V power supply can also be used.
$\overline{\text{DEC}}$	9	Zero point return deceleration LS	This signal is the deceleration LS input when the motor returns to the zero point. The signal is CLOSED on the LS. The polarity can be reserved with a user constant (Cn-0014, bit 12). If it is reserved, the signal will be OPEN on the LS.
EXT	10	External latch signal	This signal is the latch signal input for external signal. External signal will be latched when this signal is CLOSED.

4

■ Input Circuits

There are four types of input signals: Forward/reverse drive (overtravel) prohibited, zero point return deceleration LS, and external latch signal. They comprise the input circuits that use the 24 V power supply (see *Figure 4.3*). The 12 V power supply can be used instead, but the power supply is represented as “24 V” in the following descriptions. (The 12 V power supply provides only half the current of the 24 V power supply.) See *Figure 4.1* for an example of connections.

The user must provide the 24 V power supply: 24 VDC \pm 1 V, 50 mA min. (about 7 mA per circuit).

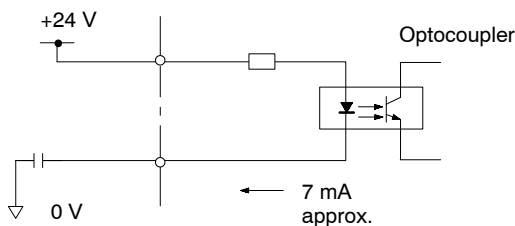

Figure 4.3 Input Circuit Configuration

P-OT and N-OT: Forward and Reverse Drive Prohibited

These inputs are used to stop the motor from forward running (counterclockwise viewed from the load coupling side) or reverse running. If drive prohibited is not used, connect 1CN pins 7 and 8 to the external 24 V power supply, or invalidate function by setting user constant Cn-0001 bit 2, 3.

When overtravel is operated, the speed is set to zero in the internal circuit for emergency stop. When the motor stops, set the clamp to zero. (The motor can also be stopped using user constant Cn-0001, bits 8 and 9.)

Zero Point Return Deceleration LS ($\overline{\text{DEC}}$)

The motor decelerates from the zero point return feed speed to zero point return approach speed 1 (Cn-0022) when the signal level changes from high to low during the zero point return operation. When this signal level goes from low to high, the motor moves from the first phase C pulse position to the position set by Cn-0028 (final travel distance) at zero point return approach speed 2 (Cn-0023). Then, the motor stops. Refer to the *MECHATROLINK Servo Command Manual* for details.

The deceleration LS requires that the low (closed) interval be at least 4 ms. If the interval is too short, reduce the feed speed.

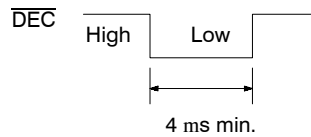

External Latch Signal ($\overline{\text{EXT}}$)

The external latch signal is used as a latch input signal for latch command or external positioning command. Refer to the *MECHATROLINK Servo Command Manual* for details.

Latching occurs at the falling edge when the signal level changes from high to low. Make sure that the low signal level (closed) interval is at least 500 μs .

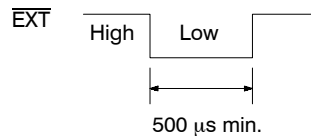

■ Output Signals and Their Application

Table 4.7 Output Signals

Signal Name	1CN pin No.	Description	
ALM	3 (4)	Servo Alarm	Turns OFF when an error is detected. Stays OFF until communication connection completes (CONNECT command) when the power is ON. See 5.4.2 "Error Detection Function" for further details.
$\overline{\text{BK}}$	1 (2)	Brake Interlock Output	Outputs the timing signal for the holding brake signal.

4.5 Connecting an Absolute Encoder

4.5.1 Typical Example

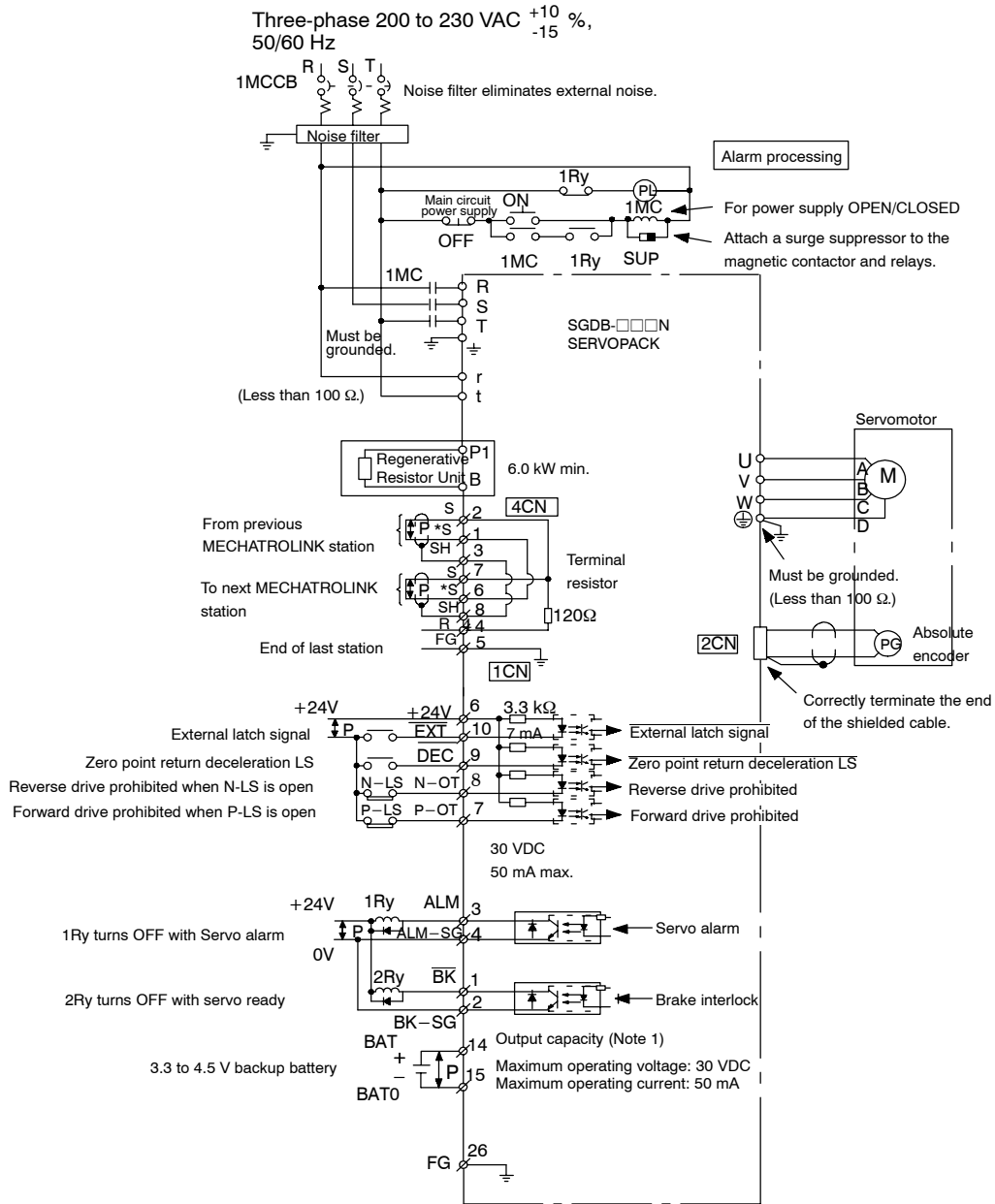

Note 1. Maximum capacity of each output circuit is 50 mA and 30 VDC.

2. Signal output line \overline{P} represents twisted-pair wires.
3. The 24 VDC power (I/O power) supply must be supplied by the user.
4. The power supply must be ON while the servo alarm (1Ry) remains OFF till the communication connection (CONNECT command) is completed after the control power is turned ON.
5. SERVOPACK model SGDB-60 to -1E require a regenerative resistor (externally mounted option).

Figure 4.4 Example: SGDB-□□□N SERVOPACK Connection to Motor and Peripheral Device

4.5.2 1CN I/O Connector Terminals

■ Terminal Layout

Table 4.8 1CN Terminal Layout

2	4	6	8	10	12	
BK-SG	ALM-SG	+24 V IN	N-OT	EXT	-	
Signal ground for brake out	Signal ground for servo alarm	I/O power supply input	Reverse drive prohibited input	External latch signal input	-	
1	3	5	7	9	11	13
BK	ALM	-	P-OT	DEC	-	-
Brake interlock signal output	Servo alarm output	-	Forward drive prohibited input	Zero point return deceleration LS input	-	-
15	17	19	21	23	25	
BAT 0	-	-	-	-	-	
Battery input (-)	-	-	-	-	-	
14	16	18	20	22	24	26
BAT	-	-	-	-	-	FG
Battery input (+)	-	-	-	-	-	Frame ground

Note 1. Do not connect any terminals marked with “-”.

2. Do not use vacant pins for relay or other purposes.

I/O Signal Connections and External Signal Processing

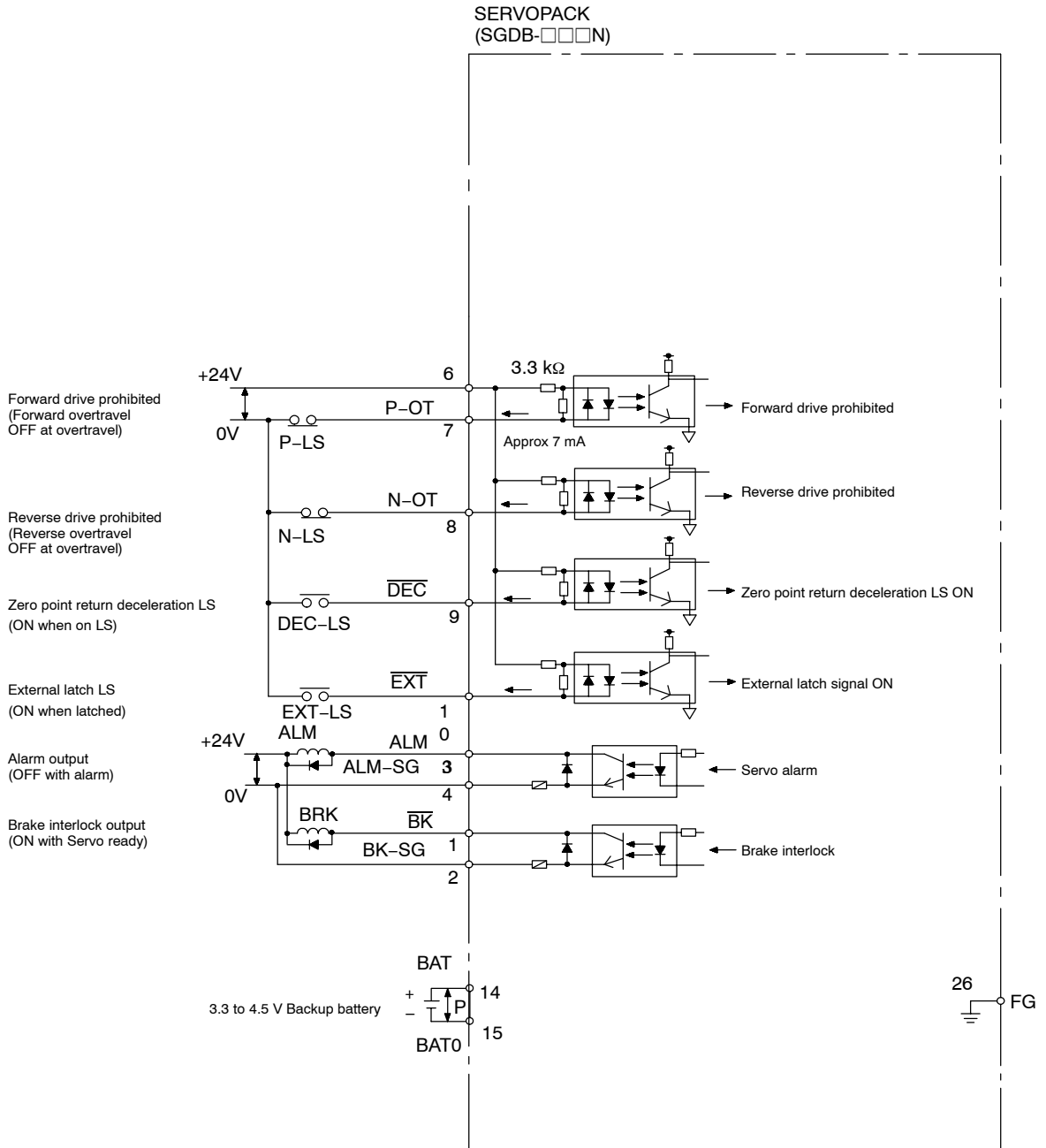

Note 1. Maximum capacity of each output circuit is 50 mA and 30 VDC.

2. The 24 VDC power (I/O power) supply must be supplied by the user.

3. Signal input wire $\overline{\text{P}}$ represents twisted-pair wires.

Figure 4.5 1CN I/O Signal Connection and External Signal Processing

■ Input Signals and Their Application

Table 4.9 Input Signals

Signal Name	1CN Pin No.	Description	
N-OT P-OT	8 7	Reverse drive prohibited (Reverse overtravel) Forward drive prohibited (Forward overtravel)	Connect to the appropriate forward or reverse limit switch signal for linear or other types of drive. The signals are CLOSED during normal operation and are OPEN when the limit switch is operated. This function can be canceled with user constant Cn-0001 bits 2 and 3. Always $\overline{\text{N-OT}}$ or Always $\overline{\text{P-OT}}$ can also be set.
+24V IN	6	24 V	This is the power supply input for pins 7, 8, 9, and 10 of 1CN (I/O). The user must provide the 24 VDC (50 mA min.) power supply. A 12 V power supply can also be used.
$\overline{\text{DEC}}$	9	Zero point return deceleration LS	This signal is the deceleration LS input when the motor returns to the zero point. The signal is CLOSED on the LS. The polarity can be reversed with user constant (CN-0014 bit 12). In this case, the signal will be OPEN on the LS.
$\overline{\text{EXT}}$	10	External latch input	This signal is the latch signal input for external signal. External signal will be latched when this signal is CLOSED.
BAT BAT0	14 15	Backup battery + input Backup battery - input	This terminal connects to the backup battery used when power to the absolute encoder is OFF. The voltage is 3.3 to 4.5 V. (The user must supply the battery.)

■ Input Circuits

The input signals are the same as those for the incremental encoder (See 4.4.2 “1CN I/O Connector Terminals”).

■ Output Signals and Their Application

Table 4.10 Output Signals

Signal Name	1CN Pin No.	Description	
ALM	3 (4)	Servo Alarm	Turns OFF when an error is detected. Stays OFF until communication connection completes (CONNECT command) when the control power is ON. See 5.4.2 “Error Detection Function” for further details.
$\overline{\text{BK}}$	1 (2)	Brake Interlock Output	Outputs the timing signal for the holding brake signal.

4.6 Output Circuits

There are two output signals: Brake interlock and servo alarm. They use non-contract transistor circuits. The voltage and current specifications for these signals are as follows:

Applied Voltage ($V_{max.}$) ≤ 30 V

Conduction Current (I_p) ≤ 50 mA

Output circuits require 24 V power supply by the user. We recommend the same 24 V power supply as that used for the input circuits.

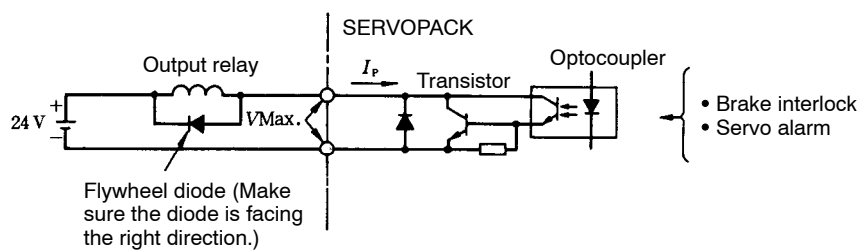
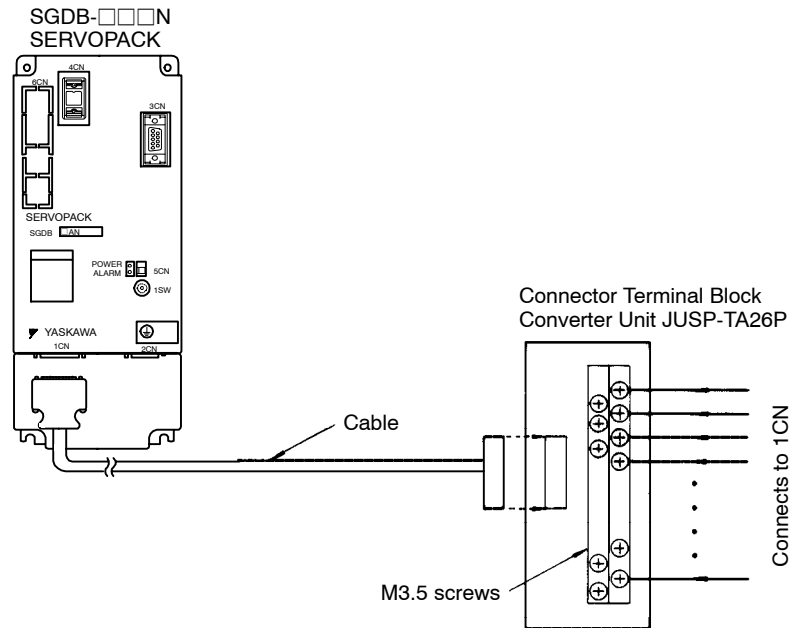

Figure 4.6 Output Circuits

4.7 Connector Terminal Block Converter Unit for 1CN

4.7.1 Application



Note There is no connector terminal block converter unit for the 2CN. We provide encoder cables for the 2CN connector. Obtain a cable of suitable length (See 9.3 “Cables”).

4.7.2 Connection Specifications

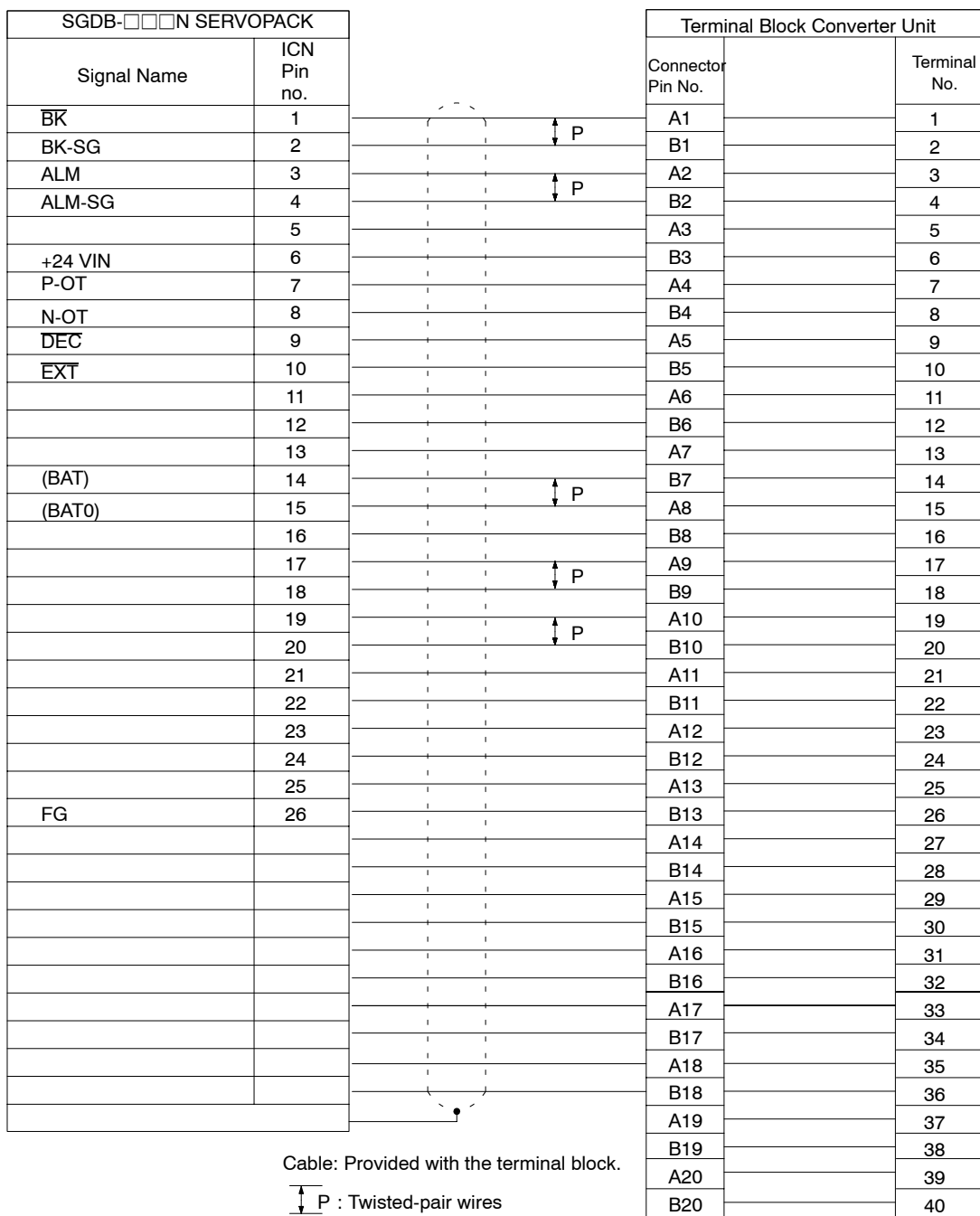

Note Do not use vacant pins.

4.7.3 Cable Specifications Accessory (for Connector Terminal Block Converter Unit)

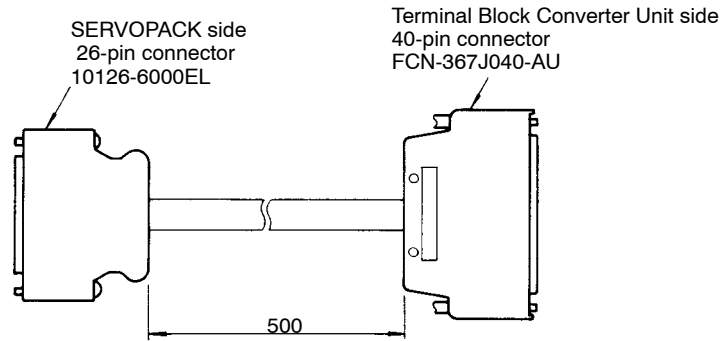

4.8 2CN Encoder Connector Terminals

4.8.1 2CN Terminal Layout

Table 4.11 Terminal Layout (2CN)

2	PG0V	PG power supply 0 V	1	PG0V	PG power supply 0 V	12	BAT+	Battery (+) (for absolute encoder only)	11		
4	PG5V	PG power supply +5 V	3	PG0V		14	PC	PG input phase C	13	BAT-	Battery (-) (for absolute encoder only)
6	PG5V		5	PG5V	PG power supply +5 V	16	PA	PG input phase A	15	*PC	PG input phase C
8	PS	PG input phase S (for absolute encoder only)	7	*DIR	Direction	18	PB	PG input phase B	17	*PA	PG input phase A
10			9	*PS	PG input phase S (for absolute encoder only)	20	FG	Frame ground	19	*PB	PG input phase B

* When connected to the PG 0 V terminal, the mode will change to reverse rotation. When not using the terminal, leave it open (normally open). If the user constant (Cn-0002 bit 2) is set to reverse rotation, the mode will be set to the reverse rotation mode. In the reverse rotation mode, the CW direction is regarded as the forward direction.

4.8.2 Applicable Cables

Yaskawa provides cables with the following specifications. Cables are not provided with the SERVOPACK or Servomotor. Order cables in the standard specifications (lengths) as required.

Table 4.12 Applicable Cables

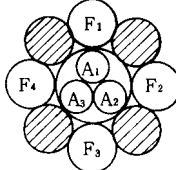
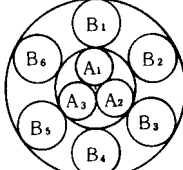
Cable Specifications	Incremental Encoder (Yaskawa Drg. #B9400064)	Absolute Encoder (Yaskawa Drg. #DP8409123)																																																
Basic Specifications	Compound KQVV-SW AWG22 × 3C, AWG26 × 4P	Compound KQVV-SW AWG22 × 3C, AWG26 × 6P																																																
Finished Dimension	φ7.5 mm (φ0.30 in) dia.	φ8.0 mm (φ0.31 in) dia.																																																
Internal Structure and Lead Colors (DP8409123 standard.)	 <table> <tr> <td>A₁</td> <td>Red</td> <td></td> </tr> <tr> <td>A₂</td> <td>Black</td> <td></td> </tr> <tr> <td>A₃</td> <td>Green yellow</td> <td></td> </tr> <tr> <td>F₁</td> <td>Blue/White blue</td> <td>Twisted pair</td> </tr> <tr> <td>F₂</td> <td>Yellow/White yellow</td> <td>Twisted pair</td> </tr> <tr> <td>F₃</td> <td>Green/White green</td> <td>Twisted pair</td> </tr> <tr> <td>F₄</td> <td>Orange/White orange</td> <td>Twisted pair</td> </tr> </table>	A ₁	Red		A ₂	Black		A ₃	Green yellow		F ₁	Blue/White blue	Twisted pair	F ₂	Yellow/White yellow	Twisted pair	F ₃	Green/White green	Twisted pair	F ₄	Orange/White orange	Twisted pair	 <table> <tr> <td>A₁</td> <td>Red</td> <td></td> </tr> <tr> <td>A₂</td> <td>Black</td> <td></td> </tr> <tr> <td>A₃</td> <td>Green yellow</td> <td></td> </tr> <tr> <td>B₁</td> <td>Blue/White blue</td> <td>Twisted pair</td> </tr> <tr> <td>B₂</td> <td>Yellow/White yellow</td> <td>Twisted pair</td> </tr> <tr> <td>B₃</td> <td>Green/White green</td> <td>Twisted pair</td> </tr> <tr> <td>B₄</td> <td>Orange/White orange</td> <td>Twisted pair</td> </tr> <tr> <td>B₅</td> <td>Purple/White purple</td> <td>Twisted pair</td> </tr> <tr> <td>B₆</td> <td>Gray/White gray</td> <td>Twisted pair</td> </tr> </table>	A ₁	Red		A ₂	Black		A ₃	Green yellow		B ₁	Blue/White blue	Twisted pair	B ₂	Yellow/White yellow	Twisted pair	B ₃	Green/White green	Twisted pair	B ₄	Orange/White orange	Twisted pair	B ₅	Purple/White purple	Twisted pair	B ₆	Gray/White gray	Twisted pair
A ₁	Red																																																	
A ₂	Black																																																	
A ₃	Green yellow																																																	
F ₁	Blue/White blue	Twisted pair																																																
F ₂	Yellow/White yellow	Twisted pair																																																
F ₃	Green/White green	Twisted pair																																																
F ₄	Orange/White orange	Twisted pair																																																
A ₁	Red																																																	
A ₂	Black																																																	
A ₃	Green yellow																																																	
B ₁	Blue/White blue	Twisted pair																																																
B ₂	Yellow/White yellow	Twisted pair																																																
B ₃	Green/White green	Twisted pair																																																
B ₄	Orange/White orange	Twisted pair																																																
B ₅	Purple/White purple	Twisted pair																																																
B ₆	Gray/White gray	Twisted pair																																																
Yaskawa Standard Specifications	Standard lengths: 3 m (9.9 ft), 5 m (16.4 ft), 10 m (32.8 ft), 15 m (49.2 ft), 20 m (65.6 ft) (see Note 2.)																																																	

Note 1. The maximum allowable wiring distance for applicable cables between the SERVOPACK and the Servomotor (PG) is 20 m (65.6 ft).

2. See 9.3 “Cables” for further details on cables.

4.8.3 2CN Connection Method

■ Incremental Encoder

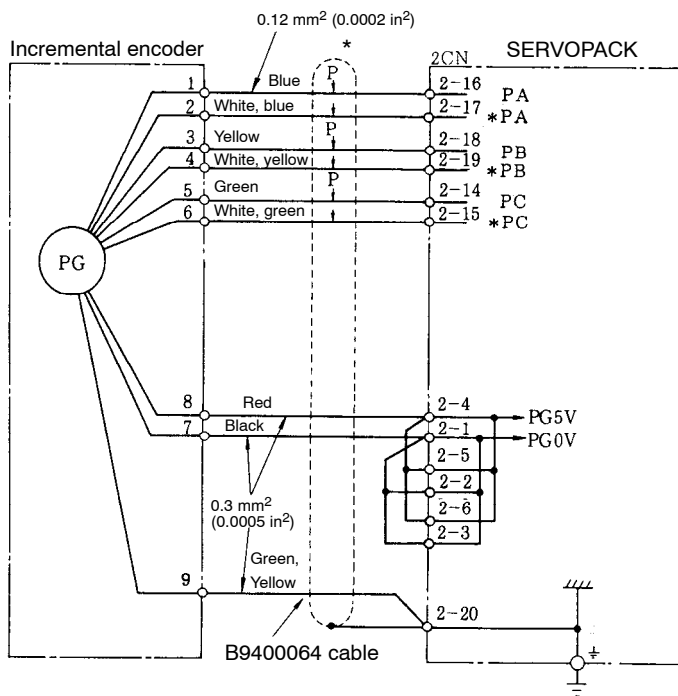

* represents twisted-pair wires.

Figure 4.7 Using a B9400064 Cable for an Incremental Encoder

4

■ Absolute Encoder

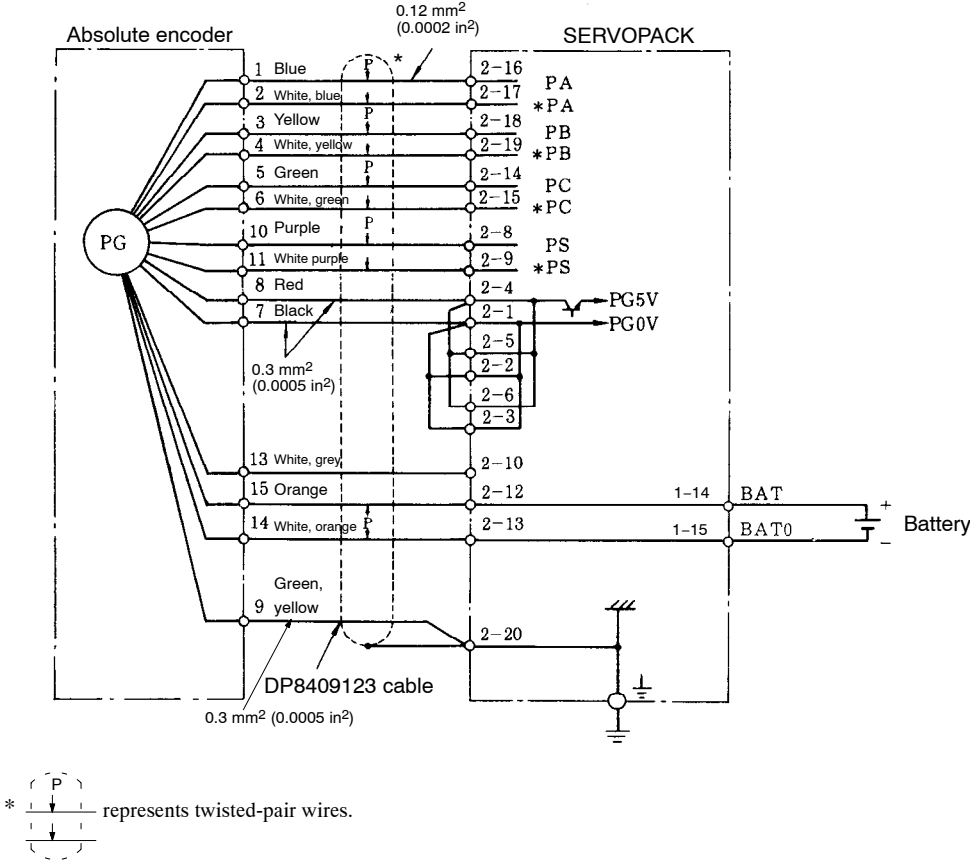

Figure 4.8 Using a DP8409123 Cable for an Absolute Encoder

4.9 4CN Connectors for MECHATROLINK Communications

4.9.1 4CN Terminal Layout

Table 4.13 4CN Terminal Layout

1	2	3
*S	S	SH
Serial data		Shield
4	5	
R	FG	
Termination resistor		Frame ground
6	7	8
*S	S	SH
Serial data		Shield

4.9.2 4CN Connection Method

■ Host Controller and SERVOPACK Connection

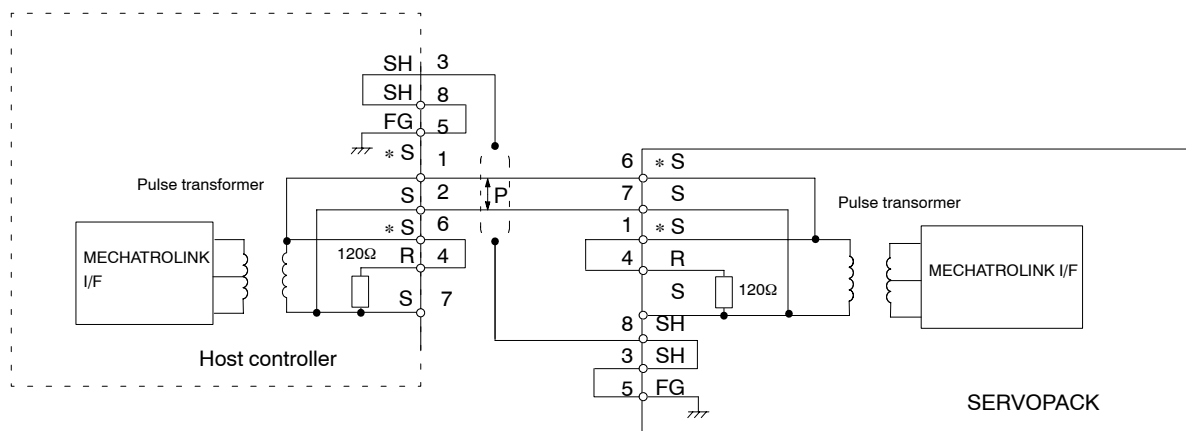

Note $\overline{\text{P}}$ represents twisted-pair wires and $\langle \rangle$ represents a shield.

■ Cables

Be sure to use the specified cables.

For more information on cables, refer to 9.3 Cables.

Multiple Axis Connections

Only last axis SERVOPACK on the cable. Short 4CN pins 1 and 4, and insert a termination resistor. Then, short 4CN pins 3 and 5, and ground the shield to the frame ground. Also, insert a termination resistor ($120\ \Omega$) and ground the shield to the frame ground at the host controller.

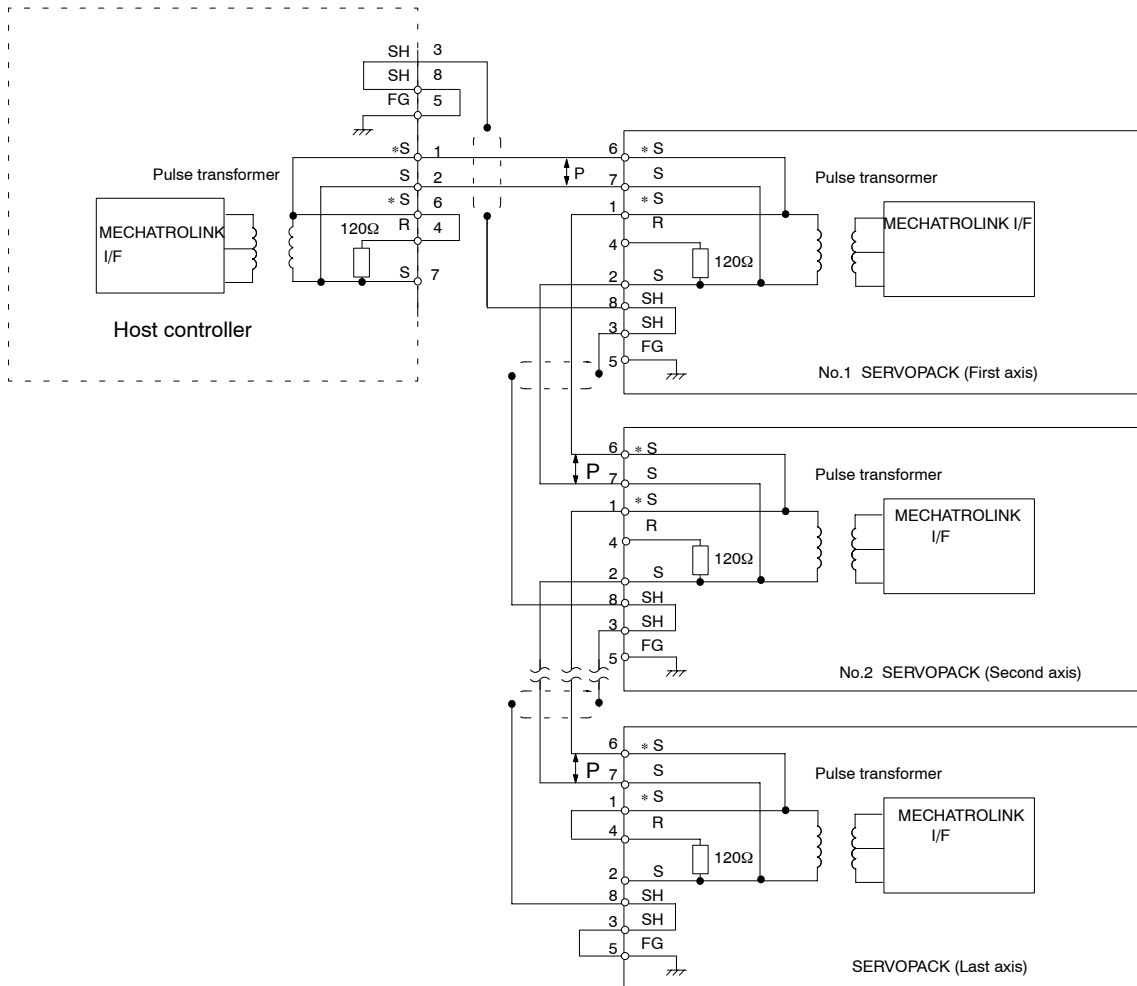

Note $\overline{\text{P}}$ represents twisted-pair wires and $\overline{\text{SH}}$ represents a shield.
Some host controller manuals describe different method for shield grounding. Follow the procedures outlined in the host controller manual for shield grounding.

Number of Stations

Up to 15 stations max. can be connected.

Cable Length

The total cable length must be 50 m or less.

(The total cable length between each station from the 1st to the last must be 50 m or less.)

Cable Length between Stations

The length of the cable between stations must be 0.3 m or more.

5

Application

This chapter describes how to use the Servodrives.

5.1	Turning Power ON/OFF	5 -3
5.2	Position Control	5 -4
5.2.1	Electronic Gear Function	5 -4
5.2.2	Feed-forward Control Function	5 -5
5.3	Setting Up a 12-bit Absolute Encoder	5 -6
5.3.1	Battery	5 -6
5.3.2	Absolute Encoder Setup Procedure	5 -6
5.4	Protection Functions	5 -8
5.4.1	Dynamic Brake Function	5 -8
5.4.2	Error Detection Function	5 -8
5.4.3	Servo Alarm Output (ALM, ALM-SG)	5 -9
5.4.4	Handling Protection Circuit Operation	5 -9
5.4.5	Servo Alarm Reset	5 -9
5.5	Indications	5 -9
5.6	Precautions	5 -10
5.6.1	Overhanging Load	5 -10
5.6.2	Load Inertia J_L	5 -10
5.6.3	Regenerative Resistor Unit	5 -10
5.6.4	High Voltage Lines	5 -12
5.7	Application Precautions	5 -13
5.7.1	Noise Control	5 -13
5.7.2	Power Supply Line Protection	5 -16

5.8 Appropriate Applications	5 -18
5.8.1 Holding Brake Interlock Signal	5 -18
5.9 Adjustments	5 -19
5.9.1 Servo System Adjustments	5 -19
5.9.2 User Constants	5 -20
5.9.3 Functions that Improve Response	5 -23
5.9.4 Guidelines for Setting the Load Inertia Ratio	5 -24

5.1 Turning Power ON/OFF

The figure below shows a typical example of the power ON/OFF sequence.

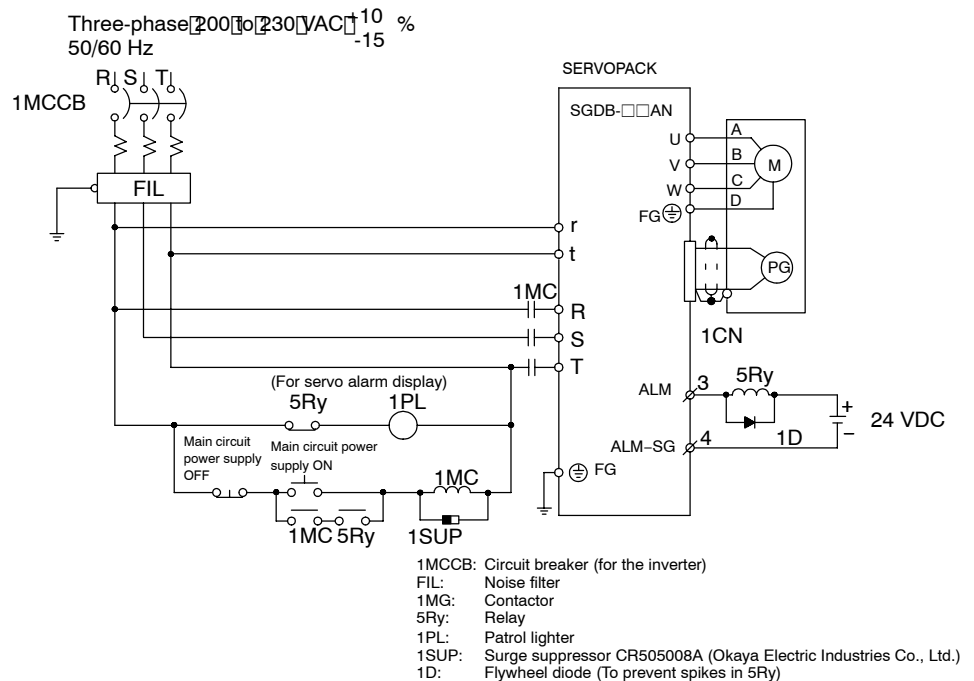

Figure 5.1 Example of Power ON/OFF Sequence

IMPORTANT

1. Construct a power ON sequence so the power is turned OFF if a servo alarm signal is output. See 5.4.4 “Handling Protective Circuit Operation” for more details on handling the alarm signal output.
2. During the power ON and OFF sequence shown in *Figure 5.1*, it takes up to approx. two seconds until the normal signal is valid once power is turned ON assuming that the CONNECT command has been received.
3. It takes up to approx. two seconds to initialize settings in the SERVOPACK when the control power is turned ON. The servo alarm signal will be output (ON) until the communication connection is completed for the CONNECT command.
4. The SERVOPACK has a capacitor in the power supply. A high charging current will thus flow for 0.6 seconds when the power is turned ON. Frequently turning the power ON and OFF will cause the main power devices (such as capacitors and fuses) to deteriorate and can result in unexpected problems. Start and stop the Servomotor by SV_ON/SV_OFF commands rather than turning the power supply ON and OFF.
5. After turning the power OFF, do not touch the power terminals for at least five minutes because high voltage may remain in the SERVOPACK. Residual voltage still remains in the SERVOPACK even after power is turned OFF. Make sure the charge lamp is unlit first before starting an inspection.

5.2 Position Control

5.2.1 Electronic Gear Function

The electronic gear function enables the distance the motor travels for one reference unit to be set to any value. More specifically, the value is set based on the number of encoder pulses, reference unit (minimum unit of position data for moving the load), and machine gear ratio. When the electronic gear ratio is 1/1, the motor will move one reference unit per pulse input.

■ Setting the Electronic Gear Ratio (B/A)

Determining the Reference Unit

The electronic gear ratio represents the number of encoder pulses per reference unit.

The reference unit is the minimum unit of position data for moving the load, e.g., 0.01 mm, 0.1°, or 0.01 inches.

Example: Reference Unit = 0.1 μm

If a move reference of 50000 reference units is input, the load moves 5 mm (50000 × 0.1 = 5000 μm = 5 mm).

Determine the reference unit based on factors like equipment specifications and positioning precision.

Determining the Load Travel Distance per Load Shaft Revolution in Reference Units

$$\text{Load travel distance per load shaft revolution (in reference units)} = \frac{\text{Load travel distance per load shaft revolution (in distance units)}}{\text{Reference unit}}$$

Table 5.1 shows an example of the load travel distance per load shaft revolution.

Table 5.1 Example of the Load Travel Distance per Load Shaft Revolution

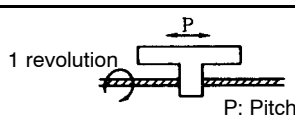
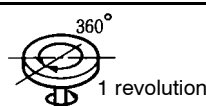
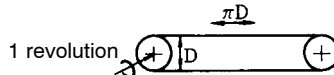
Load Travel Distance per Load Shaft Revolution	Example of the Load Structure	
P	Ball screw	
360°	Disc table	
πD	Belt and pulley	

Example: Load Travel Distance per Load Shaft Revolution= 12 mm (0.47 in), Reference Unit = 0.01 mm (0.0004 in)

Load travel distance per load shaft revolution = $12/0.01 = 1200$ (reference units)

Determining the Electronic Gear Ratio (B/A)

$B = [(Cn-0011) \times 4] \times (\text{motor shaft revolution speed})$

$A = [\text{Load travel distance per load shaft revolution (reference units)}] \times (\text{load shaft speed})$

Reduce the electronic gear ratio (B/A) to the lowest terms so that both A and B are less than 32768, and then set A and B in Cn-0025 and Cn-0024.

Motor Shaft and Load Shaft Revolution Speed

The motor shaft and load shaft speeds form the gear ratio for the mechanical system. If the mechanical system is structured so that load shaft makes “l” revolutions when the motor shaft makes “m” revolutions, the gear ratio for the motor shaft and the load shaft is m/l, as shown below.

Motor shaft speed: m (revolutions)

Load shaft speed: l (revolutions)

Fig. 5.2 shows a block diagram of the electronic gear function.

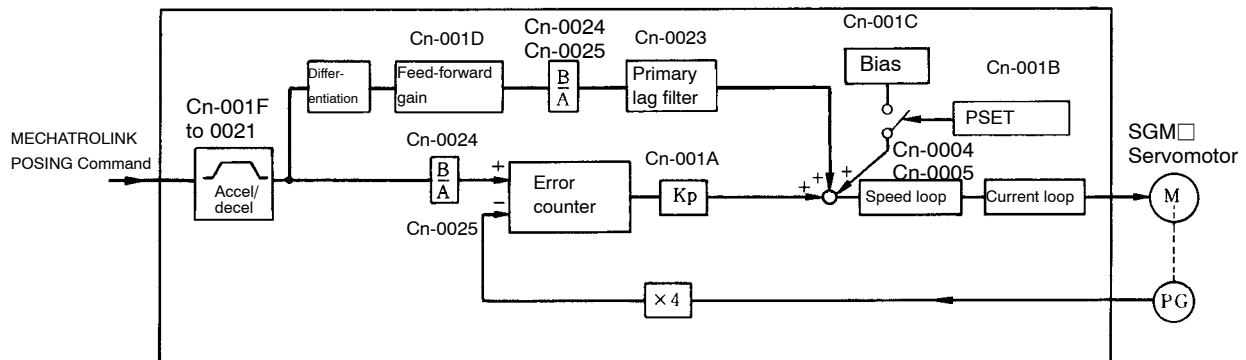

Figure 5.2 Block Diagram of the Electronic Gear Function

5.2.2 Feed-forward Control Function

The feed-forward control function performs differentiation of position and add it to speed reference in order to shorten positioning time. Set the amount of feed-forward control (0% to 100%) in Cn-001D, but do not set the level too high, because this may cause overshooting with small loads.

A primary lag filter can be added for the feed-forward reference. If it is added, set the time constant for the primary lag filter in user constant Cn-0027.

5.3 Setting Up a 12-bit Absolute Encoder

5.3.1 Battery

An absolute encoder requires a battery in order to save position data in the event of a power interruption.

- We recommend the following battery.
One lithium battery: ER6VC 3.6 V battery made by Toshiba Battery Co., Ltd.
- Make sure the battery is installed securely so that environmental changes or changes over time will not cause a loss of contact.
- The battery voltage is not monitored inside the SERVOPACK (with 12 bit absolute encoder). Provide a battery voltage monitor circuit as necessary.
Minimum voltage: 3.3 V
- See *12.1.3 Replacing the Battery* for more details on battery replacement.

5.3.2 Absolute Encoder Setup Procedure

The encoder needs to be set up to clear the cumulative rotation number to zero to set up the motor, or when the absolute encoder has been left disconnected from a battery for more than two days.

■ Setup Procedure

Follow the setup procedure described below. Failure to follow the procedure exactly as written may result in problems.

1. Turning ON SERVOPACK Power

- Wire the SERVOPACK, motor, and encoder together correctly.
Connect the battery and turn ON the SERVOPACK.
- Send the SENS_ON command by MECHATROLINK communication (encoder power ON). Then leave the SERVOPACK turned ON for at least thirty minutes to sufficiently charge the backup capacitor.

2. Resetting Data

- Turn OFF the SERVOPACK, and disconnect the encoder connector.
- Short encoder terminals 13 and 14 together for 1 to 2 seconds. (SGM and SGMP Servomotors with 12-bit absolute encoder)

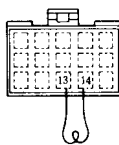

- Short the R and S encoder connector terminals for at least two minutes. (SGMG, SGMD and SGMS Servomotors with 15-bit absolute encoder)

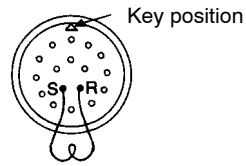

Verify that the 15-bit absolute encoder has been reset correctly as follows.

- The voltage between the terminal R and S is 0.4 V or less. (To measure the voltage between the terminals, use a tester with input impedance 1 M Ω or more.)
3. Restore the normal wiring.
 4. Turn ON power.
The setup is complete if there are no errors after the SERVOPACK is turned ON and send the SENS_ON command. If alarm code “00” is transferred by MECHATROLINK communication from the SERVOPACK, then repeat the procedure starting from the beginning.

5.4 Protection Functions

The SERVOPACK is equipped with various functions to protect the driver and motor from damage.

5.4.1 Dynamic Brake Function

The SERVOPACK is equipped with a dynamic brake for emergency stops. The brake is operated for any of the following conditions.

- When an alarm occurs (error detection)
- When the servo receives SV_OFF command
- When power is turned OFF

5.4.2 Error Detection Function

Table 5.2 shows the error detection function in the SERVOPACK. Alarm details can be checked by MECHATROLINK communication and SVALM output.

Table 5.2 Error Detection Function

Alarm Code	SVALM Output	Error Detection Function	Description
0□	OFF	User constant error Absolute data error	An absolute or parameter (user constant) error.
1□	OFF	Overcurrent Ground detection	<ul style="list-style-type: none"> • Overcurrent flowed through the main circuit. • Overcurrent flows to the main circuits and Servomotor power lines are grounded.
30	OFF	Regenerative error	A regenerative resistor circuit malfunctioned.
4□	OFF	Overvoltage Undervoltage detection	DC voltage is abnormal in the main circuit.
51	OFF	Overspeed detection	Motor speed exceeded the maximum speed.
7□	OFF	Overload Heat sink overheating detection	<ul style="list-style-type: none"> • The load torque for the motor and SERVOPACK was exceeded. • SERVOPACK heat sink overheated.
B□	OFF	Hardware error	The hardware circuit is abnormal.
C□	OFF	Phase error detection Overrun detection Broken PG signal line	<ul style="list-style-type: none"> • An overrun was caused by the motor or the PG wiring incorrect. • Noise in encoder wiring
8□	OFF	Encoder alarm	Absolute encoder alarm.
9□	ON	Warning	A user constant or command error.
D0	OFF	Position error overflow	The number of pulses accumulated in the error counter exceeded the preset value.
E□	OFF	Communication error	A synchronization error or communications error.
F□	OFF	Power supply line not connected Instantaneous power loss error	<ul style="list-style-type: none"> • One phase of the main circuit power supply not connected. • Power loss occurred during operation.
99	ON	No alarm	–

ON: Output transistor is ON

OFF: Output transistor is OFF

5.4.3 Servo Alarm Output (ALM, ALM-SG)

The power drive circuit in the SERVOPACK will turn OFF and the alarm status will be displayed if any error detection function shown in Table 5.2 operates. Details of the alarm will be sent by a MECHATROLINK response message, the red indicator on the SERVOPACK will light, and the alarm output (ALM, ALM-SG) will turn OFF. See *Table 5.2* for more details on alarm codes.

5.4.4 Handling Protection Circuit Operation

An alarm signal output indicates some kind of error. Determine the cause, take appropriate action, and then resume operation.

■ Error Troubleshooting

Check the error data for past occurrences using the error traceback mode of the MECHATROLINK communications, and implement the remedy listed in *Table 12.6*, on page 12 -6.

5.4.5 Servo Alarm Reset

To reset the SERVOPACK when a servo alarm occurs, send the MECHATROLINK ALM_CLR command, or turn the power OFF and then back ON.

5.5 Indications

The following indications are made on the front panel of the SERVOPACK.

- Power ON: Green LED lights.
- Alarm occurred: Red LED lights.
- During MECHATROLINK communication: Green LED lights.

5.6 Precautions

5.6.1 Overhanging Load

Do not allow the motor to be continuously rotated by the load while the regenerative brake is being applied.

Example: Tension control drive

Do not use the motor for lowering objects without a counterweight.

Rated specifications for the regenerative braking capacity of the SERVOPACK is only for brief periods while the motor is stopped. Contact your Yaskawa representative about applications with negative load.

5.6.2 Load Inertia J_L

The allowable load inertia J_L calculated for the motor shaft is limited to less than five times of the motor inertia (J_M). If the load inertia exceeds this value, an overvoltage alarm may occur during deceleration. If this occurs, take one of the following actions. Contact our sales representative for further details.

- Reduce the torque limit.
- Reduce the deceleration rate.
- Reduce the maximum rotation speed.

5.6.3 Regenerative Resistor Unit

A regenerative resistor unit is used as an SGDB SERVOPACK peripheral device with 6.0 kW or higher capacity. Externally connect a Regenerative resistor unit to 6.0 kW or higher capacity SERVOPACKS because they do not have built-in regenerative resistors.

■ Connecting a Regenerative Resistor Unit

The connections of the regenerative resistor unit are shown below.

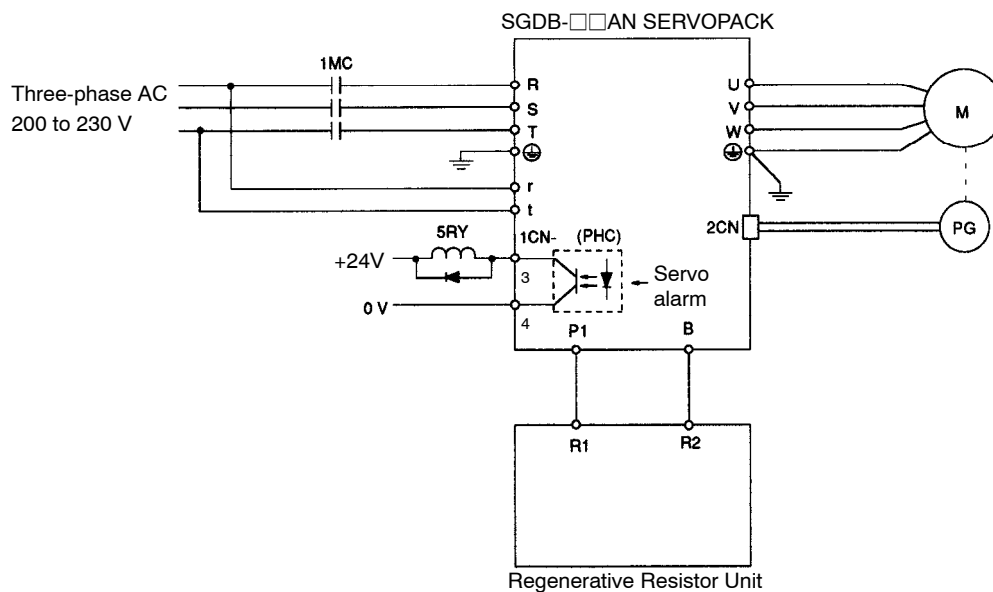

Figure 5.3 Regenerative Resistor Unit Connection Diagram

■ Applicable Regenerative Resistor Units

SERVOPACK Model	Applicable Regenerative Resistor Unit	Regenerative Resistor (Ω)
SGDB-60AN	JUSP-RA04	6.25
SGDB-75AN	JUSP-RA05	3.13
SGDB-1AAN		
SGDB-1EAN		

Regenerative Units will heat up to a high temperature depending on the Regeneration Operation Mode conditions of the servo system. It is therefore important to cool the unit, use heat-resistant, inflammable wire, and ensure that wiring does not come in contact with the unit.

The following are resistor specifications for the regenerative resistor units.

JUSP-RA04: 25 Ω (220 W) \times 4 connected in parallel

JUSP-RA05: 25 Ω (220 W) \times 8 connected in parallel

The temperature of the regenerative resistor reaches about 90°C when used at the rated resistor loss of 20%. Allowable Servomotor regeneration power (average) at this time is 180 W for the JUSP-RA04 and 350 W for the JUSP-RA05. Review servo system operating conditions and check whether the resistor is appropriate for the regenerative resistor unit because another resistor with a large rated allowable loss (W) must be selected if the regeneration power (average) exceeds these values in Regeneration Operation of the servo system.

Example of Allowable Servomotor Drive Duty Conditions

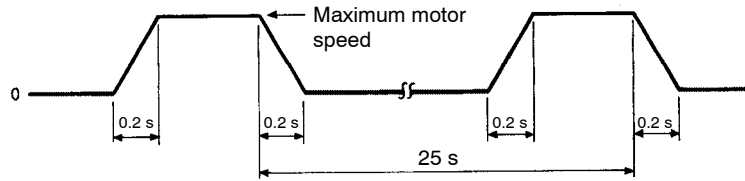

- Torque at Servomotor deceleration: Maximum torque
 - Load inertia: Five times the motor moment of inertia
- As long as there are no losses in the mechanical system.

5.6.4 High Voltage Lines

The power supply voltage of the SGDB SERVOPACK is three-phase 200 V class, and users must provide one of the following power transformers (three-phase) if they are using a three-phase 400 VAC class (400 V, 440 V) power supply.

Primary side voltage Secondary side voltage
 400 or 440 VAC → 200VAC

Select a power transformer capacity using the table below.

SERVOPACK Model	Power Supply Capacity per SGDB SERVOPACK (kVA)*
SGDB-05AN	1.1
SGDB-10AN	2.0
SGDB-15AN	2.5
SGDB-20AN	4.0
SGDB-30AN	5.0
SGDB-50AN	7.5
SGDB-60AN	12.5
SGDB-75AN	15.5
SGDB-1AAN	19.0
SGDB-1EAN	30.0

* Value with a rated load

5.7 Application Precautions

5.7.1 Noise Control

■ Example of Wiring for Noise Control

This SERVOPACK uses high-speed switching elements in the main circuit. It may be subjected to switching noise from these high-speed switching elements if wiring or grounding around the SERVOPACK is not appropriate. To prevent this, always wire and ground the SERVOPACK correctly.

The SERVOPACK also has a built-in microprocessor (CPU). Therefore install a noise filter to protect the microprocessor from external noise.

The diagram below shows an example of wiring for noise control.

■ Grounding

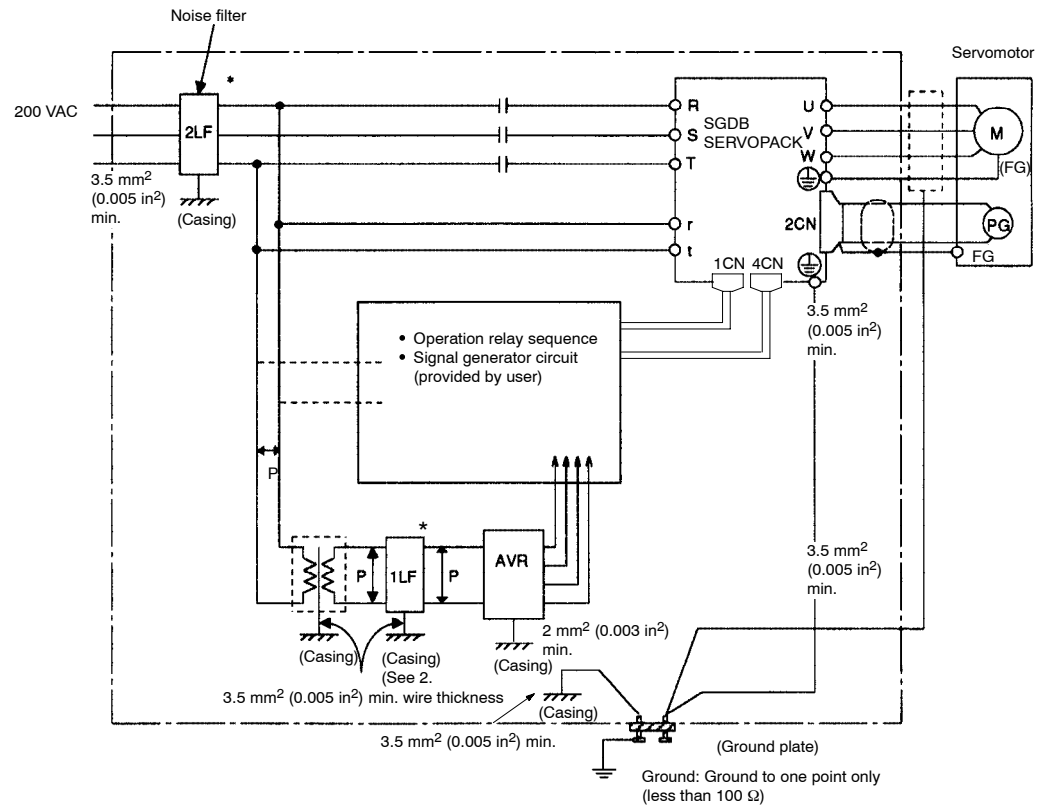



Figure 5.4 Grounding

* When using a noise filter, always observe the wiring instructions given in the next section.

Note 1. Use a wire (preferably a plain stitch copper wire) at least 3.5 mm² (0.005 in²) thick to ground the casing.

2. Use twisted-pair wires whenever possible for wires indicated by .

■ Correct Grounding

Motor Frame Grounding

If the Servomotor is grounded via the equipment frame, switching noise current ($C_f dv/dt$) will flow from the SERVOPACK power unit (PWM) through motor stray capacitance (C_f). Always connect the Servomotor ground terminal (FG) to the SERVOPACK ground terminal \oplus to prevent adverse effects from switching noise. Be sure to ground the ground terminal.

SERVOPACK SG 0 V

If the reference input line is subjected to noise, ground the SG 0 V line. If the main circuit wiring for the motor is in a metal conduit, ground the conduit as well as the junction box. Always ground to one point only.

■ Using a Noise Filter

Use an inhibit-type noise filter to block noise from the power supply line. *Table 5.3* lists recommended noise filters for each SERVOPACK. Also install a noise filter on the power supply line for peripheral equipment if needed.

IMPORTANT

Always observe the installation and wiring instructions shown in *Figs. 5.5* to *5.8*. Incorrect use of a noise filter reduces its benefits.

Table 5.3 Noise Filters

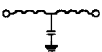
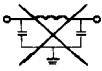
SERVOPACK Model		Noise Filter Connection	Recommended Noise Filter*		
			Model	Specifications	
0.5 kW	SGDB-05AN	(Correct) 	LF-310	Three-phase 200 VAC, 10 A	
1.0 kW	SGDB-10AN		LF-315	Three-phase 200 VAC, 15 A	
1.5 kW	SGDB-15AN		LF-320	Three-phase 200 VAC, 20 A	
2.0 kW	SGDB-20AN		LF-330	Three-phase 200 VAC, 30 A	
3.0 kW	SGDB-30AN		LF-340	Three-phase 200 VAC, 40 A	
5.0 kW	SGDB-50AN		LF-350	Three-phase 200 VAC, 50 A	
6.0 kW	SGDB-60AN		LF-360	Three-phase 200 VAC, 60 A	
7.5 kW	SGDB-75AN		LF-380K	Three-phase 200 VAC, 80 A	
11.0 kW	SGDB-1AAN		(Incorrect) 	FN258-100	Three-phase 200 VAC, 100 A
15.0 kW	SGDB-1EAN				

* These noise filters other than model FN258-100 are made by Tokin Corp. Tokin Corp. noise filters are available from Yaskawa. Contact your nearest Yaskawa sales representative for those noise filters. A noise filter type FN258-100 is made by SCHAFFNER.

- Separate input lines from output lines. Do not run input and output lines in the same duct or bundle them together.

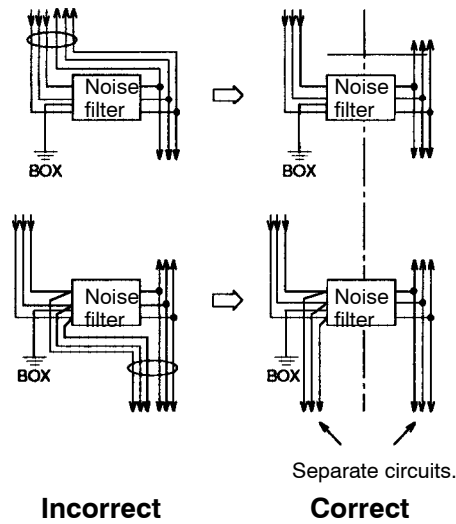

Figure 5.5

- Separate ground wires from noise filter output lines. Do not run ground wires, output lines, and other signal lines in the same duct or bundle them together.

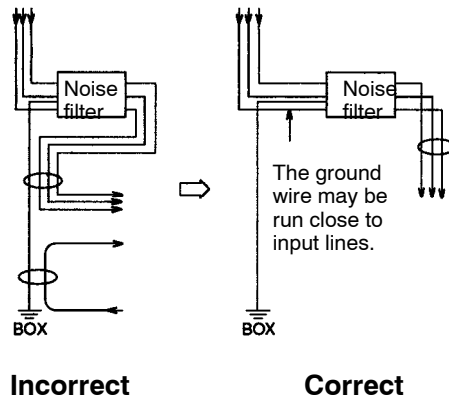

Figure 5.6

- Connect the noise filter ground wire directly to the junction box or the ground plate.

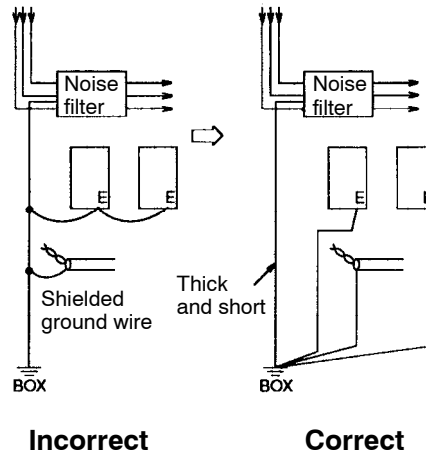

Figure 5.7

- When grounding a noise filter inside a unit, connect the noise filter ground wire and the ground wires for other devices inside the unit to the ground plate of the unit first, and then ground these wires.

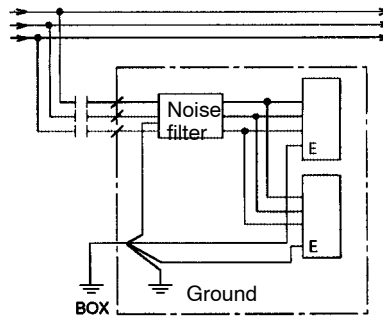

Figure 5.8

5.7.2 Power Supply Line Protection

The SERVOPACK is connected directly to a commercial power supply (200 V). To protect the power supply line from the ground fault or a contact, and to protect the system from fire, always use an appropriate molded-case circuit breaker (MCCB) or fuse for each SERVOPACK (see table 5.4). A fast-operating fuse cannot be used because the SERVOPACK power supply is a capacitor input type, and a fast-operating fuses may blow out when power is turned ON.

Molded-case circuit breaker

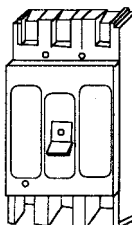

Table 5.4 MCCB or Fuse for the Power Capacity

SERVOPACK Model	Power Capacity per SERVO- PACK (kVA)*¹	Current Capacity per MCCB or Fuse (A)*²
SGDB-05AN	1.1	5
SGDB-10AN	2.0	8
SGDB-15AN	2.5	10
SGDB-20AN	4.0	12
SGDB-30AN	5.0	18
SGDB-50AN	7.5	28
SGDB-60AN	12.5	32
SGDB-75AN	15.0	41
SGDB-1AAN	19.0	60
SGDB-1EAN	30.0	80

* 1. Power capacity at the rated load

* 2. Operating characteristics (25°C): 2 s or more at 200%, 0.01 s or more at 700%

5.8 Appropriate Applications

5.8.1 Holding Brake Interlock Signal

This output signal can be output for interlocking motor circuit power status and motor rotation speed.

■ Setup Procedure

The brake signal is output from 1CN-1(2). Delay time t_B ($\times 10$ ms) from the brake turns ON until the Servomotor drives OFF can be set in user constant Cn-0012. The following shows the Servo ON signal and power supply timing.

Table 5.5 Servo ON Command and Main Circuit Power Supply Timing

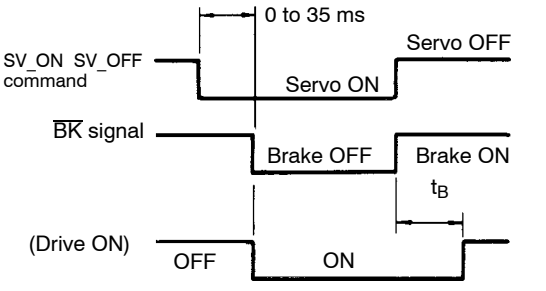
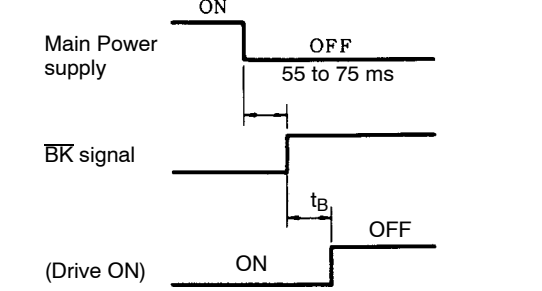
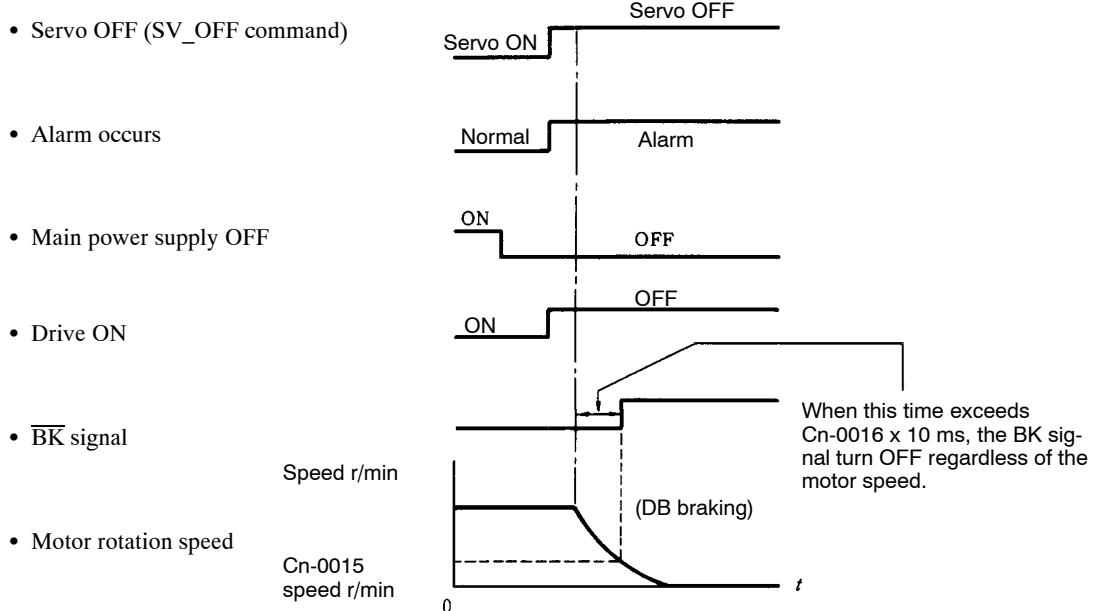
Motor Stopped	Servo ON Command Timing	Main Circuit Power Supply Timing
	 <p>t_B: Brake Time (set from 0 to 50 ms in Cn-0012)</p>	 <p>t_B: Brake Time (set from 0 to 50 ms in Cn-0012)</p>
Motor Running	<p>Timing with the Servo OFF, main power OFF, and an alarm</p> <ul style="list-style-type: none"> • Servo OFF (SV_OFF command) • Alarm occurs • Main power supply OFF • Drive ON • \overline{BK} signal • Motor rotation speed  <p>When this time exceeds Cn-0016 \times 10 ms, the BK signal turn OFF regardless of the motor speed.</p>	

Note 1. The setting value of Cn-0015 must be smaller than the number of motor rotation.

2. If the main circuit or the Servo is turned OFF due to an emergency stop or such during the motor runs, be sure to send the HOLD command before turning OFF the main circuit or Servo.

5

5.9 Adjustments

5.9.1 Servo System Adjustments

Once the load inertia constant (Cn-0003) has been specified, the following user constants (parameters) are used to adjust the servo system.

- Cn-0004: Speed Loop Gain
- Cn-0005: Speed Loop Integration Time Constant
- Cn-0017: Torque Reference Filter Time Constant
- Cn-001A: Position Loop Gain

A simple block diagram of the servo system is shown below.

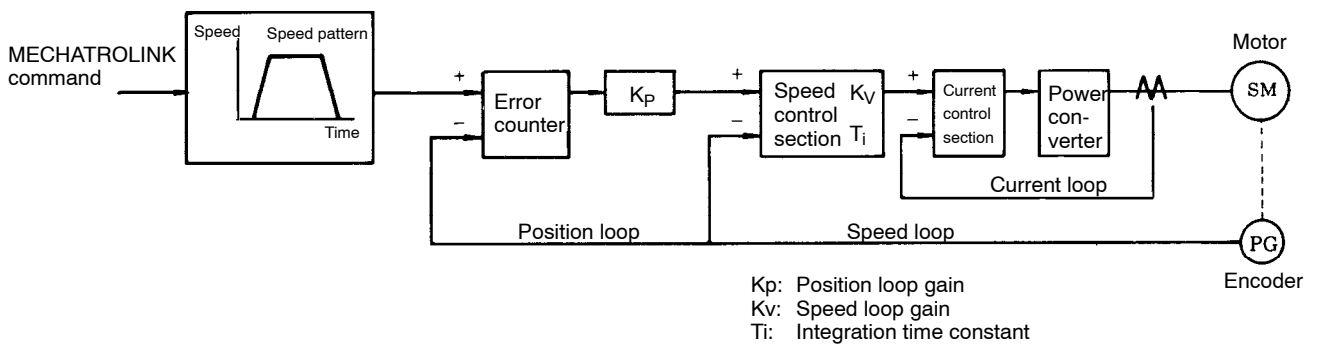

Figure 5.9 Servo System Block Diagram

■ Basic Rules for Gain Adjustment

The servo system is equipped with the following feedback systems.

- Position loop
- Speed loop
- Current loop

The inner loops require better response. Failure to follow this principle will result in poor response and vibration.

The current loop already provides adequate response and cannot be adjusted by the user. The user can adjust the position loop and speed loop gains. The speed loop integration time constant and torque reference filter time constant can also be adjusted by the user.

The responses of the position loop and speed loop must be kept in balance. Increasing the position loop gain alone to improve response will cause the speed reference in the SERVOPACK to vibrate, producing slow or inconsistent positioning times. If the position loop gain is increased, the speed loop gain must be similarly increased.

The mechanical system will start to vibrate at the upper limits for the position and speed loop gain. Do not exceed these limits. Generally position loop gain cannot be increased beyond the characteristic frequency of the mechanical system.

Example: Articulated Robots

Using harmonic gears produces a mechanism with extremely low rigidity.

Characteristic frequency of the mechanical system: 10 to 20 Hz

Allowable position loop gain: 10 to 20 (1/s)

Example: Chip Mounters, IC Bonders, Precision Machine Tools

Characteristic frequency: 70 Hz or more.

Position loop gain: 70 (1/s) or more.

The response of the servo system (Controller, Servodriver, Servomotor, encoder, etc.) is crucial to the response requirements, but a highly rigid system is also needed as well.

5.9.2 User Constants

■ Cn-0003: Load Inertia

This parameter specifies motor axis converted load inertia.

Specify a motor rotor inertia rate (motor inertia = 100%).

■ Cn-0004: Speed Loop Gain

The Speed Loop Gain sets the speed loop response. The response is improved by setting this user constant to the maximum value in a range that does not cause vibrations in the mechanical system.

■ Cn-0005: Speed Loop Integration Time Constant

The speed loop has an integration element that enables response to micro-inputs. Because this integration element can produce a delay in the servo system, positioning set time increases and response slows as the time constants increase.

The integration time constant must be increased, however, to prevent machine vibration if the load inertia is large or the mechanical system includes an element prone to vibration. The following equation can be used to calculate a guideline value.

$$T_i \geq 2.3 \times \frac{1}{2\pi \times K_v}$$

T_i : Integration time constant (s)

K_v : Speed loop gain (Hz)

■ Cn-0017, 0018: Torque Reference Filter Time Constant

When a ball screw is used, torsional resonance may occur that increases the pitch of the vibrating noise. This vibration can sometimes be overcome by increasing the torque reference filter time constant. The filter, however, will produce a delay in the servo system, just like the integration time constant, and its value should not be increased any more than necessary.

If the secondary torque reference filter time constant (Cn-0018) is set to 0, the torque reference filter will be switched to the primary filter.

If the vibration cannot be overcome by the torque reference filter time constant (Cn-0017), use the secondary torque reference filter time constant (Cn-0018) to switch the filter to the secondary filter and overcome the vibration.

■ Cn-001A: Position Loop Gain

The position loop gain determines the response of the servo system. The higher it is set, the higher the response and the less time it takes for positioning. As such, the equipment must have higher rigidity and a higher characteristic frequency.

The entire servo system is more susceptible to vibration if position loop gain alone is increased to improve response, and the speed reference output from the position loop will cause vibration. Always increase speed loop gain while checking the response.

Position loop gain K_p is calculated as shown below.

$$K_p = \frac{V_s}{\epsilon}$$

K_p (1/s): Position loop gain

V_s (PPS): Steady speed reference

ϵ (Pulse): Steady error (The number of pulses in the error counter at constant speed)

■ Adjustment

Follow the procedure below to make adjustment.

1. Calculate and set the motor axis converted load inertia.
2. Set the loop gain to a low value and increase speed loop gain within a range that does not cause noise or vibration to occur.
3. Slightly reduce the speed loop gain from the value in step 1, and increase position loop gain within a range that does not cause overshooting or vibration to occur.
4. Determine the speed loop integration time constant by observing the positioning time and vibration in the mechanical system. Positioning time may be increased if the speed loop integration time constant is too large.
5. It is not necessary to change the torque reference filter time constant unless torsional resonance occurs in the equipment shafts. Torsion resonance may be present if there high-frequency vibration noise. In this case, adjust the torque reference filter time constant to reduce the noise.
6. Finally, it is necessary to determine the optimum value for acceleration/deceleration to adjust finely the position and speed loop gain as well as the integration time constant.

■ Monitoring

The MECHATROLINK communication monitoring function can be used to read various monitors, display the monitor status at the host controller, and make any necessary adjustments. If monitoring cannot be made at the host controller, use the analog monitor. The analog monitor

can observe load torque or speed overshoot, but is not for monitoring vibration. Therefore, we recommend that monitoring should be made at the host controller.

Analog Monitoring

Motor speed and torque can be monitored via an analog signal while adjusting the gain. The cable connections and output signals needed for this are outlined below.

IMPORTANT

The cable is only loosely attached to the SGDB SERVOPACK connector, and an external force applied to it may cause it to disconnect. Do not connect meters or other devices to the cable in applications.

- **Connecting Monitoring Cables to an SGDB-□□□N SERVOPACK**

Use a DE9404559 cable from the 5CN connector for analog monitor output.

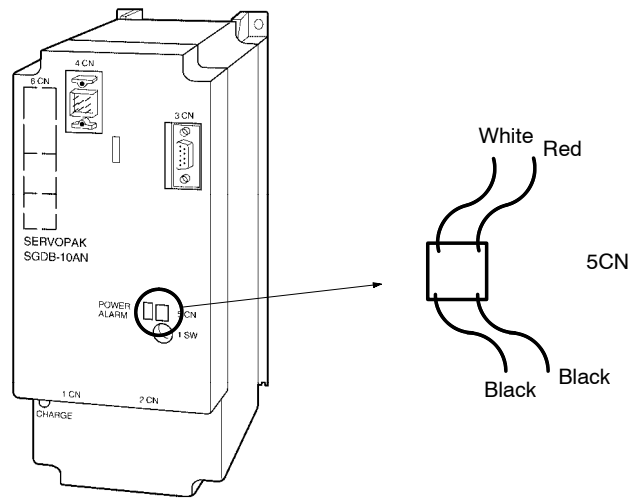
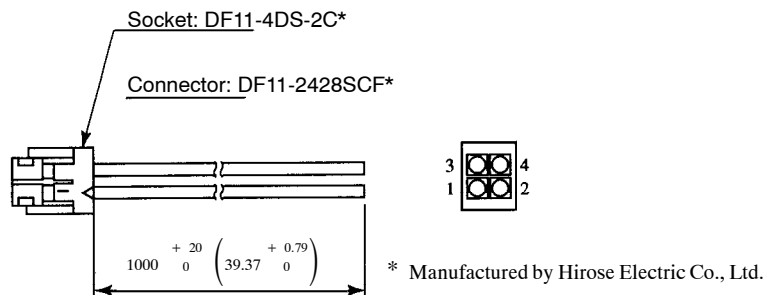

Figure 5.10 Enlarged View of the 5CN Section

Insert the cables that will be used for monitoring through the location marked with a circle in the figure above.

- **Dimension Diagram of the Monitoring Cables (DE9404559)**



- **Cable Colors and Monitor Signals**

Cable Color	Signal Name	Description
Red	VTG-M	Speed monitor SGMG, SGMD $\mp 2 \text{ V}/\pm 1000 \text{ r/min}$ SGMS, SGM, SGMP $\mp 1 \text{ V}/\pm 1000 \text{ r/min}$
White	TRQ-M	Torque monitor $\mp 2 \text{ V}/\pm 100\% \text{ torque}$
Black (2 wires)	GND	GND

5.9.3 Functions that Improve Response

The following functions are provided to improve response.

- Mode switching
- Feed-forward control
- Bias

These functions will not necessarily improve characteristics, and they can even have the opposite effect. Be sure to observe the precautions given below, and monitor the actual response of the characteristics while making adjustments.

■ Mode Switching

Mode switching is used to improve transient characteristics if the torque reference saturates during acceleration and deceleration. In other words, mode switching is a function that automatically switches the speed control mode inside the SERVOPACK from PI (proportional/integral) to P (proportional) control above a certain setting.

■ Feed-forward Control

Feed-forward control generally shortens positioning time, but has no effect on systems where the position loop gain is at its maximum. Adjust the amount of feed-forward control using Cn-001D as outlined below.

1. Adjust the speed and position loop.
2. Gradually increase the amount of feed-forward control set in Cn-001D until the positioning complete status (PSET) is output as quickly as possible.

A primary lag filter may be added to the feed-forward line to improve characteristics when the positioning complete signal is intermittent or when speed overshooting occurs due to excessive feed-forward control.

Make sure during adjustment that the position complete status (PSET) is not intermittent (repeatedly turning ON and OFF) and that the speed is not overshoot. Setting the amount of feed-forward control too high will cause an intermittent positioning complete status (changing from “1” to “0” and then to “1”) as well as speed overshooting.

■ Bias Control

When the number of pulses in the error counter exceeds the positioning complete width (Cn-001B), bias (Cn-001C) is added to the error counter output (speed reference) until the speed reference falls within the positioning complete width. This shortens the positioning time by reducing the number of pulses in the error counter.

Motor operation will become unstable if the bias is set too high. Adjust the bias while monitoring the response because the optimum value will vary with the gain and the positioning complete width.

Set Cn-001C to 0 if bias control will not be used.

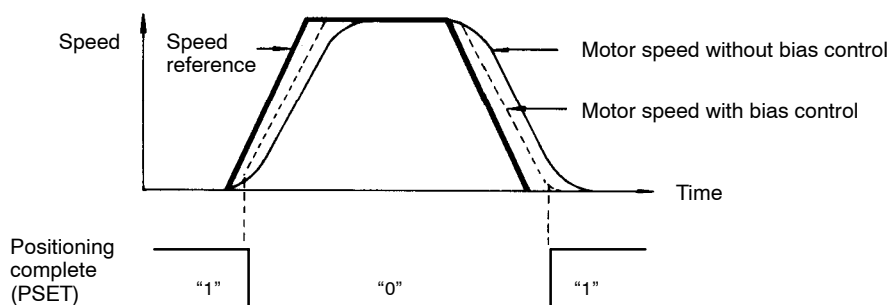

5.9.4 Guidelines for Setting the Load Inertia Ratio

Adjustment guidelines are given below based on the rigidity and load inertia of the mechanical system. These values are given as guidelines only, and vibration or poor response may occur within the given ranges. Monitor the response (waveform) to optimize the adjustment. Higher gain is possible with highly rigid machines.

■ Machines with High Rigidity

Machines with high rigidity include ball screws and direct-drive machines.

Examples: Chip Mounters, IC Bonders, Precision Machine Tools

Load Inertia Ratio (GD^2_L/GD^2_M) (Cn-0003) [%]	Position Loop Gain (Cn-001A) [0.01/s]	Speed Loop Gain (Cn-0004) [0.1 Hz]	Speed Loop Integration Time Constant (Cn-0005) [0.01ms]
1x (100)	5000 to 7000	500 to 700	500 to 2000
3x (300)			
5x (500)			

Note As the inertia ratio increases, set the position loop gain and speed loop gain to the lower limit of the range of values specified and increase the speed loop integration time constant.

■ Machines with Medium Rigidity

Machines with medium rigidity include machines driven by ball screws through reduction gears, or machines driven directly by long ball screws.

Examples: General Machine Tools, Orthogonal Robots, Conveyors

Load Inertia Ratio (GD^2_L/GD^2_M) (Cn-0003) [%]	Position Loop Gain (Cn-001A) [0.01/s]	Speed Loop Gain (Cn-0004) [0.1 Hz]	Speed Loop Integration Time Constant (Cn-0005) [0.01 ms]
1x (100)	3000 to 5000	300 to 500	1000 to 4000
3x (300)			
5x (500)			

Note As the inertia ratio increases, set the position loop gain and speed loop gain to the lower limit of the range of values specified, and increase the speed loop integration time constant.

■ Machines with Low Rigidity

Machines with low rigidity include machines driven by timing belts, chains, or wave reduction gears called Harmonic Drives.

Example: Conveyors, Articulated Robots

Load Inertia Ratio (GD^2_L/GD^2_M) (Cn-0003) [%]	Position Loop Gain (Cn-001A) [0.01/s]	Speed Loop Gain (Cn-0004) [0.1 Hz]	Speed Loop Integration Time Constant (Cn-0005) [0.01 ms]
1x (100)	1000 to 2000	100 to 200	5000 to 10000
3x (300)			
5x (500)			

Note As the inertia ratio increases, set the position loop gain and speed loop gain to the lower limit of the range of values specified, and increase the speed loop integration time constant.

6

MECHATROLINK Communication

This chapter describes MECHATROLINK communication specifications, commands and communication sequence and provides a list of alarms/warnings.

6.1 Specifications and Configuration	6 -2
6.1.1 Specifications	6 -2
6.1.2 Control Structure	6 -2
6.2 1SW Rotary Switch for MECHATROLINK Station Address Settings	6 -3
6.3 MECHATROLINK Command List	6 -4
6.4 Special Descriptions	6 -7
6.4.1 Option Field Specifications	6 -7
6.4.2 I/O Monitor Specifications	6 -8
6.4.3 Monitor 1/2 Type Field Specifications	6 -9
6.4.4 CONFIG Specifications	6 -10
6.4.5 ALM_RD Specifications	6 -10
6.4.6 ALM_CLR Specifications	6 -11
6.4.7 CONNECT Specifications	6 -11
6.4.8 INTERPOLATE Specifications	6 -12
6.4.9 LATCH (Interpolation Feed with Position Detection) Specifications	6 -12
6.4.10 POSING Command Specifications	6 -13
6.4.11 INTERPOLATE Command Specifications	6 -13
6.4.12 ID_RD (ID Read) Specifications	6 -13
6.4.13 Unsupported Commands	6 -14
6.5 Power ON Sequence (Communications Sequence)	6 -15
6.6 List of Alarm and Warning Codes	6 -18

6.1 Specifications and Configuration

6.1.1 Specifications

Items that are not described in this chapter are based on the MECHATROLINK application layer. For more details refer to the following manuals.

MECHATROLINK System User's Manual (SIE-S800-26.1)

MECHATROLINK Servo Command User's Manual (SIE-S800-26.2)

6.1.2 Control Structure

The following illustration shows control structure. Up to 15 axes can be connected.

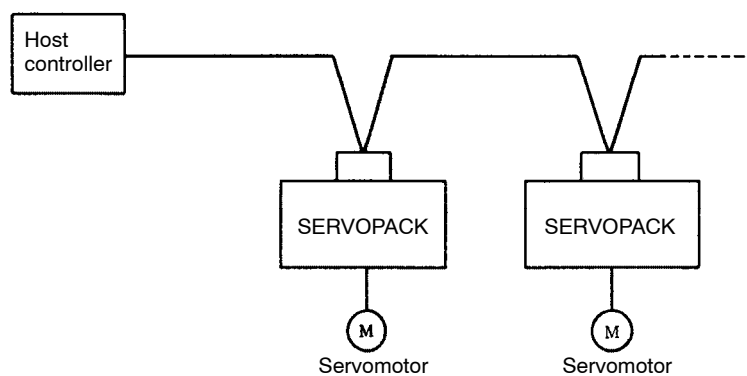

6.2 1SW Rotary Switch for MECHATROLINK Station Address Settings

1SW sets the MECHATROLINK station address, and is used to select one of the following SGDB-□□□N addresses.

SW1	Station Address
0	Not used (Do not set.)
1	41H (Factory setting)
2	42H
3	43H
4	44H
5	45H
6	46H
7	47H
8	48H
9	49H
A	4AH
B	4BH
C	4CH
D	4DH
E	4EH
F	4FH

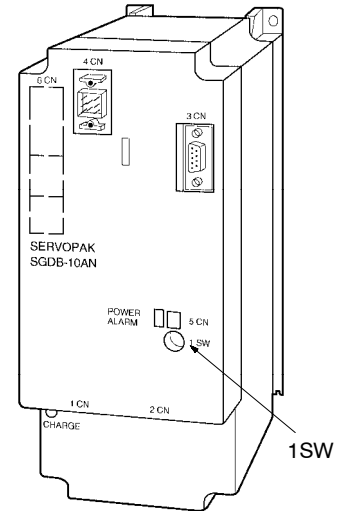

Note This switch setting is read only when power is turned ON.
To change settings, turn OFF the power and turn it ON again.

6.3 MECHATROLINK Command List

MECHATROLINK common commands, motion common commands, and servo standard commands are shown in the following tables.

Table 6.1 MECHATROLINK Common Command Group

Code	Command	Function	Processing Classification	Synchronization Classification	Remarks
00	NOP	No Operation	N	A	
01	PRM_RD	Read parameter	D	A	
02	PRM_WR	Write parameter	D	A	
03	ID_RD	Read ID	D	A	See note 1.
04	CONFIG	Set up devices	C	A	See note 1.
05	ALM_RD	Read alarm or warning	D	A	See note 1.
06	ALM_CLR	Clear alarm or warning	C	A	See note 1.
07					
08					
09					
0A					
0B					
0C					
0D	SYNC_SET	Start synchronous communication	N	A	
0E	CONNECT	Establish connection	N	A	See note 1.
0F	DISCONNECT	Release connection	N	A	
10					
11					
12					
13					
14					
15					
16					
17					
18					
19					
1A					
1B	PPRM_RD	Read EEPROM user constants	D	A	
1C	PPRM_WR	Write EEPROM user constants	D	A	
1D					
1E					
1F					

Table 6.2 MECHATROLINK Common Motion Command Group

Code	Command	Function	Processing Classification	Synchronization Classification	Remarks
20	POS_SET	Set coordinates	D	A	
21	BRK_ON	Apply brake	C	A	
22	BRK_OFF	Release brake	C	A	
23	SENS_ON	Turn ON sensor	C	A	
24	SENS_OFF	Turn OFF sensor	C	A	
25	HOLD	Stop motion	M	A	
26					
27					
28					
29					
2A					
2B					
2C					
2D					
2E					
2F					
30	SMON	Status monitoring	D	A	
31	SV_ON	Servo ON	C	A	
32	SV_OFF	Servo OFF	C	A	
33					
34	INTERPOLATE	Interpolation feed	M	S	See note 1.
35	POSING	Positioning	M	A	See note 1.
36	FEED	Manual feed	M	A	See note 1.
37					
38	LATCH	Interpolation feeding with position detection	M	S	See note 1.
39	EX_POSING	External input positioning	M	A	See note 1.
3A	ZRET	Origin return	M	A	See note 1.
3B					
3C					
3D					
3E	ADJ	Adjusting	X	A	See note 2.
3F	SVCTRL	General-purpose servo control	X	A(S)	See note 2.

Note 1. Addition or change unique to SGDB-□□□N. (See Chapter 6.4.)

2. Not supported by SGDB-□□□N.

The following abbreviations are used for processing and synchronization classifications.

Processing Classifications		Synchronization Classifications	
N	Network command	A	Asynchronous command
D	Data communication command	S	Synchronous command
C	Control command		
M	Motion command		
X	Compound command		

6.4 Special Descriptions

The following describes specific items unique to the SGDB-□□□N.

6.4.1 Option Field Specifications

1	Command
2	
3	Options
4	
5	
6	
7	
8	
9	
10	
11	
12	
13	Monitor 1/2 type
14	
15	
16	WDT

The third and fourth bytes of the reference data field for motion commands are reserved for options used to add motion command functions for each product.

Option fields are used in the SGDB-□□□N for speed loop P/PI control switching and acceleration/deceleration filter selection.

- Appropriate commands for options.
Followings are appropriate commands for option fields.
SV_ON, INTERPOLATE, POSING, FEED, LATCH,
EX_POSING, ZRET

In SGDB-□□□N option field, the third byte is used for acceleration/deceleration filter type selection and the fourth byte is used for speed loop P/PI control switching.

Option	
3	Acceleration/deceleration filter type selection
4	Speed loop P/PI control switch

■ Acceleration/Deceleration Filter Selection

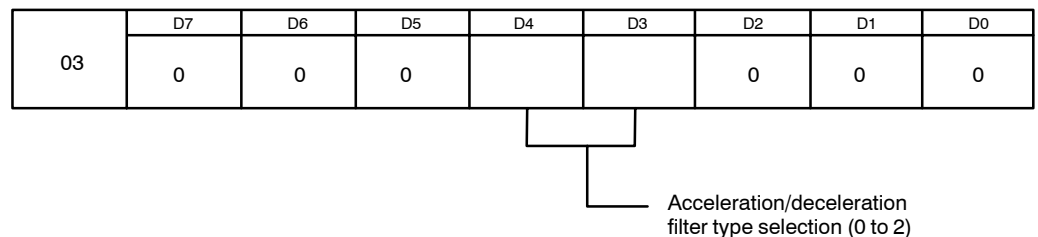

Acceleration/Deceleration Filter Type Selection (D3 and D4)

Three types of acceleration and deceleration can be selected with the SGDB-□□□N.

Type	Acceleration/Deceleration Filter Type	Related Parameters
0	Linear acceleration/deceleration (no filter)	-
1	Exponential acceleration/deceleration	Cn-002D, 002E
2	S-curve acceleration/deceleration (running average)	Cn-0026

IMPORTANT

- All bits except D3 and D4 must be set to 0.
- Acceleration/deceleration types can only be switched when DEN (acceleration/deceleration filter output complete) is set to 1. Never switch acceleration/deceleration types when DEN is set to 0. Yaskawa cannot guarantee how the SERVOPACK will act if the two items above are not followed exactly.

■ Speed Loop P/PI Control Switching

	D7	D6	D5	D4	D3	D2	D1	D0
04	0	0	0		0	0	0	0

Speed loop P/PI control switching (1: P control)

- Speed Loop P Control Switching (D4)
The SGDB-□□□N is has a function that switches the speed loop between PI and P control in real time.

D4	Speed Loop Control
0	PI control (switches to P control via mode switch settings)
1	P control

This function suppresses undershooting and shortens positioning complete time when the Servomotor is stopped.

IMPORTANT

All bits except D4 must be set to 0, otherwise Yaskawa cannot guarantee how the SERVOPACK will act.

6.4.2 I/O Monitor Specifications

N-OT and P-OT are output monitoring as a logic OR with the software limits (N-SOT, P-SOT). The OT is output as the OT (overtravel) even at the software limits.

6.4.3 Monitor 1/2 Type Field Specifications

1	Command
2	
3	Option
4	
5	
6	
7	
8	
9	
10	
11	
12	
13	Monitor 1/2 type
14	
15	
16	WDT

The monitor 1/2 type, the thirteenth byte of the reference data field of commands, is reserved to select monitor data that will be returned.

The following types of monitoring are available with the SGDB-□□□N.

- Appropriate commands for monitor 1/2 type
SMON, SV_ON, SV_OFF, INTERPOLATE, POSING, FEED, LATCH, EX_POSING, ZRET

The following table outlines the data (codes) and monitoring contexts of monitor 1/2 type.

Name	Code	Description	Units
POS	0	Position in the reference coordinate system	Reference units
MPOS	1	Position in the mechanical coordinate system	Reference units
PERR	2	Position error	Reference units
APOS	3	Absolute position	Reference units
LPOS	4	Counter latch position	Reference units
IPOS	5	Internal position in the reference coordinate system	Reference units
TPOS	6	Final target position	Reference units
–	7	–	–
FSPD	8	Feedback speed	Reference units/s
CSPD	9	Reference speed	Reference units/s
TSPD	A	Final target reference speed	Reference units/s
TRQ	B	Torque reference	Reference units
–	C	–	%
–	D	–	–
–	E	–	–
–	F	–	–

- Note 1.** The minus (–) sign indicates unused bits. Do not use them.
- 2.** Feedback speed is approx. 20 [reference unit/s] (factory setting) and reference speed is a resolution of 500 [reference unit/s].

6.4.4 CONFIG Specifications

The following user constants can be reset in CONFIG (equipment setup) command for SGDB-□□□N.

Cn-0001	Memory switch 1
Cn-0002	Memory switch 2
Cn-0011	No. of encoder pulses

6.4.5 ALM_RD Specifications

Byte	Command	Response
1	ALM_RD	ALM_RD
2		ALARM
3		STATUS
4		
5	ALM_RD_MODE	ALM_RD_MODE
6		ALM_DATA
7		
8		
9		
10		
11		
12		
13		
14		
15		
16	WDT	RWDT

The ALM_RD_MODE at the fifth byte of ALM_RD (read alarm/warning status) is the field used to select objects that will be read, and it can be specified for each product.

The following are ALM_RD_MODE specifications for the SGDB-□□□N.

ALM_RD_MODE	Description
0	Read current alarm/warning status 10 items max. (sixth to fifteenth byte)
1	Read alarm/warning status history 10 items max. (sixth to fifteenth byte)

Note Alarm and warning history occurrences are saved on EEPROM, and will not be lost if power goes OFF.

6.4.6 ALM_CLR Specifications

1	ALM_CLR
2	
3	
4	
5	ALM_CLR_MODE
6	
7	
8	
9	
10	
11	
12	
13	
14	
15	
16	WDT

The ALM_CLR_MODE at the fifth byte of ALM_CLR (clear alarm/warning status) is the field used to select objects that will be cleared, and it can be specified for each product.

The following are ALM_CLR_MODE specifications for the SGDB-□□□N.

ALM_CLR_MODE	Description
0	Clear current alarm/warning status
1	Clear alarm/warning status history

Note It takes approx. 100 ms to clear. Do not clear alarm/warning status history occurrences while the motor is driving.

6.4.7 CONNECT Specifications

1	CONNECT
2	
3	
4	
5	VER
6	COM_MODE
7	COM_TIME
8	
9	
10	
11	
12	
13	
14	
15	
16	WDT

CONNECT (establish connection) is limited in the SGDB-□□□N to the following items.

- COM_MODE

D7	D6	D5	D4	D3	D2	D1	D0
				DTMOD		SYNCMOD	EXMOD

DTMOD: Data transfer method
10: Multiple is not supported.

- COM_TIME
Use $2 \leq \text{COM_TIME} \leq 32$.

6.4.8 INTERPOLATE Specifications

1	INTERPOLATE
2	
3	Option
4	
5	Interpolation position
6	
7	
8	
9	Speed feed forward
10	
11	
12	
13	Monitor type 1/2
14	
15	
16	WDT

The speed feed forward function is not supported in INTERPOLATE (interpolation feed) with the SGDB-□□□N.

Always set the speed feed forward field between the ninth and twelfth bytes to 0.

6.4.9 LATCH (Interpolation Feed with Position Detection) Specifications

1	LATCH
2	Latch signal select
3	Option
4	
5	Interpolation position
6	
7	
8	
9	Speed feed forward
10	
11	
12	
13	Monitor type 1/2
14	
15	
16	WDT

The speed feed forward function is not supported in LATCH (interpolation feed with position detection) with the SGDB-□□□N.

Always set the speed feed forward field between the ninth and twelfth bytes to 0.

Latch Signal Delays

C-phase: Within 1 μs

External signal: Approx. 50 μs
(with 24 VDC input)

Set the external signal so that Low section will exceed 500 μs as shown below.

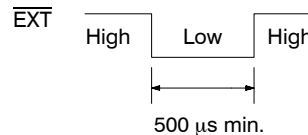

6.4.10 POSING Command Specifications

There is a limit to the resolution of the acceleration/deceleration constants and feed speed when positioning with commands like the POSING command. These resolutions are given below. The INTERPOLATE command can be used when higher resolution is required.

- Acceleration/deceleration constants (CN-001F and Cn-0020):
15625 reference units/s² (factory setting)
This value changes with the number of reference units per revolution.
- If the number of reference units per revolution is 13653 or less, the resolution will be 15625 reference units/s². If it exceeds 13653, the resolution will be 250000 reference units/s². The acceleration/deceleration time is 8.19s maximum, and it is 1 s maximum with a FEED command.
- Feed speed: Approx. 2 reference units/s
The feed speed cannot exceed 16383500 reference units/s.

6.4.11 INTERPOLATE Command Specifications

The interpolation feed speed for the INTERPOLATE command and other interpolation commands cannot exceed 16383500 reference units/s when expressing the amount of movement for one reference as a feed speed.

6.4.12 ID_RD (ID Read) Specifications

1	ID_RD
2	
3	
4	
5	DEVICE_CODE
6	OFFSET
7	SIZE
8	
9	
10	
11	
12	
13	
14	
15	
16	WDT

The DEVICE_CODE is available only with “00H: Main device/Product type” and “02H: Software version,” because hardware limits use of the ID_RD function in the SGDB-□□□N.

The following are IDs that can be read.

DEVICE_CODE	ID Description															
	00	01	02	03	04	05	06	07	08	09	0A	0B	0C	0D	0E	0F
00H	S	G	D	B	-	*	*	*	N	00	Undefined					
02H	Software version		Undefined													

Note 00 to 08 are ASCII code, 09 is 00H, and the software version is binary data.

6.4.13 Unsupported Commands

Do not use the following commands because they are not supported in the SGDB-□□□N.

Code	Name	Function
3E	ADJ	Adjustment
3F	SVCTRL	General-purpose servo control

6.5 Power ON Sequence (Communication Sequence)

The following is a typical power ON sequence (communication sequence).

1. Turn ON the control power supply.

2. Make communication connection (CONNECT command).

When communication connection has been completed, confirm the following: COMRDY=1 and SVALM=0. Also confirm the MECHATROLINK version.

↓

3. Check device ID, etc.

Confirm that the ID is “SGDB-***N”. Also confirm the software version.

↓

4. Write required parameters by PRM_WR command. (Set up the equipment (CONFIG command))

↓

5. Turn encoder (sensor) power ON (SENS_ON command).

When the power has been turned ON, confirm the following status: COMRDY=1.

↓

6. Turn ON the main power supply. (Confirm the following status: PON = 1 when power ON is completed.) It takes about 0.6 s from power ON until power ON is completed.

↓

7. Main circuit ON (SV_ON command).

When the main circuit has been turned ON, confirm the following status: SVON=1.

↓

8. Operation starts.

:

9. Main circuit OFF (SV_OFF command).

When the main circuit has been turned OFF, confirm the following status: SVON=0.

↓

10. Turn OFF the main power supply.

11. Communication disconnected (DISCONNECT command)

↓

12. Turn control power supply OFF.

After turning ON the control power, transfer the NOP command or CONNECT command until communication connection has been completed.

The controller always has the required parameters and ensures proper controller operation by transferring the parameters at power ON. We recommend using this method at all times because the controller can then manage the parameters even if the SERVOPACK or motor is replaced.

There is also an alternative method shown on the next page where the SERVOPACK has all parameters (non-volatile parameters).

Non-volatile parameters are saved on EEPROM and cannot be changed very often. Also when absolute encoder is selected, the encoder cannot be changed to an incremental encoder without turning power ON/OFF. (Effect at the next power ON)

First write parameters to the SERVOPACK offline.

1. Turn control power ON.
↓
2. Communication connection (CONNECT command)
↓
3. Check device ID, etc.
↓
4. Write required non-volatile parameters by PPRM_WR command.

When writing has been completed (ready for next writing), confirm the following status: COMRDY=1.

- ↓
5. Communication disconnected (DISCONNECT command)
↓
6. Turn control power OFF.

The following is a typical example (no parameters transferred).

1. Turn control power supply ON.
↓
2. Communication connection (CONNECT command)
When communication connection has been completed, confirm the following status: COMRDY=1 and SVALM=0. Also confirm the MECHATROLINK version.
↓
3. Check device ID, etc. (Use the equipment setup (CONFIG command))
Confirm that ID is "SGDB-***N". Also confirm the software version.
↓
4. Turn encoder (sensor) power ON (SENS_ON command).
When the power has been turned ON, confirm the following status: COMRDY=1.
↓
5. Turn ON the main power supply. (Confirm the following status: PON = 1 when power ON is completed.) It takes about 0.6 s from power ON until power ON is completed.
↓

6. Main circuits ON (SV_ON command).

When the main circuit has been turned ON, confirm the following status: SVON=1.



7. Operation starts.

:

8. Main circuit OFF (SV_OFF command) and turn OFF the main power supply.



9. Communication disconnected (DISCONNECT command)



10. Turn control power supply OFF.

6.6 List of Alarm and Warning Codes

Code	Name	Alarm type
99	Normal	–
94	User constant setting warning	Warning
95	MECHATROLINK command warning	Warning
96	MECHATROLINK communication warning	Warning
00	Absolute encoder data error	Servo alarm
02	Broken user constant	Servo alarm
05	Alarm history overflow	Servo alarm
10	Overcurrent	Servo alarm
11	Ground	Servo alarm
30	Regeneration error detected	Servo alarm
40	Overvoltage	Servo alarm
41	Undervoltage	Servo alarm
51	Overspeed	Servo alarm
71	Overload (instantaneous)	Servo alarm
72	Overload (continuous)	Servo alarm
7A	Heat sink overheated	Servo alarm
80	Absolute encoder error	Servo alarm
81	Absolute encoder backup error	Servo alarm
82	Absolute encoder checksum error	Servo alarm
83	Absolute encoder battery error	Servo alarm
84	Absolute encoder data error	Servo alarm
85	Absolute encoder overspeed	Servo alarm
B1	Gate array 1 error	Servo alarm
B2	Gate array 2 error	Servo alarm
B3	Phase-U current feedback error	Servo alarm
B4	Phase-V current feedback error	Servo alarm
B5	Watchdog detector error	Servo alarm
B6	Main power supply circuit error	Servo alarm
C1	Servo overrun	Servo alarm
C2	Encoder phase detection error	Servo alarm
C3	Encoder phase-A and phase-B disconnection	Servo alarm
C4	Encoder phase-C disconnection	Servo alarm
C5	Incremental encoder initial pulse error	Servo alarm
D0	Position error overflow	Servo alarm
E5	MECHATROLINK synchronization error	Communication alarm
E6	MECHATROLINK communication error	Communication alarm
F1	Power supply line not connected	Servo alarm

7

User Constants

This chapter describes the contents and settings of user constants (parameters) and memory switches.

7.1	Setting User Constants	7 -2
7.1.1	Basic User Constants	7 -2
7.1.2	Gain-related Constants	7 -2
7.1.3	Torque-related Constants	7 -3
7.1.4	Sequence-related Constants	7 -4
7.1.5	Motion-related Constants	7 -5
7.1.6	Other Constants	7 -8
7.1.7	Memory Switches	7 -9
7.2	List of User Constants	7 -13
7.3	Memory Switch Bit Details	7 -16
7.3.1	Cn-0001: Memory Switches 1	7 -16
7.3.2	Cn-0002: Memory Switches 2	7 -18
7.3.3	Cn-0013: Memory Switches 3	7 -19
7.3.4	Cn-0014: Memory Switches 4	7 -20
7.4	Limits to User Constant Changes	7 -22
7.5	Procedure for Transferring User Constants	7 -23

7.1 Setting User Constants

The following user constants (parameters) are available with the SERVOPACK. Set or change the user constants to fit your system.

7.1.1 Basic User Constants

The following basic user constants are available.

■ Cn-0037: Servomotor Selection

Selects the Servomotor, but the setting can be changed only once after power is turned ON. Cn-0037 is set by the type of Servomotor used, so set the correct Servomotor type. *Table 7.1* (page 7 -23) shows Servomotor codes. Do not change this setting during motor running.

■ Cn-0011: Number of Encoder Pulses

Sets the number of pulses per encoder revolution. The setting can be changed only once after power is turned ON; do not change the setting during motor running.

■ Cn-0003: Load Inertia

Sets the load inertia for the moment of inertia ratio on the motor shaft. The allowable setting range is 0 to 65535 [%], but regeneration and other factors must be considered if the Servomotor exceeds the allowable load inertia. See 5.6.2 (page 5 -10).

7.1.2 Gain-related Constants

The following gain-related user constants are available.

■ Cn-0004: Speed Loop Gain

- Sets the proportional gain for the speed controller.
- Allowable setting range: 1 to 20000 [$\times 0.1$ Hz]
- Sets the constant at 40 [Hz] maximum when the motor is running under no-load conditions.

■ Cn-0005: Speed Loop Integration Time Constant

- Sets the integration time constant for the speed controller.
- Allowable setting range: 100 to 65535 [$\times 0.01$ ms]

■ Cn-001A: Position Loop Gain

- Sets the proportional gain for the position controller.
- Allowable setting range: 1 to 50000 [$\times 0.01$ /s]

■ Cn-001C: Bias

- Sets the position control bias. This constant is used depending on load conditions to shorten positioning time.
- Allowable setting range: 0 to maximum motor speed [\times 100 reference units/s]

■ Cn-001D: Feed Forward Compensation

- Sets the feed forward compensation for the position controller.
- Allowable setting range: 0 to 100 [%]

■ Cn-0027: Feed Forward Reference Filter

- Sets the primary lag filter to add to the feed forward compensation.
- This constant can be used to reduce the impact of feed forward control.
- Allowable setting range: 0 to 64000 [μ s]

7.1.3 Torque-related Constants

The following torque-related user constants are available.

■ Cn-0006: Emergency Stop Torque

- Sets the stopping torque (deceleration by emergency stop torque with deceleration constant Cn-0001 bit 8 set to 1) for overtravel.
- Allowable setting range: 0 to maximum torque [%]

■ Cn-0008: Forward Torque Limit

- Sets the motor torque limit for forward rotation (for reverse rotation with reverse rotation mode).
- The motor torque will be controlled within this limit during forward rotation.
- Allowable setting range: 0 to maximum torque [%]

■ Cn-0009: Reverse Torque Limit

- Sets the motor torque limit for reverse rotation.
- The motor torque will be controlled within this limit during reverse rotation.
- Allowable setting range: 0 to maximum torque [%]

■ Cn-0017: Torque Reference Filter Time Constant

- Sets the primary lag filter to add to the reference torque for speed error and speed loop gain.
- This constant is used to prevent vibration due to mechanical resonance.
- Allowable setting range: 0 to 25000 [μ s]

■ Cn-0018: Torque Reference Filter Time Constant (Secondary)

- Sets a secondary lag filter. The filtering effect can be improved by applying a secondary lag filter to the reference torque.

- Specifying a value other than 0 applies a secondary lag filter.
- Allowable setting range: 0 to 25000 [μ s]

7.1.4 Sequence-related Constants

The following sequence-related user constants are available.

■ Cn-0012: Time Delay from Brake Reference to Servo OFF

- Sets the time delay from the brake reference output to Servo OFF when a Servomotor with a brake is used.
- Allowable setting range: 0 to 50 [\times 10 ms]

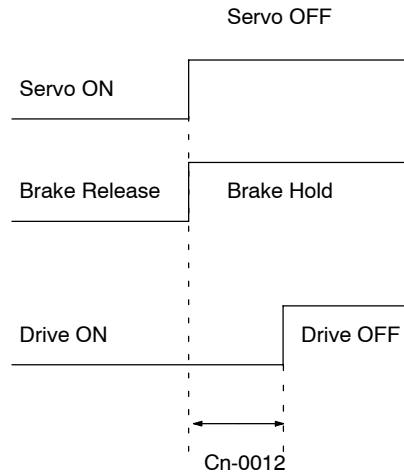

■ Cn-0015: Brake Timing During Motor Running (Motor Speed for Brake ON Reference)

- Sets the motor speed at which a brake reference is turned ON during servo OFF.
- If the motor speed is faster than this setting speed, the brake is releasing.
- Allowable setting range: 0 to maximum motor speed [r/min]

Note The setting value of Cn-0015 must be smaller than the number of motor rotation.

■ Cn-0016: Time Delay from Servo OFF to Forced Brake ON During Motor Running

- Sets the time delay from Servo OFF until the brake ON.
- The mechanical brake is not immediately applied when the motor speed is faster than the speed that was set to Cn-0015 after Servo is turned OFF. When the setting time has passed, the brake hold regardless of the motor speed.
- Allowable setting range: 10 to 100 [\times 10 ms]

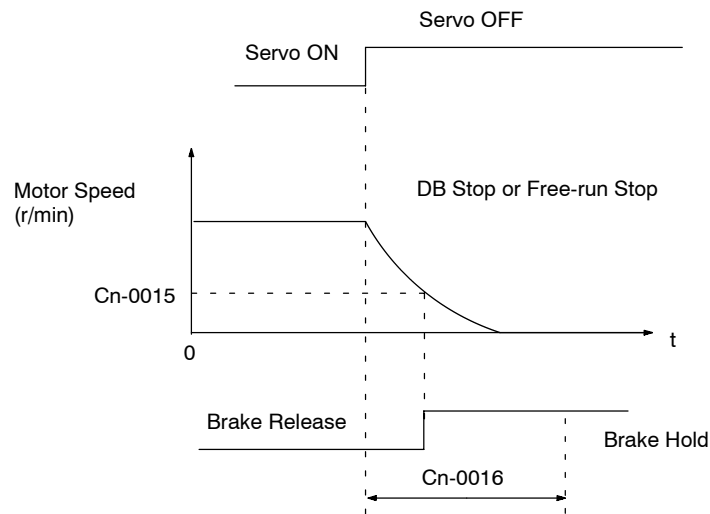

7.1.5 Motion-related Constants

The following motion-related user constants are available.

■ Cn-0024 (B) and Cn-0025 (A): Electronic Gear Ratio

- The electronic gear ratio $\frac{B}{A} \left(\frac{Cn-0024}{Cn-0025} \right)$ represents the number of encoder pulses per reference unit.

For example, consider a system where the reference unit is micrometers in equipment that drives a ball screw with a 5-mm (0.20-in) pitch using a Servomotor with an incremental encoder (8192 pulses). Since 8192 encoder pulses are generated 4 times (unconditionally 4 times) in one motor revolution, the number of pulses generated is 8192×4 or 32768 pulses. Here, the Servomotor moves 5 mm (0.20 in) above the 5-mm (0.20-in) pitch ball screw, and this distance expressed as micrometers is 5000 μm . Therefore, set Cn-0024 to 32768 and Cn-0025 to 5000.

- Make sure that the electronic gear ratio falls within the range $0.01 \leq B/A \leq 100$.
- Be sure to recalculate and correct user constants set in reference and speed reference units. Do not change this setting during motor running.

■ Cn-001F: First-step Linear Acceleration/Deceleration Constant

- Sets the first-step acceleration/deceleration when two-step acceleration/deceleration is used.
- When two-step acceleration/deceleration is not used, set the first-step acceleration/deceleration speed and the acceleration/deceleration constant switching speed (Cn-0021) to 0.
- Allowable setting range: 0 to 65535 [$\times 10000$ reference units/s²]

■ Cn-0020: Second-step Linear Acceleration/Deceleration Constant

- Sets the second-step acceleration/deceleration.
- Allowable setting range: 0 to 65535 [$\times 10000$ reference units/s²]

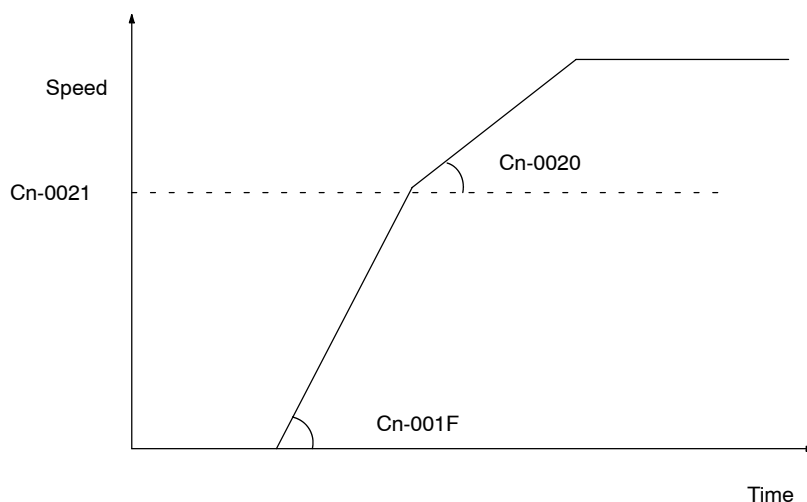

■ Cn-0021: Acceleration/Deceleration Constant Switching Speed

- Sets the speed for switching from the first-step to the second-step acceleration/deceleration in two-step acceleration/deceleration.
- Allowable setting range: 0 to 65535 [$\times 100$ reference units/s]

■ Cn-0026: Running Average Time

- Sets the time of running average for S-curve acceleration/deceleration.
- This constant is used for S-curve acceleration/deceleration.
- Allowable setting range: 0 to 5100 [$\times 100 \mu\text{s}$]
- Running average is not valid when “0” is set.

■ Cn-002D: Exponential Acceleration/Deceleration Bias

- Sets bias to change linear acceleration/deceleration to exponential acceleration/deceleration.
- Allowable setting range: 0 to 32767 [$\times 500$ reference units/s]

■ Cn-002E: Exponential Acceleration/Deceleration Time Constant

- Sets the time constant to change linear acceleration/deceleration to exponential acceleration/deceleration.
- Allowable setting range: 0 to 5100 [$\times 100 \mu\text{s}$]
- Exponential acceleration/deceleration is not valid when “0” is set.

■ Cn-0022: Zero Point Return Approach Speed 1

- Sets the approach speed for returning to the zero point after the deceleration limit switch signal turns ON.
- Allowable setting range: 0 to 65535 [$\times 100$ reference units/s]

■ Cn-0023: Zero Point Return Approach Speed 2

- Sets the speed to search for the zero point after the deceleration limit switch signal turns ON or OFF.

- Allowable setting range: 0 to 65535 [\times 100 reference units/s]
- **Cn-0028: Final Travel Distance To Return To Zero Point**
- Sets the distance from the encoder zero point pulse (phase-C pulse) to the zero point when returning to the zero point.
 - Allowable setting range: -2147483648 to +2147483647 [reference units]
 - If the setting distance is reverse direction or a short travel distance, the motor will decelerate to a stop and then return to reverse direction.
- **Cn-002A: Zero Point Width**
- Sets the zero point (ZPOINT) detection width.
 - Allowable setting range: 0 to 65535 [reference units]
- **Cn-0033: Absolute Encoder Zero Point Offset**
- Sets the difference between the encoder zero point (position 0) and the machine zero point if an absolute encoder is used. For example, set the amount of offset so that the machine zero point is position 0.
 - Allowable setting range: -2147483648 to +2147483647 [reference units]
- **Cn-002B: Final Travel Distance for External Positioning**
- Sets the distance from the external signal input during external positioning.
 - Allowable setting range: -2147483648 to +2147483647 [reference units]
 - If the setting distance is reverse direction or a short travel distance, the motor will decelerate to a stop and then return to reverse direction.
- **Cn-002F: Forward Software Limit**
- Sets the forward software position limit.
 - Allowable setting range: -2147483648 to +2147483647 [reference units]
 - The positive software limit must be set in combination with the reverse software limit to specify the range of motion. Make sure that the forward software limit is greater than the reverse software limit.
- **Cn-0031: Reverse Software Limit**
- Sets the reverse software position limit.
 - Allowable setting range: -2147483648 to +2147483647 [reference units]
- **Cn-001B: Positioning Completed Width**
- Sets the positioning completed width (PSET).
 - Allowable setting range: 0 to 250 [reference units]
- **Cn-0007: Positioning Near Detection Width**
- Sets the detection width for positioning nearly completed (NEAR).

- When the motor position moves within this range for the target position, NEAR is set to 1 regardless of whether command distribution is completed.
- Allowable setting range: 0 to 10000 [reference units]

■ Cn-001E: Position Error Overflow Range

- Sets the overflow detection level of the position error counter.
- Allowable setting range: 1 to 65535 [reference units]
- If the number of reference units per motor revolution (no. of encoder pulses $\times 4 \times A/B$) is 8193 or more, the range is the setting $\times 128$. Therefore, the allowable setting range is 1 to 65535 [$\times 128$ reference units].

7.1.6 Other Constants

The following user constants are also available.

■ Cn-000C: Torque Reference Mode Switch Level

- Sets the torque reference mode switch level.
- This constant is valid only when torque reference mode switch is selected at Cn-0001 bits 12 and 13.
- Allowable setting range: 0 to maximum motor torque [%]

■ Cn-000E: Acceleration Mode Switch Level

- Sets the acceleration mode switch level.
- This constant is valid only when acceleration mode switch is selected at Cn-0001 bits 12 and 13.
- Allowable setting range: 0 to 3000 [$\times 0.167 \text{ r/s}^2$]

■ Cn-000F: Error Pulses Mode Switch Level

- Sets the mode switch level for switching the mode by error pulses.
- This constant is valid only when error pulses mode switch is selected at Cn-0001 bits 12 and 13.
- Unit: encoder pulses
- Allowable setting range: 0 to 10000 [pulses]

■ Cn-0035: Speed Loop Compensation Constant

- The speed loop compensation function compensates for a phase shift resulting from speed detection in digital control and is effective in reducing vibrations.
- When using this function, set Cn-0035 within a range that does not cause vibrations in the servo system or abnormal noise in the mechanical system.
- The speed loop compensation function may not be effective in some cases and vibrations may increase as a result. In that case, do not use the function (set Cn-0035 to 0).

- Allowable setting range: 0 to 100 (0: no compensation)

■ Cn-0038: Changing PG Power Supply Voltage

- The encoder power supply voltage must be 4.75 to 5.25 V at the encoder input section. Change the power supply voltage based on factors like the length of the encoder cable and use the following values as guidelines for standard cables.

Encoder	Cable Length				
	3 m (9.84 ft)	5 m (16.40 ft)	10 m (32.81 ft)	15 m (49.21 ft)	20 m (65.62 ft)
Incremental Encoder	52500			54000	55500
12-bit Absolute Encoder					
15-bit Absolute Encoder				55000	57000

Note Faulty operation or damage can result from setting the value too high or too low. The allowable setting range is 52000 to 58000 [$\times 0.1$ mV].

7.1.7 Memory Switches

The settings and functions of the memory switches are described below.

■ Cn-0001 Bit 0: SV_ON Command Mask

- The SV_ON command is disabled when this bit is set to 1 (main circuit operating status).

■ Cn-0001 Bit 1: SENS_ON Command Mask

- The SENS_ON command is disabled when this bit is set to 1 (encoder power ON status).

■ Cn-0001 Bit 2: P-OT Mask

- The P-OT signal is disabled when this bit is set to 1 (P-OT input OFF status).

■ Cn-0001 Bit 3: N-OT Mask

- The N-OT signal is disabled when this bit is set to 1 (N-OT input OFF status).

■ Cn-0001 Bit 6: Base Block Stopping Method

- Sets whether to use the dynamic brake or coasting to stop the motor when the main circuit is not operating (base block).
- Motor coasts to a stop when this bit is set to 1.

■ Cn-0001 Bit 7: Operation After Dynamic Brake (DB) Stop

- Sets whether to continue the dynamic brake after a dynamic brake stop.
- The brake is continued when this bit is set to 1.

■ Cn-0001 Bit 8: Overtravel (OT) Stopping Method

- Sets how to stop a motor when overtravel occurs.
OT occurs at forward/reverse drive (overtravel) input and soft limit.

- The motor decelerates to a stop with the torque specified in the emergency stop torque constant (Cn-0006) when Cn-0001 bit 8 is set to 1.

■ **Cn-0001 Bit 9: Holding Method After An Emergency Torque Deceleration Stop at Overtravel**

- Sets the holding method after an emergency torque deceleration stop when overtravel occurs.
- Zero clamping (by position control) after the motor stops when Cn-0001 bit 9 is set to 1. Normally set this to 1.

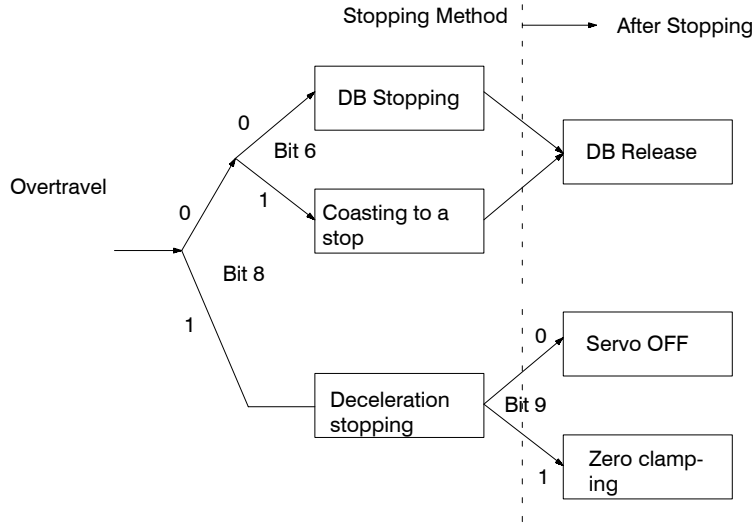

Stop Sequence in the Overtravel (OT)

■ **Cn-0001 Bit 10: Servo OFF Position Error**

- The position error is held when Cn-0001 bit 10 is set to 1.

■ **Cn-0001 Bit 11: Mode Switch Function**

- Sets whether the mode switch function will be used.
- The function is disabled when Cn-0001 bit 11 is set to 1.

■ **Cn-0001 Bits 12 And 13: Mode Switch Selection**

- Selects mode switch switching conditions. See 5.9.2 (pages 5 -20) for details on the mode switch.

Bits 13 and 12 = 0, 0: Torque
 Bits 13 and 12 = 0, 1: Nothing (Do not use this setting.)
 Bits 13 and 12 = 1, 0: Acceleration
 Bits 13 and 12 = 1, 1: Error pulse

- The mode switch switching level can be set by Cn-000C to Cn-000F.

■ **Cn-0001 Bit 14: Encoder Selection**

- Sets Cn-0001 bit 14 to 0 for an incremental encoder and to 1 for an absolute encoder.
- The setting can only be changed once after power is turned ON, but do not change the setting during motor running.

■ Cn-0002 Bit 0: Motor Rotation Direction

- Sets the motor rotation direction.
- Determines whenever Cn-0002 bit 0 or 2CN-7 is the reverse rotation with a reverse rotation setting.
- The forward direction is clockwise when Cn-0002 bit 0 is set to 1. (Reverse Rotation Mode).

■ Cn-0002 Bit 1: Pulse Count Check for Absolute Encoder

- Cn-0002 bit 1 is valid only when an absolute encoder is used.
- Cn-0002 bit 1 is used to check whether the number of PG pulses (phase A and B) between origin pulses (phase C) match the number of pulses per revolution when an absolute encoder is used.
- This check is disabled when Cn-0002 bit 1 is set to 1.

■ Cn-0002 Bit 6: Software Limit Check by A Reference

- Cn-0002 bit 6 is used to determine whether the software limit check is enabled when a position reference such as POSING or INTERPOLATE or other is input.
- The software limit check is enabled when Cn-0002 bit 6 is set to 1.

■ Cn-0013 Bit 10: MECHATROLINK Communication Check Mask

- Cn-0013 bit 10 is used to cancel the communication check for debugging.
- Normally, set Cn-0013 bit 10 to communication check enabled.
- The communication check can be canceled by setting Cn-0013 bit 10 to 1.

■ Cn-0013 Bit 11: WDT Check Mask

- Cn-0013 bit 11 is used to cancel the WDT check for debugging.
- Normally, set Cn-0013 bit 11 to WDT check enabled
- The WDT check can be canceled by setting Cn-0013 bit 11 to 1.

■ Cn-0014 Bit 1: Zero Point Return Direction

- Set this bit to 0 when zero point return direction is the forward direction (+).
- Set this bit to 1 when zero point return direction is the reverse direction (-).

■ Cn-0014 Bit 2: P-SOT Mask

- Cn-0014 bit 2 is used to set whether the forward software limit check is enabled.
- The forward software limit check is disabled when Cn-0014 bit 2 is set to 1.

■ Cn-0014 Bit 3: N-SOT Mask

- Cn-0014 bit 3 is used to set whether the negative software limit check is enabled.
- The negative software limit check is disabled when Cn-0014 bit 3 is set to 1.

■ **Cn-0014 Bit 9: Brake Operation**

- Selects the SERVOPACK user constant or the BRK_ON/BRK_OFF command to operate the brake reference.
- The brake reference is operated by the SERVOPACK user constant when Cn-0014 bit 9 is set to 1.

■ **Cn-0014 Bit 10: P-OT Signal Logic**

- The P-OT signal logic is reversed when Cn-0014 bit 10 is set to 1. Forward drive is prohibited when the P-OT signal is turned OFF (Signal is CLOSED).

■ **Cn-0014 Bit 11: N-OT Signal Logic**

- The N-OT signal logic is reversed when Cn-0014 bit 11 is set to 1. Reverse drive is prohibited when the N-OT signal is turned OFF (Signal is CLOSED).

■ **Cn-0014 Bit 12: DEC Signal Logic**

- The DEC signal logic is reversed when Cn-0014 bit 12 is set to 1.
- The motor moves at zero point return approach speed 1 when the DEC signal is turned OFF (Signal is OPEN).
- The motor searches for the origin pulse at zero point return approach speed 2 when the DEC signal is turned ON (Signal is CLOSED).

7.2 List of User Constants

The following table shows the numbers, names, factory settings, and other information for the user constants.

IMPORTANT

- Of the user constants listed below, those that are reserved for the system are used internally by the SERVOPACK and cannot as a rule be accessed by the user.
- SERVOPACK behavior cannot be guaranteed if initial values for user constants reserved for the system are changed.
- Encoder and Servomotor factory settings can only be changed once after power is turned ON.
- Do not enter speed or torque values higher than the maximum for the Servomotor.

Constant No.	Name	Size	Units	Range	Factory Settings
Cn-0001	Memory switches 1	2	bit	–	0380H
Cn-0002	Memory switches 2	2	bit	–	0000H
Cn-0003	Load inertia	2	%	0 to 65535	100
Cn-0004	Speed loop gain	2	0.1 Hz	1 to 20000	400
Cn-0005	Speed loop integration time constant	2	0.01 ms	100 to 65535	2000
Cn-0006	Emergency stop torque	2	%	0 to MAX	MAX
Cn-0007	Positioning near detection width	2	Reference units	0 to 10000	10
Cn-0008	Forward torque limit	2	%	0 to MAX	MAX
Cn-0009	Reverse torque limit	2	%	0 to MAX	MAX
Cn-000A	Reserved for system	2	–	–	0000H
Cn-000B	Reserved for system	2	–	–	0000H
Cn-000C	Torque reference mode switch level	2	%	0 to 32767	200
Cn-000D	Reserved for system	2	–	–	0000H
Cn-000E	Acceleration mode switch level	2	0.167 r/s ²	0 to 3000	0
Cn-000F	Error pulses mode switch level	2	Pulse	0 to 10000	0
Cn-0010	Reserved for system	2	–	–	0000H
Cn-0011	Number of encoder pulses	2	P/R	513 to 32767	Capacity
Cn-0012	Time delay from brake reference to Servo OFF	2	10 ms	0 to 50	0
Cn-0013	Memory switches 3	2	bit	–	0000H
Cn-0014	Memory switches 4	2	bit	–	0000H
Cn-0015	Brake timing during motor running (reference output speed)	2	r/min	0 to MAX	100
Cn-0016	Time delay from Servo OFF to brake ON during motor running	2	10 ms	10 to 100	50

Constant No.	Name	Size	Units	Range	Factory Settings
Cn-0017	Torque reference filter time constant	2	μs	0 to 25000	400
Cn-0018	Torque reference filter time constant (secondary)	2	μs	0 to 25000	0
Cn-0019	Reserved for system	2	–	–	0000H
Cn-001A	Position loop gain	2	0.01/s	1 to 50000	4000
Cn-001B	Positioning completed width	2	Reference units	0 to 250	7
Cn-001C	Bias	2	100 reference units/s	0 to MAX	0
Cn-001D	Feed forward compensation	2	%	0 to 100	0
Cn-001E	Position error overflow range	2	Reference units	1 to 65535	65535
Cn-001F	First-step linear acceleration/deceleration constant	2	10000 reference units/s ²	0 to 65535	0
Cn-0020	Second-step linear acceleration/deceleration constant	2	10000 reference units/s ²	0 to 65535	100
Cn-0021	Acceleration/deceleration constant switching speed	2	100 reference units/s	0 to 65535	0
Cn-0022	Zero point return approach speed 1	2	100 reference units/s	0 to 65535	50
Cn-0023	Zero point return approach speed 2	2	100 reference units/s	0 to 65535	5
Cn-0024	Electronic gear ratio B (numerator)	2	–	1 to 32768	4
Cn-0025	Electronic gear ratio A (denominator)	2	–	1 to 32768	1
Cn-0026	Running average time	2	100 μs	0 to 5100	0
Cn-0027	Feed forward reference filter	2	μs	0 to 64000	0
Cn-0028	Final travel distance to return to zero point	4	Reference units	–2147483648 to 2147483647	1000
Cn-002A	Origin width	2	Reference units	0 to 65535	10
Cn-002B	Final travel distance with external positioning	4	Reference units	–2147483648 to 2147483647	100
Cn-002D	Exponential acceleration/deceleration bias	2	500 reference units/s	0 to 32767	0
Cn-002E	Exponential acceleration/deceleration time constant	2	100 μs	0 to 5100	0
Cn-002F	Forward software limit	4	Reference units	–2147483648 to 2147483647	8192 × 99999
Cn-0031	Reverse software limit	4	Reference units	–2147483648 to 2147483647	–8192 × 99999
Cn-0033	Absolute encoder origin offset	4	Reference units	–2147483648 to 2147483647	0
Cn-0035	Speed loop compensation constant	2	–	0 to 100	0
Cn-0036	Reserved for system	2	–	–	0000H

Constant No.	Name	Size	Units	Range	Factory Settings
Cn-0035	Speed loop compensation constant	2	–	0 to 100	0
Cn-0036	Reserved for system	2	–	–	0000H
Cn-0037	Servomotor selection	2	–	0 to 255	Capacity
Cn-0038	Changing PG power supply voltage	2	0.1 mV	52000 to 58000	52500
Cn-0039	Reserved for system	2	–	–	0000H
Cn-003A	Reserved for system	2	–	–	0000H
Cn-003B	Reserved for system	2	–	–	0000H
Cn-003C	Reserved for system	2	–	–	0000H
Cn-003D	Reserved for system	2	–	–	0000H
Cn-003E	Reserved for system	2	–	–	0000H
Cn-003F	Reserved for system	2	–	–	0000H

- Note 1.** Non-volatile parameters are saved on EEPROM and cannot be changed very often. It usually takes about 60 ms to overwrite by 2-byte parameter, and about 120 ms to overwrite by 4-byte parameter, but response of a command will vary somewhat depending on the status of the buffer.
- The factory setting for load inertia is an equivalent inertia of the Servomotor. Since vibrations will occur using the factory setting with a small load inertia, always set the load inertia to around 0 prior to operation.
 - Be sure to use an electronic gear ratio (Cn-0024 and 0025) within a range where $0.01 \leq B(\text{Cn-0024})/A(\text{Cn-0025}) \leq 100$.
 - To avoid possible danger, never change parameters such as motor selection, encoder selection and number of encoder pulses while the Servomotor is running (main circuit ON).
 - Changing parameters like the electronic gear ratio and number of encoder pulses may cause the Servomotor to run at a maximum speed outside the specified Servomotor speed range and may generate an alarm code 04 when power is turned ON. If this happens, check the reference units one more time.
 - Be sure to convert all data to hexadecimal before writing it. Convert b15 (MSB) to b0 (LSB) to hexadecimal in 4-bit groups (b15 to b12, b11 to b8, b7 to b4, b3 to b0) for memory switches 1 to 4. Data sent from SERVOPACKS is read in hexadecimal, and note that □□□□H in the table is a hexadecimal number. The values specified in Cn-0028, 002B and 002F to 0033 have a sign and are 32-bit twos complements when a minus (–) sign is added.
 - The setting value of Cn-0015 must be smaller than the number of motor rotation.

7.3 Memory Switch Bit Details

The following describes each bit of memory switch (bit-type user constant).

7.3.1 Cn-0001: Memory Switches 1

■ Bits b0 to b7

The following table shows details of bits b0 to b7.

Bit	Description	Factory Setting
b0	SV_ON command mask 0: Enable SV_ON/SV_OFF command. 1: Always send SV_ON command (Servo ON)	0
b1	SENS_ON command mask 0: Enable SENS_ON/SENS_OFF command 1: Always send SENS_ON command (Encoder power ON)	0
b2	P-OT mask 0: Enable the P-OT signal. 1: Mask (always disable) P-OT signal	0
b3	N-OT mask 0: Enable N-OT signal. 1: Mask (always disable) N-OT signal	0
b4	–	0
b5	–	0
b6	Stopping method for base block 0: Dynamic brake (DB) stop 1: Coasting to a stop	0
b7	Operation after dynamic brake stop 0: Release dynamic brake. 1: Do not release dynamic brake.	1

Note Never change the factory setting of the bit marked with “–”.

Cn-0001

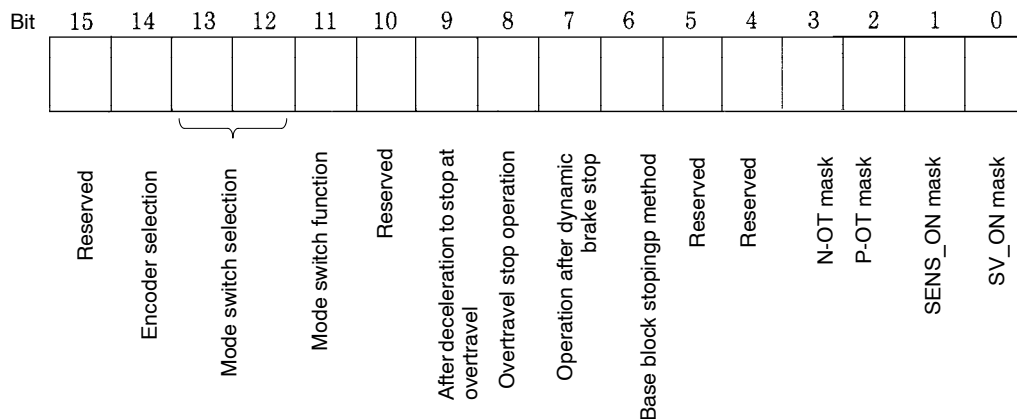

■ Bits b8 to bF

The following table shows details of bits b8 to bF.

Bit	Description	Factory Setting
b8	Overtravel stop method 0: Stopping procedure depends on the setting of bit 6. 1: Decelerate to a stop using emergency stop torque.	1
b9	Operation after deceleration to stop at overtravel 0: Servo turns OFF after deceleration to a stop. 1: Zero clamping after deceleration to a stop (Position clamping).	1
bA	–	0
bB	Mode switch function 0: Use the mode switch function (depending on bits 12 and 13). 1: Disable the mode switch function.	0
bC	00: Mode switch selection (use internal torque reference) 01: None(Do not use this setting)	0
bD	10: Mode switch selection (use acceleration) 11: Mode switch selection (use error pulse)	0
bE	Encoder selection 0: Incremental encoder 1: Absolute encoder	0
bF	–	0

Note Never change the factory setting of the bit marked with“–”.

7.3.2 Cn-0002: Memory Switches 2

The following table shows details of Cn-0002: Memory switch 2 bits.

Bit	Description	Factory Setting
b0	Motor rotation direction 0: The forward direction is counterclockwise direction. 1: The forward direction is clockwise direction (reverse rotation mode).	0
b1	Zero point error detection mask 0: Detect zero point error (only with an absolute encoder) 1: Do not detect zero point errors.	0
b2	–	0
b3	–	0
b4	–	0
b5	–	0
b6	Software limit check by a reference position 0: Do not check. 1: Check.	0
b7	–	0
b8	–	0
b9	–	0
bA	–	0
bB	–	0
bC	–	0
bD	–	0
bE	–	0
bF	–	0

Note Never change the factory settings of the bits marked with “–”.

Cn-0002

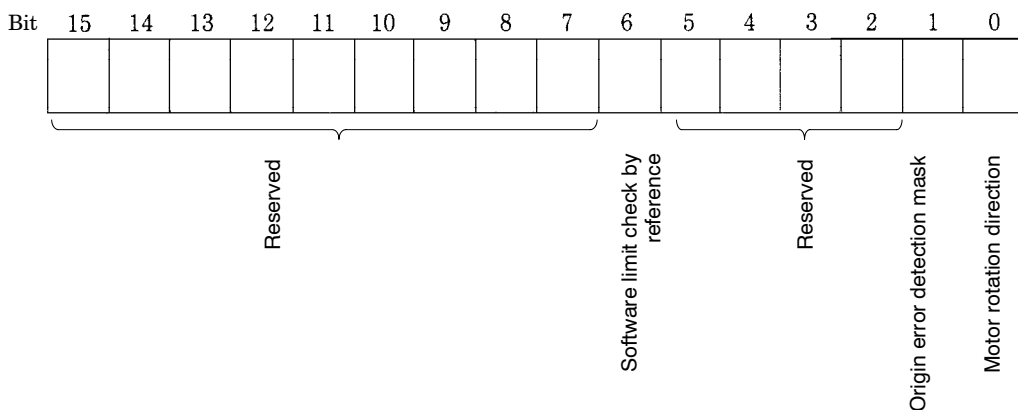

7.3.3 Cn-0013: Memory Switches 3

The following table shows details of Cn-0013: Memory switches 3 bits.

Bit	Description	Factory Setting
b0	–	0
b1	–	0
b2	–	0
b3	–	0
b4	–	0
b5	–	0
b6	–	0
b7	–	0
b8	–	0
b9	–	0
bA	MECHATROLINK Communication Check Mask (for Debugging) 0: Perform communication check 1: Communication check masked	0
bB	WDT Check Mask (for Debugging) 0: Check WDT 1: Mask WDT	0
bC	–	0
bD	–	0
bE	–	0
bF	–	0

Note Never change the factory settings of the bits marked with “–”.

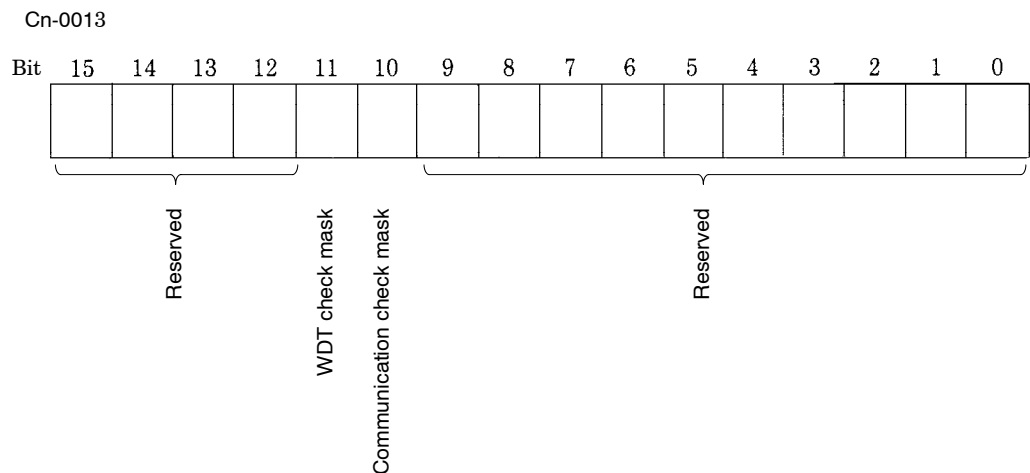

7.3.4 Cn-0014: Memory Switches 4

■ Bit b0 to b7

The following table shows details of bits b0 to b7.

Bit	Description	Factory Setting
b0	–	0
b1	Zero point return direction 0: Forward direction 1: Reverse direction	0
b2	P-SOT mask 0: Enable forward software limit. 1: Mask (always disable) forward software limit.	0
b3	N-SOT mask 0: Enable reverse software limit. 1: Mask (always disable) reverse software limit.	0
b4	–	0
b5	–	0
b6	–	0
b7	–	0

Note Never change the factory settings of the bits marked with “–”.

■ Bit b8 to bF

The following table shows details of bits b8 to bF.

Bit	Description	Factory Setting
b8	–	0
b9	Brake operation 0: Operate with the BRK_ON/BRK_OFF command. 1: Operate from the SERVOPACK (BRK_ON/BRK_OFF command disabled)	0
bA	P-OT signal 0: Positive logic 1: Negative logic	0
bB	N-OT signal 0: Positive logic 1: Negative logic	0
bC	DEC signal 0: Positive logic 1: Negative logic	0
bD	–	0
bE	–	0
bF	–	0

Note Never change the factory settings of the bits marked with “–”.

Cn-0014

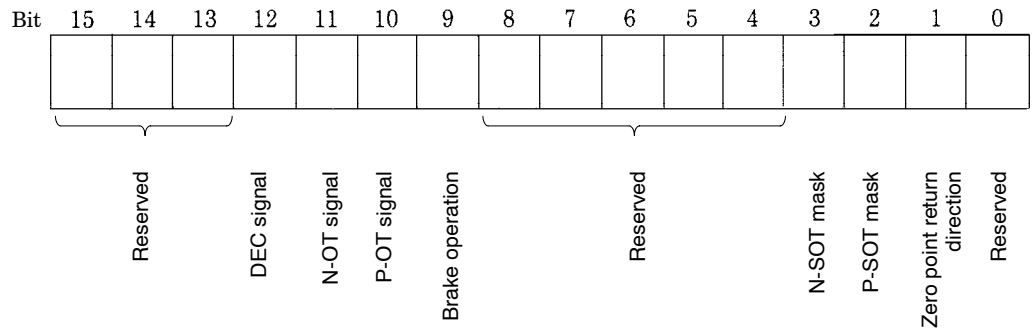

7.4 Limits to User Constant Changes

The only user constants that can be changed during motor running are those listed below. Never change the other user constants during motor running.

Number	Name
Cn-0004	Speed loop gain
Cn-0005	Speed loop integration time constant
Cn-0008	Positive torque limit
Cn-0009	Negative torque limit
Cn-0017	Torque reference filter time constant
Cn-0018	Torque reference filter time constant (secondary)
Cn-001A	Position loop gain
Cn-001C	Bias
Cn-001D	Feed forward compensation

7.5 Procedure for Transferring User Constants

The procedure for changing (transferring) user constants (parameters) after power is turned ON is to transfer Servomotor selection, encoder selection (encoder type and number of pulses), electronic gear ratio, and other user constants in this order only. Randomly transferring user constants will cause a user constant setting alarm and parameters may not be received.

Motor selection, encoder selection and electronic gear ratio parameters can be changed only once after power is turned ON and this must be done prior to executing the SENS_ON command and the motor running.

Table 7.1 Cn-0037 Servomotor Selection List

Group	SERVOPACK	Servomotor	Servomotor No. (Cn-0037 Setting)
05	SGDB-05AN	SGMG-03A□B	ABH
		SGMG-05A□A	8EH
		SGMP-04A	7EH
		SGM-04A	6AH
10	SGDB-10AN	SGMG-06A□B	ACH
		SGMG-09A□A	8FH
		SGMG-09A□B	ADH
		SGMS-10A□A	A3H
		SGMP-08A	7FH
		SGM-08A	6BH
15	SGDB-15AN	SGMG-13A□A	90H
		SGMG-12A□B	AFH
		SGMS-15A□A	A4H
		SGMP-15A	80H
20	SGDB-20AN	SGMG-20A□A	91H
		SGMG-20A□B	AFH
		SGMS-20A□A	A5H
30	SGDB-30AN	SGMG-30A□A	92H
		SGMG-30A□B	B0H
		SGMS-30A□A	A6H
		SGMD-22A□A	9BH
50	SGDB-50AN	SGMG-44A□A	93H
		SGMG-44A□B	B1H
		SGMS-40A□A	A7H
		SGMD-32A□A	9CH
		SGMS-50A□A	A8H
		SGMD-40A□A	9DH

Group	SERVOPACK	Servomotor	Servomotor No. (Cn-0037 Setting)
60	SGDB-60AN	SGMG-55A□A	94H
		SGMG-60A□B	B2H
75	SGDB-75AN	SGMG-75A□A	95H
1A	SGDB-1AAN	SGMG-1AA□A	8CH
1E	SGDB-1EAN	SGMG-1EA□A	96H

Note The setting at user constant Cn-0037 can be changed as long as the applicable Servomotor is within the same group.

8

Installation and Wiring

This chapter describes procedures for checking to be performed when the Servomotors and SERVOPACKs are delivered as well as installation and wiring specifications.

8.1	Checking on Delivery	8 -2
8.2	Installation	8 -3
8.2.1	Installing the Servomotor	8 -3
8.2.2	Installing the SERVOPACK	8 -4
8.3	Wiring Specifications	8 -7
8.3.1	Rated Current and Cable Specifications	8 -7
8.3.2	Wiring Instructions	8 -9
8.3.3	Power Loss	8 -11

8.1 Checking on Delivery

When Σ -Series products are delivered, check the following items:

Check Items	Remarks
Check if the delivered products are the ones you ordered.	Check the model numbers marked on the nameplates of Servomotor and SERVOPACK.
Check for damage.	Check the overall appearance, and check for damage or scratches resulting from transportation.
Check if the motor shaft rotates smoothly.	If the motor shaft can be smoothly turned by hand, it is normal. If the motor has a brake, however, it cannot be turned manually.
Check loose screws.	Check for looseness by using a screwdriver as necessary.

If any of the above items are faulty or incorrect, contact the dealer from which you purchased the products or your nearest sales representative. Be sure to confirm that there are no loose screws, breakage in lead wires, or damage in insulation.

8.2 Installation

8.2.1 Installing the Servomotor

The Servomotor can be installed either horizontally or vertically. If the Servomotor is installed incorrectly or in an inappropriate location, the service life will be shortened or unexpected problems will occur. To prevent this, always observe the installation instructions provided below.

⚠ CAUTION Do not connect the Servomotor directly to a commercial power supply. Doing so will damage the motor.

The Servomotor will not operate unless connected to the proper SERVOPACK.

■ Before Installation

Note Anticorrosive paint is coated on the edge of the motor shaft to prevent corrosion during storage. Before installation, clean off the anticorrosive paint thoroughly using a cloth moistened with thinner. Avoid getting thinner on other parts of the Servomotor when cleaning the shaft.

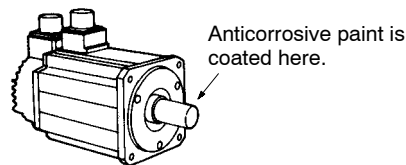

Figure 8.1 AC Servomotor

■ Environment Condition

Use the Servomotor in the following environment:

- Temperature range: -20 to 40°C
- Relative humidity of 20% to 80% (with no condensation)
- Storage temperature: -20 to 60°C

■ Installation Site

The Servomotors are designed for indoor use. Install Servomotor in an environment which meets the following conditions:

- Free from corrosive or explosive gases
- Well-ventilated and free from dust and moisture
- Ambient temperature of 0 to 40°C
- Sufficient access for each inspection and cleaning

If the Servomotor is used in a location subject to water or oil mist, install a shield or cover over the Servomotor.

■ **Alignment**

Align the shaft of the Servomotor with that of the equipment to be controlled. When connecting couplings, be careful not to apply any impact to the shaft or excessive force on bearings. Install the Servomotor so that alignment accuracy falls within the range shown below. If the shafts are not aligned properly, vibration will occur, resulting in damage to the bearings.

Measure this distance at four different positions on the circumference. The difference between the maximum and minimum measurements must be 0.03 mm (0.0012 in) or less. (Turn together with couplings.)

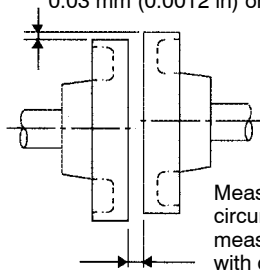

Measure this distance at four different positions on the circumference. The difference between the maximum and minimum measurements must be 0.03 mm (0.0012 in) or less. (Turn together with couplings.)

Figure 8.2 Alignment

■ **Allowable Bearing Load**

Do not apply any excessive thrust load or radial load to the AC Servomotor. When installing gears, couplings, pulleys, etc., be careful not to apply any impact to the shaft or excessive force on bearings. Mechanical shock to the shaft end must be less than 490m/s^2 (1607.61 ft/s^2 50 G)

Design the mechanical system so that thrust load and radial load applied to the servomotor shaft end during operation falls within the range shown in *Table 3.1*.

8.2.2 Installing the SERVOPACK

8

Σ -Series SGDB SERVOPACKS are base-mounted servo controllers.

Install the SERVOPACK according to the following instructions, since faulty installation may cause malfunction.

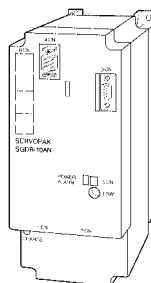

SGDB-□□AN SERVOPACK

■ Installation Site

Site	Precautions
When installed in a control panel	Depending on the size of the panel, the temperature inside the control panel may become higher than the ambient temperature due to heat generated by internal devices. Design the control panel size, unit layout, and cooling method so that the temperature around the SERVOPACK does not exceed 55°C.
When installed near a heating unit	Suppress radiation heat from the heating unit and temperature rise caused by convection so that the temperature around the SERVOPACK does not exceed 55°C.
When installed near a source of vibration	Install a vibration isolator underneath the SERVOPACK to prevent it from receiving vibration.
When installed in a place subject to corrosive gases	Corrosive gases do not immediately affect the SERVOPACK but will eventually cause magnetic contactors or relays in the reference circuits or main circuits to malfunction. Take appropriate action to prevent corrosive gases.
Other locations	Avoid installation in hot or humid places, or where excessive dust or iron powder is present in the air.

■ Orientation

Install the SERVOPACK perpendicular to the wall as shown in the figure.

The SERVOPACK must be orientated as shown in the figure because it is designed to be cooled by natural convection.

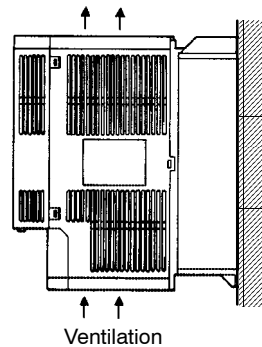

Figure 8.3 Installation Orientation

Mounting Holes

Firmly secure the SERVOPACK through the three or four mounting holes provided.

■ Installation of Multiple SERVOPACKS

When installing multiple SERVOPACKS side by side in a control panel, provide at least 10 mm (0.39 in) space between them and at least 50 mm (1.97 in) space above and below them as shown in the figure above and observe the following installation conditions:

Environmental Conditions

- Ambient temperature for SERVOPACKS: 0 to 55°C
- Humidity: 90% RH or less
- Vibration: 0.5G (4.9 m/s²) (16.08 ft/s²)
- Condensation and freezing: None
- Ambient temperature (or in-panel temperature) to ensure long-term reliability: 45°C or less

Installation Method

- Install the SERVOPACK perpendicular to the wall so that the front panel faces outward (MECHATROLINK communication connector mounting surface).
- Provide sufficient space around each SERVOPACK to allow for cooling by fan or natural convection.
- When installing SERVOPACKS side by side, install cooling fans above the SERVOPACKS to prevent the temperature around each SERVOPACK from increasing excessively and also to maintain an even temperature inside the control panel.

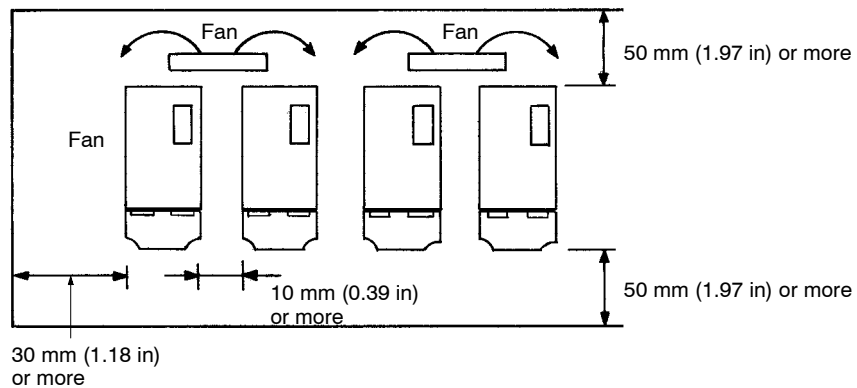

Figure 8.4 Installation Example

8.3 Wiring Specifications

8.3.1 Rated Current and Cable Specifications

The rated current of the SERVOPACK external terminals and cable size are listed in *Tables 8.1* and *8.2*. The cable specifications and sizes must be selected according to the operating environment and current capacity. The cable specifications in these tables were selected under conditions of three cables per bundle at 40° C ambient temperature, with the rated current flowing. *Table 8.3* lists the cable types.

Table 8.1 Rated Currents of SGDB SERVOPACK External Terminals



External Terminal Name		Model Code	Rated Current A (rms) (Effective Value)									
			SGDB -05AN	SGDB -10AN	SGDB -15AN	SGDB -20AN	SGDB -30AN	SGDB -50AN	SGDB -60AN	SGDB -75AN	SGDB -1AAN	SGDB -1EAN
Online Terminals	Main Circuit Power Input Terminals	R, S, T	5.5	10.0	12.5	20.0	25.0	32.5	62.5	75.0	95.0	150
	Motor Connection Terminals	U, V, W	3.8	7.6	11.6	18.5	24.8	32.9	46.9	54.7	58.6	78.0
	Regenerative Resistor Unit Connection Terminals	P1, B	–	–	–	–	–	–	5.4	10.6		
	Control Power Input Terminals	r, t	0.5									
Offline Terminals	Control I/O Signal Connector	1CN	100 mA DC max.									
	PG Signal Connector	2CN	100 mA DC max. (500 mA for the power line)									
	Ground Terminal		–									

Table 8.2 Wire Size Examples

External Terminal Name		Model Code	Cable Size [mm ² (in ²)]									
			SGDB -05AN	SGDB -10AN	SGDB -15AN	SGDB -20AN	SGDB -30AN	SGDB -50AN	SGDB -60AN	SGDB -75AN	SGDB -1AAN	SGDB -1EAN
Online Terminals	Main Circuit Power Input Terminals	R, S, T	HIV 1.25 (0.002) min.	HIV 2.0 (0.003) min.	HIV 3.5 (0.005) min.		HIV 3.5 (0.005) min.	HIV 5.5 (0.009) min.	HIV 8 (0.012) min.	HIV 14 (0.022) min.	HIV 22 (0.034) min.	
	Motor Connection Terminals	U, V, W	HIV 1.25 (0.002) min.	HIV 3.5 (0.005) min.			HIV 5.5 (0.009) min.	HIV 8 (0.012) min.	HIV 14 (0.022) min.		HIV 22 (0.034) min.	
	Regenerative Resistor Unit Connection Terminals	P1, B	-	-	-	-	-	-	HIV8 min.	HIV14 min.		
	Control Power Input Terminals	r, t	HIV 1.25 (0.002) min.									
Offline Terminals	Control I/O Signal Connector	1CN	Use twisted-pair wires or shielded twisted-pair wires. Conductor: 0.12 mm ² (0.0002 in ²) or more, stranded tinned annealed copper wire.									
	PG Signal Connector	2CN	Finished cable size: 16 mm (0.63 in) dia. max. for 1CN and 11 mm (0.43 in) dia. max. for 2CN									
	Ground Terminal		HIV 2.0 (0.003) min.									

- Note 1.** Cable selection conditions: three cables per bundle at 40 °C ambient temperature with the rated current flowing.
2. Use cable with 600 V min. withstand voltage for main circuits.
 3. Consider allowable current reduction ratio if cables are bundled in PVC or metal ducts.
 4. Use temperature-resistant cable under high ambient or panel temperatures where normal vinyl cables rapidly deteriorate.

Table 8.3 Cable Types

Cable Type		Conductor Allowable Temperature °C
Symbol	Name	
PVC	Normal vinyl cable	-
IV	600 V vinyl cable	60
HIV	Temperature-resistant vinyl cable	75

- Note 1.** Use cable with 600 V min. withstand voltage for main circuits.
2. Consider allowable current reduction ratio if cables are bundled in PVC or metal ducts.
 3. Use temperature-resistant cable under high ambient or in-panel temperatures where normal vinyl cables rapidly deteriorate.

The following table shows specifications of cables used for SERVOPACK connectors 1CN and 2CN.

Control I/O Signal Connector	1CN	Cable	Use twisted-pair wires or shielded twisted-pair wires.
		Applicable Cable	AWG24,26,28,30
		Finished Cable Dimensions	φ16.0 mm (φ0.63 in.) max.
PG Signal Connector	2CN	Cable	Use Yaskawa cable. Use shielded twisted-pair cable if a Yaskawa cable is not used. See 8.3.1 “ <i>Rated Current and Cable Specification</i> ” for details.
		Applicable Cable	Applicable cable sizes: AWG24, 26, 28, 30 Use AWG22 [(0.32 mm ²) (0.0005 in ²)] for encoder power supply and FG lines. Use AWG26 [(0.12 mm ²) (0.0002 in ²)] for other signals. These connections permit wiring distances up to 20 m (65.6 ft.).
		Finished Cable Dimensions	φ11.6 mm (φ0.46 in.) max.

Note Cable selection conditions: three cables per bundle at 40 °C ambient temperature with the rated current flowing.

8.3.2 Wiring Instructions

To ensure safe and stable operation, always refer to the following wiring instructions.

- For signal lines and PG feedback lines, use twisted-pair wires and multicore shielded twisted-pair wires (Yaskawa Drawing No. B9400064 or DE8400093).
The maximum allowable wiring length is as follows: 50 m (164.04 ft) for I/O lines (at 24 V power supply), 20 m (65.62ft) for PG feedback lines, and 50 m (164.04 ft) for MECHATRO-LINK communication line. Cut off the excess portion of the cable to minimize the cable length.
- For a ground wire, use as thick a cable as possible.
At least grounding to 100 Ω or less is recommended. Always ground to one point only. If the motor is insulated from the machine, ground the motor directly.
- To prevent malfunction due to noise, take the following actions:
 - Position the input reference device and noise filter as close to the SERVOPACK as possible.
 - Always install a surge absorber circuit in the relay, solenoid and magnetic contactor coils.
 - The distance between a power line (such as a power supply line or motor cable) and a signal line must be at least 30 cm (12 in). Do not put the power and signal lines in the same duct or bundle them together.
 - Do not share the power supply with an electric welder or electrical discharge machine. When the SERVOPACK is placed near a high-frequency oscillator, install a noise filter on the input side of the power supply line.
 - The SERVOPACK uses high-speed switching elements, which may cause noise on signal lines. To prevent this, always take the above actions.

- **Prevention of Radio Frequency Interference (RFI)**
Since the SERVOPACKS are designed for industrial use, no measures are provided against radio frequency interference. Use a noise filter in the power input line when using the SERVOPACKS near residential areas or where they are prone to radio frequency interference.
- **Do not bend or apply tension to cables.**
Since the conductor of a signal cable is very thin [0.1 to 0.3 mm² (0.0002 to 0.0005 in²)], handle it with adequate care.

8.3.3 Power Loss

Table 8.4 shows the power loss of the SERVOPACKS.

Table 8.4 Power Loss at Rated Output

SERVOPACK Model	Output Current (rms) (A)	Main Circuit Power Loss (W)	Regenerative Resistor Power Loss (W)	Control Circuit Power Loss (W)	Total Power Loss (W)
SGDB-05AN	3.8	27	30	20	77
SGDB-10AN	7.6	55			105
SGDB-15AN	11.6	80			130
SGDB-20AN	18.5	120			170
SGDB-30AN	24.8	170		22	222
SGDB-50AN	28.2	260	60	24	344
SGDB-60AN	46.9	290	-	27	317
SGDB-75AN	54.7	330		357	
SGDB-1AAN	58.6	360		30	390
SGDB-1EAN	78.0	49.0		30	520

- Note 1.** The power loss of Regenerative Resistors is the permissible power loss. If the permissible power loss is exceeded, remove the built-in Regenerative Resistor from the SERVOPACK and reinstall an external resistor. A SERVOPACK with an external Regenerative Resistor is a nonstandard model ("Y8" is added to the end of the model number of a standard model.) For nonstandard SERVOPACK models, contact your nearest Yaskawa sales representative.
- 2.** For the SGDB-60AN to SGDB-1AAN models, the Regenerative Resistors are installed separately. The regenerative resistor unit made available by Yaskawa is shown in 5.6.3 "Regenerative Resistor Unit". The permissible power loss of the regenerative resistor (JUSP-RA04) for SGDB-60AN is 180 W, and that of the Regenerative Resistor (JUSP-RA05) for SGDB-75AN and SGDB-1AAN is 350 W.

9

Servodrives Dimensional Drawings

This chapter shows dimensional drawings of the Servomotors, SERVOPACKS, and peripheral devices.

9.1 AC Servomotors	9 -3
9.1.1 SGMG-□□A□A Servomotors	9 -3
9.1.2 SGMG-□□A□B Servomotors	9 -16
9.1.3 SGMS-□□A Servomotors	9 -26
9.1.4 SGMD-□□A Servomotors	9 -34
9.1.5 SGMP-15A Servomotor	9 -38
9.1.6 List of Encoder and Servomotor End Connectors	9 -46
9.2 SERVOPACKS	9 -53
9.2.1 SGDB-05AN□ to 15AN□ SERVOPACKS (0.5 to 1.5 kW)	9 -53
9.2.2 SGDB-20AN□ to 30AN□ SERVOPACKS (2.0 to 3.0 kW)	9 -54
9.2.3 SGDB-50AN□ SERVOPACKS (5.0 kW)	9 -55
9.2.4 SGDB-60AN□ to 75AN□ SERVOPACKS (6.0 to 7.5 kW)	9 -56
9.2.5 SGDB-1AAN, 1EAN SERVOPACKS (11, 15 kW) .	9 -57
9.2.6 SGDB-05AN□-P to 15AN□-P SERVOPACKS . . .	9 -58
9.2.7 SGDB-20AN□-P to 30AN□-P SERVOPACKS . . .	9 -59
9.2.8 SGDB-50AN□-P SERVOPACK	9 -60
9.2.9 SGDB-60AN□ to 75AN□-P SERVOPACKS	9 -61
9.2.10 SGDB-1AAN-P, 1EAN-P SERVOPACKS	9 -62

9.3 Cables	9 -64
9.3.1 Encoder Cables	9 -64
9.3.2 Servomotor Cables	9 -73
9.3.3 I/O Signal Cables (1CN)	9 -74
9.3.4 MECHATROLINK Communication Cables (4CN) .	9 -74
9.4 Connectors	9 -75
9.4.1 SGMG, SGMS and SGMD Servomotors Connections	9 -75
9.4.2 SGM and SGMP Servomotors Connections	9 -87
9.4.3 SGMP-15A Servomotor Connectors	9 -89
9.4.4 SERVOPACK Encoder Connectors	9 -90
9.4.5 1CN, 2CN Connector for SERVOPACK	9 -92
9.4.6 4CN Connector for SERVOPACK	9 -93
9.5 Noise Filters	9 -94
9.5.1 Dimensional Diagram	9 -94
9.6 Peripheral Devices	9 -96
9.6.1 Connector Terminal Block Converter Unit	9 -96
9.6.2 Brake Power Supply	9 -96
9.6.3 Molded-case Circuit Breaker	9 -98
9.6.4 Magnetic Contactor	9 -98
9.6.5 Surge Suppressor	9 -100
9.6.6 Regenerative Resistor Unit	9 -100
9.6.7 Analog Monitor Cable	9 -101

9.1 AC Servomotors

9.1.1 SGMG-□□A□A Servomotors

■ Servomotors with 8192-P/R Incremental Encoders

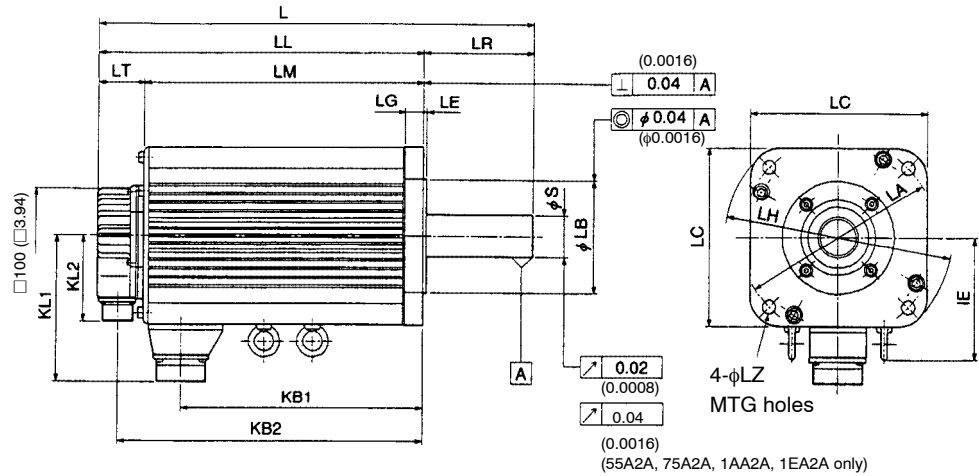

Shaft Extension
(SGMG-05A2A to 13A2A, 1AA2A)

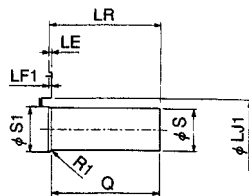

Shaft Extension
(SGMG-20A2A to 75A2A)

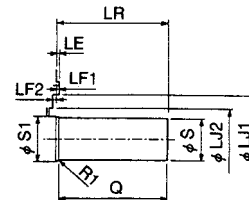

Servodrives Dimensional Drawings

9.1.1 SGMG-□□A□A Servomotors

[mm (in)]

Model SGMG-	L	LL	LM	LR	LT	KB1	KB2	IE	KL1	KL2
05A2A	196 (7.72)	138 (5.43)	92 (3.62)	58 (2.28)	46 (1.81)	65 (2.56)	117 (4.61)	—	109 (4.29)	88 (3.46)
09A2A	219 (8.62)	161 (6.34)	115 (4.53)	58 (2.28)	46 (1.81)	88 (3.46)	140 (5.51)	—	109 (4.29)	88 (3.46)
13A2A	243 (9.57)	185 (7.28)	139 (5.47)	58 (2.28)	46 (1.81)	112 (4.41)	164 (6.46)	—	109 (4.29)	88 (3.46)
20A2A	245 (9.65)	166 (6.54)	119 (4.69)	79 (3.11)	47 (1.85)	89 (3.50)	145 (5.71)	—	140 (5.51)	88 (3.46)
30A2A	271 (10.67)	192 (7.56)	145 (5.71)	79 (3.11)	47 (1.85)	115 (4.53)	171 (6.73)	—	140 (5.51)	88 (3.46)
44A2A	305 (12.01)	226 (8.90)	179 (7.05)	79 (3.11)	47 (1.85)	149 (5.87)	205 (8.07)	—	140 (5.51)	88 (3.46)
55A2A	373 (14.69)	260 (10.24)	213 (8.39)	113 (4.45)	47 (1.85)	174 (6.85)	239 (9.41)	125 (4.92)	150 (5.91)	88 (3.46)
75A2A	447 (17.60)	334 (13.15)	287 (11.30)	113 (4.45)	47 (1.85)	248 (9.76)	313 (12.32)	125 (4.92)	150 (5.91)	88 (3.46)
1AA2A	454 (17.87)	338 (13.31)	291 (11.46)	116 (4.57)	47 (1.85)	251 (9.88)	317 (12.48)	142 (5.59)	168 (6.61)	88 (3.46)
1EA2A	573 (22.56)	457 (17.99)	388 (15.28)	116 (4.57)	69 (2.72)	343 (13.50)	435 (17.13)	142 (5.59)	168 (6.61)	88 (3.46)

Model SGMG-	Flange Dimensions [mm (in)]											Shaft End Dimensions [mm (in)]			Approx. Mass [kg (lb)]
	LA	LB	LC	LE	LF1	LF2	LG	LH	LJ1	LJ2	LZ	S	S1	Q	
05A2A	145 (5.71)	$110 \begin{matrix} 0 \\ -0.035 \\ 0 \\ (4.33 - 0.0014) \end{matrix}$	130 (5.12)	6 (0.24)	6 (0.24)	-	12 (0.47)	165 (6.50)	45 (1.77)	-	9 (0.35)	$19 \begin{matrix} 0 \\ -0.013 \\ 0 \\ (0.75 - 0.0005) \end{matrix}$	30 (1.18)	40 (1.57)	5.5 (12.1)
09A2A	145 (5.71)	$110 \begin{matrix} 0 \\ -0.035 \\ 0 \\ (4.33 - 0.0014) \end{matrix}$	130 (5.12)	6 (0.24)	6 (0.24)	-	12 (0.47)	165 (6.50)	45 (1.77)	-	9 (0.35)	$19 \begin{matrix} 0 \\ -0.013 \\ 0 \\ (0.75 - 0.0005) \end{matrix}$	30 (1.18)	40 (1.57)	7.6 (16.8)
13A2A	145 (5.71)	$110 \begin{matrix} 0 \\ -0.035 \\ 0 \\ (4.33 - 0.0014) \end{matrix}$	130 (5.12)	6 (0.24)	6 (0.24)	-	12 (0.47)	165 (6.50)	45 (1.77)	-	9 (0.35)	$22 \begin{matrix} 0 \\ -0.013 \\ 0 \\ (0.87 - 0.0005) \end{matrix}$	30 (1.18)	40 (1.57)	9.6 (21.2)
20A2A	200 (7.87)	$114.3 \begin{matrix} 0 \\ -0.025 \\ 0 \\ (4.50 - 0.0010) \end{matrix}$	180 (7.09)	3.2 (0.13)	3 (0.12)	0.5 (0.020)	18 (0.71)	230 (9.06)	76 (2.99)	62 (2.44)	13.5 (0.53)	$35 \begin{matrix} +0.01 \\ 0 \\ +0.0004 \\ (1.38 \quad 0) \end{matrix}$	45 (1.77)	76 (2.99)	14 (30.9)
30A2A	200 (7.87)	$114.3 \begin{matrix} 0 \\ -0.025 \\ 0 \\ (4.50 - 0.0010) \end{matrix}$	180 (7.09)	3.2 (0.13)	3 (0.12)	0.5 (0.020)	18 (0.71)	230 (9.06)	76 (2.99)	62 (2.44)	13.5 (0.53)	$35 \begin{matrix} +0.01 \\ 0 \\ +0.0004 \\ (1.38 \quad 0) \end{matrix}$	45 (1.77)	76 (2.99)	18 (39.7)
44A2A	200 (7.87)	$114.3 \begin{matrix} 0 \\ -0.025 \\ 0 \\ (4.50 - 0.0010) \end{matrix}$	180 (7.09)	3.2 (0.13)	3 (0.12)	0.5 (0.020)	18 (0.71)	230 (9.06)	76 (2.99)	62 (2.44)	13.5 (0.53)	$35 \begin{matrix} +0.01 \\ 0 \\ +0.0004 \\ (1.38 \quad 0) \end{matrix}$	45 (1.77)	76 (2.99)	23 (50.7)
55A2A	200 (7.87)	$114.3 \begin{matrix} 0 \\ -0.025 \\ 0 \\ (4.50 - 0.0010) \end{matrix}$	180 (7.09)	3.2 (0.13)	3 (0.12)	0.5 (0.020)	18 (0.71)	230 (9.06)	76 (2.99)	62 (2.44)	13.5 (0.53)	$42 \begin{matrix} 0 \\ -0.016 \\ 0 \\ (1.65 - 0.0006) \end{matrix}$	45 (1.77)	110 (4.33)	30 (66.1)
75A2A	200 (7.87)	$114.3 \begin{matrix} 0 \\ -0.025 \\ 0 \\ (4.50 - 0.0010) \end{matrix}$	180 (7.09)	3.2 (0.13)	3 (0.12)	0.5 (0.020)	18 (0.71)	230 (9.06)	76 (2.99)	62 (2.44)	13.5 (0.53)	$42 \begin{matrix} 0 \\ -0.016 \\ 0 \\ (1.65 - 0.0006) \end{matrix}$	45 (1.77)	110 (4.33)	40 (88.2)
1AA2A	235 (9.25)	$200 \begin{matrix} 0 \\ -0.046 \\ 0 \\ (7.87 - 0.0018) \end{matrix}$	220 (8.66)	4 (0.16)	4 (0.16)	-	18 (0.71)	270 (10.63)	62 (2.44)	-	13.5 (0.53)	$42 \begin{matrix} 0 \\ -0.016 \\ 0 \\ (1.65 - 0.0006) \end{matrix}$	45 (1.77)	110 (4.33)	57.5 (127)
1EA2A	235 (9.25)	$200 \begin{matrix} 0 \\ -0.046 \\ 0 \\ (7.87 - 0.0018) \end{matrix}$	220 (8.66)	4 (0.16)	4 (0.16)	-	20 (0.79)	270 (10.63)	85 (3.35)	-	13.5 (0.53)	$55 \begin{matrix} +0.030 \\ -0.011 \\ 0 \\ (2.17 - 0.0004) \end{matrix}$	65 (2.56)	110 (4.33)	80 (3.15)

Note 1. The Encoder uses 8192-P/R incremental encoder.

2. Eyebolts are not provided with the SGMG-05A to 44A2A Servomotor.

Connector Wiring on Encoder End

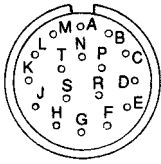

Receptacle: MS3102A20-29

Plug (To be prepared by customer) (L type): MS3108B20-29S or (Straight type) MS3106B20-29S

Cable Clamp: (To be prepared by customer) MS3057-12A

A	A Channel Output	K	-
B	\bar{A} Channel Output	L	-
C	B Channel Output	M	-
D	\bar{B} Channel Output	N	-
E	C Channel Output	P	-
F	\bar{C} Channel Output	R	-
G	0 V	S	-
H	+5 VDC	T	-
J	FG (Frame Ground)		

Note 1. Terminals K to T are not used.

2. Receptacle, plug and cable clamp are common regardless of motor capacity.

Connector Wiring on Servomotor End

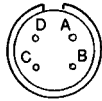

A	Phase U
B	Phase V
C	Phase W
D	Ground terminal

■ Servomotors with 8192 P/R Incremental Encoders and Brakes

0.5 to 4.4 kW Servomotors

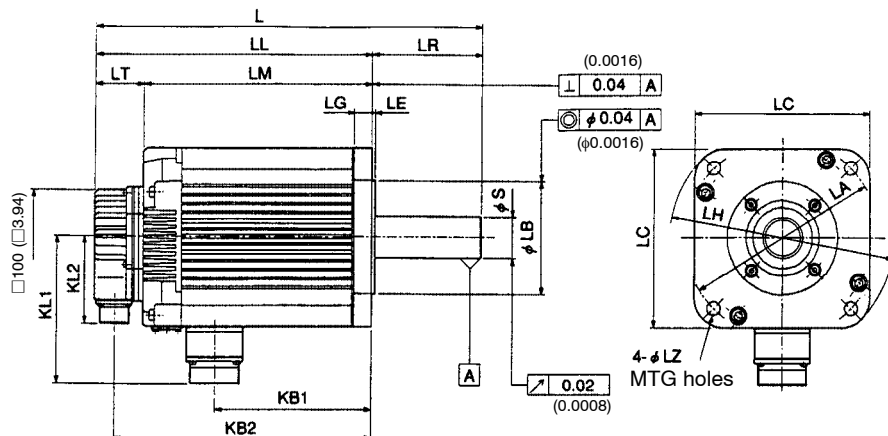

Shaft Extension
(SGMG-05A2AAB to 13A2AAB)

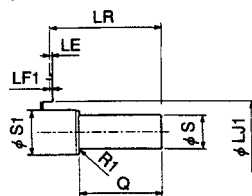

Shaft Extension
(SGMG-20A2AAB to 44A2AAB)

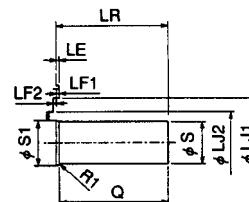

[mm (in)]

Model SGMG-	L	LL	LM	LR	LT	KB1	KB2	KL1	KL2
05A2AAB	234 (9.21)	176 (6.93)	129 (5.08)	58 (2.28)	47 (1.85)	56 (2.20)	155 (6.10)	120 (4.72)	88 (3.46)
09A2AAB	257 (10.12)	199 (7.83)	152 (5.98)	58 (2.28)	47 (1.85)	79 (3.11)	178 (7.01)	120 (4.72)	88 (3.46)
13A2AAB	281 (11.06)	223 (8.78)	176 (6.93)	58 (2.28)	47 (1.85)	103 (4.06)	202 (7.95)	120 (4.72)	88 (3.46)
20A2AAB	296 (11.65)	217 (8.54)	170 (6.69)	79 (3.11)	47 (1.85)	79 (3.11)	196 (7.72)	146 (5.75)	88 (3.46)
30A2AAB	322 (12.68)	243 (9.57)	196 (7.72)	79 (3.11)	47 (1.85)	105 (4.13)	222 (8.74)	146 (5.75)	88 (3.46)
44A2AAB	356 (14.02)	277 (10.91)	230 (9.06)	79 (3.11)	47 (1.85)	139 (5.47)	256 (10.08)	146 (5.75)	88 (3.46)

Model SGMG-	Flange Dimensions [mm (in)]											Shaft End Dimensions [mm (in)]			Approx. Mass [kg (lb)]
	LA	LB	LC	LE	LF1	LF2	LG	LH	LJ1	LJ2	LZ	S	S1	Q	
05A2AAB	145 (5.71)	$110 \begin{matrix} 0 \\ -0.035 \\ 0 \\ (4.33 - 0.0014) \end{matrix}$	130 (5.12)	6 (0.24)	6 (0.24)	-	12 (0.47)	165 (6.50)	45 (1.77)	-	9 (0.35)	$19 \begin{matrix} 0 \\ -0.013 \\ 0 \\ (0.75 - 0.0005) \end{matrix}$	30 (1.18)	40 (1.57)	7.5 (16.5)
09A2AAB	145 (5.71)	$110 \begin{matrix} 0 \\ -0.035 \\ 0 \\ (4.33 - 0.0014) \end{matrix}$	130 (5.12)	6 (0.24)	6 (0.24)	-	12 (0.47)	165 (6.50)	45 (1.77)	-	9 (0.35)	$19 \begin{matrix} 0 \\ -0.013 \\ 0 \\ (0.75 - 0.0005) \end{matrix}$	30 (1.18)	40 (1.57)	9.6 (21.2)
13A2AAB	145 (5.71)	$110 \begin{matrix} 0 \\ -0.035 \\ 0 \\ (4.33 - 0.0014) \end{matrix}$	130 (5.12)	6 (0.24)	6 (0.24)	-	12 (0.47)	165 (6.50)	45 (1.77)	-	9 (0.35)	$22 \begin{matrix} 0 \\ -0.013 \\ 0 \\ (0.87 - 0.0005) \end{matrix}$	30 (1.18)	40 (1.57)	12 (26.5)
20A2AAB	200 (7.87)	$114.3 \begin{matrix} 0 \\ -0.025 \\ 0 \\ (4.50 - 0.0010) \end{matrix}$	180 (7.09)	3.2 (0.13)	3 (0.12)	0.5 (0.020)	18 (0.71)	230 (9.06)	76 (2.99)	62 (2.44)	13.5 (0.53)	$35 \begin{matrix} +0.01 \\ 0 \\ +0.0004 \\ 0 \end{matrix}$	45 (1.77)	76 (2.99)	19 (41.9)
30A2AAB	200 (7.87)	$114.3 \begin{matrix} 0 \\ -0.025 \\ 0 \\ (4.50 - 0.0010) \end{matrix}$	180 (7.09)	3.2 (0.13)	3 (0.12)	0.5 (0.020)	18 (0.71)	230 (9.06)	76 (2.99)	62 (2.44)	13.5 (0.53)	$35 \begin{matrix} +0.01 \\ 0 \\ +0.0004 \\ 0 \end{matrix}$	45 (1.77)	76 (2.99)	23.5 (51.8)
44A2AAB	200 (7.87)	$114.3 \begin{matrix} 0 \\ -0.025 \\ 0 \\ (4.50 - 0.0010) \end{matrix}$	180 (7.09)	3.2 (0.13)	3 (0.12)	0.5 (0.020)	18 (0.71)	230 (9.06)	76 (2.99)	62 (2.44)	13.5 (0.53)	$35 \begin{matrix} +0.01 \\ 0 \\ +0.0004 \\ 0 \end{matrix}$	45 (1.77)	76 (2.99)	28.5 (62.8)

Note The Encoder uses an 8192-P/R incremental encoder.

Connector Wiring on Servomotor End

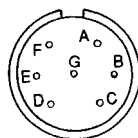

A	Phase U	E	Brake terminal
B	Phase V	F	Brake terminal
C	Phase W	G	-
D	FG (Frame Ground)		

5.5 to 11 kW Servomotors

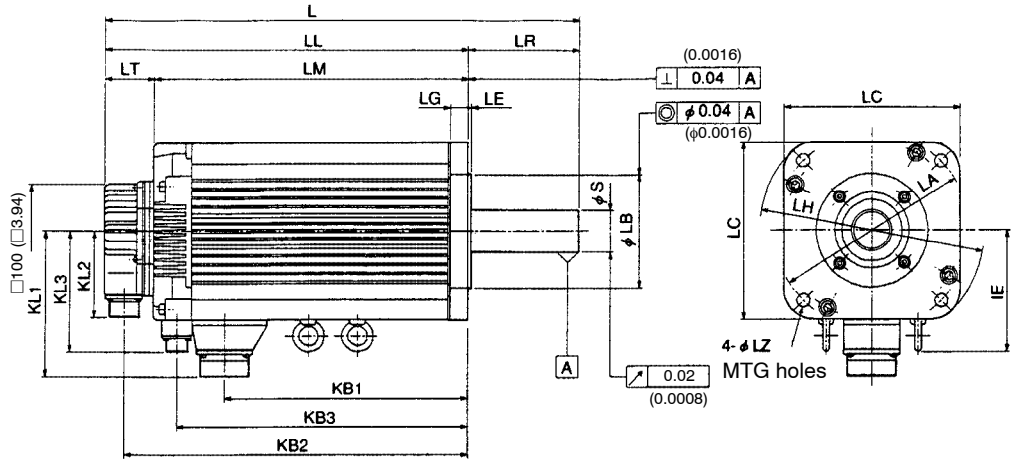

Shaft Extension (SGMG-55A2AAB and 75A2AAB)

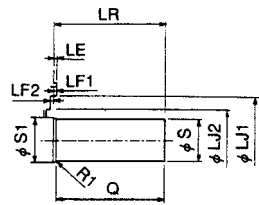

Shaft Extension (SGMG-1AA2AAB)

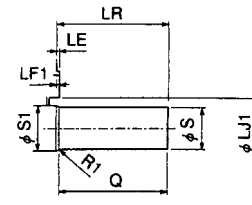

[mm (in)]

Model SGMG-	L	LL	LM	LR	LT	KB1	KB2	KB3	IE	KL1	KL2	KL3
55A2AAB	424 (16.69)	311 (12.24)	264 (10.39)	113 (4.45)	47 (1.85)	174 (6.85)	290 (11.42)	231 (9.09)	125 (4.92)	150 (5.91)	88 (3.46)	123 (4.84)
75A2AAB	498 (19.61)	385 (15.16)	338 (13.31)	113 (4.45)	47 (1.85)	248 (9.76)	364 (14.33)	305 (12.01)	125 (4.92)	150 (5.91)	88 (3.46)	123 (4.84)
1AA2AAB	499 (19.65)	383 (15.08)	340 (13.39)	116 (4.57)	43 (1.69)	258 (10.16)	362 (14.25)	315 (12.40)	142 (5.59)	168 (6.61)	88 (3.46)	142 (5.59)
1EA2AAB	635 (25.00)	519 (20.43)	473 (18.62)	116 (4.57)	46 (1.69)	343 (13.50)	477 (18.78)	415 (16.34)	142 (5.59)	168 (6.61)	88 (3.46)	142 (5.59)

Model SGMG-	Flange Dimensions [mm (in)]											Shaft End Dimensions [mm (in)]			Approx. Mass [kg (lb)]
	LA	LB	LC	LE	LF1	LF2	LG	LH	LJ1	LJ2	LZ	S	S1	Q	
55A2AAB	200 (7.87)	114.3 ⁰ _{-0.025} (4.50 - 0.0010)	180 (7.09)	3.2 (0.13)	3 (0.12)	0.5 (0.020)	18 (0.71)	230 (9.06)	76 (2.99)	62 (2.44)	13.5 (0.53)	42 ⁰ _{-0.016} (1.65 - 0.0006)	45 (1.77)	110 (4.33)	35 (1.38)
75A2AAB	200 (7.87)	114.3 ⁰ _{-0.025} (4.50 - 0.0010)	180 (7.09)	3.2 (0.13)	3 (0.12)	0.5 (0.020)	18 (0.71)	230 (9.06)	76 (2.99)	62 (2.44)	13.5 (0.53)	42 ⁰ _{-0.016} (1.65 - 0.0006)	45 (1.77)	110 (4.33)	45.5 (1.79)
1AA2AAB	235 (9.25)	200 ⁰ _{-0.046} (7.87 - 0.0018)	220 (8.66)	4 (0.16)	4 (0.16)	-	18 (0.71)	270 (10.63)	62 (2.44)	-	13.5 (0.53)	42 ⁰ _{-0.016} (1.65 - 0.0006)	45 (1.77)	110 (4.33)	65 (2.56)
1EA2AAB	235 (9.25)	200 ⁰ _{-0.046} (7.87 - 0.0018)	220 (8.66)	4 (0.16)	4 (0.16)	-	20 (0.79)	270 (10.63)	85 (3.35)	-	13.5 (0.53)	55 ^{+0.030} _{-0.011} (2.17 - 0.0004)	65 (2.56)	110 (4.33)	100 (3.94)

Note The Encoder uses an 8192 P/R incremental encoder.

Connector Wiring on Brake and Servomotor End



A	Brake terminal
B	Brake terminal
C	-

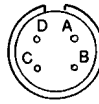

A	Phase U
B	Phase V
C	Phase W
D	FG (Frame Ground)

■ Servomotors with 15-bit and 8192 P/R Absolute Encoders

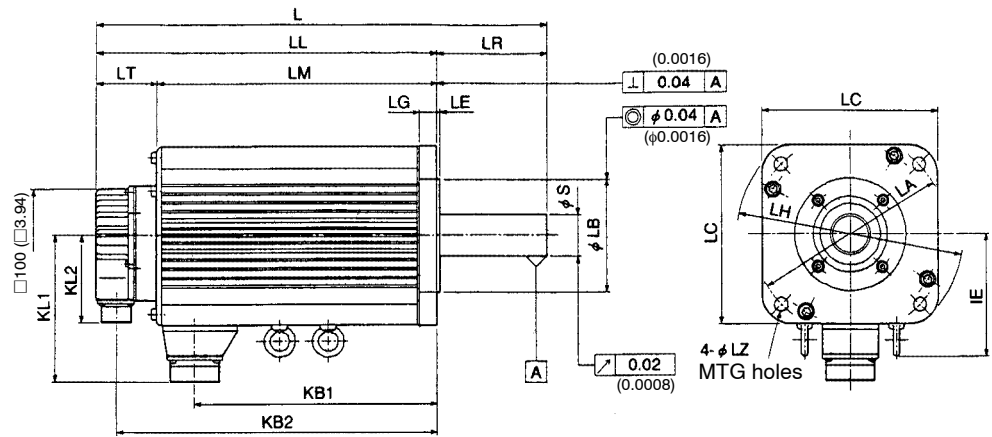

Shaft Extension
(SGMG-05ASA to 13ASA, 1AASA)

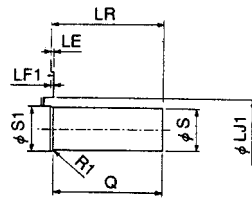

Shaft Extension
(SGMG-20ASA to 75ASA)

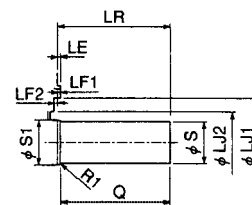

Servodrives Dimensional Drawings

9.1.1 SGMG-□□A□A Servomotors

[mm (in)]

Model SGMG-	L	LL	LM	LR	LT	KB1	KB2	IE	KL1	KL2
05ASA	210 (8.27)	152 (5.98)	92 (3.62)	58 (2.28)	60 (2.36)	65 (2.56)	131 (5.16)	—	109 (4.29)	88 (3.46)
09ASA	233 (9.17)	175 (6.89)	115 (4.53)	58 (2.28)	60 (2.36)	88 (3.46)	154 (6.06)	—	109 (4.29)	88 (3.46)
13ASA	257 (10.12)	199 (7.83)	139 (5.47)	58 (2.28)	60 (2.36)	112 (4.41)	178 (7.01)	—	109 (4.29)	88 (3.46)
20ASA	259 (10.20)	180 (7.09)	119 (4.69)	79 (3.11)	61 (2.40)	89 (3.50)	159 (6.26)	—	140 (5.51)	88 (3.46)
30ASA	285 (11.22)	206 (8.11)	145 (5.71)	79 (3.11)	61 (2.40)	115 (4.53)	185 (7.28)	—	140 (5.51)	88 (3.46)
44ASA	319 (12.56)	240 (9.45)	179 (7.05)	79 (3.11)	61 (2.40)	149 (5.87)	219 (8.62)	—	140 (5.51)	88 (3.46)
55ASA	387 (15.24)	274 (10.79)	213 (8.39)	113 (4.45)	61 (2.40)	174 (6.85)	253 (9.96)	125 (4.92)	150 (5.91)	88 (3.46)
75ASA	461 (18.15)	348 (13.70)	287 (11.30)	113 (4.45)	61 (2.40)	248 (9.76)	327 (12.87)	125 (4.92)	150 (5.91)	88 (3.46)
1AASA	468 (18.43)	352 (13.86)	291 (11.46)	116 (4.57)	61 (2.40)	251 (9.88)	331 (13.03)	142 (5.59)	168 (6.61)	88 (3.46)
1EASA	587 (23.11)	471 (18.54)	388 (15.28)	116 (4.57)	83 (3.27)	343 (13.50)	449 (17.68)	142 (5.59)	168 (6.61)	88 (3.46)

Model SGMG-	Flange Dimensions [mm (in)]											Shaft End Dimensions [mm (in)]			Approx. Mass [kg (lb)]
	LA	LB	LC	LE	LF1	LF2	LG	LH	LJ1	LJ2	LZ	S	S1	Q	
05ASA	145 (5.71)	$110 \begin{matrix} 0 \\ -0.035 \\ 0 \\ (4.33 - 0.0014) \end{matrix}$	130 (5.12)	6 (0.24)	6 (0.24)	-	12 (0.47)	165 (6.50)	45 (1.77)	-	9 (0.35)	$19 \begin{matrix} 0 \\ -0.013 \\ 0 \\ (0.75 - 0.0005) \end{matrix}$	30 (1.18)	40 (1.57)	5.9 (13.0)
09ASA	145 (5.71)	$110 \begin{matrix} 0 \\ -0.035 \\ 0 \\ (4.33 - 0.0014) \end{matrix}$	130 (5.12)	6 (0.24)	6 (0.24)	-	12 (0.47)	165 (6.50)	45 (1.77)	-	9 (0.35)	$19 \begin{matrix} 0 \\ -0.013 \\ 0 \\ (0.75 - 0.0005) \end{matrix}$	30 (1.18)	40 (1.57)	8.0 (17.6)
13ASA	145 (5.71)	$110 \begin{matrix} 0 \\ -0.035 \\ 0 \\ (4.33 - 0.0014) \end{matrix}$	130 (5.12)	6 (0.24)	6 (0.24)	-	12 (0.47)	165 (6.50)	45 (1.77)	-	9 (0.35)	$22 \begin{matrix} 0 \\ -0.013 \\ 0 \\ (0.87 - 0.0005) \end{matrix}$	30 (1.18)	40 (1.57)	10 (22.0)
20ASA	200 (7.87)	$114.3 \begin{matrix} 0 \\ -0.025 \\ 0 \\ (4.50 - 0.0010) \end{matrix}$	180 (7.09)	3.2 (0.13)	3 (0.12)	0.5 (0.020)	18 (0.71)	230 (9.06)	76 (2.99)	62 (2.44)	13.5 (0.53)	$35 \begin{matrix} +0.01 \\ 0 \\ +0.0004 \\ (1.38 \quad 0) \end{matrix}$	45 (1.77)	76 (2.99)	14 (30.9)
30ASA	200 (7.87)	$114.3 \begin{matrix} 0 \\ -0.025 \\ 0 \\ (4.50 - 0.0010) \end{matrix}$	180 (7.09)	3.2 (0.13)	3 (0.12)	0.5 (0.020)	18 (0.71)	230 (9.06)	76 (2.99)	62 (2.44)	13.5 (0.53)	$35 \begin{matrix} +0.01 \\ 0 \\ +0.0004 \\ (1.38 \quad 0) \end{matrix}$	45 (1.77)	76 (2.99)	18.5 (40.8)
44ASA	200 (7.87)	$114.3 \begin{matrix} 0 \\ -0.025 \\ 0 \\ (4.50 - 0.0010) \end{matrix}$	180 (7.09)	3.2 (0.13)	3 (0.12)	0.5 (0.020)	18 (0.71)	230 (9.06)	76 (2.99)	62 (2.44)	13.5 (0.53)	$35 \begin{matrix} +0.01 \\ 0 \\ +0.0004 \\ (1.38 \quad 0) \end{matrix}$	45 (1.77)	76 (2.99)	24 (52.9)
55ASA	200 (7.87)	$114.3 \begin{matrix} 0 \\ -0.025 \\ 0 \\ (4.50 - 0.0010) \end{matrix}$	180 (7.09)	3.2 (0.13)	3 (0.12)	0.5 (0.020)	18 (0.71)	230 (9.06)	76 (2.99)	62 (2.44)	13.5 (0.53)	$42 \begin{matrix} 0 \\ -0.016 \\ 0 \\ (1.65 - 0.0006) \end{matrix}$	45 (1.77)	110 (4.33)	30 (66.1)
75ASA	200 (7.87)	$114.3 \begin{matrix} 0 \\ -0.025 \\ 0 \\ (4.50 - 0.0010) \end{matrix}$	180 (7.09)	3.2 (0.13)	3 (0.12)	0.5 (0.020)	18 (0.71)	230 (9.06)	76 (2.99)	62 (2.44)	13.5 (0.53)	$42 \begin{matrix} 0 \\ -0.016 \\ 0 \\ (1.65 - 0.0006) \end{matrix}$	45 (1.77)	110 (4.33)	40 (88.2)
1AASA	235 (9.25)	$200 \begin{matrix} 0 \\ -0.046 \\ 0 \\ (7.87 - 0.0018) \end{matrix}$	220 (8.66)	4 (0.16)	4 (0.16)	-	18 (0.71)	270 (10.63)	62 (2.44)	-	13.5 (0.53)	$42 \begin{matrix} 0 \\ -0.016 \\ 0 \\ (1.65 - 0.0006) \end{matrix}$	45 (1.77)	110 (4.33)	58 (127)
1EASA	235 (9.25)	$200 \begin{matrix} 0 \\ -0.046 \\ 0 \\ (7.87 - 0.0018) \end{matrix}$	220 (8.66)	4 (0.16)	4 (0.16)	-	20 (0.79)	270 (10.63)	85 (3.35)	-	13.5 (0.53)	$55 \begin{matrix} +0.030 \\ -0.011 \\ +0.0012 \\ (2.17 - 0.0004) \end{matrix}$	65 (2.56)	110 (4.33)	86 (3.94)

Note 1. The Encoder uses a 15-bit, (8192 P/R) absolute encoder.

2. Eyebolts are not provided with the SGMG-05ASA to 44ASA Servomotors.

Connector Wiring on Encoder End

Receptacle: MS3102A20-29

Plug (To be prepared by customer) (L type): MS3108B20-29S or (Straight type) MS3106B20-29S

Cable Clamp: (To be prepared by customer) MS3057-12A

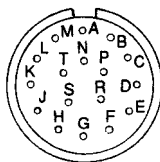

A	A Channel Output	K	-
B	\bar{A} Channel Output	L	-
C	B Channel Output	M	-
D	\bar{B} Channel Output	N	-
E	Z (C) Channel Output	P	-
F	\bar{Z} (\bar{C}) Channel Output	R	Reset
G	0 V	S	0 V (battery)
H	+5 VDC	T	3.6 V (battery)
J	FG (Frame Ground)		

- Note 1.** Terminals K to P are not used. Do not connect anything.
2. Receptacle, plug and cable clamp are common regardless of motor capacity.

Connectors Wiring on Servomotor End

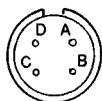

A	Phase U
B	Phase V
C	Phase W
D	Ground terminal

■ Servomotors with 15-bit (8192 P/R) Absolute Encoders and Brakes

0.5 to 4.4 kW Servomotors

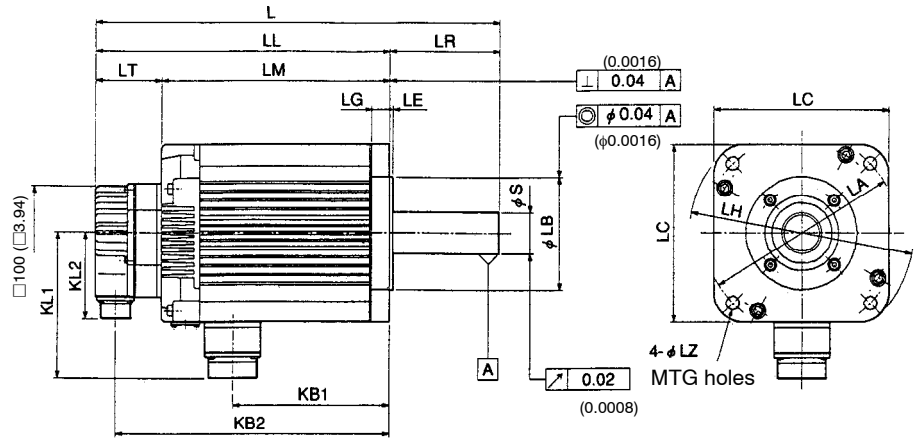

Shaft Extension
(SGMG-05SAAB to 13ASAAB)

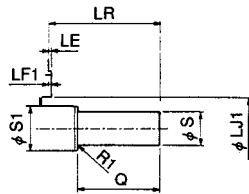

Shaft Extension
(SGMG-20ASAAB to 44ASAAB)

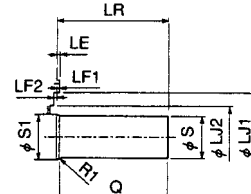

[mm (in)]

Model SGMG-	L	LL	LM	LR	LT	KB1	KB2	KL1	KL2
05ASAAB	248 (9.76)	190 (7.48)	129 (5.08)	58 (2.28)	61 (2.40)	56 (2.20)	169 (6.65)	120 (4.72)	88 (3.46)
09ASAAB	271 (10.67)	213 (8.39)	152 (5.98)	58 (2.28)	61 (2.40)	79 (3.11)	192 (7.56)	120 (4.72)	88 (3.46)
13ASAAB	295 (11.61)	237 (9.33)	176 (6.93)	58 (2.28)	61 (2.40)	103 (4.06)	216 (8.50)	120 (4.72)	88 (3.46)
20ASAAB	310 (12.20)	231 (9.09)	170 (6.69)	79 (3.11)	61 (2.40)	79 (3.11)	210 (8.27)	146 (5.75)	88 (3.46)
30ASAAB	336 (13.23)	257 (10.12)	196 (7.72)	79 (3.11)	61 (2.40)	105 (4.13)	236 (9.29)	146 (5.75)	88 (3.46)
44ASAAB	370 (14.57)	291 (11.46)	230 (9.06)	79 (3.11)	61 (2.40)	139 (5.47)	270 (10.63)	146 (5.75)	88 (3.46)

Servodrives Dimensional Drawings

9.1.1 SGMG-□□□□A Servomotors

Model SGMG-	Flange Dimensions [mm (in)]											Shaft End Dimensions [mm (in)]			Approx. Mass [kg (in)]
	LA	LB	LC	LE	LF1	LF2	LG	LH	LJ1	LJ2	LZ	S	S1	Q	
05ASAAB	145 (5.71)	$110 \begin{smallmatrix} 0 \\ -0.035 \\ 0 \\ 4.33 - 0.0014 \end{smallmatrix}$	130 (5.12)	6 (0.24)	6 (0.24)	-	12 (0.47)	165 (6.50)	45 (1.77)	-	9 (0.35)	$19 \begin{smallmatrix} 0 \\ -0.013 \\ 0 \\ 0.75 - 0.0005 \end{smallmatrix}$	30 (1.18)	40 (1.57)	7.9 (17.4)
09ASAAB	145 (5.71)	$110 \begin{smallmatrix} 0 \\ -0.035 \\ 0 \\ 4.33 - 0.0014 \end{smallmatrix}$	130 (5.12)	6 (0.24)	6 (0.24)	-	12 (0.47)	165 (6.50)	45 (1.77)	-	9 (0.35)	$19 \begin{smallmatrix} 0 \\ -0.013 \\ 0 \\ 0.75 - 0.0005 \end{smallmatrix}$	30 (1.18)	40 (1.57)	10 (22.0)
13ASAAB	145 (5.71)	$110 \begin{smallmatrix} 0 \\ -0.035 \\ 0 \\ 4.33 - 0.0014 \end{smallmatrix}$	130 (5.12)	6 (0.24)	6 (0.24)	-	12 (0.47)	165 (6.50)	45 (1.77)	-	9 (0.35)	$22 \begin{smallmatrix} 0 \\ -0.013 \\ 0 \\ 0.87 - 0.0005 \end{smallmatrix}$	30 (1.18)	40 (1.57)	12 (26.5)
20ASAAB	200 (7.87)	$114.3 \begin{smallmatrix} 0 \\ -0.025 \\ 0 \\ 4.50 - 0.0010 \end{smallmatrix}$	180 (7.09)	3.2 (0.13)	3 (0.12)	0.5 (0.020)	18 (0.71)	230 (9.06)	76 (2.99)	62 (2.44)	13.5 (0.53)	$35 \begin{smallmatrix} +0.01 \\ 0 \\ +0.0004 \\ 1.38 \\ 0 \end{smallmatrix}$	45 (1.77)	76 (2.99)	19.5 (43.0)
30ASAAB	200 (7.87)	$114.3 \begin{smallmatrix} 0 \\ -0.025 \\ 0 \\ 4.50 - 0.0010 \end{smallmatrix}$	180 (7.09)	3.2 (0.13)	3 (0.12)	0.5 (0.020)	18 (0.71)	230 (9.06)	76 (2.99)	62 (2.44)	13.5 (0.53)	$35 \begin{smallmatrix} +0.01 \\ 0 \\ +0.0004 \\ 1.38 \\ 0 \end{smallmatrix}$	45 (1.77)	76 (2.99)	23.5 (51.8)
44ASAAB	200 (7.87)	$114.3 \begin{smallmatrix} 0 \\ -0.025 \\ 0 \\ 4.50 - 0.0010 \end{smallmatrix}$	180 (7.09)	3.2 (0.13)	3 (0.12)	0.5 (0.020)	18 (0.71)	230 (9.06)	76 (2.99)	62 (2.44)	13.5 (0.53)	$35 \begin{smallmatrix} +0.01 \\ 0 \\ +0.0004 \\ 1.38 \\ 0 \end{smallmatrix}$	45 (1.77)	76 (2.99)	29 (63.9)

Note The Encoder uses a 15-bit (8192 P/R) absolute encoder.

Connector Wiring on Motor End

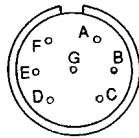

A	Phase U	E	Brake terminal
B	Phase V	F	Brake terminal
C	Phase W	G	-
D	FG (Frame Ground)		

5.5 to 15 kW Servomotors

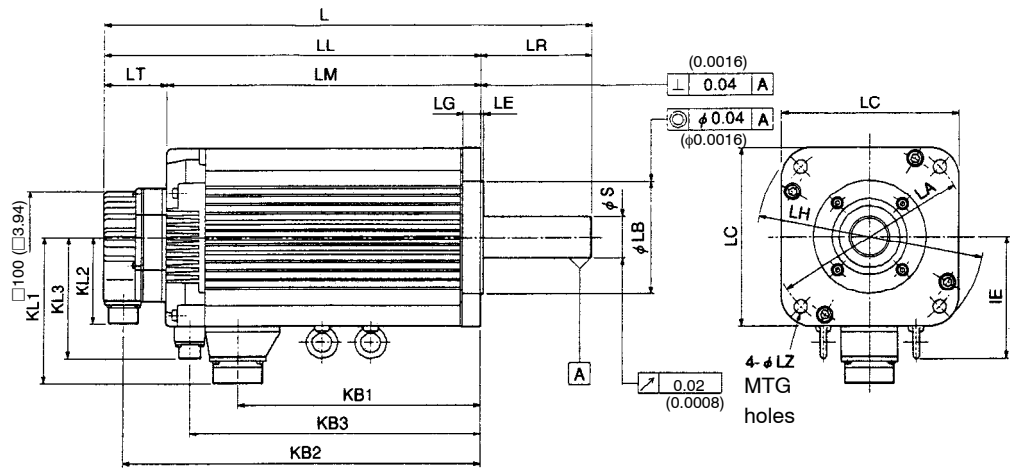

Shaft Extension
(SGMG-55ASAAB and 75ASAAB)

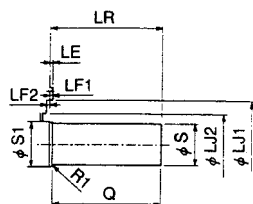

Shaft Extension
(SGMG-1AASAAB)

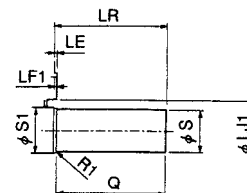

[mm (in)]

Model SGMG-	L	LL	LM	LR	LT	KB1	KB2	KB3	IE	KL1	KL2	KL3
55ASAAB	438 (17.24)	325 (12.80)	264 (10.39)	113 (4.45)	61 (2.40)	174 (6.85)	304 (11.97)	231 (9.09)	125 (4.92)	150 (5.91)	88 (3.46)	123 (4.84)
75ASAAB	512 (20.16)	399 (15.71)	338 (13.31)	113 (4.45)	61 (2.40)	248 (9.76)	378 (14.88)	305 (12.01)	125 (4.92)	150 (5.91)	88 (3.46)	123 (4.84)
1AASAAB	513 (20.20)	397 (15.63)	340 (13.39)	116 (4.57)	57 (2.24)	258 (10.16)	376 (14.80)	315 (12.40)	142 (5.59)	168 (6.61)	88 (3.46)	142 (5.59)
1EASAAB	649 (25.55)	533 (20.98)	473 (18.62)	116 (4.57)	60 (2.36)	343 (13.50)	511 (20.12)	415 (16.34)	142 (5.59)	168 (6.61)	88 (3.46)	142 (5.59)

Model SGMG-	Flange Dimensions [mm (in)]											Shaft End Dimensions [mm (in)]			Approx. Mass [kg (lb)]
	LA	LB	LC	LE	LF1	LF2	LG	LH	LJ1	LJ2	LZ	S	S1	Q	
55ASAAB	200 (7.87)	114.3 ⁰ _{-0.025} (4.50 - 0.0010)	180 (7.09)	3.2 (0.13)	3 (0.12)	0.5 (0.020)	18 (0.71)	230 (9.06)	76 (2.99)	62 (2.44)	13.5 (0.53)	42 ⁰ _{-0.016} (1.65 - 0.0006)	45 (1.77)	110 (4.33)	36 (79.4)
75ASAAB	200 (7.87)	114.3 ⁰ _{-0.025} (4.50 - 0.0010)	180 (7.09)	3.2 (0.13)	3 (0.12)	0.5 (0.020)	18 (0.71)	230 (9.06)	76 (2.99)	62 (2.44)	13.5 (0.53)	42 ⁰ _{-0.016} (1.65 - 0.0006)	45 (1.77)	110 (4.33)	50 (110)
1AASAAB	235 (9.25)	200 ⁰ _{-0.046} (7.87 - 0.0018)	220 (8.66)	4 (0.16)	4 (0.16)	-	18 (0.71)	270 (10.63)	62 (2.44)	-	13.5 (0.53)	42 ⁰ _{-0.016} (1.65 - 0.0006)	45 (1.77)	110 (4.33)	65.5 (144)
1EASAAB	235 (9.25)	200 ⁰ _{-0.046} (7.87 - 0.0018)	220 (8.66)	4 (0.16)	4 (0.16)	-	20 (0.79)	270 (10.63)	85 (3.35)	-	13.5 (0.53)	55 ^{+0.030} _{-0.011} (2.17 - 0.0004)	65 (2.56)	110 (4.33)	100 (3.94)

Note The Encoder uses a 15-bit (8192 P/R) absolute encoder.

Connector Wiring on Brake and Servomotor End



A	Brake terminal
B	Brake terminal
C	-

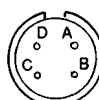

A	Phase U
B	Phase V
C	Phase W
D	FG (Frame Ground)

9.1.2 SGMG-□□A□B Servomotors

■ Servomotors with 8192 P/R Incremental Encoders

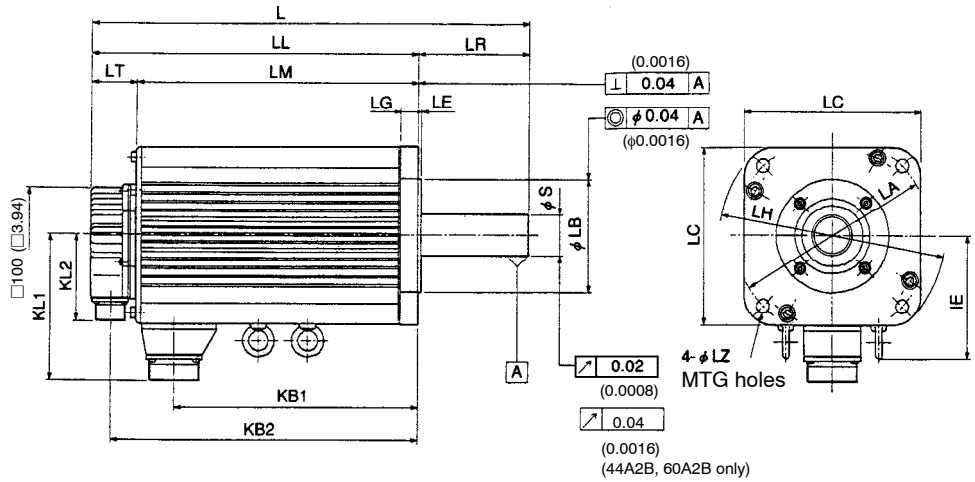

Shaft Extension
(SGMG-03A2B to 09A2B)

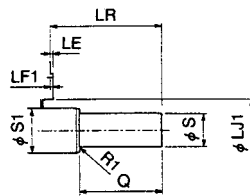

Shaft Extension
(SGMG-12A2B to 60A2B)

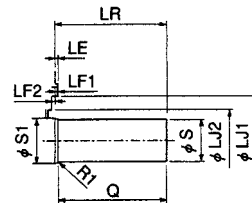

[mm (in)]

Model SGMG-	L	LL	LM	LR	LT	KB1	KB2	IE	KL1	KL2
03A2B	196 (7.72)	138 (5.43)	92 (3.62)	58 (2.28)	46 (1.81)	65 (2.56)	117 (4.61)	—	109 (4.29)	88 (3.46)
06A2B	219 (8.62)	161 (6.34)	115 (4.53)	58 (2.28)	46 (1.81)	88 (3.46)	140 (5.51)	—	109 (4.29)	88 (3.46)
09A2B	243 (9.57)	185 (7.28)	139 (5.47)	58 (2.28)	46 (1.81)	112 (4.41)	164 (6.46)	—	109 (4.29)	88 (3.46)
12A2B	245 (9.65)	166 (6.54)	119 (4.69)	79 (3.11)	47 (1.85)	89 (3.50)	145 (5.71)	—	140 (5.51)	88 (3.46)
20A2B	271 (10.67)	192 (7.56)	145 (5.71)	79 (3.11)	47 (1.85)	115 (4.53)	171 (6.73)	—	140 (5.51)	88 (3.46)
30A2B	305 (12.01)	226 (8.90)	179 (7.05)	79 (3.11)	47 (1.85)	149 (5.87)	205 (8.07)	—	140 (5.51)	88 (3.46)
44A2B	373 (14.69)	260 (10.24)	213 (8.39)	113 (4.45)	47 (1.85)	174 (6.85)	239 (9.41)	125 (4.92)	150 (5.91)	88 (3.46)
60A2B	447 (17.60)	334 (13.15)	287 (11.30)	113 (4.45)	47 (1.85)	248 (9.76)	313 (12.32)	125 (4.92)	150 (5.91)	88 (3.46)

Model SGMG-	Flange Dimensions [mm (in)]											Shaft End Dimensions [mm (in)]			Approx. Mass [kg (lb)]
	LA	LB	LC	LE	LF1	LF2	LG	LH	LJ1	LJ2	LZ	S	S1	Q	
03A2B	145 (5.71)	$110 \begin{matrix} 0 \\ -0.035 \\ 0 \\ (4.33 - 0.0014) \end{matrix}$	130 (5.12)	6 (0.24)	6 (0.24)	-	12 (0.47)	165 (6.50)	45 (1.77)	-	9 (0.35)	$19 \begin{matrix} 0 \\ -0.013 \\ 0 \\ (0.75 - 0.0005) \end{matrix}$	30 (1.18)	40 (1.57)	5.5 (12.1)
06A2B	145 (5.71)	$110 \begin{matrix} 0 \\ -0.035 \\ 0 \\ (4.33 - 0.0014) \end{matrix}$	130 (5.12)	6 (0.24)	6 (0.24)	-	12 (0.47)	165 (6.50)	45 (1.77)	-	9 (0.35)	$19 \begin{matrix} 0 \\ -0.013 \\ 0 \\ (0.75 - 0.0005) \end{matrix}$	30 (1.18)	40 (1.57)	7.6 (16.8)
09A2B	145 (5.71)	$110 \begin{matrix} 0 \\ -0.035 \\ 0 \\ (4.33 - 0.0014) \end{matrix}$	130 (5.12)	6 (0.24)	6 (0.24)	-	12 (0.47)	165 (6.50)	45 (1.77)	-	9 (0.35)	$22 \begin{matrix} 0 \\ -0.013 \\ 0 \\ (0.87 - 0.0005) \end{matrix}$	30 (1.18)	40 (1.57)	9.6 (21.2)
12A2B	200 (7.87)	$114.3 \begin{matrix} 0 \\ -0.025 \\ 0 \\ (4.50 - 0.0010) \end{matrix}$	180 (7.09)	3.2 (0.13)	3 (0.12)	0.5 (0.020)	18 (0.71)	230 (9.06)	76 (2.99)	62 (2.44)	13.5 (0.53)	$35 \begin{matrix} +0.01 \\ 0 \\ +0.0004 \\ (1.38 \quad 0) \end{matrix}$	45 (1.77)	76 (2.99)	14 (30.9)
20A2B	200 (7.87)	$114.3 \begin{matrix} 0 \\ -0.025 \\ 0 \\ (4.50 - 0.0010) \end{matrix}$	180 (7.09)	3.2 (0.13)	3 (0.12)	0.5 (0.020)	18 (0.71)	230 (9.06)	76 (2.99)	62 (2.44)	13.5 (0.53)	$35 \begin{matrix} +0.01 \\ 0 \\ +0.0004 \\ (1.38 \quad 0) \end{matrix}$	45 (1.77)	76 (2.99)	18 (39.7)
30A2B	200 (7.87)	$114.3 \begin{matrix} 0 \\ -0.025 \\ 0 \\ (4.50 - 0.0010) \end{matrix}$	180 (7.09)	3.2 (0.13)	3 (0.12)	0.5 (0.020)	18 (0.71)	230 (9.06)	76 (2.99)	62 (2.44)	13.5 (0.53)	$35 \begin{matrix} +0.01 \\ 0 \\ +0.0004 \\ (1.38 \quad 0) \end{matrix}$	45 (1.77)	76 (2.99)	23 (50.7)
44A2B	200 (7.87)	$114.3 \begin{matrix} 0 \\ -0.025 \\ 0 \\ (4.50 - 0.0010) \end{matrix}$	180 (7.09)	3.2 (0.13)	3 (0.12)	0.5 (0.020)	18 (0.71)	230 (9.06)	76 (2.99)	62 (2.44)	13.5 (0.53)	$42 \begin{matrix} 0 \\ -0.016 \\ 0 \\ (1.65 - 0.0006) \end{matrix}$	45 (1.77)	110 (4.33)	30 (66.1)
60A2B	200 (7.87)	$114.3 \begin{matrix} 0 \\ -0.025 \\ 0 \\ (4.50 - 0.0010) \end{matrix}$	180 (7.09)	3.2 (0.13)	3 (0.12)	0.5 (0.020)	18 (0.71)	230 (9.06)	76 (2.99)	62 (2.44)	13.5 (0.53)	$42 \begin{matrix} 0 \\ -0.016 \\ 0 \\ (1.65 - 0.0006) \end{matrix}$	45 (1.77)	110 (4.33)	40 (88.2)

Note 1. The Encoder uses an 8192-P/R incremental encoder.

2. Eyebolts are not provided with the SGMG-03A2B to 30A2B Servomotors.

Connector Wiring on Encoder End

Receptacle: MS3102A20-29

Plug (To be prepared by customer) (L type): MS3108B20-29S or (Straight type)
MS3106B20-29S

Cable Clamp: (To be prepared by customer) MS3057-12A

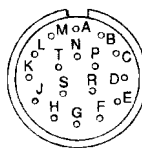

Receptacle: MS3102A20-29P

Applicable plug (provided by the user)

Plug: MS3108B20-29S

Cable clamp: MS3057-12A

A	A Channel Output	K	-
B	\bar{A} Channel Output	L	-
C	B Channel Output	M	-
D	\bar{B} Channel Output	N	-
E	C Channel Output	P	-
F	\bar{C} Channel Output	R	-
G	0 V	S	-
H	+5 VDC	T	-
J	FG (Frame Ground)		

Note 1. Terminals K to T are not used.

2. Receptacle, plug and cable clamp are common regardless of motor capacity.

Connector Wiring on Servomotor End

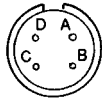

A	Phase U
B	Phase V
C	Phase W
D	Ground terminal

■ Servomotors with 8192 P/R Incremental Encoders and Brakes

0.3 to 3.0 kW Servomotors

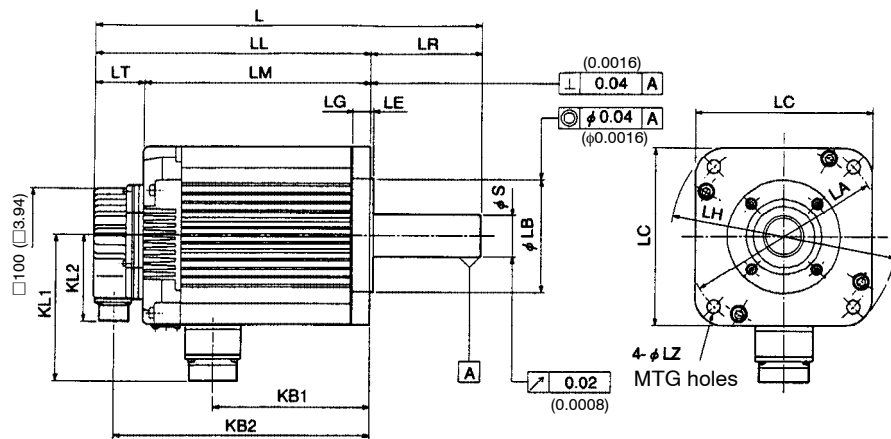

Shaft Extension
(SGMG-03A2BAB to 09A2BAB)

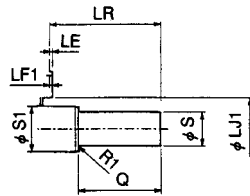

Shaft Extension
(SGMG-12A2BAB to 30A2BAB)

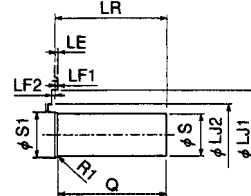

[mm (in)]

Model SGMG-	L	LL	LM	LR	LT	KB1	KB2	KL1	KL2
03A2BAB	234 (9.21)	176 (6.93)	129 (5.08)	58 (2.28)	47 (1.85)	56 (2.20)	155 (6.10)	120 (4.72)	88 (3.46)
06A2BAB	257 (10.12)	199 (7.83)	152 (5.98)	58 (2.28)	47 (1.85)	79 (3.11)	178 (7.01)	120 (4.72)	88 (3.46)
09A2BAB	281 (11.06)	223 (8.78)	176 (6.93)	58 (2.28)	47 (1.85)	103 (4.06)	202 (7.95)	120 (4.72)	88 (3.46)
12A2BAB	296 (11.65)	217 (8.54)	170 (6.69)	79 (3.11)	47 (1.85)	79 (3.11)	196 (7.72)	146 (5.75)	88 (3.46)
20A2BAB	322 (12.68)	243 (9.57)	196 (7.72)	79 (3.11)	47 (1.85)	105 (4.13)	222 (8.74)	146 (5.75)	88 (3.46)
30A2BAB	356 (14.02)	277 (10.91)	230 (9.06)	79 (3.11)	47 (1.85)	139 (54.72)	256 (10.08)	146 (5.75)	88 (3.46)

Model SGMG-	Flange Dimensions [mm (in)]											Shaft End Dimensions [mm (in)]			Approx. Mass [kg (lb)]
	LA	LB	LC	LE	LF1	LF2	LG	LH	LJ1	LJ2	LZ	S	S1	Q	
03A2BAB	145 (5.71)	$110 \begin{smallmatrix} 0 \\ -0.035 \\ 0 \\ (4.33 - 0.0014) \end{smallmatrix}$	130 (5.12)	6 (0.24)	6 (0.24)	-	12 (0.47)	165 (6.50)	45 (1.77)	-	9 (0.35)	$19 \begin{smallmatrix} 0 \\ -0.013 \\ 0 \\ (0.75 - 0.0005) \end{smallmatrix}$	30 (1.18)	40 (1.57)	7.5 (16.5)
06A2BAB	145 (5.71)	$110 \begin{smallmatrix} 0 \\ -0.035 \\ 0 \\ (4.33 - 0.0014) \end{smallmatrix}$	130 (5.12)	6 (0.24)	6 (0.24)	-	12 (0.47)	165 (6.50)	45 (1.77)	-	9 (0.35)	$19 \begin{smallmatrix} 0 \\ -0.013 \\ 0 \\ (0.75 - 0.0005) \end{smallmatrix}$	30 (1.18)	40 (1.57)	9.6 (21.2)
09A2BAB	145 (5.71)	$110 \begin{smallmatrix} 0 \\ -0.035 \\ 0 \\ (4.33 - 0.0014) \end{smallmatrix}$	130 (5.12)	6 (0.24)	6 (0.24)	-	12 (0.47)	165 (6.50)	45 (1.77)	-	9 (0.35)	$22 \begin{smallmatrix} 0 \\ -0.013 \\ 0 \\ (0.87 - 0.0005) \end{smallmatrix}$	30 (1.18)	40 (1.57)	12 (26.5)
12A2BAB	200 (7.87)	$114.3 \begin{smallmatrix} 0 \\ -0.025 \\ 0 \\ (4.50 - 0.0010) \end{smallmatrix}$	180 (7.09)	3.2 (0.13)	3 (0.12)	0.5 (0.020)	18 (0.71)	230 (9.06)	76 (2.99)	62 (2.44)	13.5 (0.53)	$35 \begin{smallmatrix} +0.01 \\ 0 \\ +0.0004 \\ (1.38 \quad 0) \end{smallmatrix}$	45 (1.77)	76 (2.99)	19 (41.9)
20A2BAB	200 (7.87)	$114.3 \begin{smallmatrix} 0 \\ -0.025 \\ 0 \\ (4.50 - 0.0010) \end{smallmatrix}$	180 (7.09)	3.2 (0.13)	3 (0.12)	0.5 (0.020)	18 (0.71)	230 (9.06)	76 (2.99)	62 (2.44)	13.5 (0.53)	$35 \begin{smallmatrix} +0.01 \\ 0 \\ +0.0004 \\ (1.38 \quad 0) \end{smallmatrix}$	45 (1.77)	76 (2.99)	23.5 (51.8)
30A2BAB	200 (7.87)	$114.3 \begin{smallmatrix} 0 \\ -0.025 \\ 0 \\ (4.50 - 0.0010) \end{smallmatrix}$	180 (7.09)	3.2 (0.13)	3 (0.12)	0.5 (0.020)	18 (0.71)	230 (9.06)	76 (2.99)	62 (2.44)	13.5 (0.53)	$35 \begin{smallmatrix} +0.01 \\ 0 \\ +0.0004 \\ (1.38 \quad 0) \end{smallmatrix}$	45 (1.77)	76 (2.99)	28.5 (62.8)

Note The Encoder uses an 8192 P/R incremental encoder.

Connector Wiring on Servomotor End

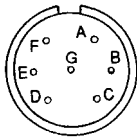

A	Phase U	E	Brake terminal
B	Phase V	F	Brake terminal
C	Phase W	G	-
D	FG (Frame Ground)		

4.4 to 6.0 kW Servomotors

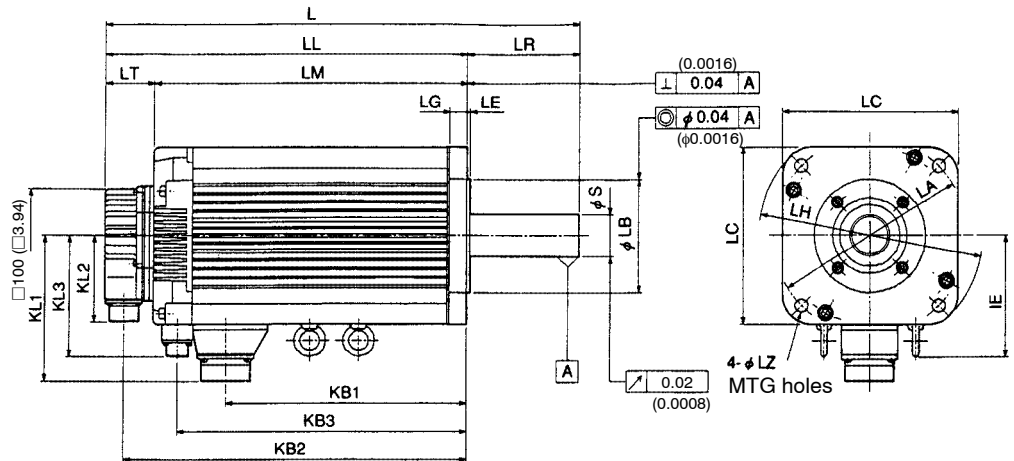

Shaft Extension

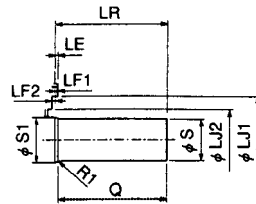

[mm (in)]

Model SGMG-	L	LL	LM	LR	LT	KB1	KB2	KB3	IE	KL1	KL2	KL3
44A2BAB	424 (16.69)	311 (12.24)	264 (10.39)	113 (4.45)	47 (1.85)	174 (6.85)	290 (11.42)	231 (9.09)	125 (4.92)	150 (5.91)	88 (3.46)	123 (4.84)
60A2BAB	498 (19.61)	385 (15.16)	338 (13.31)	113 (4.45)	47 (1.85)	248 (9.76)	364 (14.33)	305 (12.01)	125 (4.92)	150 (5.91)	88 (3.46)	123 (4.84)

Model SGMG-	Flange Dimensions [mm (in)]											Shaft End Dimensions [mm (in)]			Approx. Mass [kg (lb)]
	LA	LB	LC	LE	LF1	LF2	LG	LH	LJ1	LJ2	LZ	S	S1	Q	
44A2BAB	200 (7.87)	114.3 ⁰ _{-0.025} (4.50 - 0.0010)	180 (7.09)	3.2 (0.13)	3 (0.12)	0.5 (0.020)	18 (0.71)	230 (9.06)	76 (2.99)	62 (2.44)	13.5 (0.53)	42 ⁰ _{-0.016} (1.65 - 0.0006)	45 (1.77)	110 (4.33)	35 (77.2)
60A2BAB	200 (7.87)	114.3 ⁰ _{-0.025} (4.50 - 0.0010)	180 (7.09)	3.2 (0.13)	3 (0.12)	0.5 (0.020)	18 (0.71)	230 (9.06)	76 (2.99)	62 (2.44)	13.5 (0.53)	42 ⁰ _{-0.016} (1.65 - 0.0006)	45 (1.77)	110 (4.33)	45.5 (100)

Note The Encoder uses an 8192 P/R incremental encoder.

Connector Wiring on Brake and Servomotor End



A	Brake terminal
B	Brake terminal
C	-

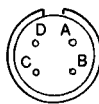

A	Phase U
B	Phase V
C	Phase W
D	FG (Frame Ground)

■ Servomotors with 15-bit (8192 P/R) Absolute Encoders

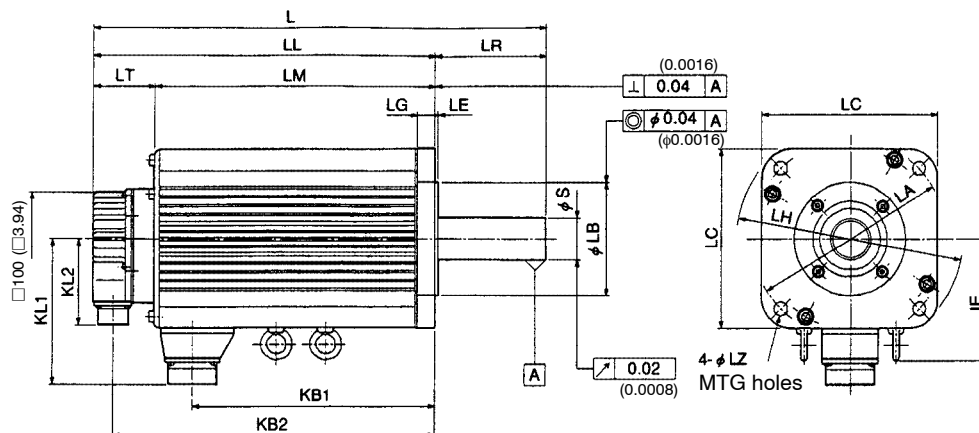

Shaft Extension
(SGMG-03ASB to 09ASB)

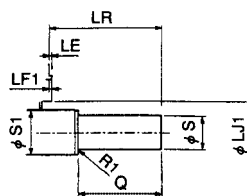

Shaft Extension
(SGMG-12ASB to 60ASB)

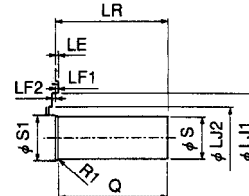

[mm (in)]

Model SGMG-	L	LL	LM	LR	LT	KB1	KB2	IE	KL1	KL2
03ASB	210 (8.27)	152 (5.98)	92 (3.62)	58 (2.28)	60 (2.36)	65 (2.56)	131 (5.16)	—	109 (4.29)	88 (3.46)
06ASB	233 (9.17)	175 (6.89)	115 (4.53)	58 (2.28)	60 (2.36)	88 (3.46)	154 (6.06)	—	109 (4.29)	88 (3.46)
09ASB	257 (10.12)	199 (7.83)	139 (5.47)	58 (2.28)	60 (2.36)	112 (4.41)	178 (7.01)	—	109 (4.29)	88 (3.46)
12ASB	259 (10.20)	180 (7.09)	119 (4.69)	79 (3.11)	61 (2.40)	89 (3.50)	159 (6.26)	—	140 (5.51)	88 (3.46)
20ASB	285 (11.22)	206 (8.11)	145 (5.71)	79 (3.11)	61 (2.40)	115 (4.53)	185 (7.28)	—	140 (5.51)	88 (3.46)
30ASB	319 (12.56)	240 (9.45)	179 (7.05)	79 (3.11)	61 (2.40)	149 (5.87)	219 (8.62)	—	140 (5.51)	88 (3.46)
44ASB	387 (15.24)	274 (10.79)	213 (8.39)	113 (4.45)	61 (2.40)	174 (6.85)	253 (9.96)	125 (4.92)	150 (5.91)	88 (3.46)
60ASB	461 (18.15)	348 (13.70)	287 (11.30)	113 (4.45)	61 (2.40)	248 (9.76)	327 (12.87)	125 (4.92)	150 (5.91)	88 (3.46)

Model SGMG-	Flange Dimensions [mm (in)]											Shaft End Dimensions [mm (in)]			Approx. Mass [kg (lb)]
	LA	LB	LC	LE	LF1	LF2	LG	LH	LJ1	LJ2	LZ	S	S1	Q	
03ASB	145 (5.71)	$110 \begin{matrix} 0 \\ -0.035 \\ 0 \\ (4.33 - 0.0014) \end{matrix}$	130 (5.12)	6 (0.24)	6 (0.24)	-	12 (0.47)	165 (6.50)	45 (1.77)	-	9 (0.35)	$19 \begin{matrix} 0 \\ -0.013 \\ 0 \\ (0.75 - 0.0005) \end{matrix}$	30 (1.18)	40 (1.57)	5.9 (13.0)
06ASB	145 (5.71)	$110 \begin{matrix} 0 \\ -0.035 \\ 0 \\ (4.33 - 0.0014) \end{matrix}$	130 (5.12)	6 (0.24)	6 (0.24)	-	12 (0.47)	165 (6.50)	45 (1.77)	-	9 (0.35)	$19 \begin{matrix} 0 \\ -0.013 \\ 0 \\ (0.75 - 0.0005) \end{matrix}$	30 (1.18)	40 (1.57)	8.0 (17.6)
09ASB	145 (5.71)	$110 \begin{matrix} 0 \\ -0.035 \\ 0 \\ (4.33 - 0.0014) \end{matrix}$	130 (5.12)	6 (0.24)	6 (0.24)	-	12 (0.47)	165 (6.50)	45 (1.77)	-	9 (0.35)	$22 \begin{matrix} 0 \\ -0.013 \\ 0 \\ (0.87 - 0.0005) \end{matrix}$	30 (1.18)	40 (1.57)	10 (22.0)
12ASB	200 (7.87)	$114.3 \begin{matrix} 0 \\ -0.025 \\ 0 \\ (4.50 - 0.0010) \end{matrix}$	180 (7.09)	3.2 (0.13)	3 (0.12)	0.5 (0.020)	18 (0.71)	230 (9.06)	76 (2.99)	62 (2.44)	13.5 (0.53)	$35 \begin{matrix} +0.01 \\ 0 \\ +0.0004 \\ (1.38 \ 0) \end{matrix}$	45 (1.77)	76 (2.99)	14 (30.9)
20ASB	200 (7.87)	$114.3 \begin{matrix} 0 \\ -0.025 \\ 0 \\ (4.50 - 0.0010) \end{matrix}$	180 (7.09)	3.2 (0.13)	3 (0.12)	0.5 (0.020)	18 (0.71)	230 (9.06)	76 (2.99)	62 (2.44)	13.5 (0.53)	$35 \begin{matrix} +0.01 \\ 0 \\ +0.0004 \\ (1.38 \ 0) \end{matrix}$	45 (1.77)	76 (2.99)	18.5 (40.8)
30ASB	200 (7.87)	$114.3 \begin{matrix} 0 \\ -0.025 \\ 0 \\ (4.50 - 0.0010) \end{matrix}$	180 (7.09)	3.2 (0.13)	3 (0.12)	0.5 (0.020)	18 (0.71)	230 (9.06)	76 (2.99)	62 (2.44)	13.5 (0.53)	$35 \begin{matrix} +0.01 \\ 0 \\ +0.0004 \\ (1.38 \ 0) \end{matrix}$	45 (1.77)	76 (2.99)	24 (52.9)
44ASB	200 (7.87)	$114.3 \begin{matrix} 0 \\ -0.025 \\ 0 \\ (4.50 - 0.0010) \end{matrix}$	180 (7.09)	3.2 (0.13)	3 (0.12)	0.5 (0.020)	18 (0.71)	230 (9.06)	76 (2.99)	62 (2.44)	13.5 (0.53)	$42 \begin{matrix} 0 \\ -0.016 \\ 0 \\ (1.65 - 0.0006) \end{matrix}$	45 (1.77)	110 (4.33)	30 (66.1)
60ASB	200 (7.87)	$114.3 \begin{matrix} 0 \\ -0.025 \\ 0 \\ (4.50 - 0.0010) \end{matrix}$	180 (7.09)	3.2 (0.13)	3 (0.12)	0.5 (0.020)	18 (0.71)	230 (9.06)	76 (2.99)	62 (2.44)	13.5 (0.53)	$42 \begin{matrix} 0 \\ -0.016 \\ 0 \\ (1.65 - 0.0006) \end{matrix}$	45 (1.77)	110 (4.33)	40 (88.2)

Note 1. The Encoder uses a 15-bit (8192 P/R) absolute encoder.

2. Eyebolts are not provided with the SGMG-03ASB to 30ASB Servomotors.

Connector Wiring on Encoder End

Receptacle: MS3102A20-29

Plug (To be prepared by customer) (L type): MS3108B20-29S or (Straight type) MS3106B20-29S

Cable Clamp: (To be prepared by customer) MS3057-12A

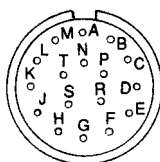

A	A Channel Output	K	-
B	\bar{A} Channel Output	L	-
C	B Channel Output	M	-
D	\bar{B} Channel Output	N	-
E	Z Channel Output	P	-
F	\bar{Z} Channel Output	R	Reset
G	0 V	S	0 V (battery)
H	+5 VDC	T	3.6 V (battery)
J	FG (Frame Ground)		

- Note 1.** Terminals K to P are not used.
2. Receptacle, plug and cable clamp are common regardless of motor capacity.

Connector Wiring on Servomotor End

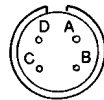

A	Phase U
B	Phase V
C	Phase W
D	Ground terminal

■ Servomotors with 15-bit (8192 P/R) Absolute Encoders and Brakes

0.3 to 3.0 kW Servomotors

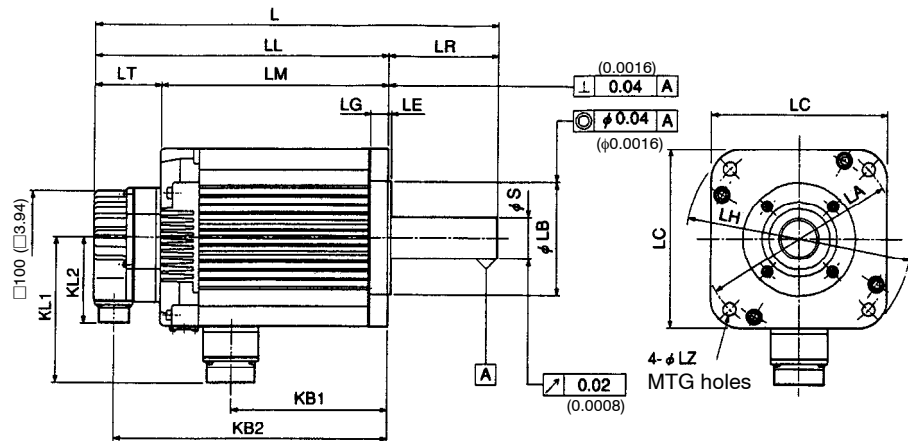

Shaft Extension
(SGMG-03ASBAB to 09ASBAB)

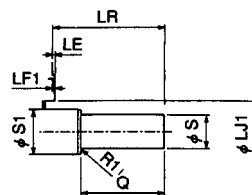

Shaft Extension
(SGMG-12ASBAB to 30ASBAB)

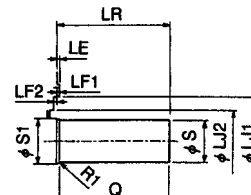

Servodrives Dimensional Drawings

9.1.2 SGMG-□□A□B Servomotors

[mm (in)]

Model SGMG-	L	LL	LM	LR	LT	KB1	KB2	KL1	KL2
03ASBAB	248 (9.76)	190 (7.48)	129 (5.08)	58 (2.28)	61 (2.40)	56 (2.20)	169 (6.65)	120 (4.72)	88 (3.46)
06ASBAB	271 (10.67)	213 (8.39)	152 (5.98)	58 (2.28)	61 (2.40)	79 (3.11)	192 (7.56)	120 (4.72)	88 (3.46)
09ASBAB	295 (11.61)	237 (9.33)	176 (6.93)	58 (2.28)	61 (2.40)	103 (4.06)	216 (8.50)	120 (4.72)	88 (3.46)
12ASBAB	310 (12.20)	231 (9.09)	170 (6.69)	79 (3.11)	61 (2.40)	79 (3.11)	210 (8.27)	146 (5.75)	88 (3.46)
20ASBAB	336 (13.23)	257 (10.12)	196 (7.72)	79 (3.11)	61 (2.40)	105 (4.13)	236 (9.29)	146 (5.75)	88 (3.46)
30ASBAB	370 (14.57)	291 (11.46)	230 (9.06)	79 (3.11)	61 (2.40)	139 (5.47)	270 (10.63)	146 (5.75)	88 (3.46)

Model SGMG-	Flange Dimensions [mm (in)]											Shaft End Dimensions [mm (in)]			Approx. Mass [kg (lb)]
	LA	LB	LC	LE	LF1	LF2	LG	LH	LJ1	LJ2	LZ	S	S1	Q	
03ASBAB	145 (5.71)	$110 \begin{matrix} 0 \\ -0.035 \\ 0 \\ (4.33 - 0.0014) \end{matrix}$	130 (5.12)	6 (0.24)	6 (0.24)	-	12 (0.47)	165 (6.50)	45 (1.77)	-	9 (0.35)	$19 \begin{matrix} 0 \\ -0.013 \\ 0 \\ (0.75 - 0.0005) \end{matrix}$	30 (1.18)	40 (1.57)	7.9 (17.4)
06ASBAB	145 (5.71)	$110 \begin{matrix} 0 \\ -0.035 \\ 0 \\ (4.33 - 0.0014) \end{matrix}$	130 (5.12)	6 (0.24)	6 (0.24)	-	12 (0.47)	165 (6.50)	45 (1.77)	-	9 (0.35)	$19 \begin{matrix} 0 \\ -0.013 \\ 0 \\ (0.75 - 0.0005) \end{matrix}$	30 (1.18)	40 (1.57)	10 (22.0)
09ASBAB	145 (5.71)	$110 \begin{matrix} 0 \\ -0.035 \\ 0 \\ (4.33 - 0.0014) \end{matrix}$	130 (5.12)	6 (0.24)	6 (0.24)	-	12 (0.47)	165 (6.50)	45 (1.77)	-	9 (0.35)	$22 \begin{matrix} 0 \\ -0.013 \\ 0 \\ (0.87 - 0.0005) \end{matrix}$	30 (1.18)	40 (1.57)	12 (26.5)
12ASBAB	200 (7.87)	$114.3 \begin{matrix} 0 \\ -0.025 \\ 0 \\ (4.50 - 0.0010) \end{matrix}$	180 (7.09)	3.2 (0.13)	3 (0.12)	0.5 (0.020)	18 (0.71)	230 (9.06)	76 (2.99)	62 (2.44)	13.5 (0.53)	$35 \begin{matrix} +0.01 \\ 0 \\ +0.0004 \\ (1.38 \ 0) \end{matrix}$	45 (1.77)	76 (2.99)	19.5 (43.0)
20ASBAB	200 (7.87)	$114.3 \begin{matrix} 0 \\ -0.025 \\ 0 \\ (4.50 - 0.0010) \end{matrix}$	180 (7.09)	3.2 (0.13)	3 (0.12)	0.5 (0.020)	18 (0.71)	230 (9.06)	76 (2.99)	62 (2.44)	13.5 (0.53)	$35 \begin{matrix} +0.01 \\ 0 \\ +0.0004 \\ (1.38 \ 0) \end{matrix}$	45 (1.77)	76 (2.99)	23.5 (51.8)
30ASBAB	200 (7.87)	$114.3 \begin{matrix} 0 \\ -0.025 \\ 0 \\ (4.50 - 0.0010) \end{matrix}$	180 (7.09)	3.2 (0.13)	3 (0.12)	0.5 (0.020)	18 (0.71)	230 (9.06)	76 (2.99)	62 (2.44)	13.5 (0.53)	$35 \begin{matrix} +0.01 \\ 0 \\ +0.0004 \\ (1.38 \ 0) \end{matrix}$	45 (1.77)	76 (2.99)	29 (63.9)

Note The Encoder uses a 15-bit (8192 P/R) absolute encoder.

Connector Wiring on Servomotor End

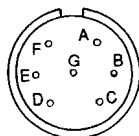

A	Phase U	E	Brake terminal
B	Phase V	F	Brake terminal
C	Phase W	G	-
D	FG (Frame Ground)		

4.4 to 6.0 kW Servomotors

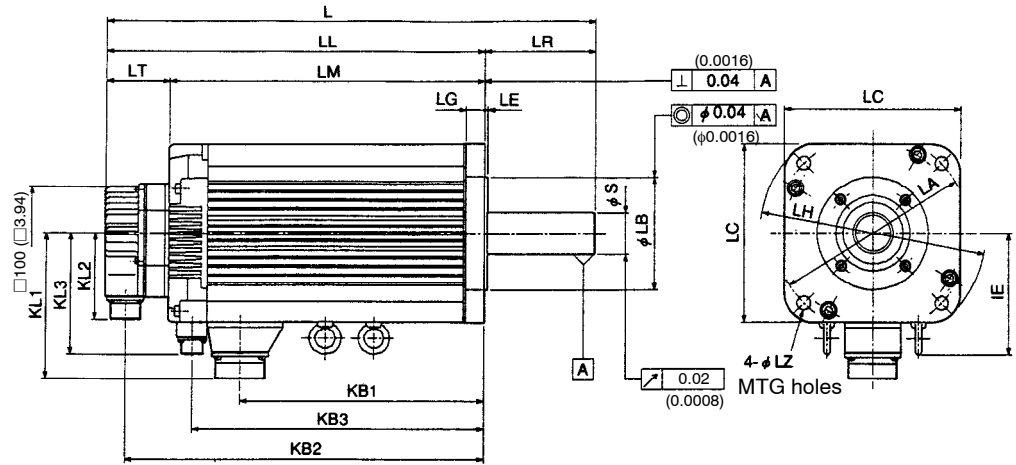

Shaft Extension

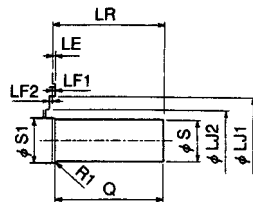

[mm (in)]

Model SGMG-	L	LL	LM	LR	LT	KB1	KB2	KB3	IE	KL1	KL2	KL3
44ASBAB	438 (17.24)	325 (12.80)	264 (10.39)	113 (4.45)	61 (2.40)	174 (6.85)	304 (11.97)	231 (9.09)	125 (4.92)	150 (5.91)	88 (3.46)	123 (4.84)
60ASBAB	512 (20.16)	399 (15.71)	338 (13.31)	113 (4.45)	61 (2.40)	248 (9.76)	378 (14.88)	305 (12.01)	125 (4.92)	150 (5.91)	88 (3.46)	123 (4.84)

Model SGMG-	L	LL	LM	LR	LT	KB1	KB2	KB3	IE	KL1	KL2	KL3
44ASBAB	438 (17.24)	325 (12.80)	264 (10.39)	113 (4.45)	61 (2.40)	174 (6.85)	304 (11.97)	231 (9.09)	125 (4.92)	150 (5.91)	88 (3.46)	123 (4.84)
60ASBAB	512 (20.16)	399 (15.71)	338 (13.31)	113 (4.45)	61 (2.40)	248 (9.76)	378 (14.88)	305 (12.01)	125 (4.92)	150 (5.91)	88 (3.46)	123 (4.84)

Model SGMG-	Flange Dimensions [mm (in)]											Shaft End Dimensions [mm (in)]			Approx. Mass [kg (lb)]
	LA	LB	LC	LE	LF1	LF2	LG	LH	LJ1	LJ2	LZ	S	S1	Q	
44ASBAB	200 (7.87)	114.3 ⁰ _{-0.025} (4.50 - 0.0010)	180 (7.09)	3.2 (0.13)	3 (0.12)	0.5 (0.020)	18 (0.71)	230 (9.06)	76 (2.99)	62 (2.44)	13.5 (0.53)	42 ⁰ _{-0.016} (1.65 - 0.0006)	45 (1.77)	110 (4.33)	36 (79.4)
60ASBAB	200 (7.87)	114.3 ⁰ _{-0.025} (4.50 - 0.0010)	180 (7.09)	3.2 (0.13)	3 (0.12)	0.5 (0.020)	18 (0.71)	230 (9.06)	76 (2.99)	62 (2.44)	13.5 (0.53)	42 ⁰ _{-0.016} (1.65 - 0.0006)	45 (1.77)	110 (4.33)	50 (110)

Note The Encoder uses a 15-bit (8192 P/R) absolute encoder.

Connector Wiring on Brake and Servomotor End



A	Brake terminal
B	Brake terminal
C	-

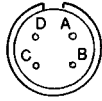

A	Phase U
B	Phase V
C	Phase W
D	FG (Frame Ground)

9.1.3 SGMS-□□A Servomotors

■ Servomotors with 4096 P/R Incremental Encoders

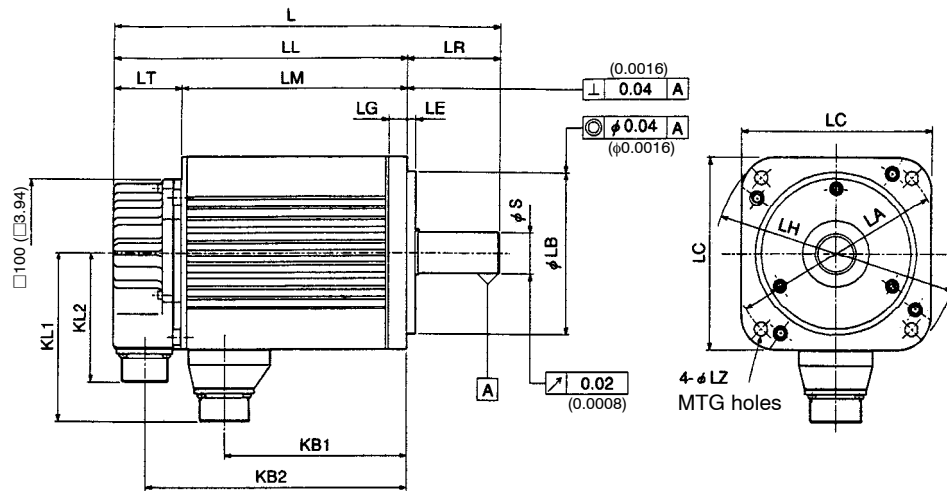

Shaft Extension

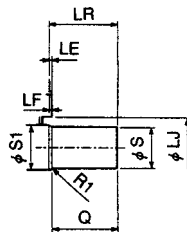

[mm (in)]

Model SGMS-	L	LL	LM	LR	LT	KB1	KB2	KL1	KL2
10A6A	194 (7.64)	149 (5.87)	103 (4.06)	45 (1.77)	46 (1.81)	76 (2.99)	128 (5.04)	96 (3.78)	87 (3.43)
15A6A	220 (8.66)	175 (6.89)	129 (5.08)	45 (1.77)	46 (1.81)	102 (4.02)	154 (6.06)	96 (3.78)	87 (3.43)
20A6A	243 (9.57)	198 (7.80)	152 (5.98)	45 (1.77)	46 (1.81)	125 (4.92)	177 (6.97)	96 (3.78)	87 (3.43)
30A6A	262 (10.31)	199 (7.83)	153 (6.02)	63 (2.48)	46 (1.81)	122 (4.80)	178 (7.01)	114 (4.49)	87 (3.43)
40A6A	299 (11.77)	236 (9.29)	190 (7.48)	63 (2.48)	46 (1.81)	159 (6.26)	215 (8.46)	114 (4.49)	87 (3.43)
50A6A	339 (13.35)	276 (10.87)	230 (9.06)	63 (2.48)	46 (1.81)	199 (7.83)	255 (10.04)	114 (4.49)	87 (3.43)

Model SGMS-	Flange Dimensions [mm (in)]									Shaft End Dimensions [mm (in)]			Approx. Mass [kg (lb)]
	LA	LB	LC	LE	LF	LG	LH	LJ	LZ	S	S1	Q	
10A6A	115 (4.53)	$95 - 0.035$ $\left(\begin{matrix} 0 \\ 3.74 - 0.0014 \end{matrix} \right)$	100 (3.94)	3 (0.12)	3 (0.12)	10 (0.39)	130 (5.12)	45 (1.77)	7 (0.28)	$24 - 0.013$ $\left(\begin{matrix} 0 \\ 0.94 - 0.0005 \end{matrix} \right)$	30 (1.18)	40 (1.57)	4.6 (10.1)
15A6A	115 (4.53)	$95 - 0.035$ $\left(\begin{matrix} 0 \\ 3.74 - 0.0014 \end{matrix} \right)$	100 (3.94)	3 (0.12)	3 (0.12)	10 (0.39)	130 (5.12)	45 (1.77)	7 (0.28)	$24 - 0.013$ $\left(\begin{matrix} 0 \\ 0.94 - 0.0005 \end{matrix} \right)$	30 (1.18)	40 (1.57)	5.8 (12.8)
20A6A	115 (4.53)	$95 - 0.035$ $\left(\begin{matrix} 0 \\ 3.74 - 0.0014 \end{matrix} \right)$	100 (3.94)	3 (0.12)	3 (0.12)	10 (0.39)	130 (5.12)	45 (1.77)	7 (0.28)	$24 - 0.013$ $\left(\begin{matrix} 0 \\ 0.94 - 0.0005 \end{matrix} \right)$	30 (1.18)	40 (1.57)	7.0 (15.4)
30A6A	145 (5.71)	$110 - 0.035$ $\left(\begin{matrix} 0 \\ 4.33 - 0.0014 \end{matrix} \right)$	130 (5.12)	6 (0.24)	6 (0.24)	12 (0.47)	165 (6.50)	45 (1.77)	9 (0.35)	$28 - 0.013$ $\left(\begin{matrix} 0 \\ 1.10 - 0.0005 \end{matrix} \right)$	30 (1.18)	55 (2.17)	11 (24.3)
40A6A	145 (5.71)	$110 - 0.035$ $\left(\begin{matrix} 0 \\ 4.33 - 0.0014 \end{matrix} \right)$	130 (5.12)	6 (0.24)	6 (0.24)	12 (0.47)	165 (6.50)	45 (1.77)	9 (0.35)	$28 - 0.013$ $\left(\begin{matrix} 0 \\ 1.10 - 0.0005 \end{matrix} \right)$	30 (1.18)	55 (2.17)	14 (30.9)
50A6A	145 (5.71)	$110 - 0.035$ $\left(\begin{matrix} 0 \\ 4.33 - 0.0014 \end{matrix} \right)$	130 (5.12)	6 (0.24)	6 (0.24)	12 (0.47)	165 (6.50)	45 (1.77)	9 (0.35)	$28 - 0.013$ $\left(\begin{matrix} 0 \\ 1.10 - 0.0005 \end{matrix} \right)$	30 (1.18)	55 (2.17)	17 (37.5)

Note The Encoder uses an 4096 P/R incremental encoder.

Connector Wiring on Encoder End

Receptacle: MS3102A20-29

Plug (To be prepared by customer) (L type): MS3108B20-29S or (Straight type)
MS3106B20-29S

Cable Clamp: (To be prepared by customer) MS3057-12A

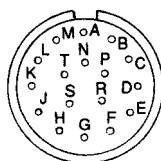

A	A Channel Output	K	-
B	\bar{A} Channel Output	L	-
C	B Channel Output	M	-
D	\bar{B} Channel Output	N	-
E	C Channel Output	P	-
F	\bar{C} Channel Output	R	-
G	0 V	S	-
H	+5 VDC	T	-
J	FG (Frame Ground)		

- Note 1.** Terminals K to T are not used. Do not connect anything.
2. Receptacle, plug and cable clamp are common regardless of motor capacity.

Connector Wiring on Servomotor End

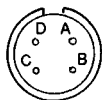

A	Phase U
B	Phase V
C	Phase W
D	Ground terminal

■ Servomotors with 4096 P/R Incremental Encoders and Brakes

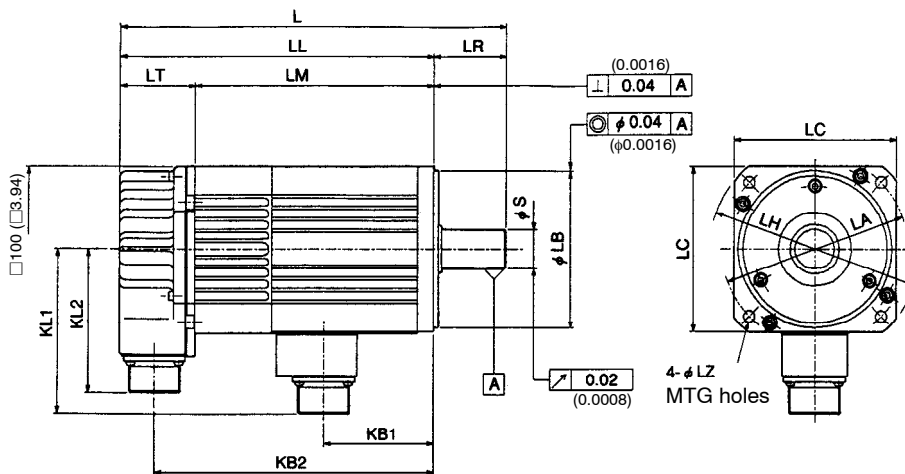

9

Shaft Extension

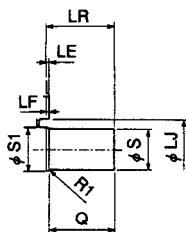

[mm (in)]

Model SGMS-	L	LL	LM	LR	LT	KB1	KB2	KL1	KL2
10A6AAB	238 (9.37)	193 (7.60)	147 (5.79)	45 (1.77)	46 (1.81)	67 (2.64)	172 (6.77)	100 (3.94)	87 (3.43)
15A6AAB	264 (10.39)	219 (8.62)	173 (6.81)	45 (1.77)	46 (1.81)	93 (3.66)	198 (7.80)	100 (3.94)	87 (3.43)
20A6AAB	287 (11.30)	242 (9.53)	196 (7.72)	45 (1.77)	46 (1.81)	116 (4.57)	221 (8.70)	100 (3.94)	87 (3.43)
30A6AAB	300 (11.81)	237 (9.33)	191 (7.52)	63 (2.48)	46 (1.81)	113 (4.45)	216 (8.50)	119 (4.69)	87 (3.43)
40A6AAB	336 (13.23)	274 (10.79)	228 (8.98)	63 (2.48)	46 (1.81)	150 (5.91)	253 (9.96)	119 (4.69)	87 (3.43)
50A6AAB	337 (13.27)	314 (12.36)	268 (10.55)	63 (2.48)	46 (1.81)	190 (7.48)	293 (11.54)	119 (4.69)	87 (3.43)

Model SGMS-	Flange Dimensions [mm (in)]									Shaft End Dimensions [mm (in)]			Approx. Mass [kg (lb)]
	LA	LB	LC	LE	LF	LG	LH	LJ	LZ	S	S1	Q	
10A6AAB	115 (4.53)	$95 - \begin{matrix} 0 \\ -0.035 \\ 0 \\ 3.74 - 0.0014 \end{matrix}$	100 (3.94)	3 (0.12)	3 (0.12)	10 (0.39)	130 (5.12)	45 (1.77)	7 (0.28)	$24 - \begin{matrix} 0 \\ -0.013 \\ 0 \\ 0.94 - 0.0005 \end{matrix}$	30 (1.18)	40 (1.57)	6.0 (13.2)
15A6AAB	115 (4.53)	$95 - \begin{matrix} 0 \\ -0.035 \\ 0 \\ 3.74 - 0.0014 \end{matrix}$	100 (3.94)	3 (0.12)	3 (0.12)	10 (0.39)	130 (5.12)	45 (1.77)	7 (0.28)	$24 - \begin{matrix} 0 \\ -0.013 \\ 0 \\ 0.94 - 0.0005 \end{matrix}$	30 (1.18)	40 (1.57)	7.5 (16.5)
20A6AAB	115 (4.53)	$95 - \begin{matrix} 0 \\ -0.035 \\ 0 \\ 3.74 - 0.0014 \end{matrix}$	100 (3.94)	3 (0.12)	3 (0.12)	10 (0.39)	130 (5.12)	45 (1.77)	7 (0.28)	$24 - \begin{matrix} 0 \\ -0.013 \\ 0 \\ 0.94 - 0.0005 \end{matrix}$	30 (1.18)	40 (1.57)	8.5 (18.7)
30A6AAB	145 (5.71)	$110 - \begin{matrix} 0 \\ -0.035 \\ 0 \\ 4.33 - 0.0014 \end{matrix}$	130 (5.12)	6 (0.24)	6 (0.24)	12 (0.47)	165 (6.50)	45 (1.77)	9 (0.35)	$28 - \begin{matrix} 0 \\ -0.013 \\ 0 \\ 1.10 - 0.0005 \end{matrix}$	30 (1.18)	55 (2.17)	14 (30.9)
40A6AAB	145 (5.71)	$110 - \begin{matrix} 0 \\ -0.035 \\ 0 \\ 4.33 - 0.0014 \end{matrix}$	130 (5.12)	6 (0.24)	6 (0.24)	12 (0.47)	165 (6.50)	45 (1.77)	9 (0.35)	$28 - \begin{matrix} 0 \\ -0.013 \\ 0 \\ 1.10 - 0.0005 \end{matrix}$	30 (1.18)	55 (2.17)	17 (37.5)
50A6AAB	145 (5.71)	$110 - \begin{matrix} 0 \\ -0.035 \\ 0 \\ 4.33 - 0.0014 \end{matrix}$	130 (5.12)	6 (0.24)	6 (0.24)	12 (0.47)	165 (6.50)	45 (1.77)	9 (0.35)	$28 - \begin{matrix} 0 \\ -0.013 \\ 0 \\ 1.10 - 0.0005 \end{matrix}$	30 (1.18)	55 (2.17)	20 (44.1)

Note The Encoder uses an 4096 P/R incremental encoder.

Connector Wiring on Servomotor End

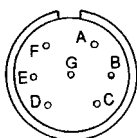

A	Phase U	E	Brake terminal
B	Phase V	F	Brake terminal
C	Phase W	G	-
D	FG (Frame Ground)		

■ Servomotors with 15-bit (8192 P/R) Absolute Encoders

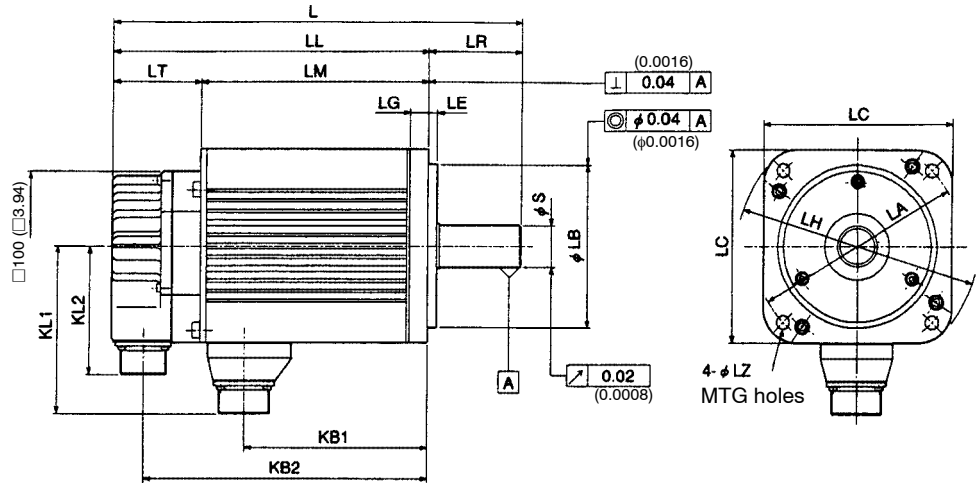

Shaft Extension

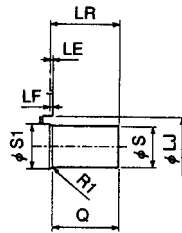

[mm (in)]

Model SGMS-	L	LL	LM	LR	LT	KB1	KB2	KL1	KL2
10ASA	208 (8.19)	163 (6.42)	103 (4.06)	45 (1.77)	60 (2.36)	76 (2.99)	142 (5.59)	96 (3.78)	87 (3.43)
15ASA	234 (9.21)	189 (7.44)	129 (5.08)	45 (1.77)	60 (2.36)	102 (4.02)	168 (6.61)	96 (3.78)	87 (3.43)
20ASA	257 (10.12)	212 (8.35)	152 (5.98)	45 (1.77)	60 (2.36)	125 (4.92)	191 (7.52)	96 (3.78)	87 (3.43)
30ASA	276 (10.87)	213 (8.39)	153 (6.02)	63 (2.48)	60 (2.36)	122 (4.80)	192 (7.56)	114 (4.49)	87 (3.43)
40ASA	313 (12.32)	250 (9.84)	190 (7.48)	63 (2.48)	60 (2.36)	159 (6.26)	229 (9.02)	114 (4.49)	87 (3.43)
50ASA	353 (13.90)	290 (11.42)	230 (9.06)	63 (2.48)	60 (2.36)	199 (7.83)	269 (10.59)	114 (4.49)	87 (3.43)

Model SGMS-	Flange Dimensions [mm (in)]									Shaft End Dimensions [mm (in)]			Approx. Mass [kg (lb)]
	LA	LB	LC	LE	LF	LG	LH	LJ	LZ	S	S1	Q	
10ASA	115 (4.53)	$95 \begin{matrix} 0 \\ -0.035 \\ 0 \\ (3.74 - 0.0014) \end{matrix}$	100 (3.94)	3 (0.12)	3 (0.12)	10 (0.39)	130 (5.12)	45 (1.77)	7 (0.28)	$24 \begin{matrix} 0 \\ -0.013 \\ 0 \\ (0.94 - 0.0005) \end{matrix}$	30 (1.18)	40 (1.57)	5.0 (11.0)
15ASA	115 (4.53)	$95 \begin{matrix} 0 \\ -0.035 \\ 0 \\ (3.74 - 0.0014) \end{matrix}$	100 (3.94)	3 (0.12)	3 (0.12)	10 (0.39)	130 (5.12)	45 (1.77)	7 (0.28)	$24 \begin{matrix} 0 \\ -0.013 \\ 0 \\ (0.94 - 0.0005) \end{matrix}$	30 (1.18)	40 (1.57)	6.2 (13.7)
20ASA	115 (4.53)	$95 \begin{matrix} 0 \\ -0.035 \\ 0 \\ (3.74 - 0.0014) \end{matrix}$	100 (3.94)	3 (0.12)	3 (0.12)	10 (0.39)	130 (5.12)	45 (1.77)	7 (0.28)	$24 \begin{matrix} 0 \\ -0.013 \\ 0 \\ (0.94 - 0.0005) \end{matrix}$	30 (1.18)	40 (1.57)	7.4 (16.3)
30ASA	145 (5.71)	$110 \begin{matrix} 0 \\ -0.035 \\ 0 \\ (4.33 - 0.0014) \end{matrix}$	130 (5.12)	6 (0.24)	6 (0.24)	12 (0.47)	165 (6.50)	45 (1.77)	9 (0.35)	$28 \begin{matrix} 0 \\ -0.013 \\ 0 \\ (1.10 - 0.0005) \end{matrix}$	30 (1.18)	55 (2.17)	11.5 (25.4)
40ASA	145 (5.71)	$110 \begin{matrix} 0 \\ -0.035 \\ 0 \\ (4.33 - 0.0014) \end{matrix}$	130 (5.12)	6 (0.24)	6 (0.24)	12 (0.47)	165 (6.50)	45 (1.77)	9 (0.35)	$28 \begin{matrix} 0 \\ -0.013 \\ 0 \\ (1.10 - 0.0005) \end{matrix}$	30 (1.18)	55 (2.17)	14.5 (32.0)
50ASA	145 (5.71)	$110 \begin{matrix} 0 \\ -0.035 \\ 0 \\ (4.33 - 0.0014) \end{matrix}$	130 (5.12)	6 (0.24)	6 (0.24)	12 (0.47)	165 (6.50)	45 (1.77)	9 (0.35)	$28 \begin{matrix} 0 \\ -0.013 \\ 0 \\ (1.10 - 0.0005) \end{matrix}$	30 (1.18)	55 (2.17)	17.5 (38.6)

Note The Encoder uses a 15-bit (8192 P/R) absolute encoder.

Connector Wiring on Encoder End

Receptacle: MS3102A20-29

Plug: (To be prepared by customer) (L type): MS3108B20-29S or (Straight type) MS3106B20-29S

Cable Clamp: (To be prepared by customer) MS3057-12A

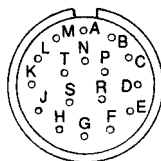

A	A Channel Output	K	-
B	\bar{A} Channel Output	L	-
C	B Channel Output	M	-
D	\bar{B} Channel Output	N	-
E	Z (C) Channel Output	P	-
F	\bar{Z} (\bar{C}) Channel Output	R	Reset
G	0 V	S	0 V (battery)
H	+5 VDC	T	3.6 V (battery)
J	FG (Frame Ground)		

- Note 1.** Terminals K to P are not used. Do not connect anything.
- 2.** Receptacle, plug and cable clamp are common regardless of motor capacity.

Connector Wiring on Servomotor End

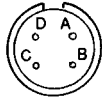

A	Phase U
B	Phase V
C	Phase W
D	Ground terminal

■ Servomotors with 15-bit (8192 P/R) Absolute Encoders and Brakes

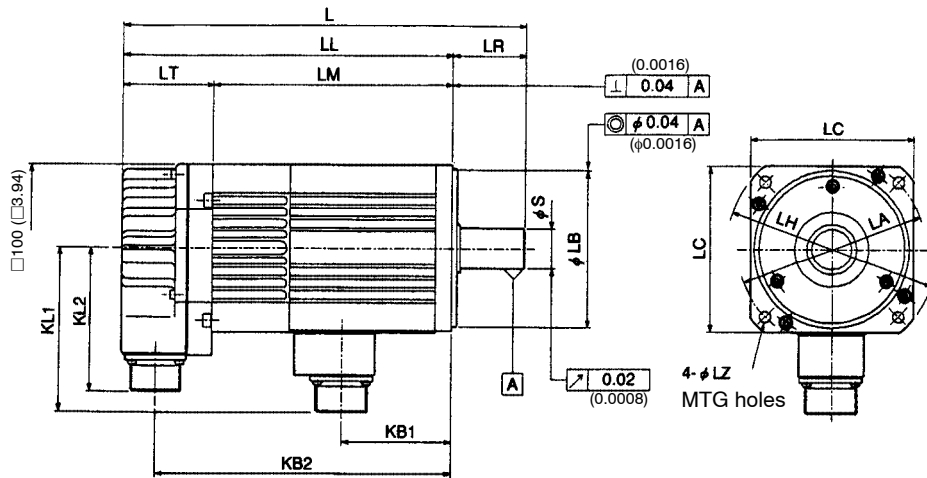

Shaft Extension

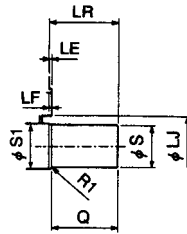

[mm (in)]

Model SGMS-	L	LL	LM	LR	LT	KB1	KB2	KL1	KL2
10ASAAB	252 (9.92)	207 (8.15)	147 (5.79)	45 (1.77)	60 (2.36)	67 (2.64)	186 (7.32)	100 (3.94)	87 (3.43)
15ASAAB	278 (10.94)	233 (9.17)	173 (6.81)	45 (1.77)	60 (2.36)	93 (3.66)	212 (8.35)	100 (3.94)	87 (3.43)
20ASAAB	301 (11.85)	256 (10.08)	196 (7.72)	45 (1.77)	60 (2.36)	116 (4.57)	235 (9.25)	100 (3.94)	87 (3.43)
30ASAAB	314 (12.36)	251 (9.88)	191 (7.52)	63 (2.48)	60 (2.36)	113 (4.45)	230 (9.06)	119 (4.69)	87 (3.43)
40ASAAB	350 (13.78)	288 (11.34)	228 (8.98)	63 (2.48)	60 (2.36)	150 (5.91)	267 (10.51)	119 (4.69)	87 (3.43)
50ASAAB	391 (15.39)	328 (12.91)	268 (10.55)	63 (2.48)	60 (2.36)	190 (7.48)	307 (12.09)	119 (4.69)	87 (3.43)

Model SGMS-	Flange Dimensions [mm (in)]									Shaft End Dimensions [mm (in)]			Approx. Mass [kg (lb)]
	LA	LB	LC	LE	LF	LG	LH	LJ	LZ	S	S1	Q	
10ASAAB	115 (4.53)	$95 \begin{matrix} 0 \\ -0.035 \\ 0 \\ (3.74 - 0.0014) \end{matrix}$	100 (3.94)	3 (0.12)	3 (0.12)	10 (0.39)	130 (5.12)	45 (1.77)	7 (0.28)	$24 \begin{matrix} 0 \\ -0.013 \\ 0 \\ (0.94 - 0.0005) \end{matrix}$	30 (1.18)	40 (1.57)	6.5 (14.3)
15ASAAB	115 (4.53)	$95 \begin{matrix} 0 \\ -0.035 \\ 0 \\ (3.74 - 0.0014) \end{matrix}$	100 (3.94)	3 (0.12)	3 (0.12)	10 (0.39)	130 (5.12)	45 (1.77)	7 (0.28)	$24 \begin{matrix} 0 \\ -0.013 \\ 0 \\ (0.94 - 0.0005) \end{matrix}$	30 (1.18)	40 (1.57)	8.0 (17.6)
20ASAAB	115 (4.53)	$95 \begin{matrix} 0 \\ -0.035 \\ 0 \\ (3.74 - 0.0014) \end{matrix}$	100 (3.94)	3 (0.12)	3 (0.12)	10 (0.39)	130 (5.12)	45 (1.77)	7 (0.28)	$24 \begin{matrix} 0 \\ -0.013 \\ 0 \\ (0.94 - 0.0005) \end{matrix}$	30 (1.18)	40 (1.57)	9.0 (19.8)
30ASAAB	145 (5.71)	$110 \begin{matrix} 0 \\ -0.035 \\ 0 \\ (4.33 - 0.0014) \end{matrix}$	130 (5.12)	6 (0.24)	6 (0.24)	12 (0.47)	165 (6.50)	45 (1.77)	9 (0.35)	$28 \begin{matrix} 0 \\ -0.013 \\ 0 \\ (1.10 - 0.0005) \end{matrix}$	30 (1.18)	55 (2.17)	14.5 (32.0)
40ASAAB	145 (5.71)	$110 \begin{matrix} 0 \\ -0.035 \\ 0 \\ (4.33 - 0.0014) \end{matrix}$	130 (5.12)	6 (0.24)	6 (0.24)	12 (0.47)	165 (6.50)	45 (1.77)	9 (0.35)	$28 \begin{matrix} 0 \\ -0.013 \\ 0 \\ (1.10 - 0.0005) \end{matrix}$	30 (1.18)	55 (2.17)	17.5 (38.6)
50ASAAB	145 (5.71)	$110 \begin{matrix} 0 \\ -0.035 \\ 0 \\ (4.33 - 0.0014) \end{matrix}$	130 (5.12)	6 (0.24)	6 (0.24)	12 (0.47)	165 (6.50)	45 (1.77)	9 (0.35)	$28 \begin{matrix} 0 \\ -0.013 \\ 0 \\ (1.10 - 0.0005) \end{matrix}$	30 (1.18)	55 (2.17)	20.5 (45.2)

Note The Encoder uses a 15-bit (8192 P/R) absolute encoder.

Connector Wiring on Servomotor End

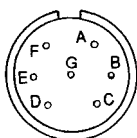

A	Phase U	E	Brake terminal
B	Phase V	F	Brake terminal
C	Phase W	G	-
D	FG (Frame Ground)		

9.1.4 SGMD-□□A Servomotors

■ Servomotors with 4096 P/R Incremental Encoders and Brakes

The external views are the same, only the approximate mass is different.

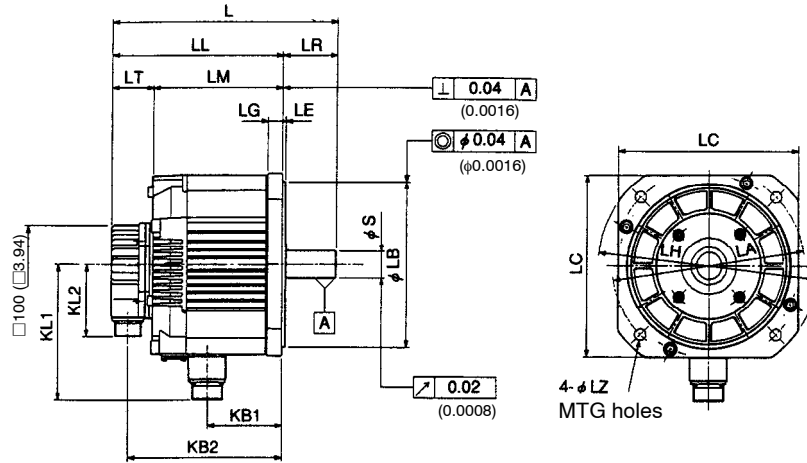

Shaft Extension

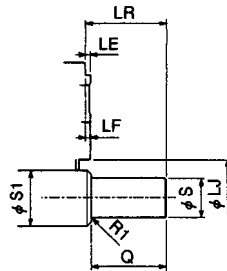

[mm (in)]

Model SGMD-	L	LL	LM	LR	LT	KB1	KB2	KL1	KL2
22A6A	242 (9.53)	187 (7.36)	144 (5.67)	55 (2.17)	43 (1.69)	70 (2.76)	166 (6.54)	165 (6.50)	88 (3.46)
32A6A	254 (10.00)	199 (7.83)	156 (6.14)	55 (2.17)	43 (1.69)	82 (3.23)	178 (7.01)	165 (6.50)	88 (3.46)
40A6A	274 (10.79)	209 (8.23)	166 (6.54)	65 (2.56)	43 (1.69)	92 (3.62)	188 (7.40)	165 (6.50)	88 (3.46)

Model SGMD-	Flange Dimensions [mm (in)]									Shaft End Dimensions [mm (in)]			Approx. Mass [kg (lb)]	
	LA	LB	LC	LE	LF	LG	LH	LJ	LZ	S	S1	Q	Without Brake	With Brake
22A6A	235 (9.25)	$200 \begin{matrix} 0 \\ -0.046 \\ 0 \\ (7.87 - 0.0018) \end{matrix}$	220 (8.66)	4 (0.16)	4 (0.16)	18 (0.71)	270 (10.63)	62 (2.44)	13.5 (0.53)	$28 \begin{matrix} 0 \\ -0.013 \\ 0 \\ (1.10 - 0.0005) \end{matrix}$	45 (1.77)	50 (1.97)	15.5 (34.172)	20.5 (45.2)
32A6A	235 (9.25)	$200 \begin{matrix} 0 \\ -0.046 \\ 0 \\ (7.87 - 0.0018) \end{matrix}$	220 (8.66)	4 (0.16)	4 (0.16)	18 (0.71)	270 (10.63)	62 (2.44)	13.5 (0.53)	$28 \begin{matrix} 0 \\ -0.013 \\ 0 \\ (1.10 - 0.0005) \end{matrix}$	45 (1.77)	50 (1.97)	18.5 (40.786)	23.5 (51.8)
40A6A	235 (9.25)	$200 \begin{matrix} 0 \\ -0.046 \\ 0 \\ (7.87 - 0.0018) \end{matrix}$	220 (8.66)	4 (0.16)	4 (0.16)	18 (0.71)	270 (10.63)	62 (2.44)	13.5 (0.53)	$32 \begin{matrix} 0 \\ -0.016 \\ 0 \\ (1.26 - 0.0006) \end{matrix}$	45 (1.77)	60 (2.36)	21 (46.297)	26 (57.3)

Note 1. The Encoder uses a 4096 P/R incremental encoder.

2. AB at the end of the model number indicates a brake.

Connector Wiring on Encoder End

Receptacle: MS3102A20-29

Plug: (To be prepared by customer) (L type): MS3108B20-29S or (Straight type)
MS3106B20-29S

Cable Clamp: (To be prepared by customer) MS3057-12A

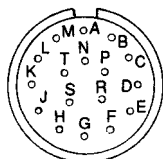

A	A Channel Output	K	-
B	\bar{A} Channel Output	L	-
C	B Channel Output	M	-
D	\bar{B} Channel Output	N	-
E	C Channel Output	P	-
F	\bar{C} Channel Output	R	-
G	0 V	S	-
H	+5 VDC	T	-
J	FG (Frame Ground)		

Note 1. Terminals K to T are not used.

2. Receptacle, plug and cable clamp are common regardless of motor capacity.

Connector Wiring on Sermomotor End

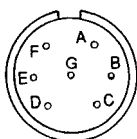

A	Phase U	E	Brake terminal
B	Phase V	F	Brake terminal
C	Phase W	G	-
D	FG (Frame Ground)		

Note E and F are blank if there is no brake.

■ Servomotors with 12-bit (1024 P/R) Absolute Encoders and Brakes

The external views are the same, only the approximate mass is different.

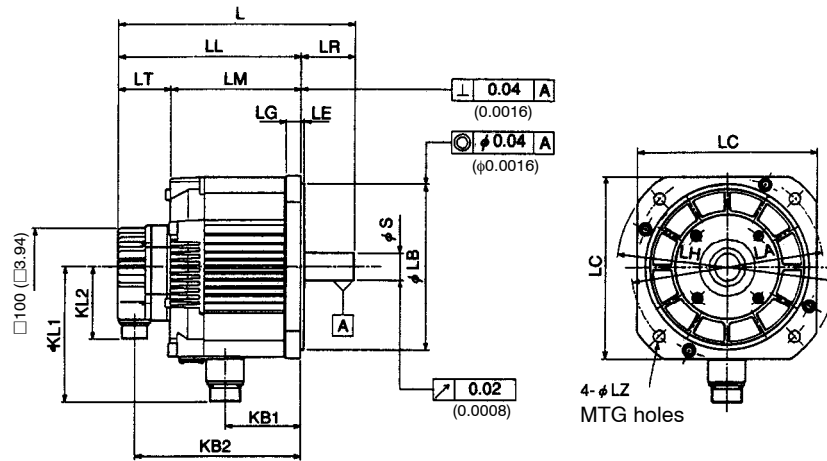

Shaft Extension

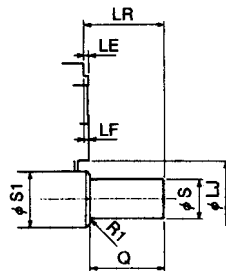

[mm (in)]

Model SGMD-	L	LL	LM	LR	LT	KB1	KB2	KL1	KL2
22AWA	256 (10.08)	201 (7.91)	144 (5.67)	55 (2.17)	57 (2.24)	70 (2.76)	180 (7.09)	165 (6.50)	88 (3.46)
32AWA	268 (10.55)	213 (8.39)	156 (6.14)	55 (2.17)	57 (2.24)	82 (3.23)	192 (7.56)	165 (6.50)	88 (3.46)
40AWA	288 (11.34)	223 (8.78)	166 (6.54)	65 (2.56)	57 (2.24)	92 (3.62)	202 (7.95)	165 (6.50)	88 (3.46)

Model SGMD-	Flange Dimensions [mm (in)]									Shaft End Dimensions [mm (in)]			Approx. Mass [kg (lb)]	
	LA	LB	LC	LE	LF	LG	LH	LJ	LZ	S	S1	Q	Without Brake	With Brake
22AWA	235 (9.25)	$200 \begin{matrix} 0 \\ -0.046 \\ 0 \\ (7.87 - 0.0018) \end{matrix}$	220 (8.66)	4 (0.16)	4 (0.16)	18 (0.71)	270 (10.63)	62 (2.44)	13.5 (0.53)	$28 \begin{matrix} 0 \\ -0.013 \\ 0 \\ (1.10 - 0.0005) \end{matrix}$	45 (1.77)	50 (1.97)	15.5 (34.172)	20.5 (45.2)
32AWA	235 (9.25)	$200 \begin{matrix} 0 \\ -0.046 \\ 0 \\ (7.87 - 0.0018) \end{matrix}$	220 (8.66)	4 (0.16)	4 (0.16)	18 (0.71)	270 (10.63)	62 (2.44)	13.5 (0.53)	$28 \begin{matrix} 0 \\ -0.013 \\ 0 \\ (1.10 - 0.0005) \end{matrix}$	45 (1.77)	50 (1.97)	18.5 (40.786)	23.5 (51.8)
40AWA	235 (9.25)	$200 \begin{matrix} 0 \\ -0.046 \\ 0 \\ (7.87 - 0.0018) \end{matrix}$	220 (8.66)	4 (0.16)	4 (0.16)	18 (0.71)	270 (10.63)	62 (2.44)	13.5 (0.53)	$32 \begin{matrix} 0 \\ -0.016 \\ 0 \\ (1.26 - 0.0006) \end{matrix}$	45 (1.77)	60 (2.36)	21 (46.297)	26.5 (58.4)

Note 1. The Encoder uses a 12-bit (1024 P/R) absolute encoder.

2. AB at the end of the model number indicates a brake.

Connector Wiring on Encoder End

Receptacle: MS3102A20-29

Plug: (To be prepared by customer) (L type): MS3108B20-29S or (Straight type)
MS3106B20-29S

Cable Clamp: (To be prepared by customer) MS3057-12A

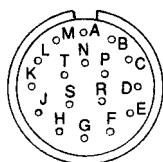

A	A Channel Output	K	S Channel Output
B	\bar{A} Channel Output	L	\bar{S} Channel Output
C	B Channel Output	M	–
D	\bar{B} Channel Output	N	–
E	Z Channel Output	P	–
F	\bar{Z} Channel Output	R	Reset
G	0 V	S	0 V (battery)
H	+5 VDC	T	3.6 V (battery)
J	FG (Frame Ground)		

Note 1. Terminals M to P are not used. Do not connect anything.

2. Receptacle, plug and cable clamp are common regardless of motor capacity.

Connector Wiring on Servomotor End

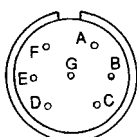

A	Phase U	E	Brake terminal
B	Phase V	F	Brake terminal
C	Phase W	G	–
D	FG (Frame Ground)		

Note E and F are blank if there is no brake.

9.1.5 SGMP-15A Servomotor

■ SGMP Servomotor

Servomotors with Incremental Encoders, without Brakes (SGMP-15A31□)

- 1.5 kW

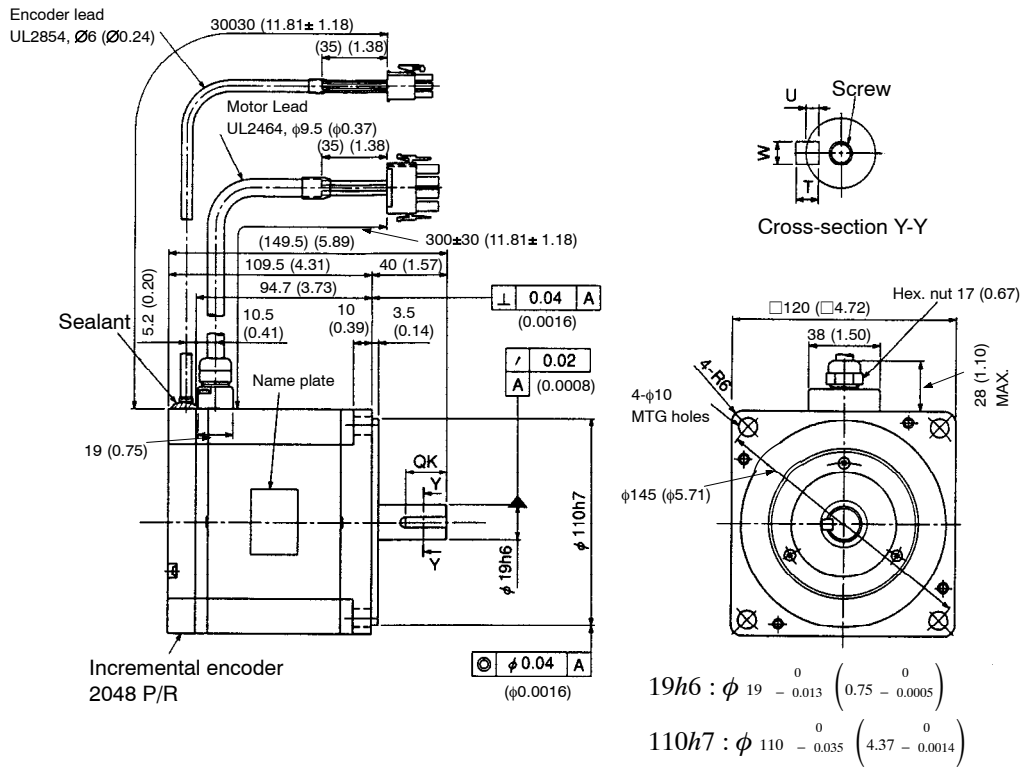

Model SGMP-	QK	U	W	T	Screw dimensions	Output W	Approx. Mass kg (lb)	Allowable Radial Load N (lbf)	Allowable Thrust Load N (lbf)
15A312	No key				—	1500	6.6 (14.6)	490 (110)	147 (33)
15A314	22 (0.87)	3.5 (0.14)	6 (0.24)	6 (0.24)	—				
15A316	22 (0.87)	3.5 (0.14)	6 (0.24)	6 (0.24)	M6, depth 10				

- Note 1.** The encoder is a 2048 P/R incremental encoder.
- “A” in the model number indicates 200 V specification.
 - SGMP-15A314 and 15A316 have keyed shafts. The keyway complies with JIS B 1301-1976 (precision), and a straight key is provided.
 - The quoted allowable radial load is the value at a position 35 mm (1.38 in) from the motor mounting surface.

Servomotor and Encoder Plug

Motor Plug

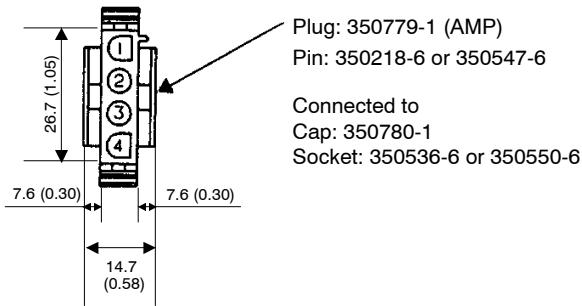

Motor Wiring Specifications

1	Phase U	Red
2	Phase V	White
3	Phase W	Blue
4	FG	Green, Yellow

Encoder Plug

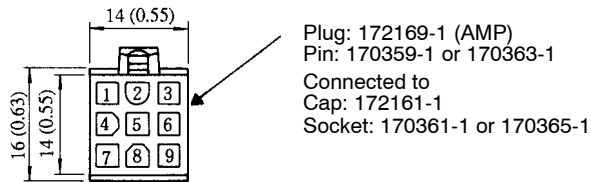

Incremental Encoder Wiring Specifications

1	A channel output	Blue
2	\bar{A} channel output	Blue, Black
3	B channel output	Yellow
4	\bar{B} channel output	Yellow, Black
5	C channel output	Green
6	\bar{C} channel output	Green, Black
7	0 V (power supply)	Gray
8	+5 V (power supply)	Red
9	FG (Frame Ground)	Orange



■ SGMP Servomotors

Servomotors with Incremental Encoders and Brakes
(SGMP-15A31□B, C)

● 1.5 kW

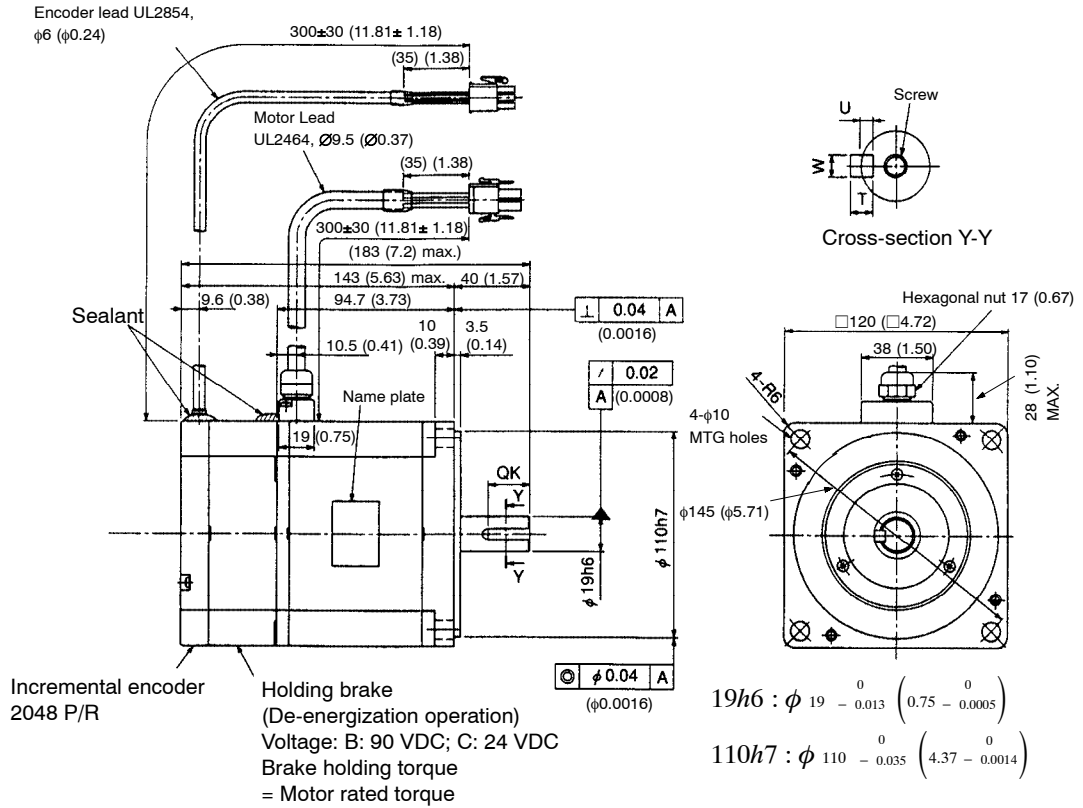

Model SGMP-	QK	U	W	T	Screw dimensions	Output W	Approx. Mass kg (lb)	Allowable Radial Load N (lbf)	Allowable Thrust Load N (lbf)
15A312B	No key				-	1500	8.1 (17.9)	490 (110)	147 (33)
15A312C									
15A314B	22	3.5	6	6	-	1500	8.1 (17.9)	490 (110)	147 (33)
15A314C	(0.87)	(0.14)	(0.24)	(0.24)					
15A316B	22	3.5	6	6	M6,	1500	8.1 (17.9)	490 (110)	147 (33)
15A316C	(0.87)	(0.14)	(0.24)	(0.24)	depth 10				

Note 1. The encoder is a 2048 P/R incremental encoder.

- "A" in the model number indicates 200 V specification.
- SGMP-15A314B(C) and 15A316B(C) have keyed shafts. The keyway complies with JIS B 1301-1976 (precision), and a straight key is provided.
- The quoted allowable radial load is the value at a position 35 mm (1.38 in) from the motor mounting surface.
- The electromagnetic brake is only used to hold the load in position and cannot be used to stop the motor.

Servomotor and Encoder Plug

Motor Plug

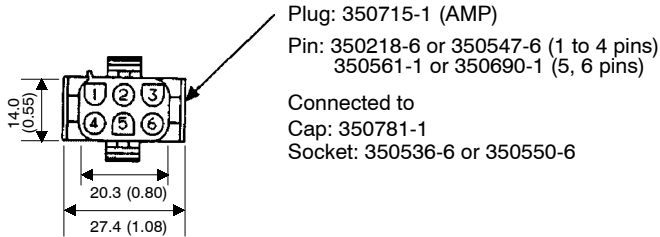

Motor Wiring Specifications

1	Phase U	Red
2	Phase V	White
3	Phase W	Blue
4	FG	Green, Yellow
5	Brake terminal	Black
6	Brake terminal	Black

Encoder Plug

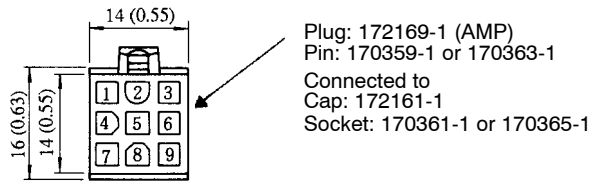

Incremental Encoder Wiring Specifications

1	A channel output	Blue
2	\bar{A} channel output	Blue, Black
3	B channel output	Yellow
4	\bar{B} channel output	Yellow, Black
5	C channel output	Green
6	\bar{C} channel output	Green, Black
7	0 V (power supply)	Gray
8	+5 V (power supply)	Red
9	FG (Frame Ground)	Orange

■ SGMP Servomotors

Servomotors with Absolute Encoders, without Brakes
(SGMP-15AW□□)

- 1.5 kW

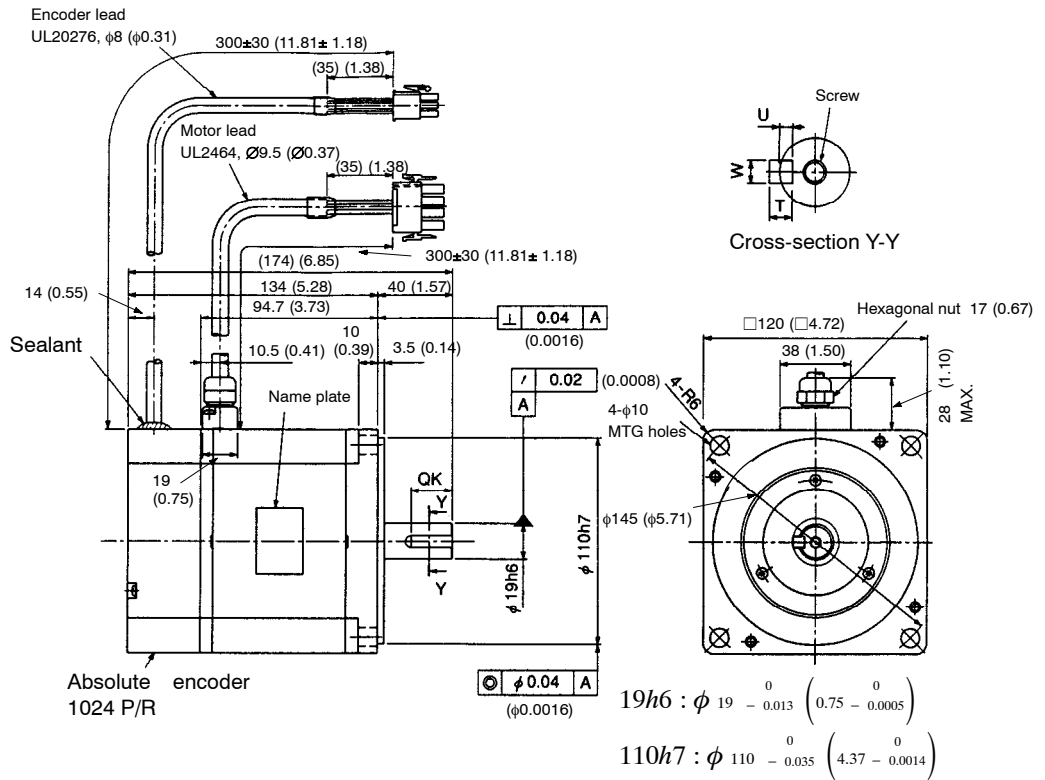

Model SGMP-	QK	U	W	T	Screw dimensions	Output W	Approx. Mass kg (lb)	Allowable Radial Load N (lbf)	Allowable Thrust Load N (lbf)
15AW12	No key				—	1500	7.1 (15.7)	490 (110)	147 (33)
15AW14	22 (0.87)	3.5 (0.14)	6 (0.24)	6 (0.24)	—				
15AW16	22 (0.87)	3.5 (0.14)	6 (0.24)	6 (0.24)	M6, depth 10				

- Note 1.** The encoder is a 1024 P/R, 12-bit absolute encoder.
- “A” in the model number indicates 200 V-specification.
 - SGMP-15A314B(C) and 15A316B(C) have keyed shafts. The keyway complies with JIS B 1301-1976 (precision), and a straight key is provided.
 - The quoted allowable radial load is the value at a position 35 mm (1.38 in) from the motor mounting surface.

Servomotor and Encoder Plug

Motor Plug

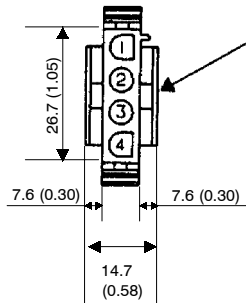

Plug: 350779-1 (AMP)
 Pin: 350218-6 or 350547-6
 Connected to
 Cap: 350780-1
 Socket: 350536-6 or 350550-6

Motor Wiring Specifications

1	Phase U	Red
2	Phase V	White
3	Phase W	Blue
4	FG	Green, Yellow

Encoder Plug

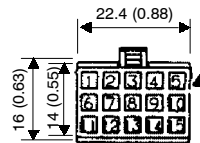

Plug: 172171-1 (AMP)
 Pin: 170359-1 or 170363-1
 Connected to
 Cap: 172163-1
 Socket: 170361-1 or 170365-1

Absolute Encoder Wiring Specifications

1	A channel output	Blue
2	\bar{A} channel output	White, Blue
3	B channel output	Yellow
4	\bar{B} channel output	White, Yellow
5	Z (C) channel output	Green
6	\bar{Z} (\bar{C}) channel output	White, Green
7	0 V (power supply)	Black
8	+5 V (power supply)	Red
9	FG (Frame Ground)	Green, Yellow
10	S channel output	Purple
11	\bar{S} channel output	White, Purple
(12)*	(Capacitor reset)	(Gray)
13	Reset	White, Gray
14	0 V (battery)	White, Orange
15	3.6V (battery)	Orange

* Terminal to discharge capacitor before shipment. Do not use.

■ SGMP Servomotors

SGMP-15AW□□B, C Servomotors with Absolute Encoders and Brakes

- 1.5 kW

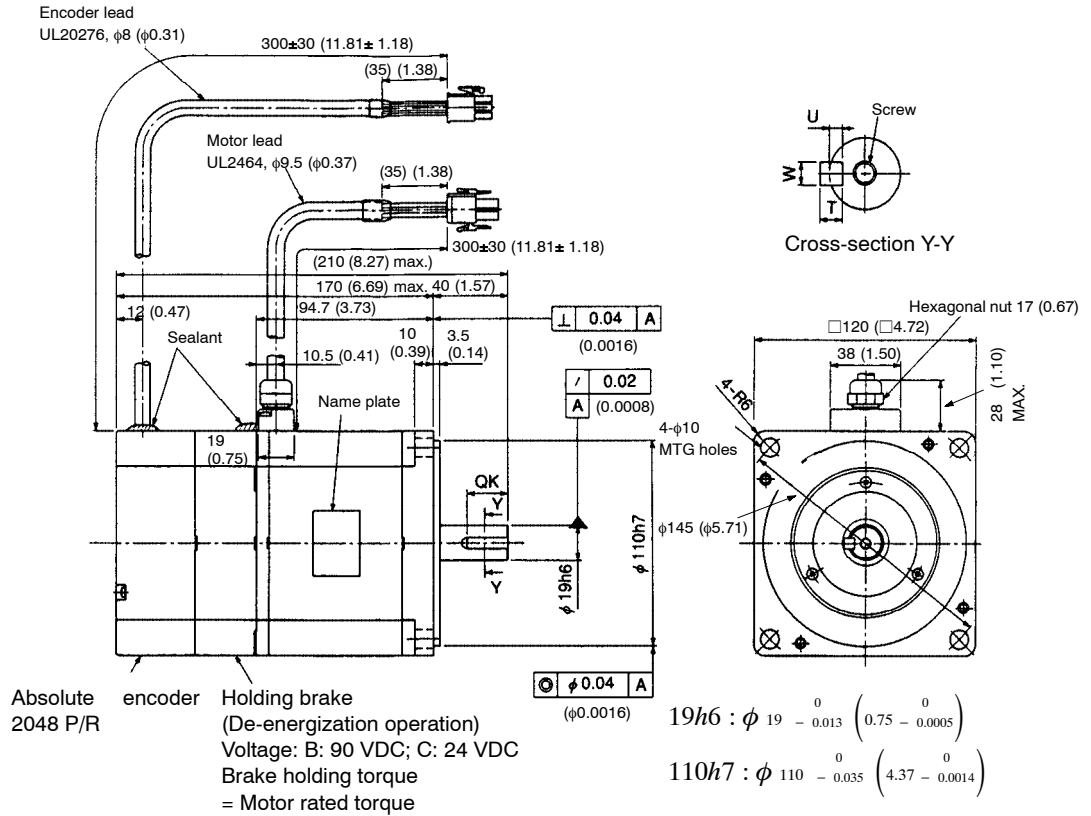

Model SGMP-	QK	U	W	T	Screw dimensions	Output W	Approx. Mass kg (lb)	Allowable Radial Load N (lbf)	Allowable Thrust Load N (lbf)
15AW12B	No key				-	1500	8.6 (19.0)	490 (110)	147 (33)
15AW12C									
15AW14B	22 (0.87)	3.5 (0.14)	6 (0.24)	6 (0.24)	-				
15AW14C									
15AW16B	22 (0.87)	3.5 (0.14)	6 (0.24)	6 (0.24)	M6, depth 10				
15AW16C									

- Note 1.** The encoder is a 1024 P/R, 12-bit absolute encoder.
- “A” in the model number indicates 200 V-specification.
 - SGMP-15A314B(C) and 15A316B(C) have keyed shafts. The keyway complies with JIS B 1301-1976 (precision), and a straight key is provided.
 - The quoted allowable radial load is the value at a position 35 mm (1.38 in) from the motor mounting surface.
 - The electromagnetic brake is only used to hold the load in position and cannot be used to stop the motor.

Servomotor and Encoder Plug

Motor Plug

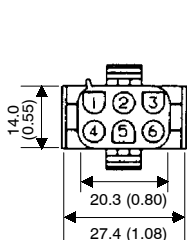

Plug: 350715-1 (AMP)
Pin: 350218-6 or 350547-6 (1 to 4 pins)
350561-1 or 350690-1 (5, 6 pins)

Connected to
Cap: 350781-1
Socket: 350536-6 or 350550-6

Encoder Plug

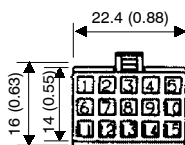

Plug: 172171-1 (AMP)
Pin: 170359-1 or 170363-1

Connected to
Cap: 172163-1
Socket: 170361-1 or 170365-1

Motor Wiring Specifications

1	Phase U	Red
2	Phase V	White
3	Phase W	Blue
4	FG	Green, Yellow
5	Brake terminal	Black
6	Brake terminal	Black

Absolute Encoder Wiring Specifications

1	A channel output	Blue
2	\bar{A} channel output	White, Blue
3	B channel output	Yellow
4	\bar{B} channel output	White, Yellow
5	Z (C) channel output	Green
6	\bar{Z} (\bar{C}) channel output	White, Green
7	0 V (power supply)	Black
8	+5 V (power supply)	Red
9	FG (Frame Ground)	Green, Yellow
10	S channel output	Purple
11	\bar{S} channel output	White, Purple
(12)*	(Capacitor reset)	(Gray)
13	Reset	White, Gray
14	0 V (battery)	White, Orange
15	3.6 V (battery)	Orange

* Terminal to discharge capacitor before shipment. Do not use.

9.1.6 List of Encoder and Servomotor End Connectors

■ Standard Connectors (Not IP67 Compatible)

List of SGM□ Servomotor Connectors (Standard: Without Holding Brake)

Servomotor Model	Servomotor End Connector			
	Receptacle	L-shaped Plug	Straight Plug	Cable Clamp
SGMS- 10A□A 15A□A 20A□A 30A□A 40A□A 50A□A	MS3102A18-10P	MS3108B18-10S	MS3106B18-10S	MS3057-10A
	MS3102A22-22P	MS3108B22-22S	MS3106B22-22S	MS3057-12A
	MS3102A18-10P	MS3108B18-10S	MS3106B18-10S	MS3057-10A
	MS3102A22-22P	MS3108B22-22S	MS3106B22-22S	MS3057-12A
	MS3102A32-17P	MS3108B32-17S	MS3106B32-17S	MS3057-20A
SGMG- 05A□A 09A□A 13A□A 20A□A 30A□A 44A□A 55A□A 75A□A 1AA□A 1EA□A	MS3102A18-10P	MS3108B18-10S	MS3106B18-10S	MS3057-10A
	MS3102A22-22P	MS3108B22-22S	MS3106B22-22S	MS3057-12A
	MS3102A32-17P	MS3108B32-17S	MS3106B32-17S	MS3057-20A
	MS3102A18-10P	MS3108B18-10S	MS3106B18-10S	MS3057-10A
	MS3102A22-22P	MS3108B22-22S	MS3106B22-22S	MS3057-12A
SGMG- 03A□B 06A□B 09A□B 12A□B 20A□B 30A□B 44A□B 60A□B	MS3102A18-10P	MS3108B18-10S	MS3106B18-10S	MS3057-10A
	MS3102A22-22P	MS3108B22-22S	MS3106B22-22S	MS3057-12A
	MS3102A32-17P	MS3108B32-17S	MS3106B32-17S	MS3057-20A
	MS3102A24-10P	MS3108B24-10S	MS3106B24-10S	MS3057-16A
SGMD- 22A□A 32A□A 40A□A	MS3102A24-10P	MS3108B24-10S	MS3106B24-10S	MS3057-16A

Connector on motor end already provided.

Provided by the user.

Servomotor Model	Encoder End Connector			
	Receptacle	L-shaped Plug	Straight Plug	Cable Clamp
SGMS- 10A <input type="checkbox"/> A 15A <input type="checkbox"/> A 20A <input type="checkbox"/> A 30A <input type="checkbox"/> A 40A <input type="checkbox"/> A 50A <input type="checkbox"/> A	MS3102A20-29P	MS3108B20-29S	MS3106B20-29S	MS3057-12A
SGMG- 05A <input type="checkbox"/> A 09A <input type="checkbox"/> A 13A <input type="checkbox"/> A 20A <input type="checkbox"/> A 30A <input type="checkbox"/> A 44A <input type="checkbox"/> A 55A <input type="checkbox"/> A 75A <input type="checkbox"/> A 1A <input type="checkbox"/> A 1EA <input type="checkbox"/> A	MS3102A20-29P	MS3108B20-29S	MS3106B20-29S	MS3057-12A
SGMG- 03A <input type="checkbox"/> B 06A <input type="checkbox"/> B 09A <input type="checkbox"/> B 12A <input type="checkbox"/> B 20A <input type="checkbox"/> B 30A <input type="checkbox"/> B 44A <input type="checkbox"/> B 60A <input type="checkbox"/> B	MS3102A20-29P	MS3108B20-29S	MS3106B20-29S	MS3057-12A
SGMD- 22A <input type="checkbox"/> A 32A <input type="checkbox"/> A 40A <input type="checkbox"/> A	MS3102A20-29P	MS3108B20-29S	MS3106B20-29S	MS3057-12A

Connector on motor end already provided.

Provided by the user.

List of SGM□ Servomotor Connectors (with Holding Brake)

Servomotor Model	Servomotor End Connector			
	Receptacle	L-shaped Plug	Straight Plug	Cable Clamp
SGMS- 10A□A 15A□A 20A□A	MS3102A20-15P	MS3108B20-15S	MS3106B20-15S	MS3057-12A
30A□A 40A□A 50A□A	MS3102A24-10P	MS3108B24-10S	MS3106B24-10S	MS3057-16A
SGMG- 05A□A 09A□A 13A□A	MS3102A20-15P	MS3108B20-15S	MS3106B20-15S	MS3057-12A
20A□A 30A□A 44A□A	MS3102A24-10P	MS3108B24-10S	MS3106B24-10S	MS3057-16A
55A□A 75A□A 1AA□A 1EA□A	MS3102A32-17P MS3102A10SL-3P	MS3108B32-17S MS3108B10SL-3S	MS3106B32-17S MS3106A10SL-3S	MS3057-20A MS3057-4A
SGMG- 03A□B 06A□B 09A□B	MS3102A20-15P	MS3108B20-15S	MS3106B20-15S	MS3057-12A
12A□B 20A□B 30A□B	MS3102A24-10P	MS3108B24-10S	MS3106B24-10S	MS3057-16A
44A□B 60A□B	MS3102A32-17P MS3102A10SL-3P	MS3108B32-17S MS3108B10SL-3S	MS3106B32-17S MS3106A10SL-3S	MS3057-20A MS3057-4A
SGMD- 22A□A 32A□A 40A□A	MS3102A24-10P	MS3108B24-10S	MS3106B24-10S	MS3057-16A

Connector on motor end already provided.

Provided by the user.

Note When two models are listed, the top connector model is for the Servomotor and the bottom connector model is for the brake.

Servomotor Model	Servomotor End Connector			
	Receptacle	L-shaped Plug	Straight Plug	Cable Clamp
SGMS- 10A <input type="checkbox"/> A 15A <input type="checkbox"/> A 20A <input type="checkbox"/> A 30A <input type="checkbox"/> A 40A <input type="checkbox"/> A 50A <input type="checkbox"/> A	MS3102A20-29P	MS3108B20-29S	MS3106B20-29S	MS3057-12A
SGMG- 05A <input type="checkbox"/> A 09A <input type="checkbox"/> A 13A <input type="checkbox"/> A 20A <input type="checkbox"/> A 30A <input type="checkbox"/> A 44A <input type="checkbox"/> A 55A <input type="checkbox"/> A 75A <input type="checkbox"/> A 1A <input type="checkbox"/> A 1EA <input type="checkbox"/> A	MS3102A20-29P	MS3108B20-29S	MS3106B20-29S	MS3057-12A
SGMG- 03A <input type="checkbox"/> B 06A <input type="checkbox"/> B 09A <input type="checkbox"/> B 12A <input type="checkbox"/> B 20A <input type="checkbox"/> B 30A <input type="checkbox"/> B 44A <input type="checkbox"/> B 60A <input type="checkbox"/> B	MS3102A20-29P	MS3108B20-29S	MS3106B20-29S	MS3057-12A
SGMD- 22A <input type="checkbox"/> A 32A <input type="checkbox"/> A 40A <input type="checkbox"/> A	MS3102A20-29P	MS3108B20-29S	MS3106B20-29S	MS3057-12A

Connector on motor end already provided.

Provided by the user.

■ IP67-compatible Connectors

List of SGM□ Servomotor Connectors (without Holding Brake, IP67-compatible)

Servomotor Model	Receptacle	Plug	End Bell: Japan Aviation Electronics Industry, Ltd. Back Shell: Daiichi Denshi Kogyo Co., Ltd.		Cable Clamp	Manufacturer
			Angled (L-shaped)	Straight		
For Servomotors						
SGMS- 10A□A 15A□A 20A□A	CE05-2A18-10PD	MS3106A18-10S(D190)	CE-18BA-S	CE02-18BS-S	CE3057-10A-*	Daiichi Denshi Kogyo Co., Ltd.
30A□A 40A□A 50A□A	JL04HV-2E22-22P E-B	JL04-6A22-22S	JL04-22EBL	JL04-22EB	JL04-2022CK (14)	Japan Aviation Electronics Industry Co., Ltd.
SGMG- 05A□A 09A□A 13A□A	CE05-2A18-10PD	MS3106A18-10S(D190)	CE-18BA-S	CE02-18BS-S	CE3057-10A-*	Daiichi Denshi Kogyo Co., Ltd.
20A□A 30A□A 44A□A	JL04HV-2E22-22P E-B	JL04-6A22-22S	JL04-22EBL	JL04-22EB	JL04-2022CK (14)	Japan Aviation Electronics Industry Co., Ltd.
55A□A 75A□A 1AA□A 1EA□A	JL04V-2E32-17PE-B	JL04V-6A32-17SE	*1	*1	*1	Japan Aviation Electronics Industry Co., Ltd.
SGMG- 03A□B 06A□B 09A□B	CE05-2A18-10PD	MS3106A18-10S(D190)	CE-18BA-S	CE02-18BS-S	CE3057-10A-*	Daiichi Denshi Kogyo Co., Ltd.
12A□B 20A□B 30A□B	JL04HV-2E22-22P E-B	JL04-6A22-22S	JL04-22EBL	JL04-22EB	JL04-2022CK (14)	Japan Aviation Electronics Industry Co., Ltd.
44A□B 60A□B	JL04V-2E32-17PE-B	JL04V-6A32-17SE	*1	*1	*1	Japan Aviation Electronics Industry Co., Ltd.
SGMD- 22A□A 32A□A 40A□A	JL04V-2E24-10PE-B	JL04-6A24-10S	JL04-24EBL	JL04-24EB	JL04-2428CK (17)	Japan Aviation Electronics Industry Co., Ltd.
For Encoders	97F3102E20-29P	MS3106A20-29S(D190)	CE-20BA-S	CE02-20BS-S	CE3057-12A-*	Daiichi Denshi Kogyo Co., Ltd.

Provided by the user.

* 1. Use flexible conduit for the motor section of SGMG-55A□A, -75A□A, -1AA□A, -44A□B and -60A□B Servomotors because they do not have end bells. (Japan Aviation Electronics Industry Co., Ltd.)

Note 1. Encoder connectors are the same for all Servomotor models.

2. Do not modify the receptacle and plug kits in order to conform to IP67 specifications.

3. End Bell is the name of a product manufactured by Japan Aviation Electronics Industry, Ltd., and Back Shell is the name of a product manufactured by Daiichi Denshi Kogyo Co., Ltd.
4. Select cable clamps marked with an asterisk (*) based on wire diameter.

List of SGM□ Servomotor Connectors (with Holding Brake, IP67-compatible)

Servomotor Model	Receptacle	Plug	End Bell: Japan Aviation Electronics Industry, Ltd. Back Shell: Daiichi Denshi Kogyo Co., Ltd.		Cable Clamp	Manufacturer
			Angled (L-shaped)	Straight		
For Servomotors						
SGMS- 10A□A 15A□A 20A□A 30A□A 40A□A 50A□A	CE05-2A18-10PD	MS3106A18-10S(D190)	CE-18BA-S	CE02-18BS-S	CE3057-10A-*	Daiichi Denshi Kogyo Co., Ltd.
	JL04HV-2E22-22P E-B	JL04-6A22-22S	JL04-22EBL	JL04-22EB	JL04-2022CK (14)	Japan Aviation Electronics Industry Co., Ltd.
SGMG- 05A□A 09A□A 13A□A 20A□A 30A□A 44A□A 55A□A 75A□A 1AA□A 1EA□A	CE05-2A18-10PD	MS3106A18-10S(D190)	CE-18BA-S	CE02-18BS-S	CE3057-10A-*	Daiichi Denshi Kogyo Co., Ltd.
	JL04HV-2E22-22P E-B	JL04-6A22-22S	JL04-22EBL	JL04-22EB	JL04-2022CK (14)	Japan Aviation Electronics Industry Co., Ltd.
	JL04V-2E32-17PE-B	JL04V-6A32-17SE	*1	*1	*1	Japan Aviation Electronics Industry Co., Ltd.
SGMG- 03A□B 06A□B 09A□B 12A□B 20A□B 30A□B 44A□B 60A□B	CE05-2A18-10PD	MS3106A18-10S(D190)	CE-18BA-S	CE02-18BS-S	CE3057-10A-*	Daiichi Denshi Kogyo Co., Ltd.
	JL04HV-2E22-22P E-B	JL04-6A22-22S	JL04-22EBL	JL04-22EB	JL04-2022CK (14)	Japan Aviation Electronics Industry Co., Ltd.
	JL04V-2E32-17PE-B	JL04V-6A32-17SE	*1	*1	*1	Japan Aviation Electronics Industry Co., Ltd.
SGMD- 22A□A 32A□A 40A□A	JL04V-2E24-10PE-B	JL04-6A24-10S	JL04-24EBL	JL04-24EB	JL04-2428CK (17)	Japan Aviation Electronics Industry Co., Ltd.
For Encoders	97F3102E20-29P	MS3106A20-29S(D190)	CE-20BA-S	CE02-20BS-S	CE3057-12A-*	Daiichi Denshi Kogyo Co., Ltd.

Provided by the user.

- * 1. Use flexible conduit for the motor section of SGMG-55A□A, -75A□A, -1AA□A, -44A□B and -60A□B Servomotors because they do not have end bells. (Japan Aviation Electronics Industry Co., Ltd.)

9.1.6 List of Encoder and Servomotor End Connectors

- Note 1.** Encoder connectors are the same for all Servomotor models.
2. Do not modify the receptacle and plug kits in order to conform to IP67 specifications.
 3. End Bell is the name of a product manufactured by Japan Aviation Electronics Industry, Ltd., and Back Shell is the name of a product manufactured by Daiichi Denshi Kogyo Co., Ltd.
 4. Select cable clamps marked with an asterisk (*) based on wire diameter.

9.2 SERVOPACKS

9.2.1 SGDB-05AN□ to 15AN□ SERVOPACKS (0.5 to 1.5 kW)

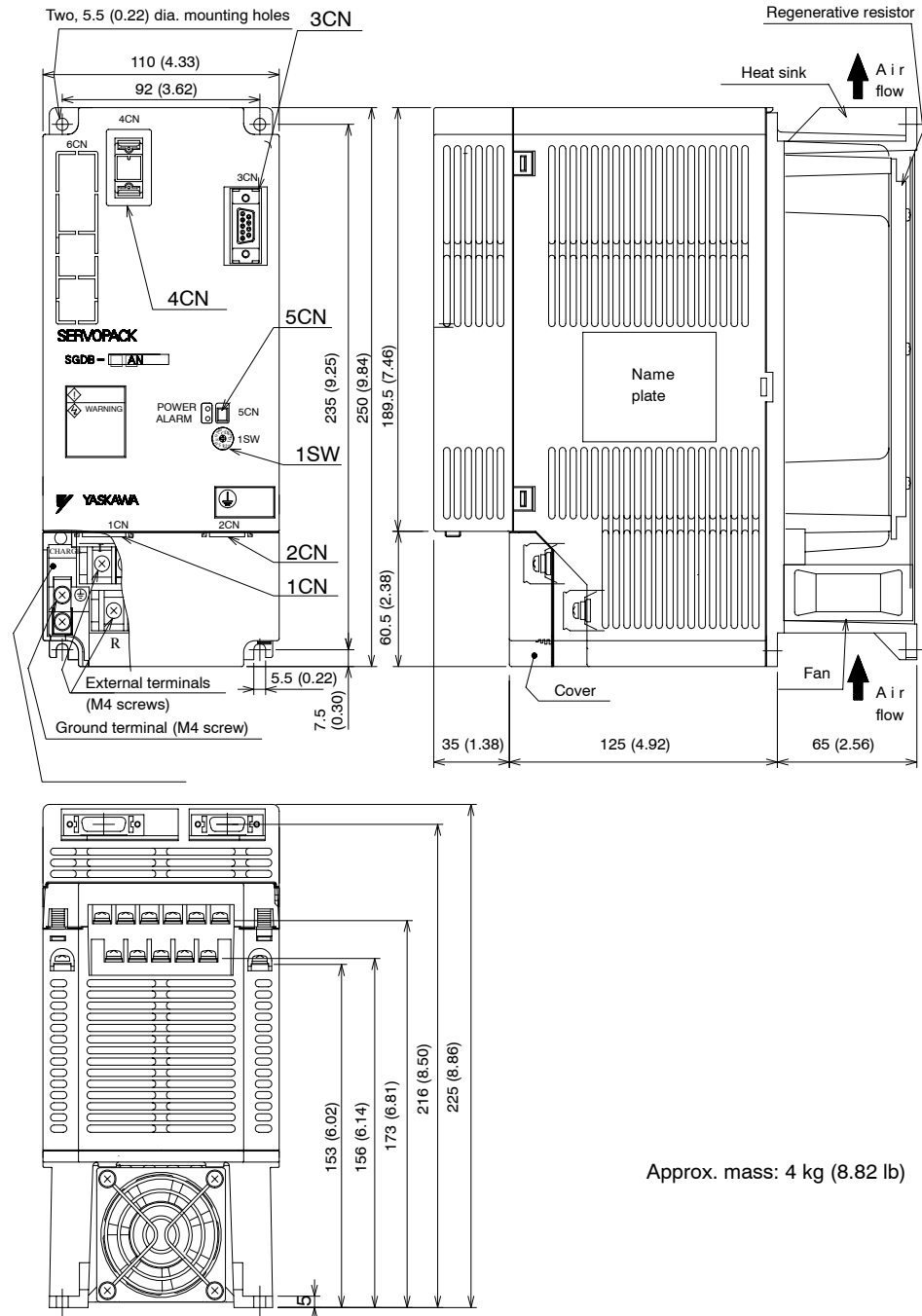

Approx. mass: 4 kg (8.82 lb)

9.2.2 SGDB-20AN□ to 30AN□ SERVOPACKS (2.0 to 3.0 kW)

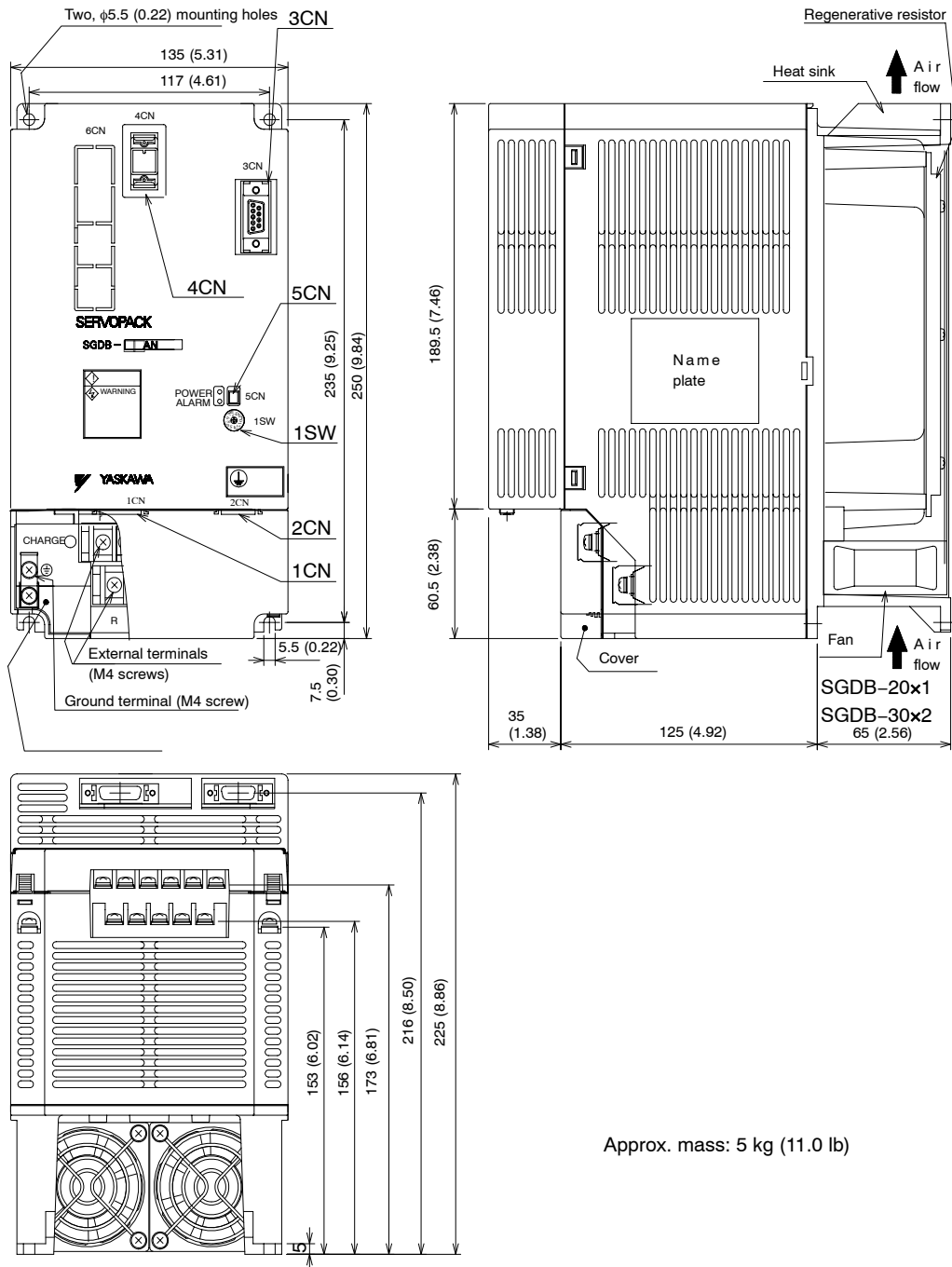

Approx. mass: 5 kg (11.0 lb)

9.2.3 SGDB-50AN □ SERVOPACKS (5.0 kW)

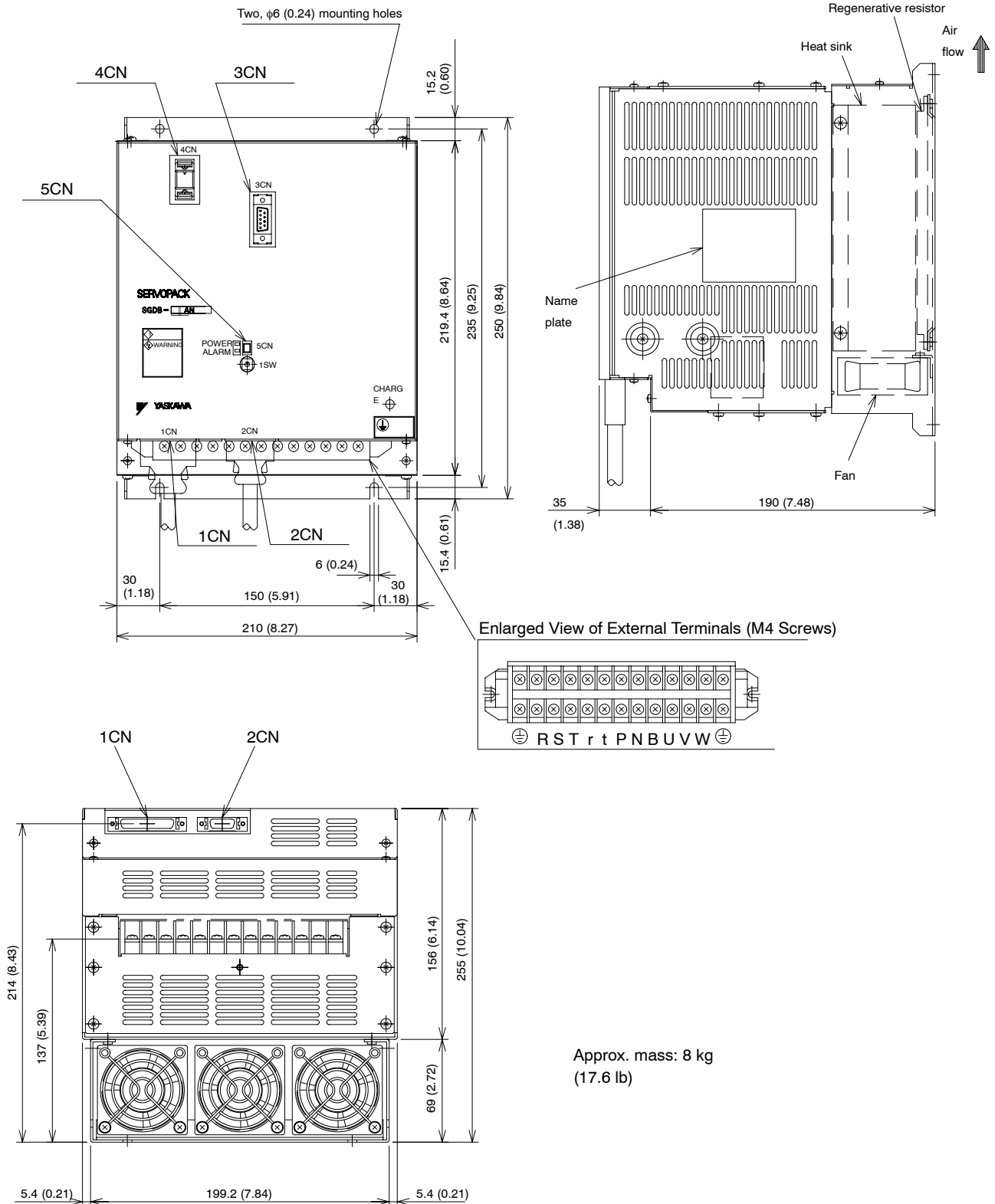

9.2.4 SGDB-60AN to 75AN SERVOPACKS (6.0 to 7.5 kW)

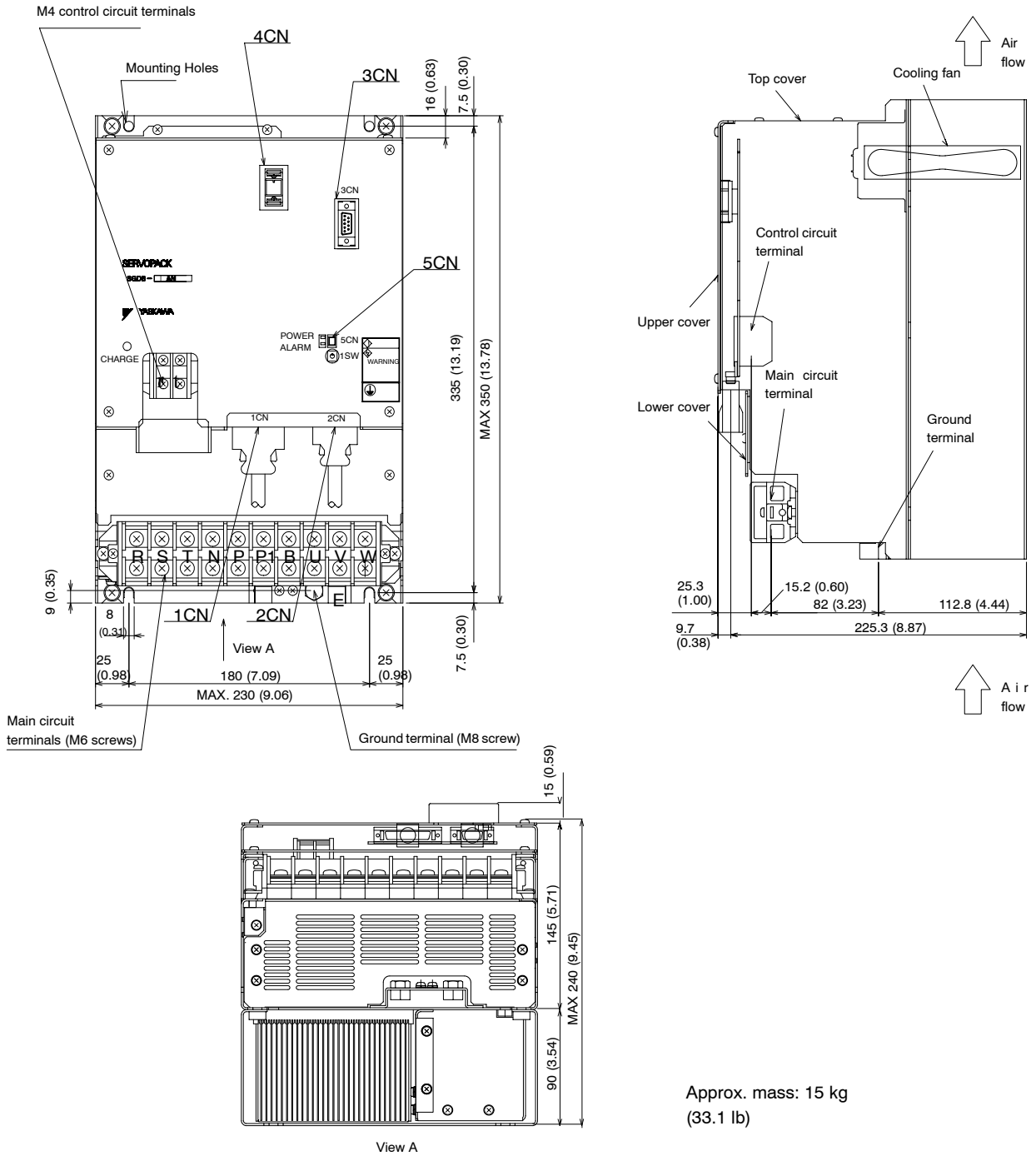

Approx. mass: 15 kg
(33.1 lb)

9.2.5 SGDB-1AAN, -1EAN SERVOPACKS (11, 15 kW)

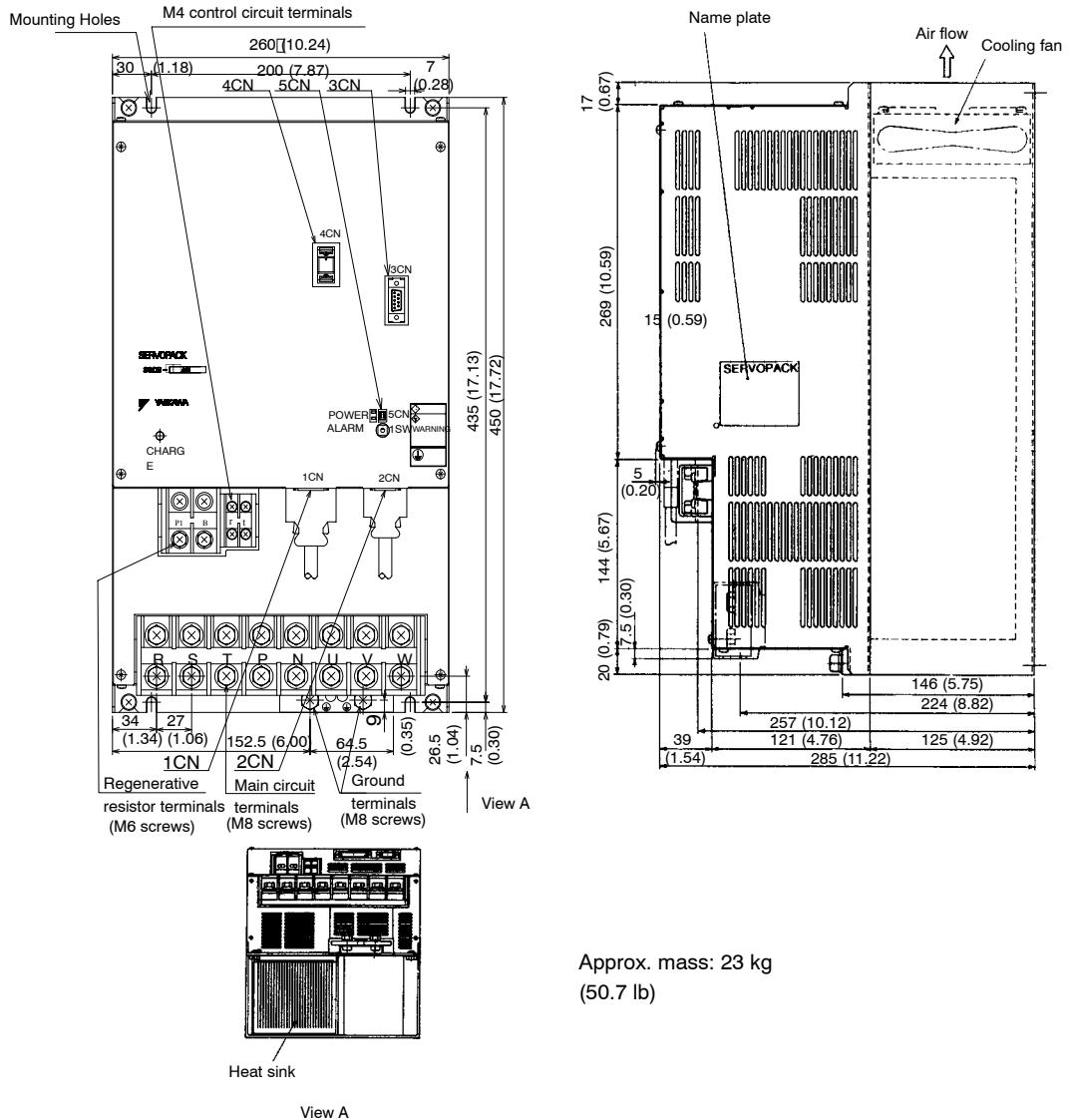

Common for SGDB-05 to 1EAN SERVOPACKS

Code	SERVOPACK End Connector	Comments
1CN	10226-52A2JL	Manufactured by Sumitomo 3M Co., Ltd.
2CN	10220-52A2JL	
4CN	MR-8RF1D2(G)	Manufactured by Honda Tsushin Kogyo Co., Ltd.
5CN	DF11-4DP-2DSA	Manufactured by Hirose Electric Co., Ltd.

We provide duct ventilation SERVOPACKS with an externally mounted heat sink, and the following advantages are offered by this mounting method.

- Reduces temperature rise in the controller by radiating internal SERVOPACK heat outside.
- Minimizes the size of the controller and ensures reliability.

9.2.6 SGDB-05AN□-P to 15AN□-P SERVOPACKS

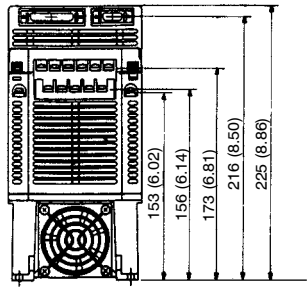
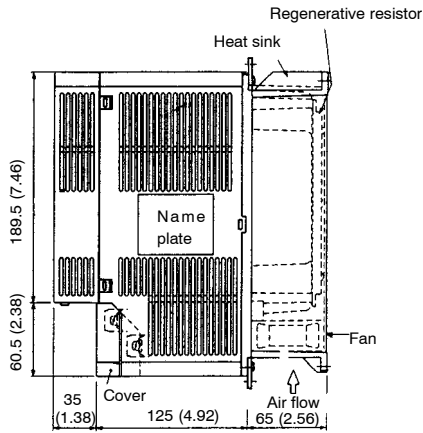
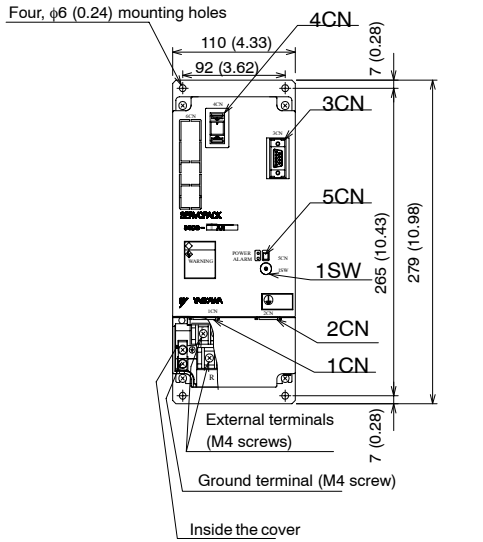

Approx. mass: 4 kg (8.82 lb)

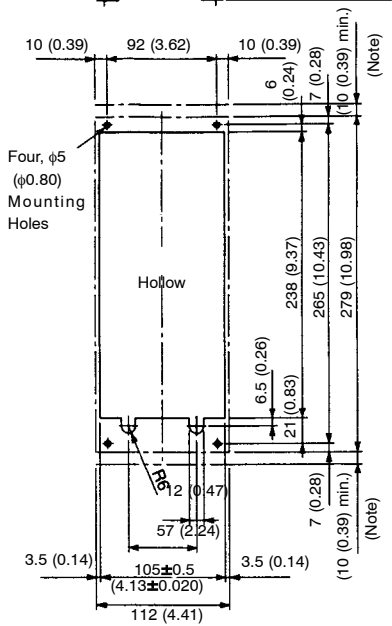

View of the Mounting Surface

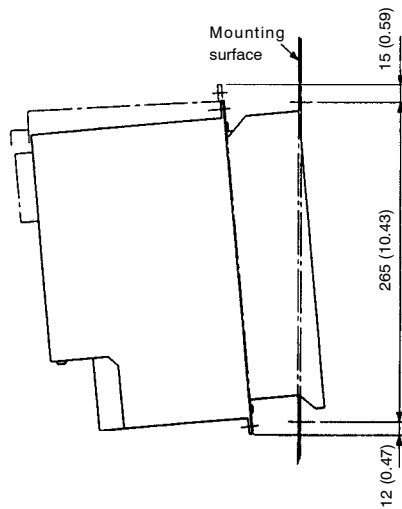

Note The angle shown in the diagram above is required for mounting. Maintain a gap at least 10 mm (0.39 in) wide at the top and bottom.

9.2.7 SGDB-20AN□-P to 30AN□-P SERVOPACKS

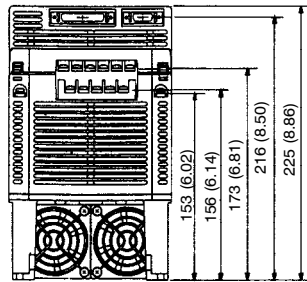
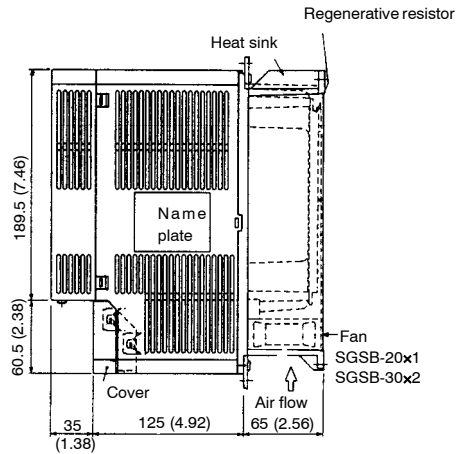
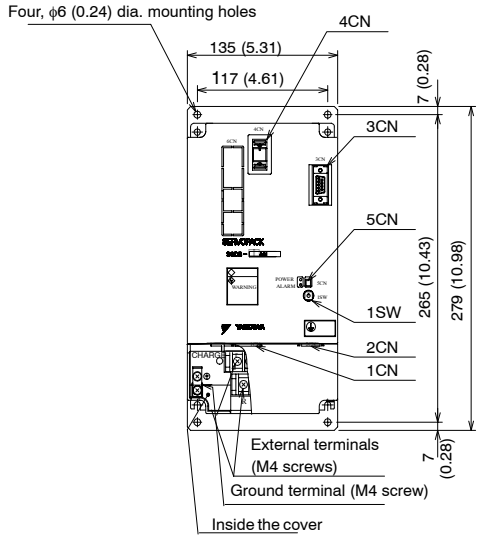

Approx. mass: 5 kg (11.0 lb)

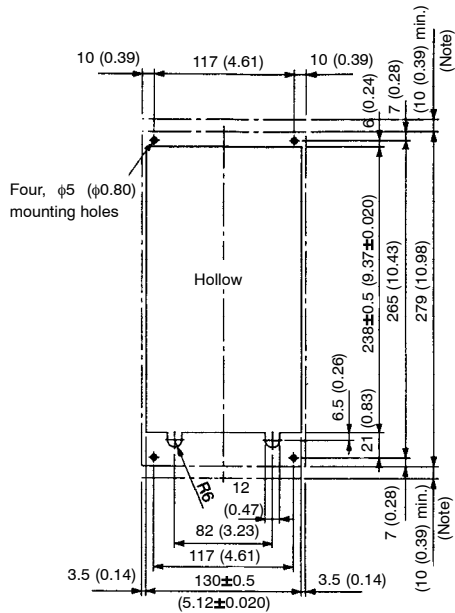

View of the Mounting Surface

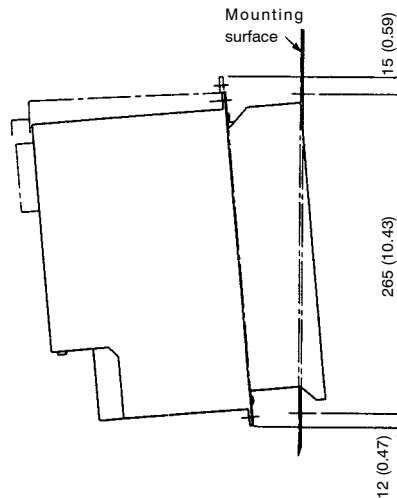

Note The angle shown in the diagram above is required for mounting. Maintain a gap at least 10 mm (0.39 in) wide at the top and bottom.

9.2.8 SGDB-50AN□-P SERVOPACK

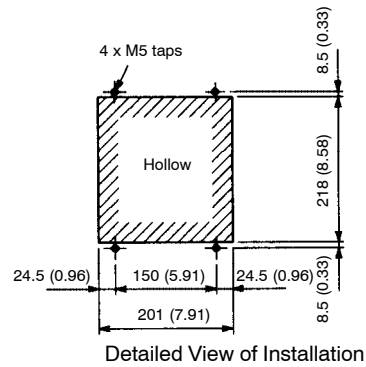
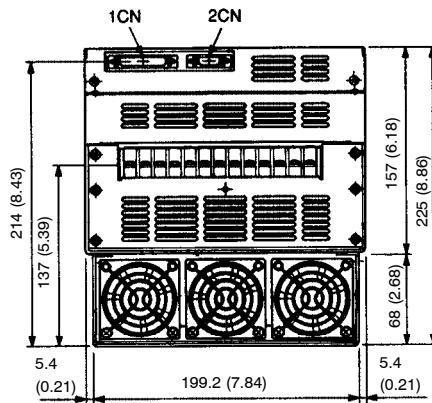
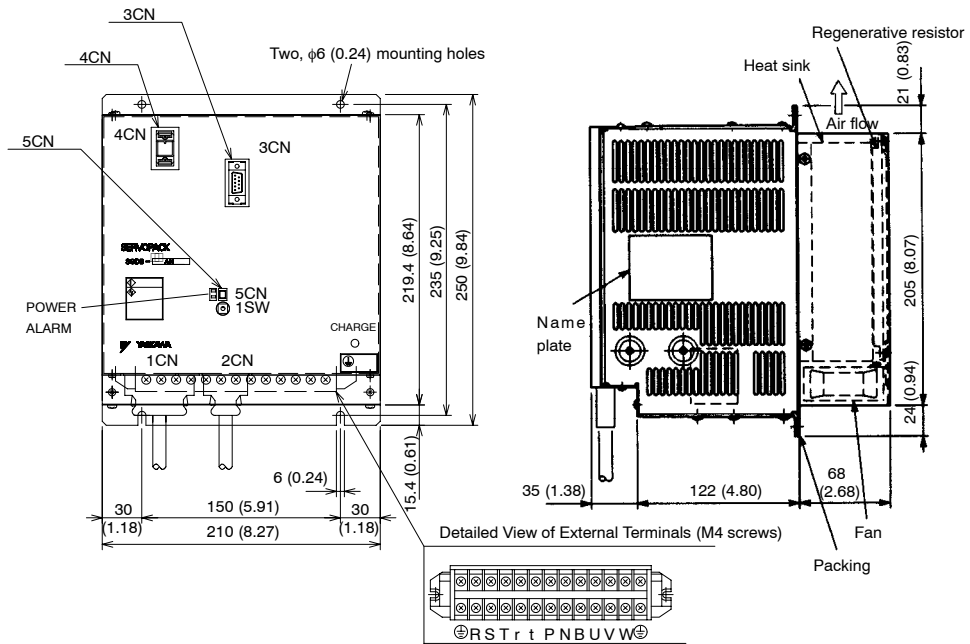

Approx. mass: 8 kg (17.6 lb)

9.2.9 SGDB-60AN to 75AN-P SERVOPACKS

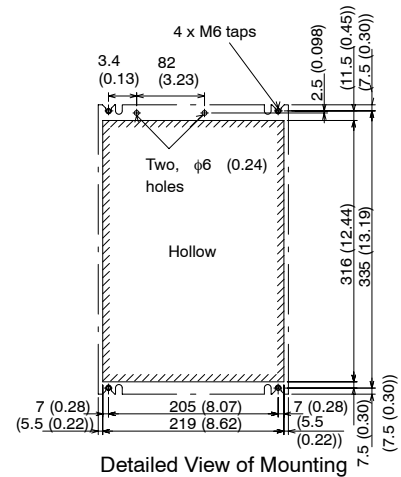
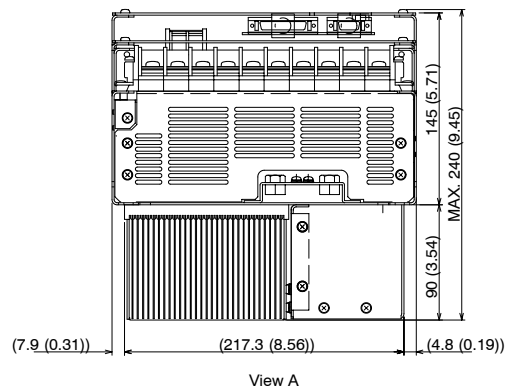
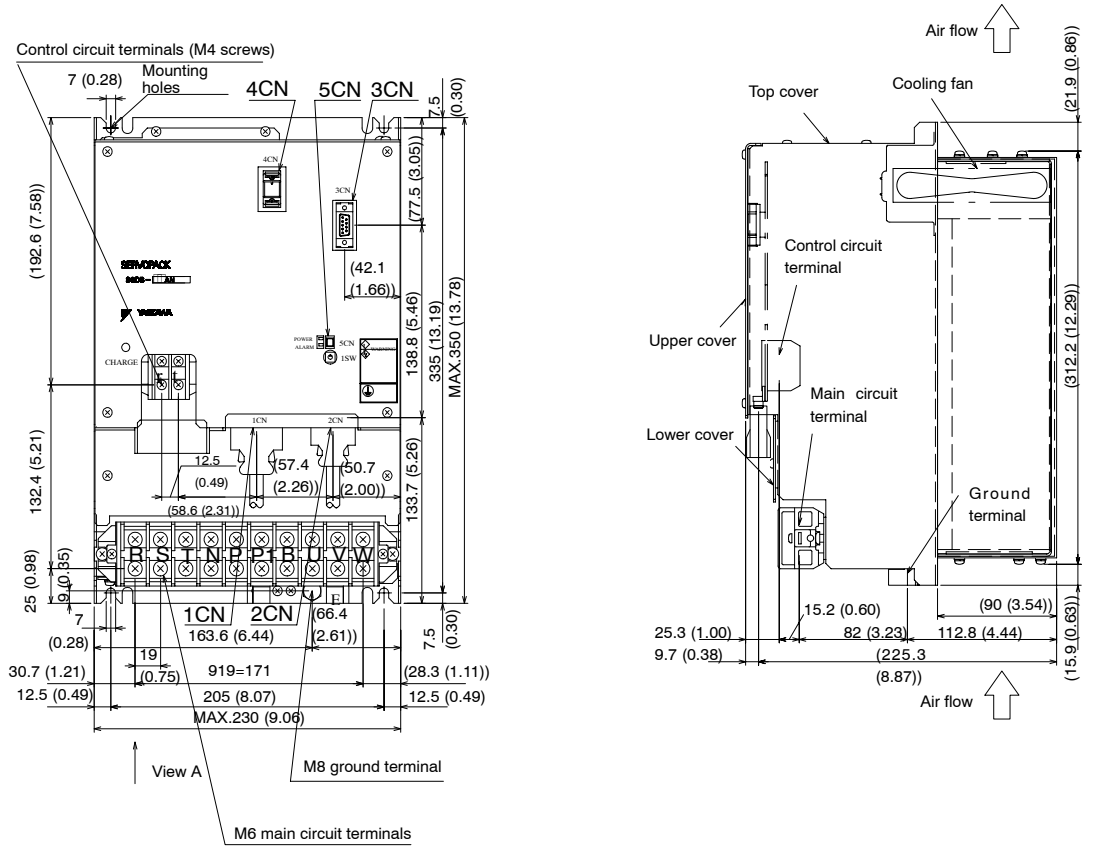

Approx. mass: 15.5 kg (34.2 lb)

9.2.10 SGDB-1AAN-P, 1EAN-P SERVOPACKS

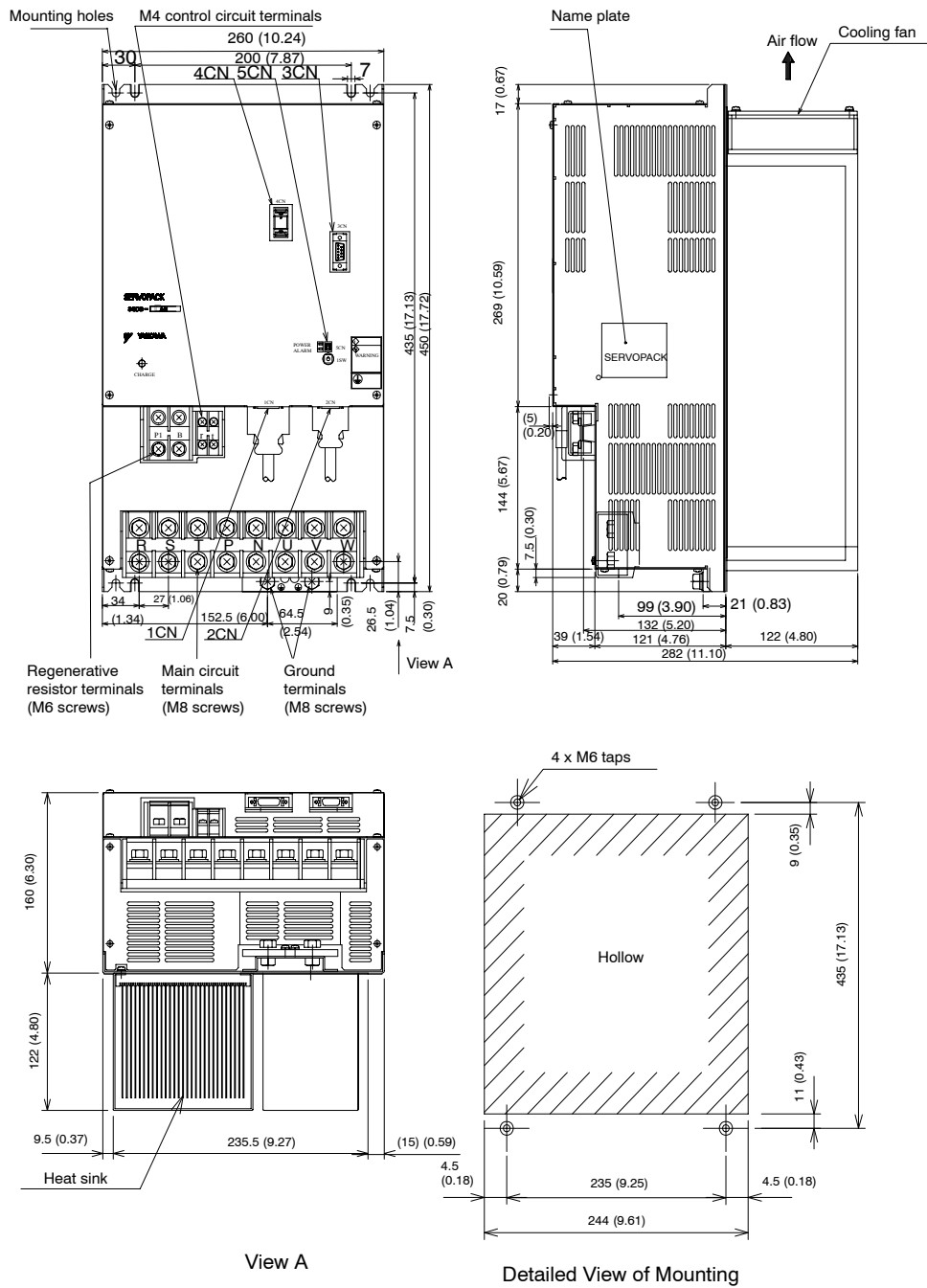

Approx. mass: 22 kg (48.5 lb)

■ Common for SGDB-05 to 1EAN□-P SERVOPACKS

Code	SERVOPACK End Connector	Comments
1CN	10226-52A2JL	Manufactured by Sumitomo 3M Co., Ltd.
2CN	10220-52A2JL	
4CN	MR-8RMD2(G)	Manufactured by Honda Tsushin Kogyo Co., Ltd.
5CN	DF11-4DP-2DSA	Manufactured by Hirose Electric Co., Ltd.

9.3 Cables

9.3.1 Encoder Cables

The following shows the dimensions and external appearance of encoder cables. Be sure to specify the type of cable when ordering.

■ For SGMG, SGMS and SGMD Servomotors

Incremental Encoder Cables (with Straight Plug)

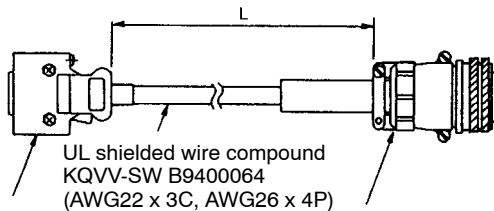

Shell: 10320-52A0-008
(manufactured by SUMITOMO 3M, Ltd.)
Plug: 10120-3000VE

MS3106B20-29S (Manufactured by
Daiichi Denshi Kogyo Co., Ltd.)
MS3057-12A cable clamp

Model	L mm (in)
DE9407234-1	$3000 \begin{matrix} +100 \\ 0 \end{matrix}$ $\left(\begin{matrix} +3.94 \\ 118.1 \\ 0 \end{matrix} \right)$
DE9407234-2	$5000 \begin{matrix} +100 \\ 0 \end{matrix}$ $\left(\begin{matrix} +3.94 \\ 196.85 \\ 0 \end{matrix} \right)$
DE9407234-3	$10000 \begin{matrix} +500 \\ 0 \end{matrix}$ $\left(\begin{matrix} +19.69 \\ 393.70 \\ 0 \end{matrix} \right)$
DE9407234-4	$15000 \begin{matrix} +500 \\ 0 \end{matrix}$ $\left(\begin{matrix} +19.69 \\ 590.55 \\ 0 \end{matrix} \right)$
DE9407234-5	$20000 \begin{matrix} +500 \\ 0 \end{matrix}$ $\left(\begin{matrix} +19.69 \\ 787.40 \\ 0 \end{matrix} \right)$

Incremental Encoder Cables (with L-shaped Plug)

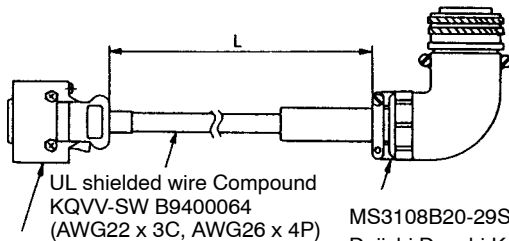

Shell: 10320-52A0-008
(manufactured by SUMITOMO 3M, Ltd.)
Plug: 10120-3000VE

MS3108B20-29S (Manufactured by
Daiichi Denshi Kogyo Co., Ltd.)
MS3057-12A cable clamp

Model	L mm (in)
DE9407235-1	$3000 \begin{matrix} +100 \\ 0 \end{matrix}$ $\left(\begin{matrix} +3.94 \\ 118.1 \\ 0 \end{matrix} \right)$
DE9407235-2	$5000 \begin{matrix} +100 \\ 0 \end{matrix}$ $\left(\begin{matrix} +3.94 \\ 196.85 \\ 0 \end{matrix} \right)$
DE9407235-3	$10000 \begin{matrix} +500 \\ 0 \end{matrix}$ $\left(\begin{matrix} +19.69 \\ 393.70 \\ 0 \end{matrix} \right)$
DE9407235-4	$15000 \begin{matrix} +500 \\ 0 \end{matrix}$ $\left(\begin{matrix} +19.69 \\ 590.55 \\ 0 \end{matrix} \right)$
DE9407235-5	$20000 \begin{matrix} +500 \\ 0 \end{matrix}$ $\left(\begin{matrix} +19.69 \\ 787.40 \\ 0 \end{matrix} \right)$

Incremental Encoder Cables (Encoder-end Split Leads)

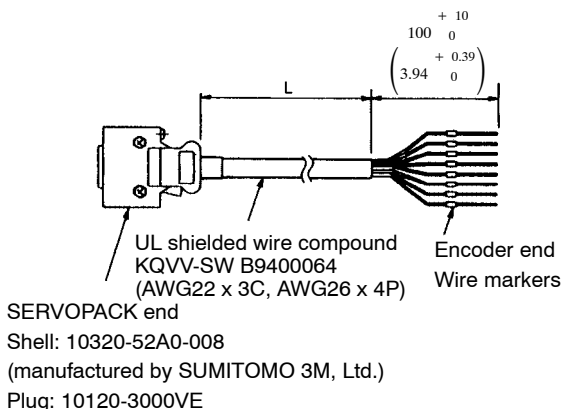

Model	L mm (in)
DE9406971-1	$3000 \begin{matrix} +100 \\ 0 \end{matrix} \begin{pmatrix} +3.94 \\ 0 \end{pmatrix}$
DE9406971-2	$5000 \begin{matrix} +100 \\ 0 \end{matrix} \begin{pmatrix} +3.94 \\ 0 \end{pmatrix}$
DE9406971-3	$10000 \begin{matrix} +100 \\ 0 \end{matrix} \begin{pmatrix} +19.69 \\ 393.70 \end{pmatrix}$
DE9406971-4	$15000 \begin{matrix} +100 \\ 0 \end{matrix} \begin{pmatrix} +19.69 \\ 590.55 \end{pmatrix}$
DE9406971-5	$20000 \begin{matrix} +100 \\ 0 \end{matrix} \begin{pmatrix} +19.69 \\ 787.40 \end{pmatrix}$

Connector: MS3106B20-29S
Straight plug: MS3106B20-29S
Cable clamp: MS3057-12A

* Case: 10320-52A0-008 (manufactured by SUMITOMO 3M, Ltd.)
Connector: 10120-3000VE (manufactured by SUMITOMO 3M, Ltd.)

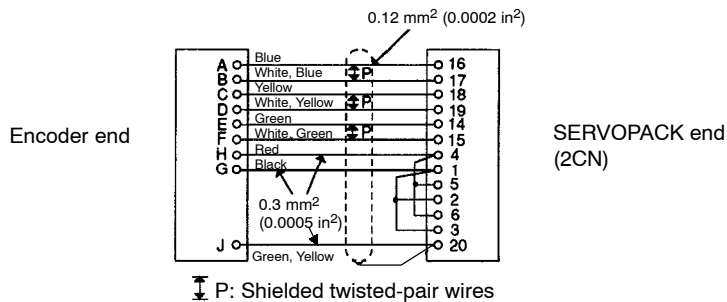

* Purchase plugs and cable clamps separately when ordering cable only.
See 9.4 "Connectors" for more details.

Absolute Encoder Cables (with Straight Plug)

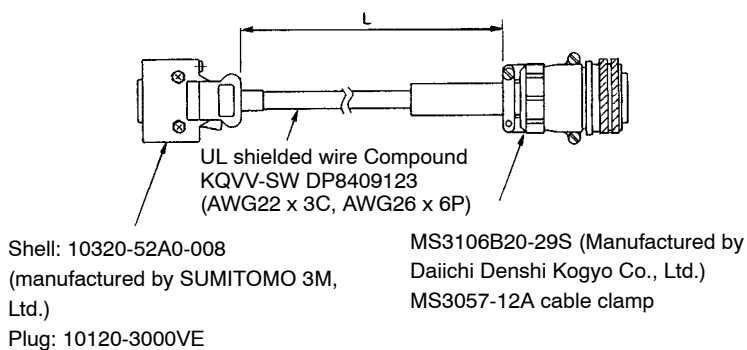

Model	L mm (in)
DE9407236-1	$3000 \begin{matrix} +100 \\ 0 \end{matrix} \begin{pmatrix} +3.94 \\ 0 \end{pmatrix}$
DE9407236-2	$5000 \begin{matrix} +100 \\ 0 \end{matrix} \begin{pmatrix} +3.94 \\ 0 \end{pmatrix}$
DE9407236-3	$10000 \begin{matrix} +500 \\ 0 \end{matrix} \begin{pmatrix} +19.69 \\ 393.70 \end{pmatrix}$
DE9407236-4	$15000 \begin{matrix} +500 \\ 0 \end{matrix} \begin{pmatrix} +19.69 \\ 590.55 \end{pmatrix}$
DE9407236-5	$20000 \begin{matrix} +500 \\ 0 \end{matrix} \begin{pmatrix} +19.69 \\ 787.40 \end{pmatrix}$

Absolute Encoder Cables (with L-shaped Plug)

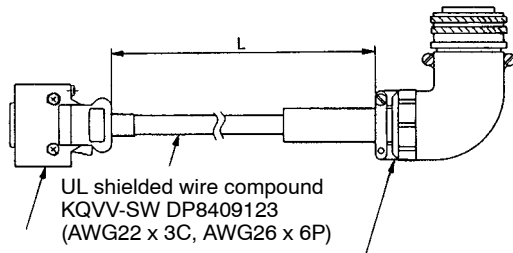

Shell: 10320-52A0-008
 (manufactured by SUMITOMO 3M, Ltd.)
 Plug: 10120-3000VE

MS3108B20-29S (Manufactured by Daiichi Denshi Kogyo Co., Ltd.)
 MS3057-12A cable clamp

Model	L mm (in)
DE9407237-1	$3000 \begin{matrix} +100 \\ 0 \end{matrix} \begin{pmatrix} 118.1 & +3.94 \\ 0 & 0 \end{pmatrix}$
DE9407237-2	$5000 \begin{matrix} +100 \\ 0 \end{matrix} \begin{pmatrix} 196.85 & +3.94 \\ 0 & 0 \end{pmatrix}$
DE9407237-3	$10000 \begin{matrix} +500 \\ 0 \end{matrix} \begin{pmatrix} 393.70 & +19.69 \\ 0 & 0 \end{pmatrix}$
DE9407237-4	$15000 \begin{matrix} +500 \\ 0 \end{matrix} \begin{pmatrix} 590.55 & +19.69 \\ 0 & 0 \end{pmatrix}$
DE9407237-5	$20000 \begin{matrix} +500 \\ 0 \end{matrix} \begin{pmatrix} 787.40 & +19.69 \\ 0 & 0 \end{pmatrix}$

Absolute Encoder Cables (Encoder-end Split Leads)

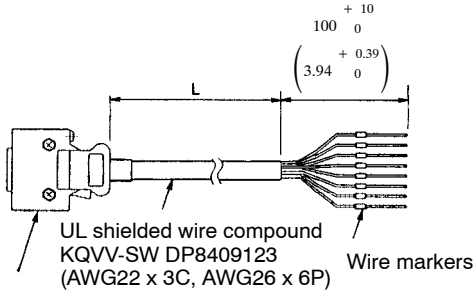

SERVOPACK end
 Shell: 10320-52A0-008
 (manufactured by SUMITOMO 3M, Ltd.)
 Plug: 10120-3000VE

Model	L mm (in)
DE9406972-1	$3000 \begin{matrix} +100 \\ 0 \end{matrix} \begin{pmatrix} 118.1 & +3.94 \\ 0 & 0 \end{pmatrix}$
DE9406972-2	$5000 \begin{matrix} +100 \\ 0 \end{matrix} \begin{pmatrix} 196.85 & +3.94 \\ 0 & 0 \end{pmatrix}$
DE9406972-3	$10000 \begin{matrix} +500 \\ 0 \end{matrix} \begin{pmatrix} 393.70 & +19.69 \\ 0 & 0 \end{pmatrix}$
DE9406972-4	$15000 \begin{matrix} +500 \\ 0 \end{matrix} \begin{pmatrix} 590.55 & +19.69 \\ 0 & 0 \end{pmatrix}$
DE9406972-5	$20000 \begin{matrix} +500 \\ 0 \end{matrix} \begin{pmatrix} 787.40 & +19.69 \\ 0 & 0 \end{pmatrix}$

Connector: Straight plug: MS3106B20-29S
 Cable clamp: MS3057-12A

* Case: 10320-52A0-008 (manufactured by SUMITOMO 3M, Ltd.)
 Connector: 10120-3000VE (manufactured by SUMITOMO 3M, Ltd.)

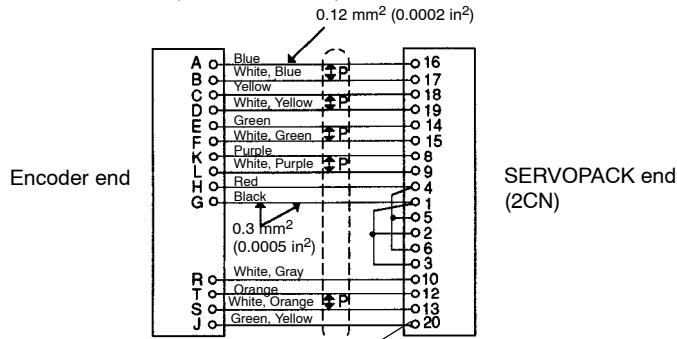

⚡ P: Shielded twisted-pair wires

* Purchase plugs and cable clamps separately when ordering cable only.
 See 9.4 Connectors for more details.

Incremental Encoder Cables (Cable Only)

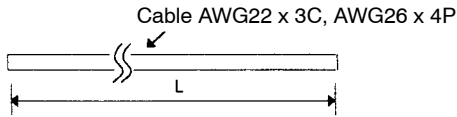

Model	L mm (in)
B9400064-1	$3000 \begin{matrix} +100 \\ 0 \end{matrix} \begin{pmatrix} 118.1 & +3.94 \\ 0 & 0 \end{pmatrix}$
B9400064-2	$5000 \begin{matrix} +100 \\ 0 \end{matrix} \begin{pmatrix} 196.85 & +3.94 \\ 0 & 0 \end{pmatrix}$
B9400064-3	$10000 \begin{matrix} +100 \\ 0 \end{matrix} \begin{pmatrix} 393.70 & +19.69 \\ 0 & 0 \end{pmatrix}$
B9400064-4	$15000 \begin{matrix} +100 \\ 0 \end{matrix} \begin{pmatrix} 590.55 & +19.69 \\ 0 & 0 \end{pmatrix}$
B9400064-5	$20000 \begin{matrix} +100 \\ 0 \end{matrix} \begin{pmatrix} 787.40 & +19.69 \\ 0 & 0 \end{pmatrix}$

Connector
Straight plug: MS3106B20-29S
Cable clamp: MS3057-12A

Case: 10320-52A0-008 (manufactured by SUMITOMO 3M, Ltd.)
Connector: 10120-3000VE (manufactured by SUMITOMO 3M, Ltd.)

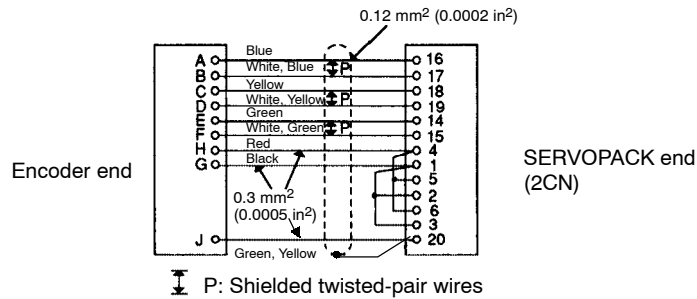

* Purchase plugs, cable clamps, cases and connectors separately when ordering cable only. See 9.4 "Connectors" for more details.

Absolute Encoder Cables (Cable Only)

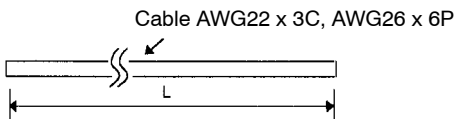

Model	L mm (in)
DP8409123-1	$3000 \begin{matrix} +100 \\ 0 \end{matrix} \begin{pmatrix} 118.1 & +3.94 \\ 0 & 0 \end{pmatrix}$
DP8409123-2	$5000 \begin{matrix} +100 \\ 0 \end{matrix} \begin{pmatrix} 196.85 & +3.94 \\ 0 & 0 \end{pmatrix}$
DP8409123-3	$10000 \begin{matrix} +500 \\ 0 \end{matrix} \begin{pmatrix} 393.70 & +19.69 \\ 0 & 0 \end{pmatrix}$
DP8409123-4	$15000 \begin{matrix} +500 \\ 0 \end{matrix} \begin{pmatrix} 590.55 & +19.69 \\ 0 & 0 \end{pmatrix}$
DP8409123-5	$20000 \begin{matrix} +500 \\ 0 \end{matrix} \begin{pmatrix} 787.40 & +19.69 \\ 0 & 0 \end{pmatrix}$

9.3.1 Encoder Cables

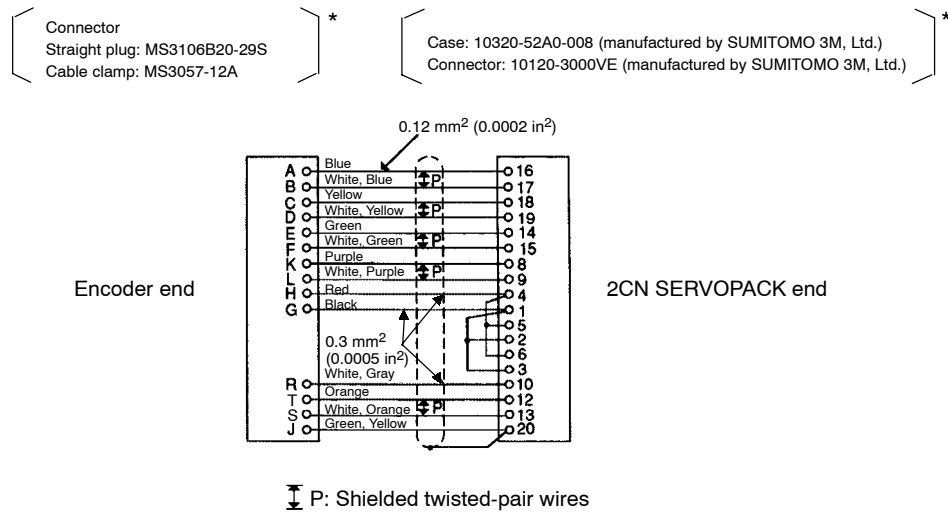

* Purchase plugs, cable clamps, cases and connectors separately when ordering cable only. See 9.4 “Connectors” for more details.

■ For SGM and SGMP Servomotors

Incremental Encoder Cables (with Connectors on Both Ends)

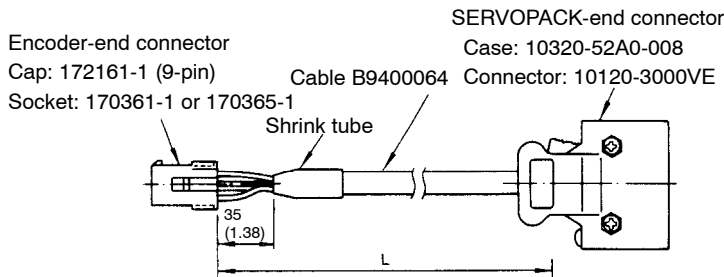

Model	L mm (in)
DP9320089-1	3000 ⁺¹⁰⁰ ₀ (118.1 ^{+3.94} ₀)
DP9320089-2	5000 ⁺¹⁰⁰ ₀ (196.85 ^{+3.94} ₀)
DP9320089-3	10000 ⁺⁵⁰⁰ ₀ (393.70 ^{+19.69} ₀)
DP9320089-4	15000 ⁺⁵⁰⁰ ₀ (590.55 ^{+19.69} ₀)
DP9320089-5	20000 ⁺⁵⁰⁰ ₀ (787.40 ^{+19.69} ₀)

Absolute Encoder Cables (with Connectors on Both Ends)

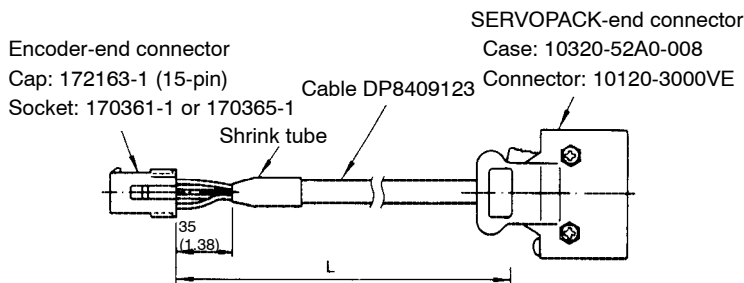

Model	L mm (in)
DP9320088-1	3000 ⁺¹⁰⁰ ₀ (118.1 ^{+3.94} ₀)
DP9320088-2	5000 ⁺¹⁰⁰ ₀ (196.85 ^{+3.94} ₀)
DP9320088-3	10000 ⁺⁵⁰⁰ ₀ (393.70 ^{+19.69} ₀)
DP9320088-4	15000 ⁺⁵⁰⁰ ₀ (590.55 ^{+19.69} ₀)
DP9320088-5	20000 ⁺⁵⁰⁰ ₀ (787.40 ^{+19.69} ₀)

Incremental Encoder Cables (with Servomotor-end Connector)

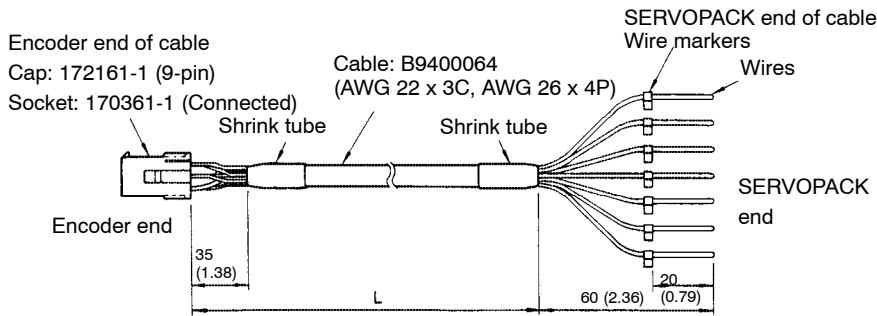

Model	L mm (in)
DP9320086-1	$3000 \begin{matrix} +100 \\ 0 \\ 118.1 \end{matrix} \begin{matrix} \\ 0 \\ 0 \end{matrix}$
DP9320086-2	$5000 \begin{matrix} +100 \\ 0 \\ 196.85 \end{matrix} \begin{matrix} \\ 0 \\ 0 \end{matrix}$
DP9320086-3	$10000 \begin{matrix} +100 \\ 0 \\ 393.70 \end{matrix} \begin{matrix} \\ 0 \\ 0 \end{matrix}$
DP9320086-4	$15000 \begin{matrix} +100 \\ 0 \\ 590.55 \end{matrix} \begin{matrix} \\ 0 \\ 0 \end{matrix}$
DP9320086-5	$20000 \begin{matrix} +100 \\ 0 \\ 787.40 \end{matrix} \begin{matrix} \\ 0 \\ 0 \end{matrix}$

*
 Case: 10320-52A0-008 (manufactured by SUMITOMO 3M, Ltd.)
 Connector: 10120-3000VE (manufactured by SUMITOMO 3M, Ltd.)

Cap: 172161-1
 Socket: 170361-1

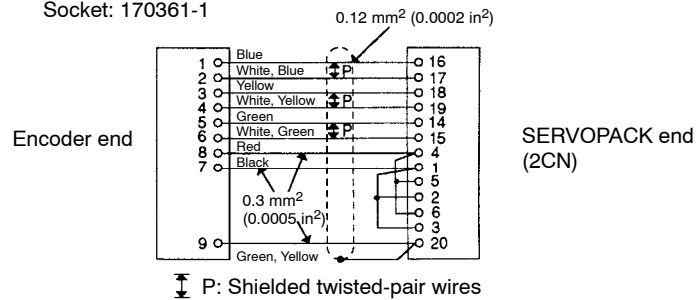

* Purchase plugs and cable clamps separately when ordering cable only.
 See 9.4 "Connectors" for more details.

Absolute Encoder Cables (with Servomotor-end Connector)

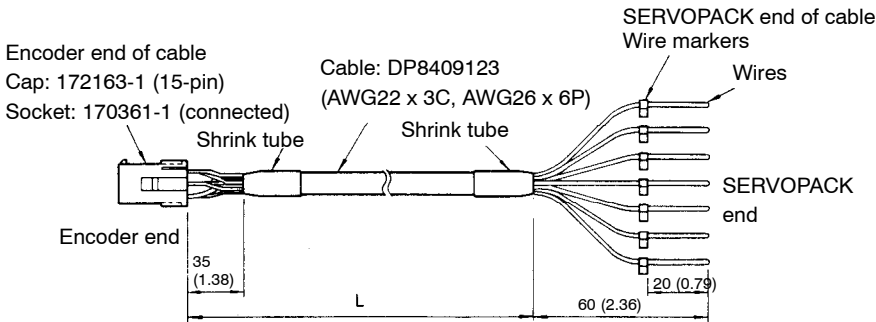

Model	L mm (in)
DP9320085-1	$3000 \begin{matrix} +100 \\ 0 \end{matrix} \begin{pmatrix} +3.94 \\ 0 \end{pmatrix}$ (118.1 0)
DP9320085-2	$5000 \begin{matrix} +100 \\ 0 \end{matrix} \begin{pmatrix} +3.94 \\ 0 \end{pmatrix}$ (196.85 0)
DP9320085-3	$10000 \begin{matrix} +500 \\ 0 \end{matrix} \begin{pmatrix} +19.69 \\ 0 \end{pmatrix}$ (393.70 0)
DP9320085-4	$15000 \begin{matrix} +500 \\ 0 \end{matrix} \begin{pmatrix} +19.69 \\ 0 \end{pmatrix}$ (590.55 0)
DP9320085-5	$20000 \begin{matrix} +500 \\ 0 \end{matrix} \begin{pmatrix} +19.69 \\ 0 \end{pmatrix}$ (787.40 0)

Case: 10320-52A0-008 (manufactured by SUMITOMO 3M, Ltd.)
 Connector: 10120-3000VE (manufactured by SUMITOMO 3M, Ltd.) *

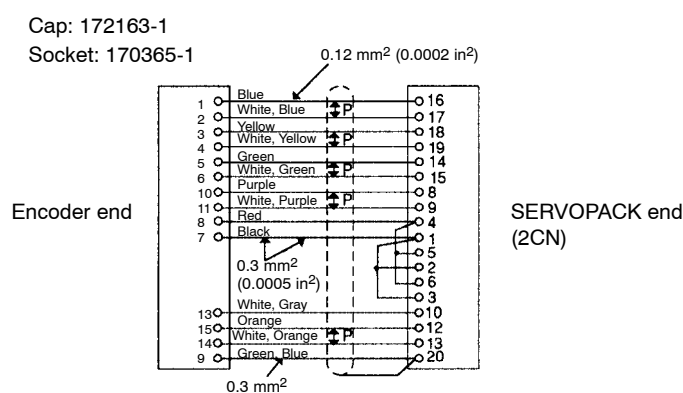

* Purchase plugs and cable clamps separately when ordering cable only.
 See 9.4 "Connectors" for more details.

Incremental Encoder Cables (Cable Only)

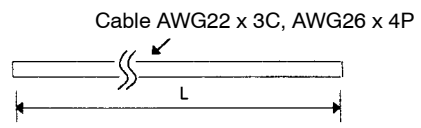

Model	L mm (in)
B9400064-1	$3000 \begin{matrix} +100 \\ 0 \end{matrix} \begin{pmatrix} +3.94 \\ 0 \end{pmatrix}$
B9400064-2	$5000 \begin{matrix} +100 \\ 0 \end{matrix} \begin{pmatrix} +3.94 \\ 0 \end{pmatrix}$
B9400064-3	$10000 \begin{matrix} +100 \\ 0 \end{matrix} \begin{pmatrix} +19.69 \\ 0 \end{pmatrix}$
B9400064-4	$15000 \begin{matrix} +100 \\ 0 \end{matrix} \begin{pmatrix} +19.69 \\ 0 \end{pmatrix}$
B9400064-5	$20000 \begin{matrix} +100 \\ 0 \end{matrix} \begin{pmatrix} +19.69 \\ 0 \end{pmatrix}$

Cap: 172161-1 (Manufactured by Japan AMP Co., Ltd.) Socket: 170361-1 or 170365-1 (Manufactured by Japan AMP Co., Ltd.)	*	Case: 10320-52A0-008 (Manufactured by SUMITOMO 3M, Ltd.) Connector: 10120-3000VE (Manufactured by SUMITOMO 3M, Ltd.)
---	---	---

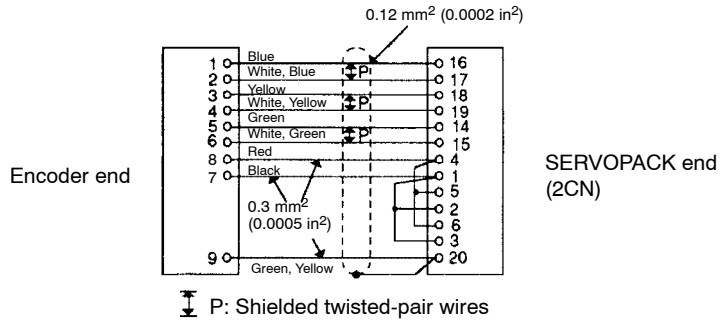

* Purchase plugs, cable clamps, cases and connectors separately when ordering cable only. See 9.4 "Connectors" for more details.

Absolute Encoder Cables (Cable Only)

Cable AWG22 x 3C, AWG26 x 6P

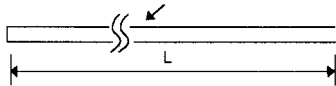

Model	L mm (in)
DP8409123-1	$3000 \begin{matrix} +100 \\ 0 \end{matrix} \left(\begin{matrix} +3.94 \\ 118.1 \end{matrix} \right)$
DP8409123-2	$5000 \begin{matrix} +100 \\ 0 \end{matrix} \left(\begin{matrix} +3.94 \\ 196.85 \end{matrix} \right)$
DP8409123-3	$10000 \begin{matrix} +500 \\ 0 \end{matrix} \left(\begin{matrix} +19.69 \\ 393.70 \end{matrix} \right)$
DP8409123-4	$15000 \begin{matrix} +500 \\ 0 \end{matrix} \left(\begin{matrix} +19.69 \\ 590.55 \end{matrix} \right)$
DP8409123-5	$20000 \begin{matrix} +500 \\ 0 \end{matrix} \left(\begin{matrix} +19.69 \\ 787.40 \end{matrix} \right)$

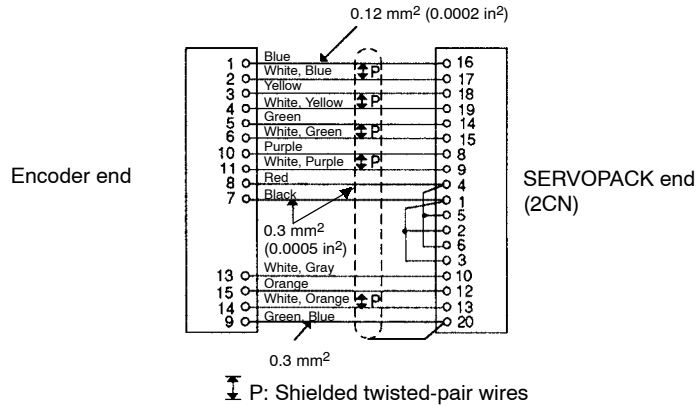
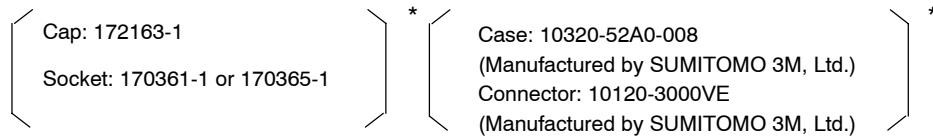

* Purchase plugs, cable clamps, cases and connectors separately when ordering cable only. See 9.4 “Connectors” for more details.

Encoder cable details are summarized in the following table. These cables are not SERVOPACK or Servomotor accessories and must be purchased separately in standard specified lengths as required.

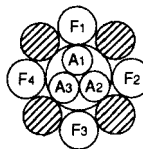
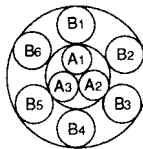
Cable Specification	Incremental Encoder (Yaskawa Drawing #B9400064)	Absolute Encoder (Yaskawa Drawing #DP8409123)
Basic Specifications	Compound KQVV-SW AWG22 × 3 Cores, AWG26 × 4P	Compound KQVV-SW AWG22 × 3 Cores, AWG26 × 6P
Finished Dimension	φ7.5 mm (φ0.30 in)	φ8.0 mm (φ0.31 in)
Internal Structure and Lead Colors	 <p>A₁ Red A₂ Black A₃ Green/Yellow F₁ Blue-White/Blue Twisted-pair wires F₂ Yellow-White/Yellow Twisted-pair wires F₃ Green-White/Green Twisted-pair wires F₄ Orange-White/Orange Twisted-pair wires</p>	 <p>A₁ Red A₂ Black A₃ Green/Yellow B₁ Blue-White/Blue Twisted-pair wires B₂ Yellow-White/Yellow Twisted-pair wires B₃ Green-White/Green Twisted-pair wires B₄ Orange-White/Orange Twisted-pair wires B₅ Purple-White/Purple Twisted-pair wires B₆ Gray-White/Gray Twisted-pair wires</p>
Yaskawa Standard Specifications	Standard lengths: 3 m (9.84 ft), 5 m (16.40 ft), 10 m (32.81 ft), 15 m (49.21 ft), 20 m (65.62 ft) (See note 1.)	

- Note 1.** The allowable wiring distance between the SERVOPACK and Servomotor (PG) is 20 m (65.62 ft) maximum when the appropriate cable is used.
- 2.** See Encoder Cables in this Chapter for more details on cables with connectors.

9.3.2 Servomotor Cables

See 8.3.1 *Rated Current and cable Specifications* for more details on Servomotor cables. Users must select and purchase the cables separately according to their specifications.

Users using the SGMP Servomotor (1.5 kW) must purchase the cables below.

■ Cables for Servomotors without Brakes (with Connector and AMP Terminal)

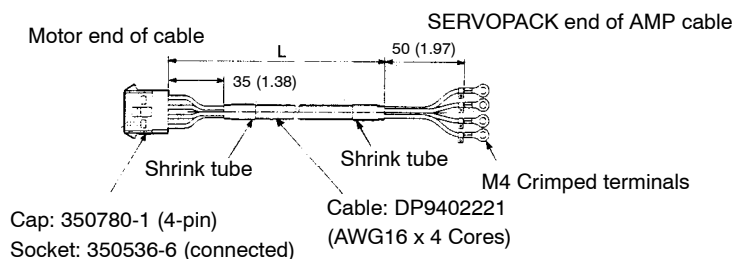

Model	L mm (in)
DP9320827-1	$3000 \begin{matrix} +100 \\ 0 \end{matrix} \begin{pmatrix} +3.94 \\ 118.1 \\ 0 \end{pmatrix}$
DP9320827-2	$5000 \begin{matrix} +100 \\ 0 \end{matrix} \begin{pmatrix} +3.94 \\ 196.85 \\ 0 \end{pmatrix}$
DP9320827-3	$10000 \begin{matrix} +500 \\ 0 \end{matrix} \begin{pmatrix} +19.69 \\ 393.70 \\ 0 \end{pmatrix}$
DP9320827-4	$15000 \begin{matrix} +500 \\ 0 \end{matrix} \begin{pmatrix} +19.69 \\ 590.55 \\ 0 \end{pmatrix}$
DP9320827-5	$20000 \begin{matrix} +500 \\ 0 \end{matrix} \begin{pmatrix} +19.69 \\ 787.40 \\ 0 \end{pmatrix}$

■ Cables for Servomotors with Brakes (with Connector and AMP Terminal)

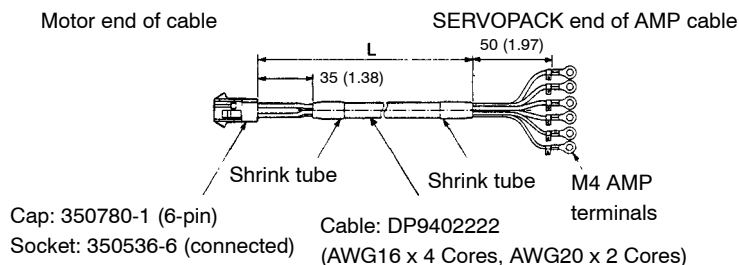

Model	L mm (in)
DP9320828-1	$3000 \begin{matrix} +100 \\ 0 \end{matrix} \begin{pmatrix} +3.94 \\ 118.1 \\ 0 \end{pmatrix}$
DP9320828-2	$5000 \begin{matrix} +100 \\ 0 \end{matrix} \begin{pmatrix} +3.94 \\ 196.85 \\ 0 \end{pmatrix}$
DP9320828-3	$10000 \begin{matrix} +500 \\ 0 \end{matrix} \begin{pmatrix} +19.69 \\ 393.70 \\ 0 \end{pmatrix}$
DP9320828-4	$15000 \begin{matrix} +500 \\ 0 \end{matrix} \begin{pmatrix} +19.69 \\ 590.55 \\ 0 \end{pmatrix}$
DP9320828-5	$20000 \begin{matrix} +500 \\ 0 \end{matrix} \begin{pmatrix} +19.69 \\ 787.40 \\ 0 \end{pmatrix}$

9.3.3 I/O Signal Cables (1CN)

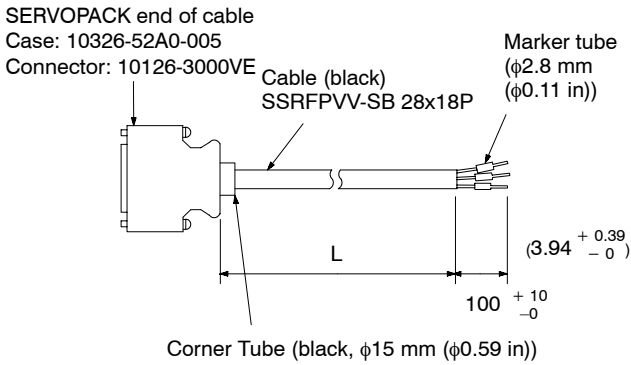

Model	L mm (in)
DE9411355-1	1000 $\begin{matrix} +30 \\ 0 \end{matrix}$ $\left(\begin{matrix} +1.18 \\ 39.37 \\ 0 \end{matrix} \right)$
DE9411355-2	2000 $\begin{matrix} +50 \\ 0 \end{matrix}$ $\left(\begin{matrix} +1.97 \\ 78.74 \\ 0 \end{matrix} \right)$
DE9411355-3	3000 $\begin{matrix} +50 \\ 0 \end{matrix}$ $\left(\begin{matrix} +1.97 \\ 118.1 \\ 0 \end{matrix} \right)$

9.3.4 MECHATROLINK Communication Cables (4CN)

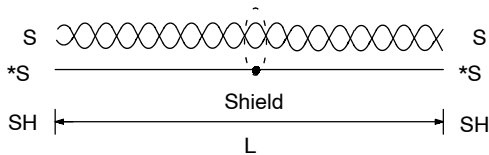

Model	Cable Length m (feet)
DE9411358-1	10 $\begin{matrix} +1 \\ 0 \end{matrix}$ $\left(\begin{matrix} +3.28 \\ 32.81 \\ 0 \end{matrix} \right)$
DE9411358-2	20 $\begin{matrix} +1 \\ 0 \end{matrix}$ $\left(\begin{matrix} +3.28 \\ 65.62 \\ 0 \end{matrix} \right)$
DE9411358-3	30 $\begin{matrix} +1 \\ 0 \end{matrix}$ $\left(\begin{matrix} +3.28 \\ 98.43 \\ 0 \end{matrix} \right)$
DE9411358-4	50 $\begin{matrix} +1 \\ 0 \end{matrix}$ $\left(\begin{matrix} +3.28 \\ 164.04 \\ 0 \end{matrix} \right)$
DE9411358-5	100 $\begin{matrix} +1 \\ 0 \end{matrix}$ $\left(\begin{matrix} +3.28 \\ 328.08 \\ 0 \end{matrix} \right)$
DE9411358-6	200 $\begin{matrix} +1 \\ 0 \end{matrix}$ $\left(\begin{matrix} +3.28 \\ 656.17 \\ 0 \end{matrix} \right)$
DE9411358-7	300 $\begin{matrix} +1 \\ 0 \end{matrix}$ $\left(\begin{matrix} +3.28 \\ 984.25 \\ 0 \end{matrix} \right)$
DE9411358-8	500 $\begin{matrix} +1 \\ 0 \end{matrix}$ $\left(\begin{matrix} +3.28 \\ 1640.42 \\ 0 \end{matrix} \right)$
DE9411358-9	1000 $\begin{matrix} +1 \\ 0 \end{matrix}$ $\left(\begin{matrix} +3.28 \\ 3280.84 \\ 19.69 \\ 0 \end{matrix} \right)$

9.4 Connectors

9.4.1 SGMG, SGMS and SGMD Servomotors Connections

Connectors are divided into the three types shown in the figure: encoder connector for the Servomotor and SERVOPACK ends of the cable and a Servomotor connector for the Servomotor end of the cable. The type of encoder (incremental, absolute) does not matter with connectors.

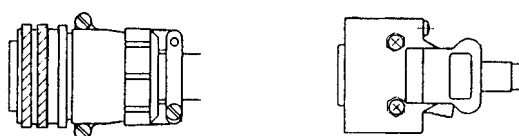

The type of connector varies according to the following:

- Straight plug or L-shaped plug
- Servomotor with or without brake
- Standard specification or IP67 specification

Connectors also vary according to Servomotor type and capacity. Therefore take this into account when ordering a connector. A connector kit is required in the following cases:

- All Servomotor cables (whether or not the Servomotor has a brake).
- An encoder cable with a SERVOPACK end connector (loose leads on the encoder end) or an encoder cable only regardless of whether the encoder is incremental or absolute.
- All IP67-compatible encoder cables (Servomotor and SERVOPACK ends).

■ Encoder Cable Connectors

Encoder connectors are classified into four types according to the following:

- Standard specification or IP67 specification
- Straight or L-shaped plug

Environmental Conditions		Parts	Straight	L-shaped (Angled)	Manufacturer
Standard Environment	-	Plug	MS3106B20-29S	MS3108B20-29S	Daiichi Denshi Kogyo Co., Ltd.
		Cable clamp	MS3057-12A-*		
IP67-compatible Environment	With a flexible conduit	Plug	MS3106A20-29S (D190)	-	
	Without a flexible conduit	Plug	MS3106A20-29S(D190)		
		Back shell	CE02-20BS-S	CE-20BA-S	
		Cable clamp	CE3057-12A-*		

Connector Combination

The following illustration shows combination of connectors manufactured by Daiichi Denshi Kogyo Co., Ltd.

- **Standard Environment Connector Combination**

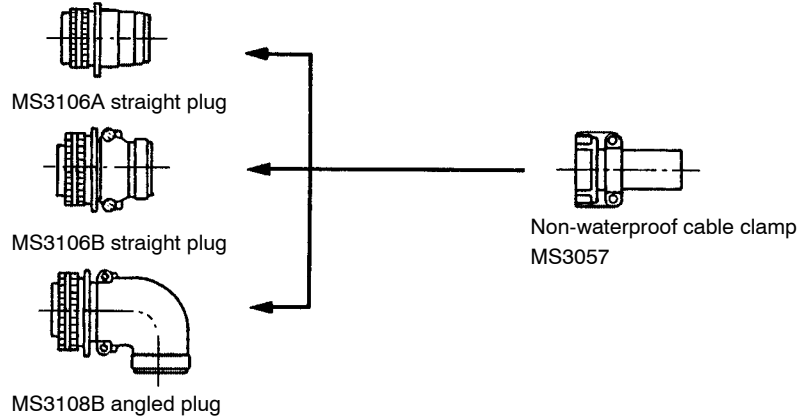

- **IP67-compatible Environment Connector Combination**

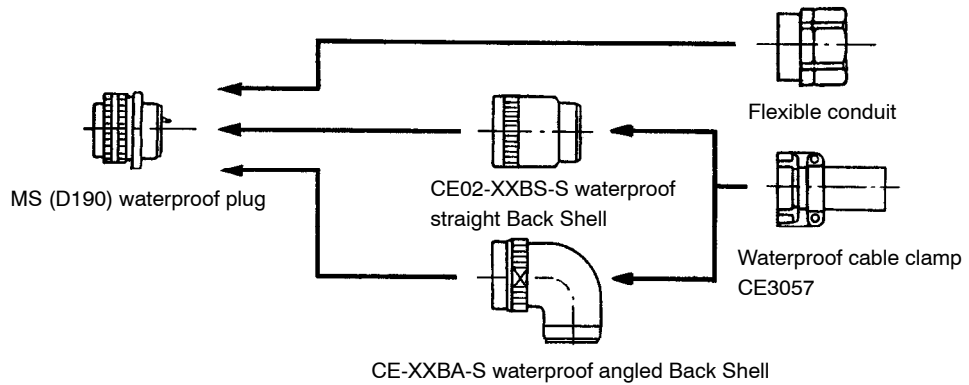

■ Servomotor Cable Connectors

One of the following Servomotor cable connectors is used depending on the Servomotor type and capacity, whether there is a brake or not, and whether the specification is IP67 or not. The user must provide a crimped terminal for the SERVOPACK end.

- **Connectors in Standard Environment**

The following table shows connectors for standard Servomotors (without brake).

Servomotor Model	Servomotor End Connector			
	Receptacle	L-shaped Plug	Straight Plug	Cable Clamp
SGMS- 10A□A 15A□A 20A□A	MS3102A18-10P	MS3108B18-10S	MS3106B18-10S	MS3057-10A
	MS3102A22-22P	MS3108B22-22S	MS3106B22-22S	MS3057-12A
SGMG- 05A□A 09A□A 13A□A	MS3102A18-10P	MS3108B18-10S	MS3106B18-10S	MS3057-10A
	MS3102A22-22P	MS3108B22-22S	MS3106B22-22S	MS3057-12A
	MS3102A32-17P	MS3108B32-17S	MS3106B32-17S	MS3057-20A
SGMG- 03A□B 06A□B 09A□B	MS3102A18-10P	MS3108B18-10S	MS3106B18-10S	MS3057-10A
	MS3102A22-22P	MS3108B22-22S	MS3106B22-22S	MS3057-12A
	MS3102A32-17P	MS3108B32-17S	MS3106B32-17S	MS3057-20A
SGMG- 12A□B 20A□B 30A□B	MS3102A18-10P	MS3108B18-10S	MS3106B18-10S	MS3057-10A
	MS3102A22-22P	MS3108B22-22S	MS3106B22-22S	MS3057-12A
	MS3102A32-17P	MS3108B32-17S	MS3106B32-17S	MS3057-20A
SGMG- 44A□B 60A□B	MS3102A18-10P	MS3108B18-10S	MS3106B18-10S	MS3057-10A
	MS3102A22-22P	MS3108B22-22S	MS3106B22-22S	MS3057-12A
	MS3102A32-17P	MS3108B32-17S	MS3106B32-17S	MS3057-20A
SGMD- 22A□A 32A□A 40A□A	MS3102A24-10P	MS3108B24-10S	MS3106B24-10S	MS3057-16A

Connector on motor
end already provided

Provided by the user.

MS3106B Straight Plug Shell

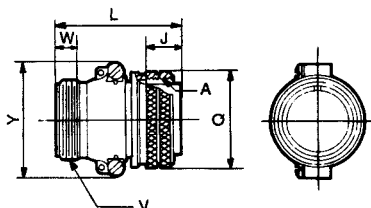

Servodrives Dimensional Drawings

9.4.1 SGMG, SGMS and SGM D Servomotors Connections

[mm (in)]

Shell Size	Joint Screw A	Length of Joint Portion J±0.12 (0.0047)	Overall Length L max.	Outside Diameter of Joint Nut $\phi Q \begin{smallmatrix} +0 \\ -0.38 \end{smallmatrix} (0.015)$	Cable Clamp Mounting Screw V	Effective Screw Length W min.	Maximum Width Y max.
18	1 1/8-18UNEF	18.26 (0.718)	52.37 (2.062)	34.13 (1.344)	1-20UNEF	9.53 (0.375)	42 (1.65)
22	1 3/8-18UNEF	18.26 (0.718)	55.57 (2.188)	40.48 (1.594)	1 3/16-18UNEF	9.53 (0.375)	50 (1.97)
24	1 1/2-18UNEF	18.26 (0.718)	58.72 (2.312)	43.63 (1.718)	1 7/16-18UNEF	9.53 (0.375)	53 (2.09)
32	2-18UNS	18.26 (0.718)	61.92 (2.438)	56.33 (2.222)	1 3/4-18UNS	11.13 (0.4382)	66 (2.60)

MS3108B L-shaped Plug Shell

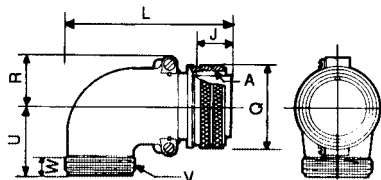

[mm (in)]

Shell Size	Joint Screw A	Length of Joint Portion J±0.12 (0.0047)	Overall Length L max.	Outside Diameter of Joint Nut $\phi Q \begin{smallmatrix} +0 \\ -0.38 \end{smallmatrix} (0.015)$	R±0.5 (0.020)	U±0.5 (0.020)	Cable Clamp Mounting Screw V	Effective Screw Length W max.
10SL								
18	1 1/8-18 UNEF	18.26 (0.7189)	68.27 (2.688)	34.13 (1.344)	20.5 (0.807)	30.2 (1.19)	1-20UNEF	9.53 (0.375)
22	1 3/8-18 UNEF	18.26 (0.7189)	76.98 (3.031)	40.48 (1.594)	24.1 (0.949)	33.3 (1.31)	1 3/16-18UNEF	9.53 (0.375)
24	1 1/2-18 UNEF	18.26 (0.7189)	86.51 (3.406)	43.63 (1.718)	25.6 (1.01)	36.5 (1.44)	1 7/16-18UNEF	9.53 (0.375)
32	2-18UNS	18.26 (0.7189)	95.25 (3.750)	56.33 (2.222)	32.8 (1.29)	44.4 (1.75)	1 3/4-18UNS	11.13 (0.438)

MS3106A Straight Plug Solid Shell

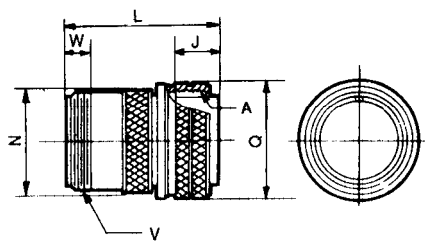

[mm (in)]

Shell Size	Joint Screw A	Length of Joint Portion $J \pm 0.12$ (0.0047)	Overall Length L max.	Outside Diameter of Joint Nut $\phi Q \begin{smallmatrix} +0 \\ -0.38 \end{smallmatrix}$ (0.015)	Outer Diameter $\phi N \pm 0.5$ (0.020)	Cable Clamp Mounting Screw V	Effective Screw Length W max.
10SL	5/8-24UNEF	13.49 (0.5311)	34.9 (1.37)	22.22 (0.8748)	19.12 (0.7528)	5/8-24UNEF	9.53 (0.375)

MS3057-XXA Cable Clamp with Rubber Bushing

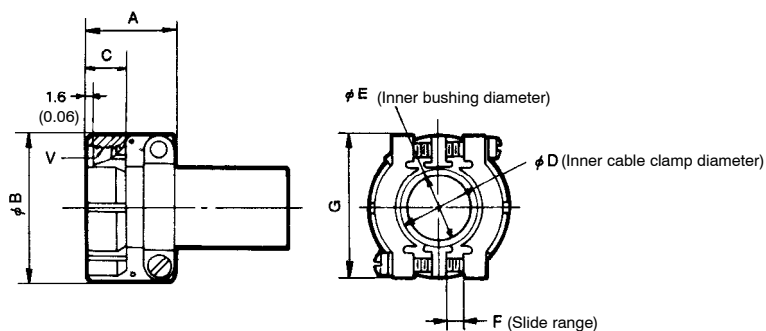

[mm (in)]

Part Number	Applicable Connector Shell Size	Overall Length $A \pm 0.7$ (0.028)	Outer Diameter $\phi B \pm 0.7$ (0.028)	Effective Screw Length C	ϕD	ϕE	F	$G \pm 0.7$ (0.028)	Mounting Screw V	Attached Bushing
MS3057-10A	18	23.8 (0.937)	30.1 (1.19)	10.3 (0.406)	15.9 (0.626)	14.3 (0.563)	3.2 (0.13)	31.7 (1.25)	1-20UNEF	AN3420-10
MS3057-12A	20, 22	23.8 (0.937)	35.0 (1.38)	10.3 (0.406)	19.0 (0.748)	15.9 (0.626)	4.0 (0.16)	37.3 (1.47)	1 3/16-18UNEF	AN3420-12
MS3057-16A	24, 28	26.2 (1.03)	42.1 (1.66)	10.3 (0.406)	23.8 (0.937)	15.9 (0.626)	4.8 (0.19)	42.9 (1.69)	1 7/16-18UNEF	AN3420-12 AN3420-16
MS3057-20A	32	27.8 (1.09)	51.6 (2.03)	11.9 (0.469)	31.7 (1.25)	19.1 (0.752) 23.8 (0.937)	6.3 (0.25)	51.6 (2.03)	1 3/4-18UNS	AN3420-16 AN3420-20

The following table shows connectors for Servomotors with brake.

Servomotor Model	Servomotor End Connector			
	Receptacle	L-shaped Plug	Straight Plug	Cable Clamp
SGMS- 10A□A 15A□A 20A□A	MS3102A20-15P	MS3108B20-15S	MS3106B20-15S	MS3057-12A
30A□A 40A□A 50A□A	MS3102A24-10P	MS3108B24-10S	MS3106B24-10S	MS3057-16A
SGMG- 05A□A 09A□A 13A□A	MS3102A20-15P	MS3108B20-15S	MS3106B20-15S	MS3057-12A
20A□A 30A□A 44A□A	MS3102A24-10P	MS3108B24-10S	MS3106B24-10S	MS3057-16A
55A□A 75A□A 1AA□A 1EA□A	MS3102A32-17P MS3102A10SL-3P	MS3108B32-17S MS3108B10SL-3S	MS3106B32-17S MS3106A10SL-3S	MS3057-20A MS3057-4A
SGMG- 03A□B 06A□B 09A□B	MS3102A20-15P	MS3108B20-15S	MS3106B20-15S	MS3057-12A
12A□B 20A□B 30A□B	MS3102A24-10P	MS3108B24-10S	MS3106B24-10S	MS3057-16A
44A□B 60A□B	MS3102A32-17P MS3102A10SL-3P	MS3108B32-17S MS3108B10SL-3S	MS3106B32-17S MS3106A10SL-3S	MS3057-20A MS3057-4A
SGMD- 22A□A 32A□A 40A□A	MS3102A24-10P	MS3108B24-10S	MS3106B24-10S	MS3057-16A

Connector on motor end already provided

Provided by the user. (Cable end)

Note When two models are listed, the top connector model is for the Servomotor and the bottom connector model is for the brake.

● Connectors for IP67-compatible Environment

The following table shows connectors for Servomotors (without brake).

Servomotor Model	Receptacle	Plug	End Bell: Japan Aviation Electronics Industry, Ltd. Back Shell: Daiichi Denshi Kogyo Co., Ltd.		Cable Clamp	Manufacturer
			Angle (L-shaped)	Straight		
SGMS- 10A□A 15A□A 20A□A 30A□A 40A□A 50A□A	CE05-2A18 -10PD	MS3106A18-1 0S (D190)	CE-18BA-S	CE02-18BS-S	CE3057-10A-*	Daiichi Denshi Kogyo Co., Ltd.
	JL04HV-2E22- 22PE-B	JL04V-6A22-2 2SE	JL04-22EBL	JL04-22EB	JL04-2022CK (14)	Japan Aviation Electronics Industry, Ltd.
SGMG- 05A□A 09A□A 13A□A 20A□A 30A□A 44A□A 55A□A 75A□A 1AA□A 1EA□A	CE05-2A18 -10PD	MS3106A18-1 0S (D190)	CE-18BA-S	CE02-18BS-S	CE3057-10A-	Daiichi Denshi Kogyo Co., Ltd.
	JL04HV-2E22- 22PE-B	JL04V-6A22-2 2SE	JL04-22EBL	JL04-22EB	JL04-2022CK (14)	Japan Aviation Electronics Industry, Ltd.
JL04V-2E32 -17PE-B	JL04V-6A32-1 7SE	*	*	*	Japan Aviation Electronics Industry, Ltd.	
SGMG- 03A□B 06A□B 09A□B 12A□B 20A□B 30A□B 44A□B 60A□B	CE05-2A18 -10PD	MS3106A18-1 0S (D190)	CE-18BA-S	CE02-18BS-S	CE3057-10A-*	Daiichi Denshi Kogyo Co., Ltd.
	JL04HV-2E22- 22PE-B	JL04-6A22-22 S	JL04-22EBL	JL04-22EB	JL04-2022CK (14)	Japan Aviation Electronics Industry, Ltd.
JL04V-2E32 -17PE-B	JL04V-6A32-1 7SE	*	*	*	Japan Aviation Electronics Industry, Ltd.	
SGMD- 22A□A 32A□A 40A□A	JL04V-2E24 -10PE-B	JL04-6A24-10 S	JL04-24EBL	JL04-24EB	JL04-2428CK (17)	Japan Aviation Electronics Industry, Ltd.

Connector
on motor
end already
provided

Provided by the user.

* Use flexible conduit (Japan Aviation Electronics Industry, Ltd.) for the motor section of SGMG-55A□A, -75A□A, -1AA□A, -1EA□A, -44A□B and -60A□B Servomotors because they do not have end bells.

Note 1 Do not modify the receptacle and plug combination in order to conform to IP67 specifications.

2 End bell is the name of a product manufactured by Japan Aviation Electronics Industry, Ltd. and back shell is the name of a product manufactured by Daiichi Denshi Kogyo Company.

3 Select cable clamps marked with an asterisk (*) based on wire diameter.

4 Select plugs only with flexible conduits.

The following table shows connectors for Servomotors (with brake).

Servomotor Model	Receptacle	Plug	End Bell: Japan Aviation Electronics Industry, Ltd. Back Shell: Daiichi Denshi Kogyo Co., Ltd.		Cable Clamp	Manufacturer
			Angle (L-shaped)	Straight		
SGMS- 10A□A 15A□A 20A□A 30A□A 40A□A 50A□A	JL04V-2E20-15 PE-B	JL04V-6A20-1 5SE	JL04-20EBL	JL04-20EB	JL04-2022CK (14)	Japan Aviation Electronics Industry, Ltd.
	JL04V-2E24-10 PE	JL04V-6A24-1 0SE	JL04-24EBL	JL04-24EB	JL04-2428CK (17)	Japan Aviation Electronics Industry, Ltd.
SGMG- 05A□A 09A□A 13A□A 20A□A 30A□A 44A□A 55A□A 75A□A 1AA□A 1EA□A	JL04V-2E20-15 PE	JL04V-6A20-1 5SE	JL04-20EBL	JL04-20EB	JL04-2022CK (14)	Japan Aviation Electronics Industry, Ltd.
	JL04V-2E24-10 PE-B	JL04-6A24-10 S	JL04-24EBL	JL04-24EB	JL04-2428CK (17)	Japan Aviation Electronics Industry, Ltd.
	JL04V-2E32-17 PE-B CE05-2A10SL-3PC	JL04V-6A32-1 7SE MS3106A10S L-3S (D190) *1	CE-10SLBA-S *1,2	CE05-10SLBS-S *1,2	CE3057-4A-1 *1,2	Japan Aviation Electronics Industry, Ltd. Daiichi Denshi Kogyo Co., Ltd.
SGMG- 03A□B 06A□B 09A□B 12A□B 20A□B 30A□B 44A□B 60A□B	JL04V-2E20-15 PE	JL04V-6A20-1 5SE	JL04-20EBL	JL04-20EB	JL04-2022CK (14)	Japan Aviation Electronics Industry, Ltd. Daiichi Denshi Kogyo Co., Ltd.
	JL04V-2E24-10 PE-B	JL04V-6A24-1 0S	JL04-24EBL	JL04-24EB	JL04-2428CK (17)	Japan Aviation Electronics Industry, Ltd.
	JL04V-2E32-17 PE-B CE05-2A10SL-3PC	JL04V-6A32-1 7SE MS3106A10S L-3S (D190) *1	CE-10SLBA-S *1,2	CE05-10SLBS-S *1,2	CE3057-4A-1 *1,2	Japan Aviation Electronics Industry, Ltd. Daiichi Denshi Kogyo Co., Ltd.
SGMD- 22A□A 32A□A 40A□A	JL04V-2E24-10 PE-B	JL04-6A24-10 S	JL04-24EBL	JL04-24EB	JL04-2428CK (17)	Japan Aviation Electronics Industry, Ltd.

Connector on motor end already provided

Provided by the user.

* 1 L-shaped and straight plugs are both compatible with holding brake (Daiichi Denshi Kogyo Co., Ltd.). End Bell is the name of a product manufactured by Japan Aviation Electronics Industry, Ltd. and Back Shell is the name of a product manufactured by Daiichi Denshi Kogyo Company.

* 2 Use flexible conduit for the motor section of SGMG-55A□A, -75A□A, -1AA□A, -44A□B and -60A□B Servomotors because they do not have end bells. (Japan Aviation Electronics Industry, Ltd.)

Note 1 Do not modify the receptacle and plug combination in order to conform to IP67 specifications.

2 Select plug only with a flexible conduit.

MS (D190) Series: MS3106A20-29S (D190) Plug for Conduits

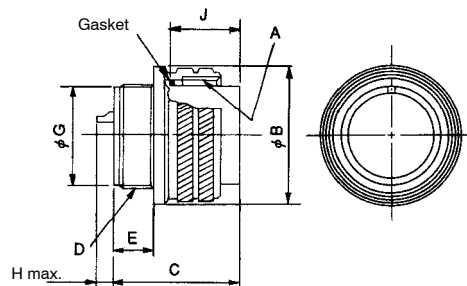

[mm (in)]

Shell Size	A	$\phi B \begin{smallmatrix} +0 \\ -0.38 \end{smallmatrix} (0.015)$	$C \pm 0.5$ (0.020)	D	$E \pm 0.3$ (0.012)	$\phi G \begin{smallmatrix} +0.05 (0.0020) \\ -0.25 (0.0098) \end{smallmatrix}$	$J \pm 0.12$ (0.0047)
10SL	5/8-24UNEF-2B	22.22 (0.875)	23.3 (0.917)	9/16-24UNEF-2A	7.5 (0.30)	12.5 (0.492)	13.49 (0.531)
20	1 1/4-18UNEF-2B	37.28 (1.468)	34.11 (1.343)	1 1/8-18UNEF-2A	12.16 (0.479)	26.8 (1.055)	18.26 (0.718)

Manufactured by Daiichi Denshi Kogyo Co., Ltd.

CE02-XXBS-S Straight Back Shell for the MS (D190)

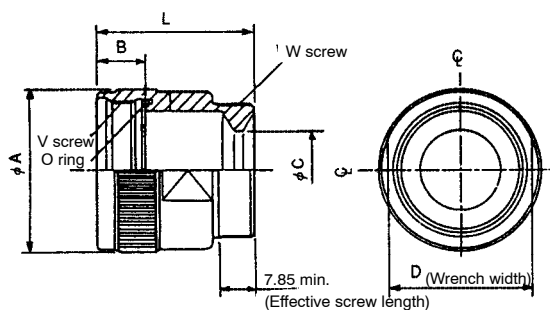

[mm (in)]

Shell Size	Name	L	ϕA	B	ϕC	D	V	W
18	CE02-18BS-S	31 (1.22)	30.5 (1.20)	10.5 (0.413)	16.3 (0.642)	26.7 (1.05)	1-20UNEF-2B	1-20UNEF-2A
20	CE02-20BS-S	35 (1.38)	35 (1.38)	10.9 (0.429)	17.8 (0.700)	31.6 (1.24)	1 1/8-18UNEF-2B	1 3/16-18UNEF-2A

Manufactured by Daiichi Denshi Kogyo Co., Ltd.

CE-XXBA-S (XXX) Angled Back Shell for the MS (D190)

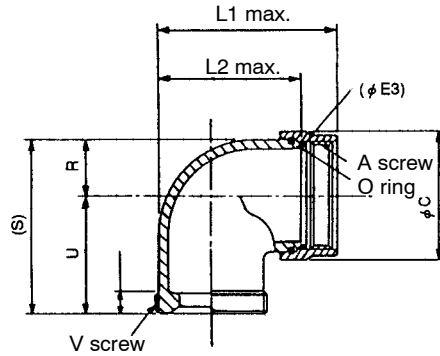

[mm (in)]

Part Number	Shell Size	Joint Screw A	Overall Length L1	Overall Length of Angle Body L2	Outside Diameter of Coupling C	R	U	(S)	Cable Clamp Mounting Screw V	Effective Screw Length W
CE-10SLBA-S	10SL	9/16-24UNEF-2B	30.6 (1.20)	22.5 (0.885)	21.7 (0.854)	7.9 (0.31)	21 (0.83)	28.9 (1.14)	5/8-24UNEF-2A	7.5 (0.30)
CE-18BA-S	18	1-20UNEF-2B	44.6 (1.76)	34 (1.34)	32.4 (1.28)	13.2 (0.520)	30.2 (1.19)	43.4 (1.71)	1-20UNEF-2A	7.5 (0.30)
CE-20BA-S	20	1 1/18UNEF-2B	50.5 (1.99)	39.6 (1.56)	36 (1.42)	15 (0.591)	33.3 (1.31)	48.3 (1.90)	1 3/16-18UNEF-2A	7.5 (0.30)

Manufactured by Daiichi Denshi Kogyo Co., Ltd.

CE3057-XXA Waterproof Cable Clamp with Rubber Bushing for the MS (D190)

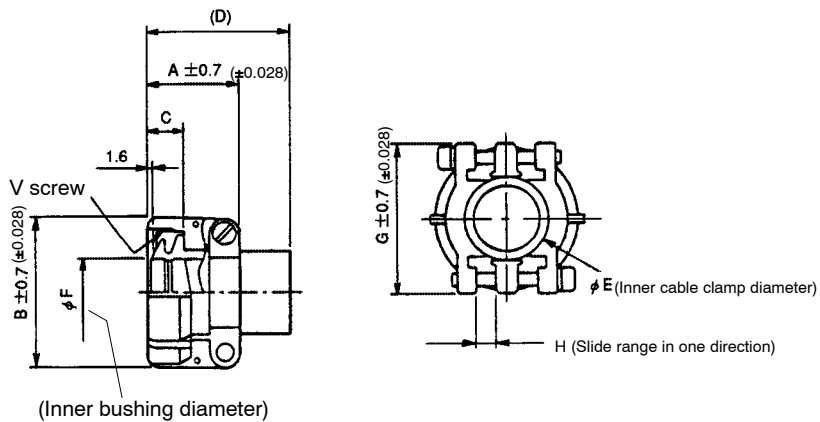

[mm (in)]

Part Number	Shell Size	Overall Length A	Outer Diameter B	Effective Screw Length C	(D)	E	F	G	H	Mounting Screw V	Added Bushing	Applicable Cable Range (For Reference)	
CE3057-4A-1	10SL	20.6 (0.811)	20.6 (0.811)	10.3 (0.406)	41.3 (1.63)	7.9 (0.311)	5.6 (0.220)	22.2 (0.874)	1.6 (0.063)	5/8-24UNEF-2B	CE3420-4-1	φ3.6 (φ0.14) to φ5.6 (φ0.22)	
CE3057-10A-1	18	23.8 (0.937)	30.1 (1.19)	10.3 (0.406)	41.3 (1.63)	15.9 (0.626)	14.1 (0.555)	31.7 (1.25)	3.2 (0.13)	1-20UNEF-2B	CE3420-10-1	φ10.5 (φ0.41) to φ14.1 (φ0.56)	
CE3057-10A-2							11.6 (0.457)					CE3420-10-2	φ8.5 (φ0.33) to φ11 (φ0.43)
CE3057-10A-3							8.7 (0.34)					CE3420-10-3	φ5.5 (φ0.22) to φ9.7 (φ0.38)
CE3057-12A-1	20 22	23.8 (0.937)	35 (1.38)	10.3 (0.406)	41.3 (1.63)	19 (0.748)	16 (0.63)	37.3 (1.47)	4 (0.16)	1 3/16-18UNEF-2B	CE3420-12-1	φ12.5 (φ0.49) to φ16 (φ0.63)	
CE3057-12A-2							13 (0.51)					CE3420-12-2	φ9.5 (φ0.37) to φ13 (φ0.51)
CE3057-12A-3							10 (0.39)					CE3420-12-3	φ6.8 (φ0.27) to φ10 (φ0.39)
CE3057-16A-1	24 28	26.2 (1.03)	42.1 (1.66)	10.3 (0.406)	41.3 (1.63)	23.8 (0.937)	19.1 (0.752)	42.9 (1.69)	4.8 (0.19)	1 7/16-18UNEF-2B	CE3420-16-1	φ15 (φ0.59) to φ19.1 (φ0.75)	
CE3057-16A-2							15.5 (0.610)					CE3420-16-2	φ13 (φ0.51) to φ15.5 (φ0.61)

Manufactured by Daiichi Denshi Kogyo Co., Ltd.

Plug: JL04-6A

Positioning key

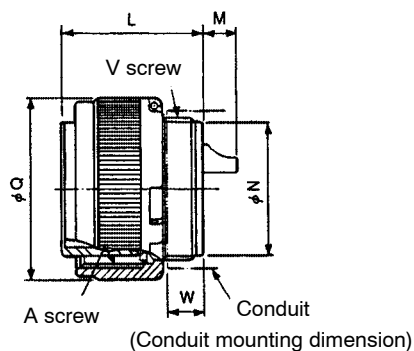
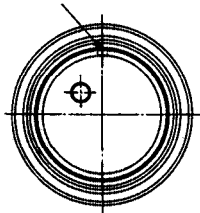

Servodrives Dimensional Drawings

9.4.1 SGMG, SGMS and SGM D Servomotors Connections

[mm (in)]

Shell Size	No. of Cores	Part Name	Joint Screw A Screw	$L_{\pm 0.4}$ (0.00157)	$M_{\pm 0.8}$ (0.0315)	$N_{\pm 0.2}$ (0.0079)	$Q_{\pm 0.8}$ (0.0315)	V Screw	W max.
22	4	JL04-6A22-22S	1 3/8-18UNEF-2B	31.5 (1.24)	7.6 (0.30)	29.6 (1.17)	40.5 (1.59)	1 1/4-18UNEF-2A	8 (0.31)
24	7	JL04-6A24-10S	1 1/2-18UNS-2B	35 (1.38)	5.9 (0.23)	32.8 (1.29)	43.7 (1.72)	1 3/8-18UNEF-2A	10 (0.39)

Manufactured by Daiichi Denshi Kogyo Co., Ltd.

Plug: JL04V-6A

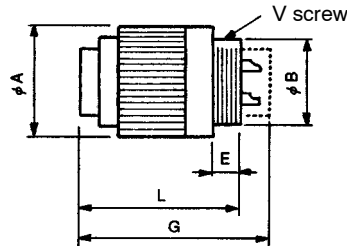

[mm (in)]

Shell Size	V Screw	ϕA	ϕB	L	E	G
20	1 1/8-18UNEF-2A	37.3±0.8 (1.47±0.0315)	27±0.2 (1.06±0.0079)	31.5±0.4 (1.24±0.0157)	8 max. (0.31 max.)	---
32	1 7/8-16UN-2A	56.3±0.8 (2.22±0.0315)	45.4±0.2 (1.79±0.0079)	35.8±0.4 (1.41±0.0157)	10 max. (0.39 max.)	---

Manufactured by Daiichi Denshi Kogyo Co., Ltd.

Straight End Bell: JL04-□□EB

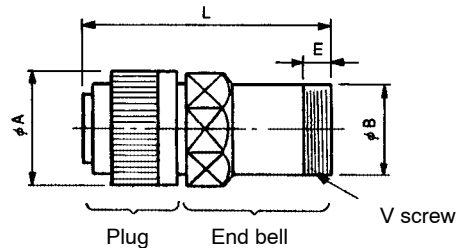

[mm (in)]

Shell Size	V Screw	ϕA	ϕB	L	E
20	1 3/16-18UNEF-2A	37.3±0.8 (1.47±0.0315)	30.05±0.2 (1.18±0.0079)	67.9±0.8 (2.67±0.0315)	8 min. (0.31 min.)
22	1 3/16-18UNEF-2A	40.5±0.8 (1.59±0.0315)	30.05±0.2 (1.18±0.0079)	67.63±0.8 (2.66±0.0315)	8 min. (0.31 min.)
24	1 7/16-18UNEF-2A	43.7±0.8 (1.72±0.0315)	36.4±0.2 (1.43±0.0079)	71±0.8 (2.80±0.0315)	8 min. (0.31 min.)

Manufactured by Daiichi Denshi Kogyo Co., Ltd.

L-shaped End Bell: JL04-□□EBL

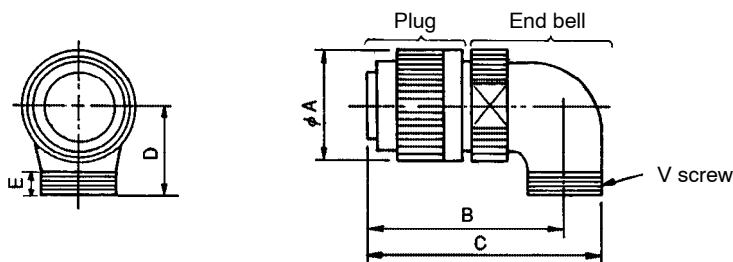

[mm (in)]

Shell Size	V Screw	ϕA	B	C	D	E
20	1 3/16-18UNEF-2A	37.3±0.8 (1.47±0.0315)	60.5±0.8 (2.38±0.0315)	74.2±0.8 (2.92±0.0315)	32±0.8 (1.26±0.0315)	10±0.5 (0.39±0.0179)
22	1 3/16-18UNEF-2A	40.5±0.8 (1.59±0.0315)	60.23±0.8 (2.37±0.0315)	73.93±0.8 (2.91±0.0315)	32±0.8 (1.26±0.0315)	10±0.5 (0.39±0.0179)
24	1 7/16-18UNEF-2A	43.7±0.8 (1.72±0.0315)	65±0.8 (2.56±0.0315)	82±0.8 (3.23±0.0315)	38±0.8 (1.50±0.0315)	10±0.5 (0.39±0.0179)

Cable Clamp: JL04-□□CK(**)

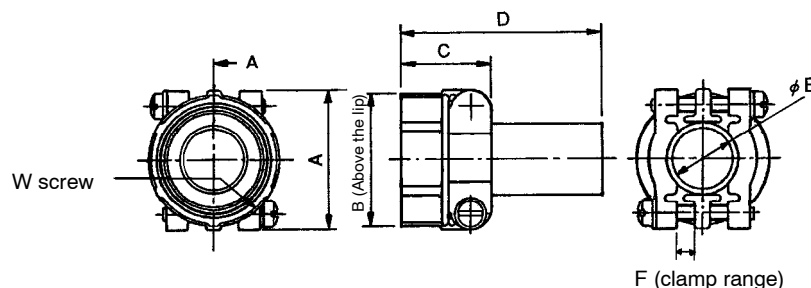

[mm (in)]

Name	Dimensions							
	$A \pm 0.8$ ($A \pm 0.031$)	$B \pm 0.8$ ($B \pm 0.031$)	$C \pm 0.8$ ($C \pm 0.031$)	$D \pm 0.8$ ($D \pm 0.031$)	$\phi E \pm 0.3$ ($\phi E \pm 0.011$)	F	W screw	Applicable Cable Diameter
JL04-2022CK (14)	37.3 (1.47)	34.9 (1.37)	24.3 (0.96)	53.8 (2.12)	15.9 (0.63)	4 (0.16)	1 3/16-18UNEF-2B	$\phi 12.9$ to $\phi 15.9$ ($\phi 0.51$ to $\phi 0.63$)
JL04-2428CK (17)	42.9 (1.69)	42.1 (1.66)	26.2 (1.03)	56.2 (2.21)	18 (0.71)	4.8 (0.19)	1 7/16-18UNEF-2B	$\phi 15$ to $\phi 18$ ($\phi 0.59$ to $\phi 0.71$)

9.4.2 SGM and SGMP Servomotors Connections

A connector kit consists of three connectors as shown below in the diagram: one encoder connector for the Servomotor and SERVOPACK ends of the cable as well as a Servomotor connector for the Servomotor end of the cable.

Encoder connector for the Servomotor end of the cable

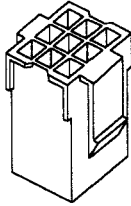

Encoder connector for the SERVOPACK end of the cable

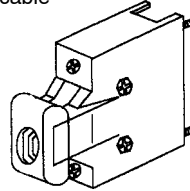

Main Circuit (Power Line) connector on servomotor end cable

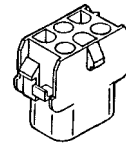

The connectors are classified into four types according to the following:

- Incremental encoder or absolute encoder
- Servomotor with or without brake

A connector kit is required in the following cases:

- Servomotor cable only (whether or not the Servomotor has a brake).
- An encoder cable with a SERVOPACK end connector (loose leads on the encoder end) or an encoder cable only regardless of whether the encoder is incremental or absolute.

Encoder Cable Connectors

Select one of the following two types of encoder cable connectors.

• For Incremental Encoder

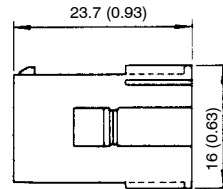
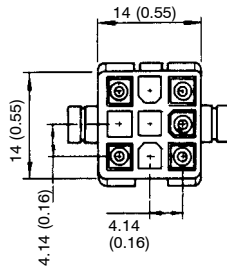

Cap: 172161-1
Socket: 170365-1

• For Absolute Encoder

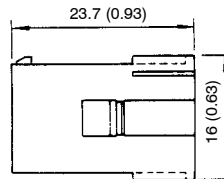
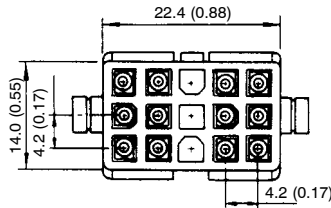

Cap: 172163-1
Socket: 170361-1 or 170365-1

Servomotor Cable Connectors

Select one of the following two models of Servomotor cable connectors.

- For Servomotors without Brake

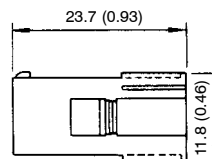
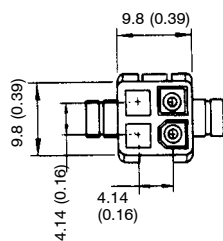

Cap: 172159-1
Socket: 170362-1 or 70366-1

- For Servomotors with Brake

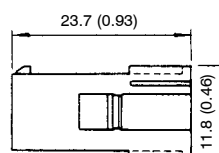
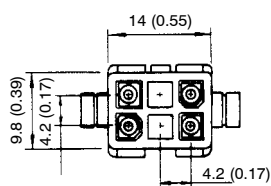

Cap: 172160-1
Socket: 170362-1 or 170366-1

9.4.3 SGMP-15A Servomotor Connectors

Different connectors are used for Servomotors depending on whether Servomotors are with brake or without brake.

- For a Servomotor without a Brake

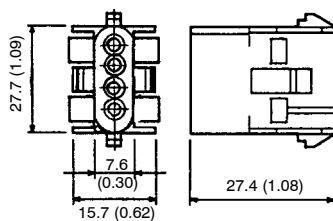

Cap: 350780-1
Socket: 350536-6 or 350550-6

- For a Servomotor with a Brake

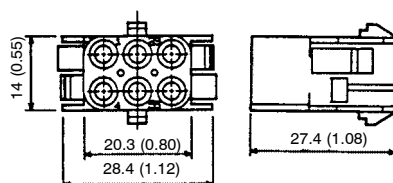

Cap: 350781-1
Socket: 350536-6 or 350550-6

9.4.4 SERVOPACK-end Encoder Connectors

Only one type of encoder connector is available for the SERVOPACK-end encoder common to SGMG, SGMS, SGMD, SGM, and SGMP Servomotors.

■ Connector

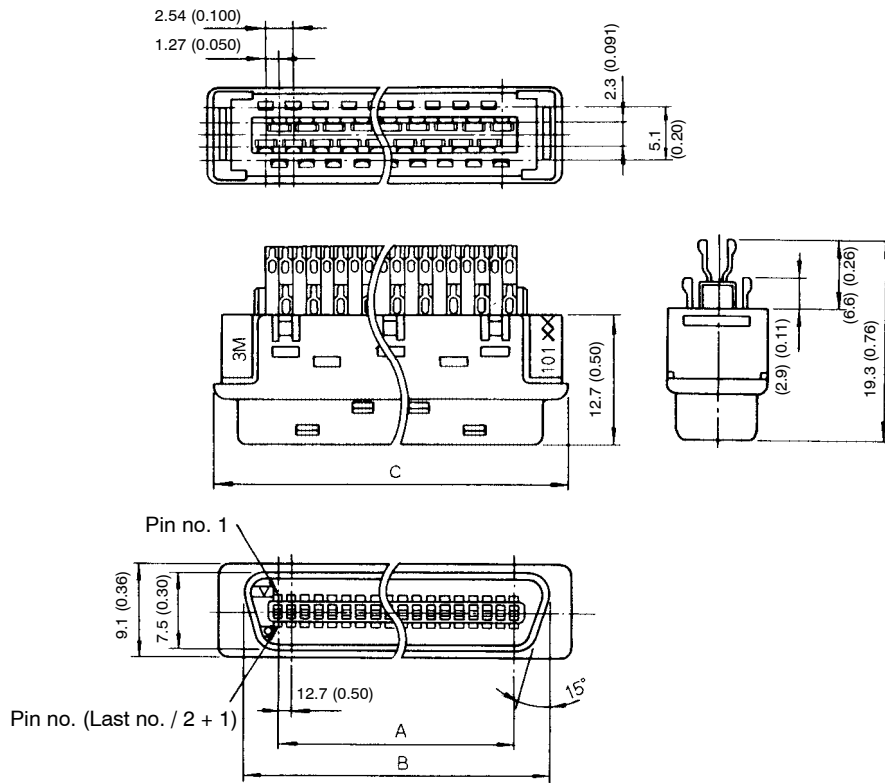

[mm (in)]

Connector Model	A	B	C
10120-3000VE	11.43 (0.45)	17.6 (0.69)	22.0 (0.87)

Manufactured by SUMITOMO 3M, Ltd.

■ Cases

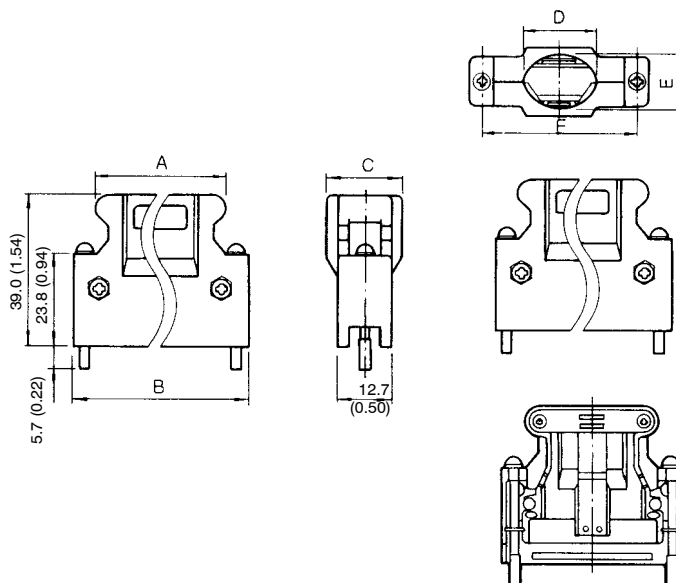

Assembled Connector Diagram (Reference)

[mm (in)]

Model	Connector Model	Case Model	A	B	C	D	E	F
DE9406973	10120-3000VE	10320-52A0-008	22.0 (0.87)	18.0 (0.71)	14.0 (0.55)	12.0 (0.47)	10.0 (0.39)	27.4 (1.08)

Manufactured by SUMITOMO 3M, Ltd.

■ Combination of Connectors

● For SGM and SGMP Servomotor

Connector Kit Model Number	Application		Connector Kit Part List											
	Encoder/Motor Cable		For Encoder Cable								For Motor Cable			
			Encoder End				SERVOPACK End				Cap		Socket	
	Encoder Type	Motor Brake	Cap		Socket		Connector		Case		Model	Qty	Model	Qty
Model			Qty	Model	Qty	Model	Qty	Model	Qty	Model	Qty	Model	Qty	
DP9420006-1	Incremental encoder	Without	172161-1 *1	1	170365-1 *1	10 *3	10120-3000VE *2	1	10320-52A0-008 *2	1	172159-1 *1	1	170366-1 *1	5 *3
DP9420006-2	Incremental encoder	With									172160-1 *1	1		7 *3
DP9420006-3	Absolute encoder	Without	172163-1 *1	1		16 *3					172159-1 *1	1		5 *3
DP9420006-4	Absolute encoder	With									172160-1 *1	1		7 *3

* 1 Manufactured by AMP Co., Ltd.

* 2 Manufactured by SUMITOMO 3M, Ltd.

* 3 Including one spare.

● For SGMP-15A Servomotor

Connector Kit Model Number	Application		Connector Kit Part List											
	Encoder/Motor Cable		For Encoder Cable								For Motor Cable			
	Encoder Type	Motor Brake	Encoder End				SERVOPACK End				Cap		Socket	
			Cap		Socket		Connector		Case		Model	Qty	Model	Qty
		Model	Qty	Model	Qty	Model	Qty	Model	Qty	Model	Qty	Model	Qty	
DP9420016-1	Incremental encoder	Without	172161-1 *1	1	170365-1 *1	10 *3	10120-3000VE *2	1	10320-52A0-008 *2	1	350780-1 *1	1	170366-1 *1	5 *3
DP9420016-2	Incremental encoder	With									350781-1 *1	1		7 *3
DP9420016-3	Absolute encoder	Without	172163-1 *1	1		16 *3					350780-1 *1	1		5 *3
DP9420016-4	Absolute encoder	With									350781-1 *1	1		7 *3

* 1 Manufactured by AMP.

* 2 Manufactured by SUMITOMO 3M, Ltd.

* 3 Including one spare.

9.4.5 1CN, 2CN Connector for SERVOPACK

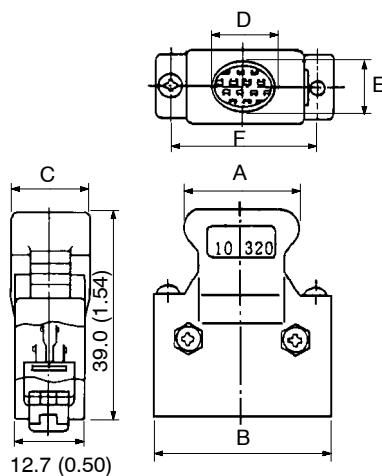

[mm (in)]

SERVOPACK	Connector	Case	A	B	C	D	E	F
1CN	10126-3000VE	10326-52A0-008	25.8 (1.02)	37.2 (1.46)	14.0 (0.55)	12.0 (0.47)	10.0 (0.39)	31.3 (1.23)
2CN	10120-3000VE	10320-52A0-008	22.0 (0.87)	33.3 (1.31)	14.0 (0.56)	12.0 (0.47)	10.0 (0.39)	27.4 (1.08)

9.4.6 4CN Connector for SERVOPACK

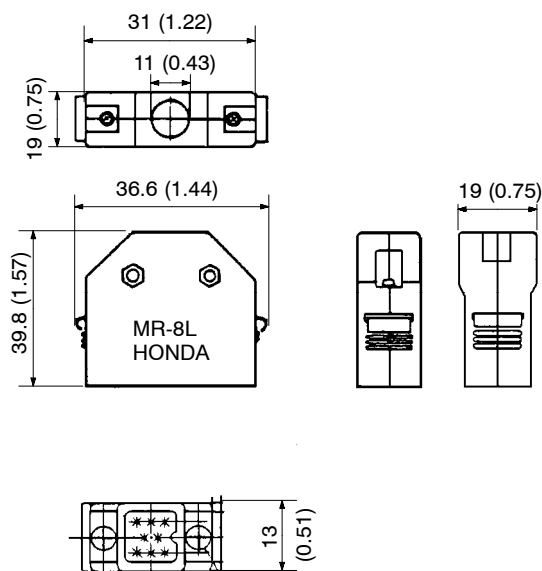

Connector Kit Model	Application	Connector Kit Part List			
		Connector		Case	
		Model	Qty	Model	Qty
DE9411354	1CN connector for I/O	10126-3000VE* ²	1	10326-52A0-008* ²	1 set
DE9411357	4CN MECHATROLINK communication connector	MR-8F* ⁴	1	MR-8L* ⁴	1 set

* 1 Manufactured by AMP Co., Ltd.

* 2 Manufactured by SUMITOMO 3M, Ltd.

* 3 Including one spare.

* 4 Manufactured by Honda Tsushin Kogyo Co., Ltd.

[mm (in)]

Parts Name	A	B	C	D	E	F	G	H	I	J
LF-310	180 (7.09)	170 (6.69)	60 (2.36)	25 (0.98)	120 (4.72)	135 (5.31)	150 (5.91)	35 (1.38)	65 (2.56)	4.5×7 (0.18× 0.28)
LF-315	180 (7.09)	170 (6.69)	60 (2.36)	25 (0.98)	120 (4.72)	135 (5.31)	150 (5.91)	35 (1.38)	65 (2.56)	4.5×7 (0.18× 0.28)
LF-320	180 (7.09)	170 (6.69)	60 (2.36)	29 (1.14)	120 (4.72)	135 (5.31)	150 (5.91)	35 (1.38)	65 (2.56)	4.5×7 (0.18× 0.28)
LF-330	180 (7.09)	170 (6.69)	60 (2.36)	29 (1.14)	120 (4.72)	135 (5.31)	150 (5.91)	35 (1.38)	65 (2.56)	4.5×7 (0.18× 0.28)
LF-340	180 (7.09)	160 (6.30)	50 (1.97)	30 (1.18)	200 (7.87)	220 (8.66)	240 (9.45)	40 (1.57)	80 (3.15)	6.5×9 (0.26× 0.35)
LF-350	180 (7.09)	160 (6.30)	50 (1.97)	30 (1.18)	200 (7.87)	220 (8.66)	240 (9.45)	40 (1.57)	80 (3.15)	6.5×9 (0.26× 0.35)
LF-360	200 (7.87)	180 (7.09)	60 (2.36)	30 (1.18)	300 (7.87)	320 (12.60)	340 (9.45)	40 (1.57)	100 (3.94)	6.5×9 (0.26× 0.35)

• LF-K Series (Three-phase 200 VAC Class)

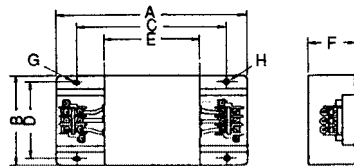

[mm (in)]

Parts Name	Terminal Block	A	B	C	D	E	F	G	H
LF-380K	TE-K22 M6	670 (26.38)	400 (15.75)	560 (22.05)	380 (14.96)	500 (19.69)	170 (6.69)	9 × φ6.5 (0.35 × φ0.26)	φ6.5 (φ0.26)

9.6 Peripheral Devices

9.6.1 Connector Terminal Block Converter Unit

■ JUSP-TA26P

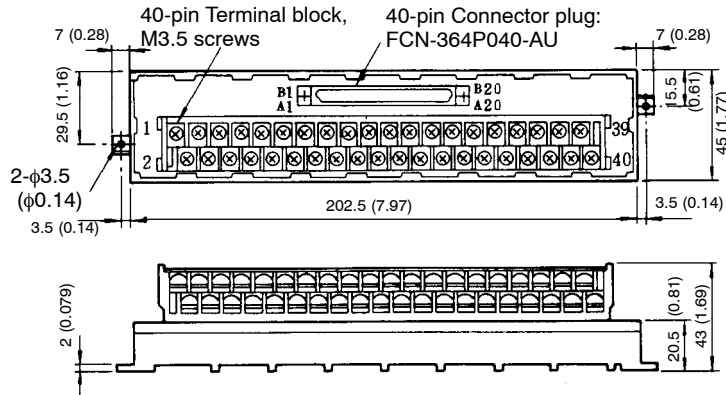

9.6.2 Brake Power Supply

Brake power supplies are used for Servomotors with brake.

Brake power supplies are available for 200 V and 100 V inputs.

- 200 VAC input: LPSE-2H01
100 VAC input: LPDE-1H01

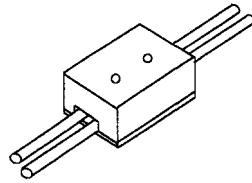

■ Dimensional Diagram

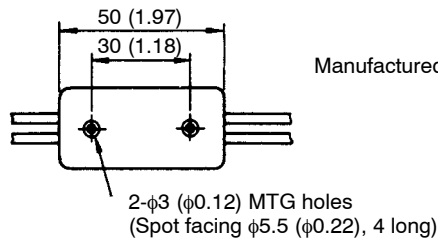

Manufactured by Yaskawa Controls Co., Ltd.

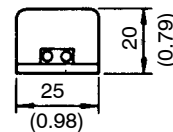
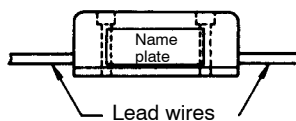

■ Specifications

- Lead Wire Length: 500 mm (19.69 in) each
- Max. Ambient Temperature: 60°C
- Lead Wires: Color coded

AC Input		Brake
100 V	200 V	
Blue, White	Yellow, White	Red, Black

The following diagrams show the internal circuits. While it is possible to switch either the AC or DC side of the brake power supply, it is normally safer to switch the AC side. If the DC side is to be switched, install a surge suppressor near the brake coil to prevent the surge voltages due to switching the DC side from damaging the brake coil.

• Internal Circuit for 200-VAC Input (LPSE-2H01)

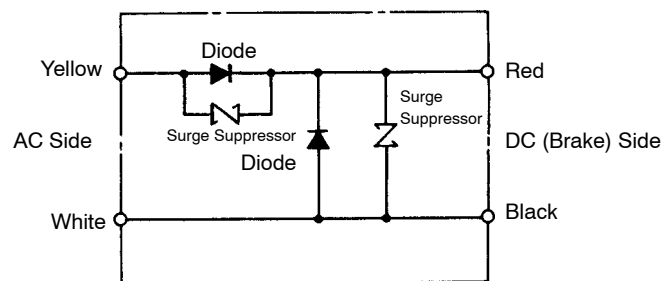

• Internal Circuit for 100-VAC Input (LPDE-1H01)

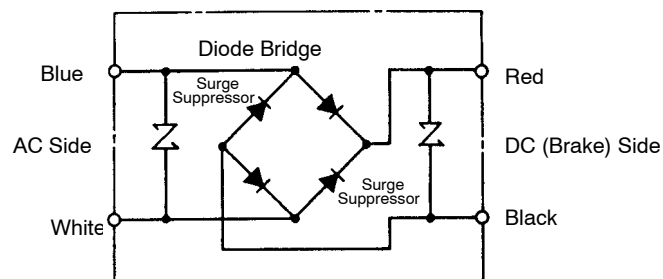

9.6.3 Molded-case Circuit Breaker

The user must provide a molded-case circuit breaker (MCCB) based on an appropriate capacity to protect the power supply line.

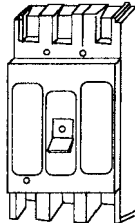

- Recommended product

Ground fault encoder for Servomotor protection
 manufactured by Mitsubishi Electric Co., Ltd.
 Model: MIN50-CF





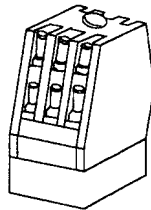

9.6.4 Magnetic Contactor

Magnetic contactors are used to turn the servo power supply ON and OFF. Be sure to attach a surge suppressor to the magnetic contactor.

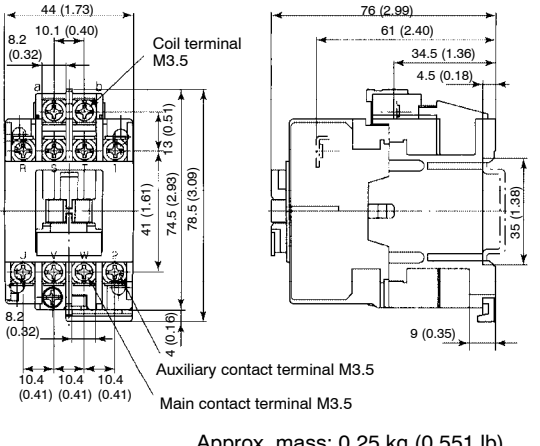
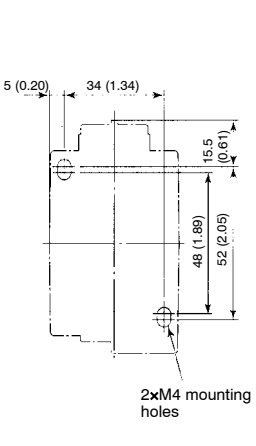
Select a magnetic contactor based on the current capacity of the SGDB SERVOPACK. For multiple servo systems, select a contactor based on total current capacity.

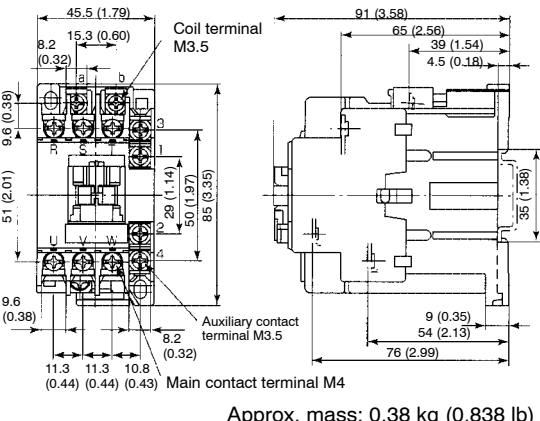
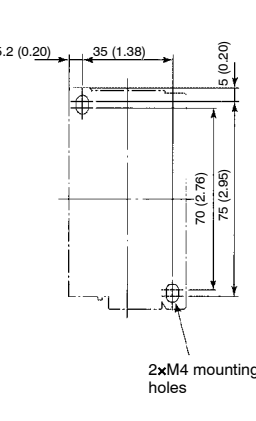
The following table shows external dimensions, terminal symbols, etc.

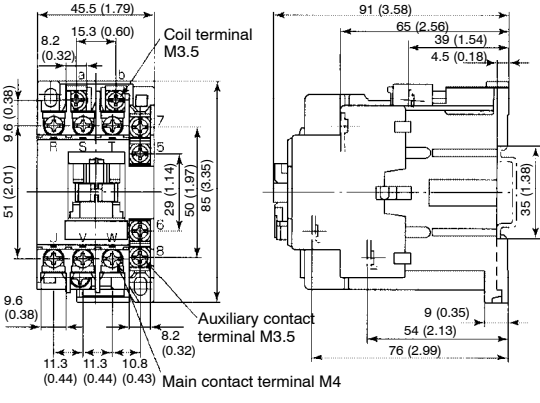
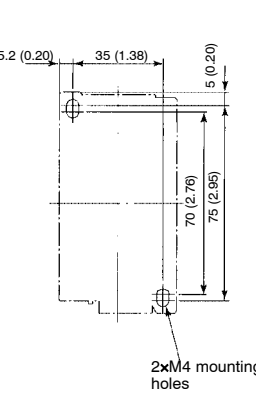

Model	External Dimensions [mm (in)]	Mounting Hole Dimensions [mm (in)]	Terminal Symbols
HI-11J HI-14J	 <p>Coil terminal M3.5</p> <p>Auxiliary contact terminal M3.5</p> <p>Main contact terminal M3.5</p> <p>Approx. mass: 0.25 kg (0.551 lb)</p>	 <p>2xM4 mounting holes</p>	<p>Auxiliary NO contact</p> <p>a A1  A2 b</p> <p>R 1 S 3 T 5 1 13</p> <p>U 2 V 4 W 6 2 14</p> <p>Auxiliary NC contact</p> <p>a A1  A2 b</p> <p>R 1 S 3 T 5 1 11</p> <p>U 2 V 4 W 6 2 12</p>
HI-15J HI-18J	 <p>Coil terminal M3.5</p> <p>Auxiliary contact terminal M3.5</p> <p>Main contact terminal M4</p> <p>Approx. mass: 0.38 kg (0.838 lb)</p>	 <p>2xM4 mounting holes</p>	<p>Auxiliary NO contact/ Auxiliary NC contact</p> <p>a A1  A2 b</p> <p>R 1 S 3 T 5 1 21 3 13</p> <p>U 2 V 4 W 6 2 22 4 14</p>
HI-20J	 <p>Coil terminal M3.5</p> <p>Auxiliary contact terminal M3.5</p> <p>Main contact terminal M4</p> <p>Approx. mass: 0.38 kg (0.838 lb)</p>	 <p>2xM4 mounting holes</p>	<p>Auxiliary NO contact/ Auxiliary NC contact</p> <p>a A1  A2 b</p> <p>R 1 S 3 T 5 5 41 7 23</p> <p>U 2 V 4 W 6 6 42 8 24</p>

9.6.6 Regenerative Resistor Unit

Model	External Dimensions [mm (in)]	Mounting Hole Dimensions [mm (in)]	Terminal Symbols
HI-25J HI-35J	<p>Approx. mass: 0.68 kg (1.499 lb)</p>	<p>2xM4 mounting holes</p>	<p>Auxiliary NO contact/ Auxiliary NC contact</p>

* The magnetic contactor is manufactured by Yaskawa Controls.

9.6.5 Surge Suppressor

Attach a surge suppressor to the magnetic contactor to prevent power supply noise and to protect contacts.

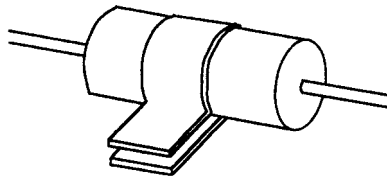

- Recommended product

Spark Killer manufactured by Okaya Electric Industries Co., Ltd.
 Model: CR50500BA (250 VAC)
 Static electricity capacity: 0.5 μ F \pm 20%
 Resistance :50 Ω (1/2W) \pm 30%

9.6.6 Regenerative Resistor Unit

Externally mount a regenerative resistor to SERVOPACKS with a 5.5 kW or higher capacity (SGDB-60 or higher) in order to consume regenerative electric energy. One of the following regenerative resistor units is needed depending on the model of SERVOPACK.

SGDB SERVOPACK Model	Regenerative Resistor Unit Model
60AN	JUSP-RA04
75AN	JUSP-RA05
1AAN	
1EAN	

■ Dimensional Diagram

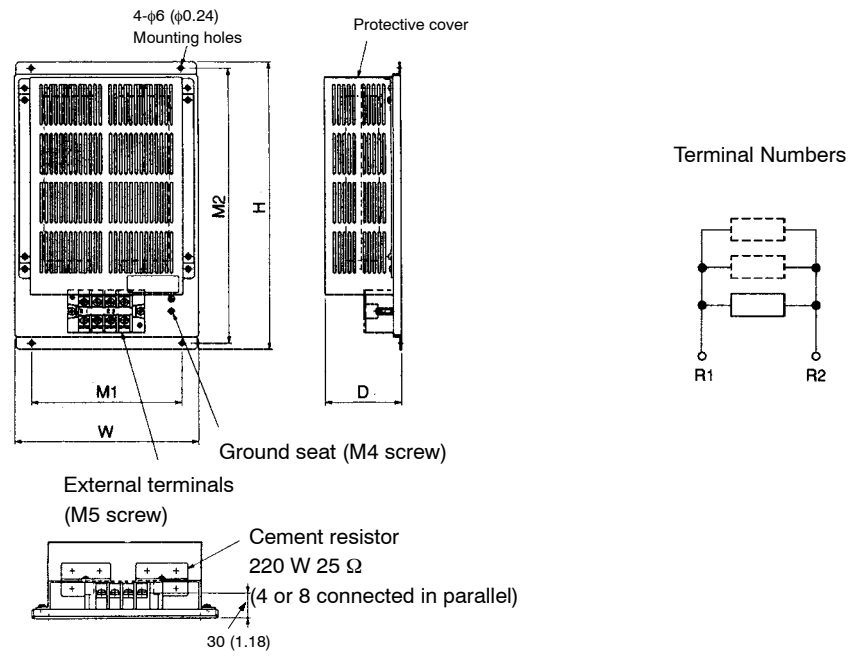

[mm (in)]

Model	W	H	D	M1	M2	Approx. Mass
JUSP-RA04	220 (8.66)	350 (13.78)	92 (3.62)	180 (7.09)	335 (13.19)	4 kg (8.819 lb)
JUSP-RA05	300 (11.81)	350 (13.78)	95 (3.74)	250 (9.84)	335 (13.19)	7 kg (15.432 lb)

9.6.7 Analog Monitor Cable

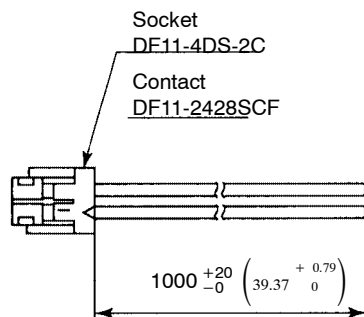

Model	L mm (in)
DE9404559	1000^{+20}_{-0} $\left(39.37^{+0.79}_{-0} \right)$

10

Trial Operation

This chapter describes items to be inspected and checked prior to trial operation and also the procedure for trial operation.

10.1	Check Items before Trial Operation	10 -2
10.1.1	Servomotors	10 -2
10.1.2	SERVOPACKS	10 -2
10.2	Trial Operation Procedure	10 -3
10.2.1	Preparations for Trial Operation	10 -3
10.2.2	Operating the Servodrive	10 -4
10.2.3	Trial Operation Inspection	10 -4

10.1 Check Items before Trial Operation

Inspect and check the following items when performing trial operation, and be sure to conduct trial operation safely.

10.1.1 Servomotors

Inspect the following items before conducting trial operation. Also conduct the inspections according to *Chapter 12 “Maintenance and Inspection”* if conducting trial operation on Servomotors that have been stored for a long period of time.

- Connection to machines or devices, wiring and grounding are correct.
- Are bolts and nuts securely tightened?
- Is the oil seal undamaged and oiled?

Take appropriate action immediately if one of the items above is incorrect.

10.1.2 SERVOPACKS

Inspect the following items before conducting trial operation.

- User constants are properly set for the applicable Servomotor and specifications
- Terminal connections and wiring leads are tightened securely and connectors are inserted securely.
- The power supply turns OFF if servo alarm occurs.
- Voltage supplied to the SERVOPACK is 200 to 230 V $\begin{matrix} +10 \\ -15 \end{matrix}$ % .
(When using a power supply that is not 200 V, a transformer that steps down to 200 V must be installed separately.)

Take appropriate action immediately if an alarm occurs or one of the items above is incorrect.

10.2 Trial Operation Procedure

10.2.1 Preparations for Trial Operation

IMPORTANT

To prevent accidents, initially conduct trial operation with no load connected to the Servomotor. If the trial operation must be conducted while connected to equipment, be sure to set up the system so that an emergency stop is available if needed.

10

Prepare operation according to the following procedure.

1. Turn the power ON.
If the power ON/OFF circuit is configured as shown in *Section 5.1 “Turning Power ON/OFF”*, press the ON switch to turn ON power. Press and hold the switch for about two seconds with the configuration shown in *Figure 5.1 of Section 5.1*.
2. If the SERVOPACK turns ON normally, the green power-ON indicator will light. After the CONNECT (establish connection) command is transferred, the red alarm indicator will go out. Use the SMON (status monitoring) command to check SERVOPACK status. The data returned from the SERVOPACK is alarm code 99.
3. Use the IR_RD (read ID) command to check the SERVOPACK type. The SERVOPACK returns “SGDB-***N.”
4. Transfer the parameters required for trial operation (such as motor selection, encoder type*, and encoder pulses) by PRM_WR (write parameter) command.
5. Transfer a SENS_ON (encoder power ON) command and verify that no alarm has occurred. Position data is also received with an absolute encoder.
6. When the SV_ON (Servo ON) command is transferred, the main circuit in the SERVOPACK is activated and the Servomotor is ready to drive. If the SMON command is transferred, status SVON = 1 (base driving) will be returned.

* As factory settings, the motor is set to an SGMG (1500 r/min.) motor and the encoder is set to an incremental encoder (8192 P/R). When using any other motors, the parameters must be changed.

10.2.2 Operating the Servodrive

Driving a Servomotor is possible only when the main circuit is in active base driving. Run the Servomotor at low speed.

■ Command Transmission Example

POSING (rapid traverse positioning) command

Option = 0

Positioning setting = 10000 (current position +10000 with absolute encoders)

Rapid traverse speed = 400

Make sure the Servomotor is running in the proper direction according to the reference.

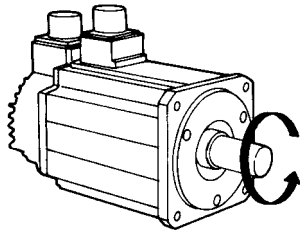

Figure 10.1 Servomotor Forward Running

10.2.3 Trial Operation Inspection

Inspect the following items during the trial operation.

- Abnormal vibration
- Abnormal noise
- Abnormal temperature rise

Take corrective actions referring to *Section 12.2 “Troubleshooting”* if any abnormality is found. Also note that the Servomotor may overload during the trial operation if the load system is not suitable broken in.

11

Settings

This chapter describes default characteristics and servo performance adjustments.

11.1 Characteristics when Shipped	11 -2
11.2 Resetting	11 -2
11.3 Adjusting Servo Performance	11 -2
11.3.1 Setting User Constants	11 -2
11.3.2 Setting Optimum Position and Speed Loop Gain	11 -3

11.1 Characteristics when Shipped

The speed reference (feed speed) characteristics when shipped are as outlined below.

Speed Reference Motor Speed Characteristics

Conditions: No load

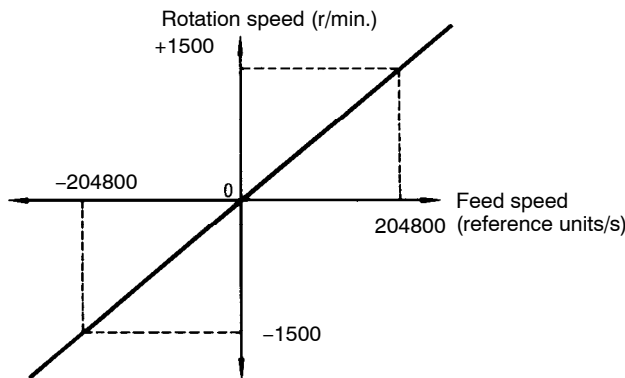

11.2 Resetting

If settings must be reset because of application or usage conditions, reset them in according to *Chapter 6 “MECHATROLINK Communication”*.

11.3 Adjusting Servo Performance

11.3.1 Setting User Constants

■ Position Loop Gain (Cn-001A)

Position loop gain is ideally determined by the specifications of the equipment, but initially set a level lower than the desired value. (The factory setting is 40 (1/s).)

■ Load Inertia (Cn-0003)

Set the load inertia for the moment of inertia ratio on motor shaft. (This constant is factory set to 100 (%), which is equivalent to the motor inertia.)

■ Speed Loop Gain (Cn-0004)

The setting (Hz) of Cn-0004 expresses the speed loop gain characteristics, and is the cutoff frequency “ f_c ” for the response characteristics of a system with balanced inertia. The value f_c may vary even with the same speed loop gain setting due to fluctuations in load inertia.

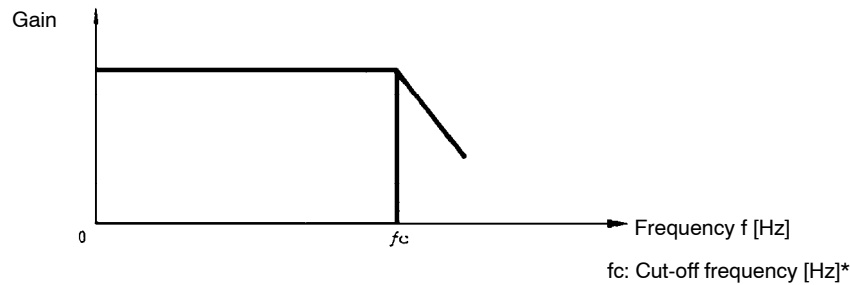

* The factory setting is 40 [Hz].

Note Set load inertia (Cn-0003) to 0 (%) so that speed loop gain (Cn-0004) will be 40 (Hz) or less if the Servomotor is running under no-load conditions.

■ Speed Loop Integration Time Constant (Cn-0005)

Set Cn-0005 to 20 (ms). (Factory setting)

11.3.2 Setting Optimum Position and Speed Loop Gain

■ Speed Overshooting and Vibration

- Incrementally decrease the position loop gain (Cn-001A).
- Incrementally increase the speed loop gain. If the situation worsens when the speed loop gain is increased, incrementally decrease the gain.
- A certain amount of position loop gain is necessary, so set the acceleration/deceleration time (Cn-001F to Cn-0021) high if the application cannot handle overshoot.

■ When Response Tracking Worsens

- Incrementally increase the position loop gain (Cn-001A).
- If the position loop gain cannot be increased any higher because of vibration, incrementally increase the speed loop gain (Cn-0004).

If increasing the speed loop gain causes vibration, then tracking performance including that for the mechanical system is at its limit.

12

Maintenance and Inspection

This chapter describes maintenance, inspection, and troubleshooting.

12.1	Maintenance and Inspection of Servodrives .	12 -2
12.1.1	Servomotor Inspection	12 -2
12.1.2	SERVOPACK Inspection	12 -3
12.1.3	Replacing the Battery for Absolute Encoders ...	12 -4
12.2	Troubleshooting	12 -5
12.2.1	Servomotors	12 -5
12.2.2	SERVOPACKS	12 -6

12.1 Maintenance and Inspection of Servodrives

12.1.1 Servomotor Inspection

Simple daily inspections are all that are needed to maintain the Servomotor because it is brushless. The inspection and maintenance frequencies given in the following table are only guidelines, and may be increased or decreased to suit driving conditions and environment.

IMPORTANT

Do not disassemble the Servomotor during inspection and maintenance, but rather contact your Yaskawa representative if the Servomotor must be disassembled.

Table 12.1 Maintenance and Inspection Procedure

Item	Frequency	Procedure	Comments
Vibration and Noise	Daily	Touch and listen for irregularities.	The degree of vibration and noise must not be any higher than normal.
Appearance and Cleaning	According to the degree of dirt	Clean with a cloth or compressed air.	---
Insulation Resistance Measurement	Yearly	Disconnect the SERVOPACK and test insulation resistance at 500 V. Must exceed 10 MΩ.	Contact your Yaskawa representative if insulation resistance is below 10 MΩ.
Overhaul	Every 20000 hours or 5 years	Remove the Servomotor, replace consumable parts and perform any necessary repairs.	Contact your Yaskawa representative for the overhaul.
Oil seal replacement (for Motors equipped with oil seals)	Every 5000 hours	Remove the Servomotor and replace the oil seal.	---

■ Guidelines for Replacing Parts

The following parts are subject to mechanical wear or deterioration over time. To avoid failure, replace these parts periodically as indicated below.

Table 12.2 Parts Replacement

Part	Standard Replacement Period	Replacement Method
Bearings	20000 operating hours	Disassemble the Servomotor and replace the bearings if necessary.
Oil Seal	About 5000 hours	Replace with a new oil seal.

12.1.2 SERVOPACK Inspection

The SERVOPACK contains highly reliable parts and does not require daily inspection. Always inspect the SERVOPACK at least once a year. Be sure to check user settings prior to operation because we reset user constants to standard settings when we ship overhauled SERVOPACKS.

Table 12.3 Inspection Items

Item	Frequency	Procedure	Remedy
Clean Unit Interior and Circuit Boards	Yearly	Check for dust, dirt, and oil on surfaces.	Clean with a cloth or compressed air.
Loose Screws	Yearly	Check for loose terminal block and connector screws.	Tighten any loose screws.
Defective Parts in Unit or on Circuit Boards	Yearly	Check for discoloration, damage or broken wires due to heat.	Contact your Yaskawa representative.

■ Guidelines for Replacing Parts

The following parts are subject to mechanical wear or deterioration over time. To avoid failure, replace these parts at the frequency indicated in the following table.

Table 12.4 Parts Replacement

Part	Standard Replacement Period	Replacement Method
Cooling fan	4 to 5 years	Replace with a new fan.
Smoothing Capacitor	7 to 8 years	Test and replace with a new capacitor if necessary.
Relays	–	Test and replace if necessary.
Fuse	10 years	Replace with a new fuse.
Aluminum Electrolytic Capacitor on Circuit Board	5 years	Test and replace with a new circuit board if necessary.

Note Operating conditions

Ambient temperature: Annual average of 30°C

Load factor: 80% max.

Operation rate: 20 hours/day max.

Be sure to check user settings prior to operation because Yaskawa resets user constants to factory settings when shipping overhauled SERVOPACKS.

12.1.3 Replacing the Battery for Absolute Encoders

Replace the absolute encoder battery (purchased by the user) as outlined below. With an ER 6-V C-type lithium battery manufactured by Toshiba Battery Co., Ltd. the service life is about 10 years.

1. Turn ON the control power supply of SERVOPACK and wait at least 30 minutes after SENS_ON command is transmitted until the capacitor inside the encoder is charged.
2. Replace the battery. The SERVOPACK power supply may be ON or OFF when the battery is replaced.

Encoder multiturn data will not be lost if the battery is replaced using the instructions given above.

IMPORTANT

When replacing the battery with the multiturn data remaining, leave the encoder power supply for at least 30 minutes (SENS_ON command transfer).

12.2 Troubleshooting

12.2.1 Servomotors

See *Table 12.5* for the appropriate action when a problem occurs during operation, and be sure to turn OFF the servo system power supply before commencing the procedures that are shaded. Contact your Yaskawa representative immediately if the problem cannot be resolved using the described procedures.

Table 12.5 Causes, Inspection Areas, and Remedies

Symptom	Cause	Inspection	Remedy
Servomotor does not run	Overloaded	Try running with no load	Reduce the load or replace with a larger capacity Servomotor.
	Loose connection	Check connector terminals	Tighten any loose parts.
	External connector wiring incorrect	Check external connector wiring	Refer to the connection diagram and correct the wiring.
Unstable Servomotor rotation	Faulty connection	Check the Phase-U, -V and -W lead terminals as well as feedback pulse connection.	Reconnect the wiring.
Servomotor overheated	Ambient temperature too high	Check to see if the ambient temperature is below 40°C.	Reduce the ambient temperature to below 40°C.
	Servomotor surface dirty	Check visually.	Clean dust and oil from the motor surface.
	Overloaded	Try operating with no load	Reduce the load or replace with a larger capacity Servomotor.
Abnormal noise	Mechanical mounting incorrect	<ul style="list-style-type: none"> • Loose Servomotor mounting screws? • Coupling not centered? • Coupling unbalanced? 	<ul style="list-style-type: none"> • Tighten mounting screws. • Center or balance the coupling.
	Bearing defective	Check for noise and vibration near the bearing.	Contact your Yaskawa representative if defective.
	Vibration caused by the equipment	Foreign objects, damage, or deformation of sliding parts.	Contact the equipment manufacturer.

Note Be sure to turn OFF the power supply when performing the inspection or remedy in the shaded boxes.

12.2.2 SERVOPACKS

■ Troubleshooting Using MECHATROLINK Communication Data

Table 12.6 shows examples of troubleshooting problems with MECHATROLINK communication data (alarm code).

Table 12.6 Troubleshooting with MECHATROLINK Communication Data

Alarm Code (Alarm/warning History)	Status When Lit	Cause	Remedy
"10" Overcurrent	Lit at power ON	Circuit board (1PWB) defective	Replace SERVOPACK.
	Lit at power ON and servo ON	Current feedback circuit or power transistor defective. Dynamic brake circuit defective.	Replace SERVOPACK.
"11" Ground	At main circuit power supply ON	Servomotor or wiring grounded.	Replace the Servomotor and correct Servomotor wiring.
		Main circuit grounded.	Replace SERVOPACK.
"40" Overvoltage	Lit with normal running or deceleration	GD ² load too large.	Check the load inertia for the moment of inertia on the motor shaft.
		Circuit board (1PWB) defective.	Replace SERVOPACK.
"41" Insufficient Voltage	During Servomotor driving	Power supply voltage not within specifications.	Check the power supply.
		Rectifier diode malfunctioned. Fuse blown. Rush current limit resistor blown. Circuit board (1PWB) defective.	Replace SERVOPACK.
"51" Overspeed	Lit with high-speed Servomotor rotation after reference input	Servomotor wiring incorrect. Encoder wiring incorrect.	<ul style="list-style-type: none"> • Check and correct wiring. • Check to see if the Phase-A, -B and -C pulses are correct at 2CN, and repair (disconnection, short, no power supply, defective circuit board) if necessary.

Alarm Code (Alarm/warning History)	Status When Lit	Cause	Remedy
"D0" Overflow	No feedback pulse after moving reference input	Servomotor wiring incorrect. Encoder wiring incorrect.	<ul style="list-style-type: none"> Check and correct Servomotor wiring. Check to see if the Phase-A, -B and -C pulses are correct at 2CN, and repair (disconnection, short, no power supply, defective circuit board.) if necessary.
		Control board (1PWB) defective.	Replace SERVOPACK.
	Overflow during high-speed running	Servomotor wiring incorrect. Encoder wiring incorrect.	<ul style="list-style-type: none"> Check and correct Servomotor wiring. Check to see if the Phase-A, -B and -C pulses are correct at 2CN, and repair (disconnection, short, no power supply, defective circuit board.) if necessary.
		User constant setting incorrect.	Set the correct user constant.
		Control board (1PWB) defective.	Replace SERVOPACK.
	Normal running by overflow with large move reference input	SERVOPACK adjustment incorrect.	Increase speed loop gain (Cn-0004).
		Load capacity too large.	Review the load. (overload or load inertia)
Feed speed too large.		Decrease the feed speed.	
"71" Instantaneous overload	Lit during driving Operation resumes after turning power OFF and ON.	Load greatly exceeds the rated torque from several seconds to tens second.	Review the load. (overload)
"72" Continuous overload	Lit during operation Operation resumes after turning power OFF and ON.	Load greatly exceeds the rated torque from ten seconds to hundreds second.	Review the load. (overload)
"80" Absolute encoder error (only if an absolute encoder is used)	At control power supply ON	Faulty absolute encoder wiring (PA, PB, PC).	Check absolute encoder connections.
		Absolute encoder malfunction.	Send the SENS_OFF command and resend the SENS_ON command.
		Control board (1PWB) defective.	Replace SERVOPACK.
	During Servomotor driving	Absolute encoder error occurred.	Send the SENS_OFF command and resend the SENS_ON command.
		SERVOPACK miscounted pulses (incorrect position) or malfunctioned due to noise.	Separate encoder wiring from main circuits, transfer the SENS_OFF command (servo OFF if driving) and resend the SENS_ON command.
		Number of encoder pulses set incorrectly.	Reset the correct number of encoder pulses.

Alarm Code (Alarm/warning History)	Status When Lit	Cause	Remedy
"81" Absolute encoder backup error (only if a 12-bit absolute encoder is used)	At the SENS_ON command transfer	The following power supplied to the absolute encoder all failed: <ul style="list-style-type: none"> • +5 V power supply • Battery • Internal capacitor 	Follow the absolute encoder set-up procedure.
		Control board (1PWB) defective.	Replace SERVOPACK.
"82" Absolute encoder checksum error (only if a 12-bit absolute encoder is used)	During Servomotor driving or the SENS_ON command transferring	Absolute encoder memory check error occurred.	Follow the absolute encoder set-up procedure.
		Control board (1PWB) defective.	Replace SERVOPACK.
"83" Absolute encoder battery error (only if an absolute encoder is used)	At control power supply ON or the SENS_ON command transfer (only if a 12-bit encoder is used)	Battery not connected. Battery connection defective. Battery voltage is lower than about 3.3 V.	Check and correct battery connections. Replace with a new battery.
		Control board (1PWB) defective	Replace SERVOPACK.
"84" Absolute encoder data error (only if a 12-bit absolute encoder is used)	At the SENS_ON command transfer	Absolute encoder malfunctioned.	Transfer the SENS_OFF command and resend the SENS_ON command.
		Control board (1PWB) defective.	Replace SERVOPACK.
"85" Absolute encoder overspeed (only if a 12-bit absolute encoder is used)	At the SENS_ON command transfer	Absolute encoder turned ON at the motor speed exceeding 400 r/min.	Transfer the SENS_ON command at a speed lower than 400 r/min.
		Control board (1PWB) defective.	Replace SERVOPACK.
"C1" Servo overrun	Lit soon after Servomotor started to run	Servomotor wiring incorrect or disconnected.	Check wiring and connectors at the Servomotor.
		Encoder wiring incorrect or disconnected.	Check wiring and connectors at the encoder.
"C2" Phase error detection	Lit in 1 to 3 seconds after power ON.	Faulty encoder wiring or connection.	Check wiring and connectors at the encoder.
		Noise in encoder wiring.	Separate encoder wiring from main wiring circuits.
		Encoder defective.	Replace Servomotor.
	Lit during driving	Faulty encoder wiring or connection.	Check wiring and connectors at the encoder.
		Noise in encoder wiring.	Separate encoder wiring from main wiring circuits.
		Encoder defective.	Replace Servomotor.
"C3" Encoder Phase PA, PB Broken wire	Lit soon after Servomotor started to run	Faulty encoder wiring (PA, PB) or connection.	Check wiring and connectors at the encoder.
"C4" Encoder Phase PC Broken wire	Lit soon after Servomotor started to run	Faulty encoder wiring (PC) or connection.	Check wiring and connectors at the encoder.

Alarm Code (Alarm/warning History)	Status When Lit	Cause	Remedy
“C5” Initial pulse error	At the SENS-ON or CONFIG command transfer	Incorrect encoder type setting	Reset the encoder type
		Faulty encoder	Replace the encoder.
		Faulty control board (1PWB)	Replace the SERVOPACK.
“00” Absolute encoder data error	Lit in several seconds after power ON	• Absolute encoder malfunctioned.	Turn power back ON. Follow the absolute encoder setup procedures.
		• Absolute encoder wiring incorrect.	Check and correct absolute encoder wiring.
“02” Broken user constant	Lit at power ON	Circuit board (1PWB) defective.	Replace SERVOPACK.
“05” Alarm history overflow	Lit at power ON	Alarm or warning occurs continuously.	Remove the cause of alarm or warning, then turn the power ON again.
“94” User constant setting warning	Lit at power ON	An user constant was set out of range via MECHATROLINK communication or the setting order was incorrect.	Set the correct setting and review the exact setting order.
“95” Command warning	At command transfer	The CONNECT command has not been transferred.	Transfer the CONNECT command.
	At the SV-ON command transfer	The CONNECT or SENS-ON command has not been transferred.	Transfer the CONNECT or SENS-ON command.
		Main power supply not turn ON.	Turn ON the main power supply. (Check the sequence.)
At the synchronous command (SYNC_SET) transfer	Communication phase 3 has not been reached.	Establish a sync by CONNECT command (normal, synchronum) or the SYNC-SET command.	
“7A” Heat sink overheated	Lit during operation	SERVOPACK ambient temperature exceeds 55°C.	Reduce SERVOPACK ambient temperature to under 55°C.
		Poor heat sink air circulation.	Follow the mounting procedures and stipulation for surrounding space.
		Fan stopped.	Replace SERVOPACK.
		Driving above the rated load.	Reduce the load.
	At control power supply turn ON	Control board (1PWB) defective.	Replace SERVOPACK.
“E5” Synchronization error	At command transfer	WDT data does not match.	Update the WDT data at each communication cycle.
“96”, “E6” Communications error	At control power supply turn ON	Faulty contact between cable and connector .	Correct the connector wiring.
		Malfunction due to noise	Take action to eliminate noise.

Alarm Code (Alarm/warning History)	Status When Lit	Cause	Remedy
"B□" Hardware error	At control power supply turn ON	Control board (1PWB) defective.	Replace SERVOPACK.
	At main circuit power supply turn ON	Rectifier diode malfunctioned. Fuse blown.	
		Rush current limit resistor blown. Regenerative transistor malfunctioned.	
At main circuit power supply turn OFF	Regenerative transistor and regenerative resistor malfunctioned. Control board (1PWB) defective.		
"F1" Power supply line not connected	At main circuit power supply turn ON	One phase (R, S, or T) of the main circuit power is not connected to the power supply.	Check the power supply. Check main circuit power supply wiring. MCCB or noise filter Check the electromagnetic contactor.
		Line voltage of one of the phases is low.	Check the power supply.
		SERVOPACK defective.	Replace SERVOPACK.

Note The alarm code "00" is reset by turning OFF the encoder power supply (by transferring SENS_OFF command) or by transferring ALM_CLR command

■ Problems due to Defective Wiring or Parts

Table 12.7 Problems due to Defective Wiring or Parts

Symptom	Check Areas and Items	Remedy
Motor will not run with reference input	Check voltage between R, S and T. Make sure the alarm indicator is not lit. Check the N-OT and P-OT signals. Check SERVOPACK status using the status monitor command SMON.	Check the AC power supply circuit. Look for a cause if an indicator is lit.

■ Problems due to Setting Errors

Table 12.8 Problems due to Setting Errors

Symptom	Cause	Remedy
Poor servo tracking performance	Position loop gain too low	Increase the position loop gain (Cn-001A). Decrease the speed loop gain when increasing position loop gain causes hunting. Note Do not increase the position loop gain any higher once hunting occurs. This is the tracking performance limit.

■ Troubleshooting: No Alarm and Warning Displayed but Motor Does Not Run

Table 12.9 Troubleshooting with no Alarm Displays

Symptom	Cause	Conditions	Remedy
Servomotor does not run	Main power supply not turn ON	Check voltage across the power supply terminals.	Correct the power supply circuit.
	Loose connection	Check 1CN and 2CN connectors and terminals.	Tighten any loose parts.
	1CN connector external wiring incorrect	Check 1CN connector external wiring.	Refer to the connection diagram and correct the wiring.
	Encoder to Servomotor wiring disconnected	–	Reconnect the wiring.
	Overloaded	Run under no-load conditions.	Reduce the load or replace with a larger capacity Servomotor.
	Move reference not transferred	Check by MECHATROLINK communications or MECHATROLINK monitoring.	Transfer the moving reference.
	SV_ON command not transferred		Transfer the SV_ON command.
	SENS_ON command not transferred		Transfer the SENS_ON command.
	Encoder type differs from the user constant setting	Check whether the encoder is an incremental or absolute encoder.	Set user constant Cn-0001 bit 14 according to the encoder type.
	P-OT and N-OT inputs are turned OFF	If Cn-0001 bits 2 and 3 are 0	Turn ON the P-OT and N-OT inputs.
Servomotor moves instantaneously, then stops	Number of encoder pulses differs from the user constant setting	–	Set user constant Cn-0011 according to the number of encoder pulses.
	Servomotor or encoder wiring incorrect	–	Correct the wiring.
Servomotor speed unstable	Wiring connection to the Servomotor defective	Check power lead (U-, V- and W-phases) and encoder connector connections.	Tighten any loose terminals or connectors.
Servomotor vibrates around 200 to 400 Hz	Speed loop gain value too high	–	Reduce the speed loop gain user constant Cn-0004.
High rotation speed overshoot on starting and stopping	Speed loop gain value too high	–	Reduce the speed loop gain user constant Cn-0004.
Servomotor overheated	Ambient temperature too high	Measure the Servomotor ambient temperature.	Reduce Servomotor ambient temperature to under 40°C.
	Servomotor surface dirty	Check visually.	Clean off dust and oil from the Servomotor surface.
	Overloaded	Run under no-load conditions.	Reduce the load or replace with a larger capacity Servomotor.

Symptom	Cause	Conditions	Remedy
Abnormal noise	Mechanical mounting incorrect	Check whether Servomotor mounting screws are loose.	Tighten the mounting screws.
		Check whether coupling is misaligned.	Align the coupling.
		Check whether the coupling is unbalanced.	Balance the coupling.
	Bearing defective	Check noise and vibration near the bearing.	Contact your Yaskawa representative.
	Equipment causing vibrations	Check the movable parts for foreign matter, damage or deformation.	Consult with the equipment manufacturer.

Σ Series SGM□/SGDB USER'S MANUAL

IRUMA BUSINESS CENTER

480, Kamifujisawa, Iruma, Saitama 358-8555, Japan
Phone 81-4-2962-5696 Fax 81-4-2962-6138

YASKAWA ELECTRIC AMERICA, INC.

2121 Norman Drive South, Waukegan, IL 60085, U.S.A.
Phone 1-847-887-7000 Fax 1-847-887-7370

MOTOMAN INC. HEADQUARTERS

805 Liberty Lane West Carrollton, OH 45449, U.S.A.
Phone 1-937-847-6200 Fax 1-937-847-6277

YASKAWA ELÉTRICO DO BRASIL COMÉRCIO LTD.A.

Avenida Fagundes Filho, 620 Bairro Saude-Sao Paulo-SP, Brazil CEP: 04304-000
Phone 55-11-5071-2552 Fax 55-11-5581-8795

YASKAWA ELECTRIC EUROPE GmbH

Am Kronberger Hang 2, 65824 Schwalbach, Germany
Phone 49-6196-569-300 Fax 49-6196-569-312

Motoman Robotics Europe AB

Box 504 S38525 Torsås, Sweden
Phone 46-486-48800 Fax 46-486-41410

Motoman Robotec GmbH

Kammerfeldstraße 1, 85391 Allershausen, Germany
Phone 49-8166-90-100 Fax 49-8166-90-103

YASKAWA ELECTRIC UK LTD.

1 Hunt Hill Orchardton Woods Cumbernauld, G68 9LF, United Kingdom
Phone 44-1236-735000 Fax 44-1236-458182

YASKAWA ELECTRIC KOREA CORPORATION

Kipa Bldg #1201, 35-4 Youido-dong, Yeongdungpo-Ku, Seoul 150-010, Korea
Phone 82-2-784-7844 Fax 82-2-784-8495

YASKAWA ELECTRIC (SINGAPORE) PTE. LTD.

151 Lorong Chuan, #04-01, New Tech Park Singapore 556741, Singapore
Phone 65-6282-3003 Fax 65-6289-3003

YASKAWA ELECTRIC (SHANGHAI) CO., LTD.

No.18 Xizang Zhong Road. Room 1805, Harbour Ring Plaza Shanghai 20000, China
Phone 86-21-5385-2200 Fax 86-21-5385-3299

YATEC ENGINEERING CORPORATION

4F., No.49 Wu Kong 6 Rd, Wu-Ku Industrial Park, Taipei, Taiwan
Phone 886-2-2298-3676 Fax 886-2-2298-3677

YASKAWA ELECTRIC (HK) COMPANY LIMITED

Rm. 2909-10, Hong Kong Plaza, 186-191 Connaught Road West, Hong Kong
Phone 852-2803-2385 Fax 852-2547-5773

BEIJING OFFICE

Room No. 301 Office Building of Beijing International Club, 21
Jianguomenwai Avenue, Beijing 100020, China
Phone 86-10-6532-1850 Fax 86-10-6532-1851

TAIPEI OFFICE

9F, 16, Nanking E. Rd., Sec. 3, Taipei, Taiwan
Phone 886-2-2502-5003 Fax 886-2-2505-1280

SHANGHAI YASKAWA-TONGJI M & E CO., LTD.

27 Hui He Road Shanghai China 200437
Phone 86-21-6553-6060 Fax 86-21-5588-1190

BEIJING YASKAWA BEIKE AUTOMATION ENGINEERING CO., LTD.

30 Xue Yuan Road, Haidian, Beijing P.R. China Post Code: 100083
Phone 86-10-6233-2782 Fax 86-10-6232-1536

SHOUGANG MOTOMAN ROBOT CO., LTD.

7, Yongchang-North Street, Beijing Economic Technological Investment & Development Area,
Beijing 100076, P.R. China
Phone 86-10-6788-0551 Fax 86-10-6788-2878



YASKAWA ELECTRIC CORPORATION

YASKAWA

In the event that the end user of this product is to be the military and said product is to be employed in any weapons systems or the manufacture thereof, the export will fall under the relevant regulations as stipulated in the Foreign Exchange and Foreign Trade Regulations. Therefore, be sure to follow all procedures and submit all relevant documentation according to any and all rules, regulations and laws that may apply.

Specifications are subject to change without notice for ongoing product modifications and improvements.

© 1998-2004 YASKAWA ELECTRIC CORPORATION. All rights reserved.

MANUAL NO. SIE-S800-26.4C

Printed in Japan January 2004 98-3

04-1⑤ 94-C23-065L