

› **Handbook of Timing Belts, Pulleys, Chains and Sprockets**

The Technical Section of this catalog is the result of close cooperation of Stock Drive Products / Sterling Instrument staff with experts in the fields of power transmission design and manufacturing. We wish, therefore, to recognize the contribution of the following company and individuals:



**The Gates Rubber Company**, that provided the material contained in their publication 17183.

Staff of **Stock Drive Products / Sterling Instrument**.

No part of this publication may be reproduced in any form or by any means without the prior written permission of the Company. This does not cover material which was attributed to another publication.

TABLE OF CONTENTS	PAGE
<b>SECTION 1 INTRODUCTION</b> .....	T-3
<b>SECTION 2 GATES POWERGRIP® GT® 3 BELT DRIVES</b> .....	T-4
<b>SECTION 3 COMPARISON GRAPHS</b> .....	T-6
<b>SECTION 4 DRIVE COMPARATIVE STUDIES</b> .....	T-8
4.1 Durability .....	T-8
4.2 Tooth Jump Resistance .....	T-8
4.3 Noise .....	T-9
4.4 Positioning Accuracy .....	T-9
<b>SECTION 5 DIFFERENT BELT CONFIGURATIONS</b> .....	T-10
5.1 Double-Sided Twin Power® Belt Drives .....	T-10
5.2 Long Length Timing Belt Stock .....	T-10
<b>SECTION 6 BELT CONSTRUCTION</b> .....	T-10
6.1 Characteristics Of Reinforcing Fibers .....	T-11
6.2 Cord Twist And Its Effect On The Drive .....	T-12
6.3 Factors Contributing To Side Travel .....	T-13
6.4 Characteristics Of Belt Body Materials .....	T-14
<b>SECTION 7 BELT TOOTH PROFILES</b> .....	T-15
<b>SECTION 8 PULLEY PITCH AND OUTSIDE DIAMETERS</b> .....	T-16
<b>SECTION 9 DESIGN AND INSTALLATION SUGGESTIONS</b> .....	T-22
9.1 Low-Speed Operation .....	T-23
9.2 High-Speed Operation .....	T-23
9.3 Smooth Running .....	T-24
9.4 Drive Noise .....	T-24
9.5 Static Conductivity .....	T-24
9.6 Operating Environments .....	T-25
9.7 Belt Tracking .....	T-26
9.8 Pulley Flanging .....	T-27
9.9 Registration .....	T-28
<b>SECTION 10 BELT TENSIONING</b> .....	T-29
10.1 What Is Proper Installation Tension .....	T-29
10.2 Making Measurements .....	T-31
<b>SECTION 11 DRIVE ALIGNMENT</b> .....	T-32
11.1 Angular And Parallel .....	T-32
11.2 Practical Tips .....	T-33
<b>SECTION 12 INSTALLATION AND TAKE-UP</b> .....	T-33
12.1 Installation Allowance .....	T-33

# TIMING BELTS, PULLEYS, CHAINS AND SPROCKETS

I

R

T

12.2	Belt Installation .....	T-33
12.3	Belt Take-up .....	T-34
12.4	Fixed Center Drives .....	T-34

## SECTION 13 IDLER USAGE .....

T-35

13.1	Inside/Outside .....	T-35
13.2	Tight Side/Slack Side .....	T-35
13.3	Idler Placement .....	T-35
13.4	Spring-Loaded Idlers .....	T-35
13.5	Size Recommendations .....	T-35
13.6	Specifying Shaft Locations In Multipoint Drive Layouts .....	T-36

## SECTION 14 BELT PULL AND BEARING LOADS .....

T-37

14.1	Motion Transfer Drives .....	T-38
14.2	Power Transmission Drives .....	T-38
14.3	Registration Drives .....	T-39
14.4	Bearing Load Calculations .....	T-39

## SECTION 15 HANDLING AND STORAGE .....

T-40

## SECTION 16 STANDARDS APPLICABLE TO BELTS .....

T-40

## SECTION 17 STANDARDS APPLICABLE TO PULLEYS AND FLANGES .....

T-42

17.1	Pulley Tolerances .....	T-43
17.2	Pulley Materials .....	T-46
17.3	Flange Design And Face Width Guidelines .....	T-46
17.4	Guidelines For PowerGrip® GT®3 Flange Design .....	T-47

## SECTION 18 DOUBLE-SIDED TWIN POWER® BELT TOLERANCES .....

T-48

## SECTION 19 LONG LENGTH TIMING BELT STOCK SPECIFICATIONS .....

T-49

## SECTION 20 DESIGN AIDS ON INTERNET () .....

T-50

## SECTION 21 DRIVE RATIO TABLES .....

T-51

## SECTION 22 CENTER DISTANCE FORMULAS .....

T-58

22.1	Nomenclature And Basic Equations .....	T-58
22.2	Exact Center Distance Determination – Unequal Pulleys .....	T-58
22.3	Exact Center Distance Determination – Equal Pulleys .....	T-59
22.4	Approximate Center Distance Determination .....	T-59
22.5	Number Of Teeth In Mesh (TIM) .....	T-59
22.6	Determination Of Belt Size For Given Pulleys And Center Distance .....	T-60

## SECTION 23 CENTER DISTANCE FACTOR TABLES .....

T-60

## SECTION 24 TIMING BELT DRIVE SELECTION PROCEDURE .....

T-61

## LIST OF TABLES .....

T-83

## LIST OF FIGURES .....

T-85

1

2

3

4

5

6

7

8

9

10

11

12

13

14

15

A

## SECTION 1 INTRODUCTION

Timing belts are parts of synchronous drives which represent an important category of drives. Characteristically, these drives employ the positive engagement of two sets of meshing teeth. Hence, they do not slip and there is no relative motion between the two elements in mesh.

Due to this feature, different parts of the drive will maintain a constant speed ratio or even a permanent relative position. This is extremely important in applications such as automatic machinery in which a definite motion sequence and/or indexing is involved.

The positive nature of these drives makes them capable of transmitting large torques and withstanding large accelerations.

Belt drives are particularly useful in applications where layout flexibility is important. They enable the designer to place components in more advantageous locations at larger distances without paying a price penalty. Motors, which are usually the largest heat source, can be placed away from the rest of the mechanism. Achieving this with a gear train would represent an expensive solution.

Timing belts are basically flat belts with a series of evenly spaced teeth on the inside circumference, thereby combining the advantages of the flat belt with the positive grip features of chains and gears.

There is no slippage or creep as with plain flat belts. Required belt tension is low, therefore producing very small bearing loads. Synchronous belts will not stretch and do not require lubrication. Speed is transmitted uniformly because there is no chordal rise and fall of the pitch line as in the case of roller chains.

The tooth profile of most commonly known synchronous belts is of trapezoidal shape with sides being straight lines which generate an involute, similar to that of a spur gear tooth. As a result, the profile of the pulley teeth is involute. Unlike the spur gear, however, the outside diameter of a timing pulley is smaller than its pitch diameter, thus creating an imaginary pitch diameter which is larger than the pulley itself. This is illustrated in **Figure 1**. Backlash between pulley and belt teeth is negligible.

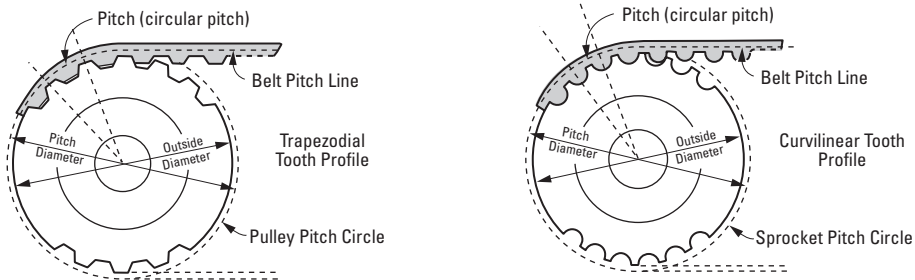
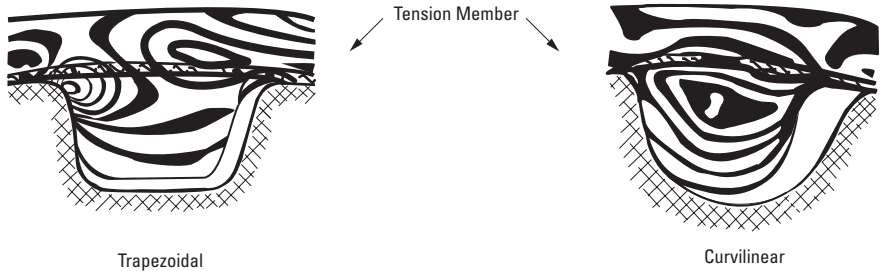

**Fig. 1 Pulley and Belt Geometry**

The trapezoidal shape timing belt was superseded by a curvilinear tooth profile which exhibited some desirable and superior qualities. Advantages of this type of drive are as follows:

- Proportionally deeper tooth; hence tooth jumping or loss of relative position is less probable.
- Lighter construction, with correspondingly smaller centrifugal loss.
- Smaller unit pressure on the tooth since area of contact is larger.
- Greater shear strength due to larger tooth cross section.
- Lower cost since a narrower belt will handle larger load.
- Energy efficient, particularly if replacing a "V" belt drive which incurs energy losses due to slippage.
- Installation tension is small, therefore, light bearing loads.

**NOTE:** Credit for portions of this technical section are given to: Gates Rubber Co., Sales Engineering Dept., Rubber Manufacturers Association (RMA), International Organization for Standardization (ISO).



**Fig. 2 Stress Pattern in Belts**

In **Figure 2**, the photoelastic pattern shows the stress distribution within teeth of different geometry. There is a definite stress concentration near the root of the trapezoidal belt tooth, with very low strains elsewhere. For the curvilinear tooth, there is a uniform, nearly constant, strain distribution across the belt. The load is largest in the direction of the tension member to which it is transferred.

Because of their superior load carrying capabilities, the curvilinear belts are marketed under the name of Gates' HTD drives. This is an abbreviation of High Torque Drives.

As a result of continuous research, a newer version of the curvilinear technology was developed by Gates, which was designated as Gates' PowerGrip® GT®3 belt drives.

**SECTION 2 GATES POWERGRIP® GT®3 BELT DRIVES**

The PowerGrip GT3 Belt Drive System is an advance in product design over the Gates' older, standard HTD system. The PowerGrip GT3 System, featuring a modified curvilinear belt tooth profile, provides timing and indexing accuracy superior to the conventional PowerGrip Trapezoidal Belt System. Plus, PowerGrip GT3 Belts have a higher capacity and longer belt life than trapezoidal belts.

It's difficult to make a true quantitative comparison between the backlash of a trapezoidal tooth drive and PowerGrip GT3 drive due to the difference in "pulley to belt tooth" fit (see **Figure 3**). Trapezoidal belts contact the pulley in the root radius-upper flank area only, while the PowerGrip GT3 system permits full flank contact.

The main stress line in a trapezoidal tooth timing belt is at the base of the teeth. During operation, this stress greatly reduces belt life. The PowerGrip GT3 system overcomes this condition with its complete tooth flank contact which eliminates the tooth stress line area. This greatly increases belt life and prevents tooth distortion caused by drive torque. In addition, the conventional timing belt has a chordal effect as it wraps small pulleys. This is significantly reduced in the PowerGrip GT3 system because there is full tooth support



**Fig. 3 Comparison of Different Tooth Profiles**

along the pulley. Full support improves meshing, reduces vibration and minimizes tooth deformation.

On drives using a low installation tension, small pulleys, and light loads, the backlash of the PowerGrip GT3 system will be slightly better than the trapezoidal timing belt system. However, with increased tension and/or loads and/or pulley sizes, the performance of the PowerGrip GT3 system becomes significantly better than the trapezoidal timing belt system.

The PowerGrip GT3 system is an extension of the HTD system with greater load-carrying capacity. HTD was developed for high torque drive applications, but is not acceptable for most precision indexing or registration applications. The HTD design requires substantial belt tooth to pulley groove clearance (backlash) to perform.

As smaller diameter pulleys are used, the clearance required to operate properly is increased. HTD drive clearance, using small diameter pulleys, is approximately four times greater than an equivalent GT3 timing belt drive.

The PowerGrip GT3 system's deep tooth design increases the contact area which provides improved resistance to ratcheting. The modified curvilinear teeth enter and exit the pulley grooves cleanly, resulting in reduced vibration. This tooth profile design results in parallel contact with the groove and eliminates stress concentrations and tooth deformation under load. The PowerGrip GT3 design improves registration characteristics and maintains high torque carrying capacity.

PowerGrip GT3 belts are currently available in 2 mm, 3 mm, 5 mm, 8 mm and 14 mm pitches. Specific advantages of the PowerGrip GT3 system can be summarized as follows:

- **Longer belt life**

The strong fiberglass tensile cords wrapped in a durable neoprene body provide the flexibility needed for increased service life. The deep tooth profile provides superior load-carrying strength and greatly reduces ratcheting when used with pulleys provided by a licensed supplier.

- **Precision registration**

PowerGrip GT3 belts provide timing and synchronization accuracy that make for flawless registration, with no loss of torque carrying capacity.

- **Increased load-carrying capacity**

Load capacities far exceed HTD and trapezoidal belt capabilities making PowerGrip GT3 belts the choice for accurate registration, heavy loads and small pulleys.

- **Quieter operation**

The PowerGrip GT3 belt's specially engineered teeth mesh cleanly with pulley grooves to reduce noise and vibration. Clean meshing and reduced belt width result in significant noise reduction when compared to Trapezoidal and HTD belts.

- **Precise positioning**

PowerGrip GT3 belts are specifically designed for applications where precision is critical, such as computer printers and plotters, laboratory equipment and machine tools.

Some of the many applications of PowerGrip GT3 belts are:

- |                                 |                                |                      |
|---------------------------------|--------------------------------|----------------------|
| • data storage equipment        | • printers                     | • ticket dispensers  |
| • machine tools                 | • floor care equipment         | • plotters           |
| • hand power tools              | • money handling equipment     | • copiers            |
| • postage handling equipment    | • medical diagnostic equipment | • robotics equipment |
| • DC stepper/servo applications | • sewing machines              | • vending equipment  |
| • food processors               | • vacuum cleaners              | • office equipment   |
| • centrifuges                   | • automated teller machines    |                      |

R SECTION 3 COMPARISON GRAPHS

T In order to provide comparison of performances of different pitch drives, several graphs have been developed. **Figure 4** shows numerical values, plotted in logarithmic scale, of Rated Horsepower vs. Speed (rpm) of faster shaft.

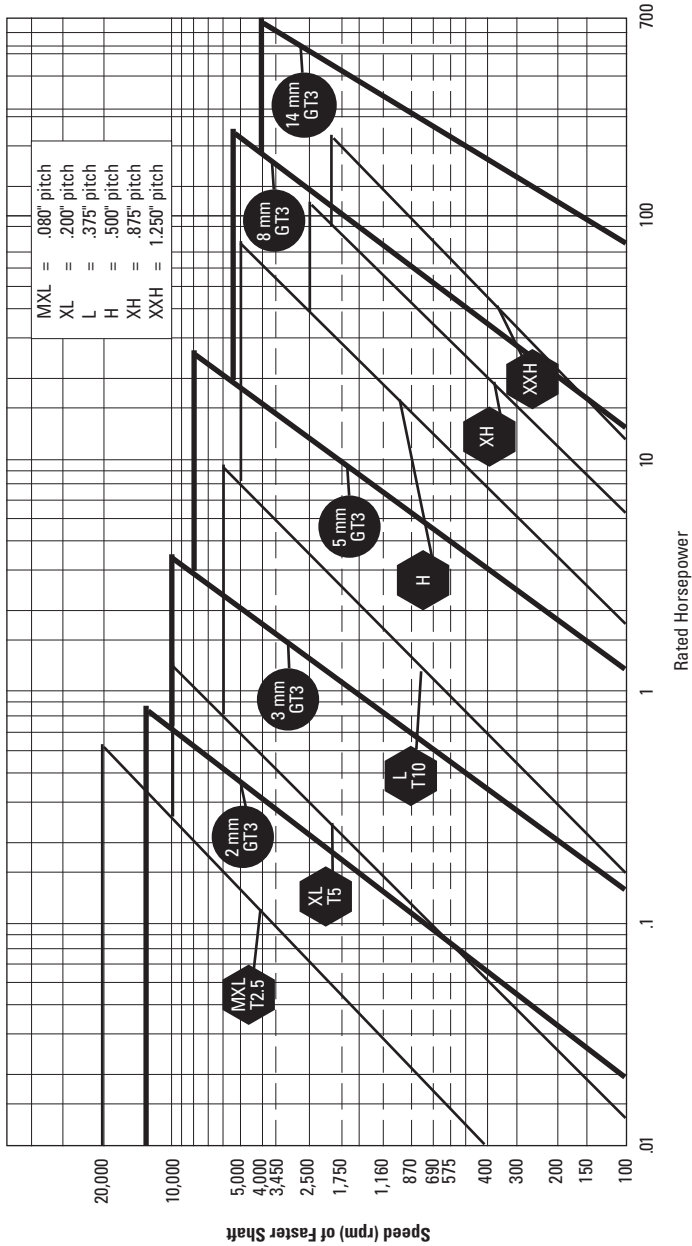
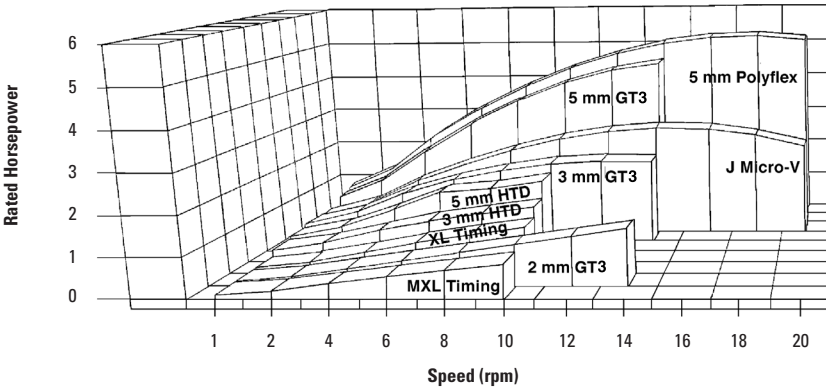

Fig. 4 Comparative Belt Pitch Selection Guide

**Figure 5** shows an illustrative graph representation of horsepower ratings over a wide speed range of the belt types commonly used. The graph assumes that belt widths and pulley diameters have been chosen such that they provide realistic comparison of product capability.



**Fig. 5 Horsepower Ratings at High Speed**

**Figure 6** provides a comparison of the rated torque carrying capabilities of synchronous belts, on small diameter pulleys at low speeds. The pulley diameters and belt widths represent a realistic comparison.

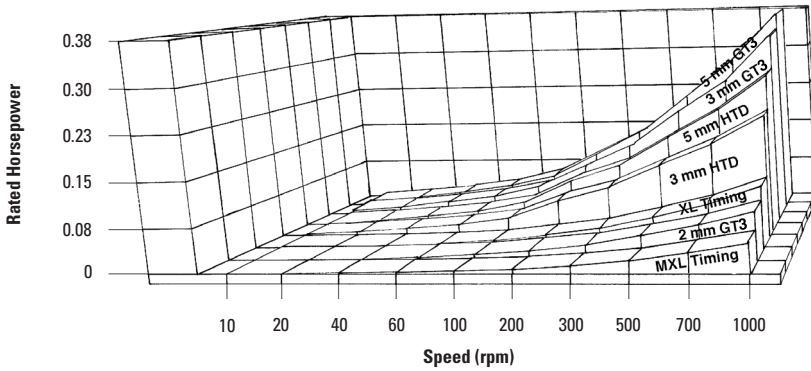

**Fig. 6 Horsepower Ratings at Low Speed**

## SECTION 4 DRIVE COMPARATIVE STUDIES

The development of the PowerGrip GT3 belt has produced an impressive range of enhanced properties and subsequent design opportunities for engineers.

Comparative studies, shown in **Figures 7** through **10**, allow designers to make quantitative assessments and to highlight the most significant improvements and design opportunities. Particularly significant points from the comparative studies follow:

### 4.1 Durability

The greatly increased durability of the PowerGrip GT3 design has resulted in power capacities far above those quoted for similar size belts of previous designs. The resulting small drive packages will increase design flexibility, space utilization and cost effectiveness.

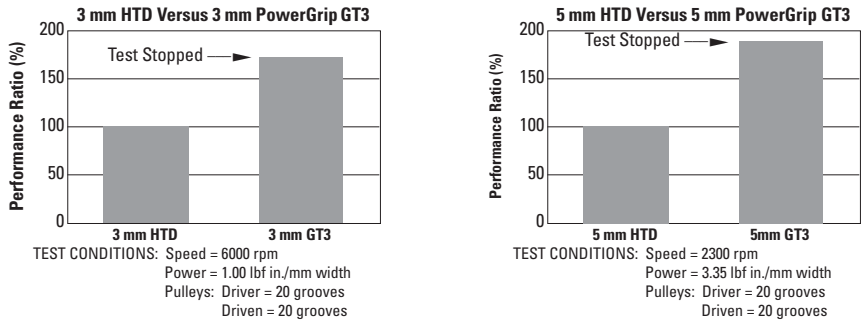
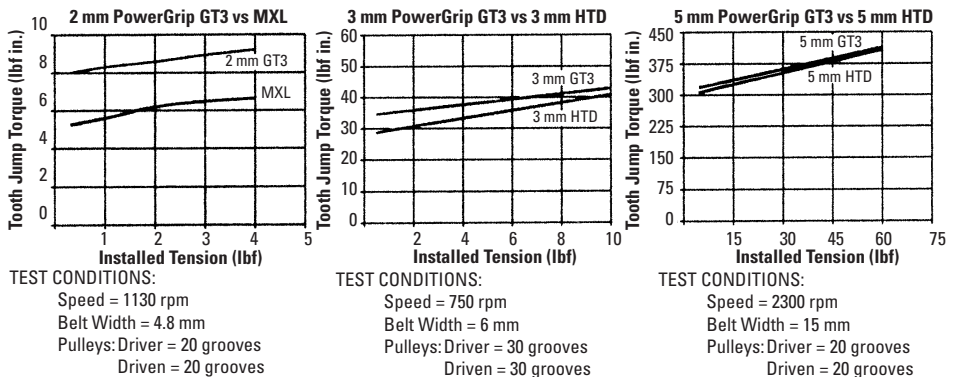

**Fig. 7 Comparison of Performance Ratios for Various Belts**

### 4.2 Tooth Jump Resistance

The very significant improvement in tooth jump resistance of PowerGrip GT3 when compared to similar belts has several important advantages.

1. Ratcheting resistance during high start-up torques.
2. Reduced bearing loads, particularly in fixed-center drives. Lower average tensions can be used without encountering tooth jump at the low tension end of the tolerance ranges.
3. Reduced system losses result from lower pre-tensioning, with less potential for tooth jumping.



**Fig. 8 Comparison of Tooth Jump Torques for Various Belts**

**4.3 Noise**

The smoother meshing action of the PowerGrip GT3 belt, with its optimized design, produces significantly lower noise levels when compared with other similar sized belt types operating under similar speeds and tensions. These improvements are enhanced by the fact that narrower belts can be used due to increased power capacities.

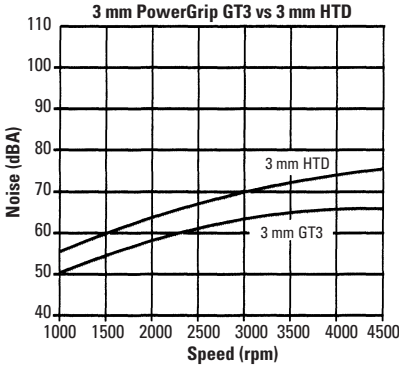

Belt: No. of teeth = 188  
Width = 15 mm  
Pulleys: Driver = 26 grooves  
Driven = 26 grooves  
Microphone location midway between the pulleys, 100 mm from the belt edge.

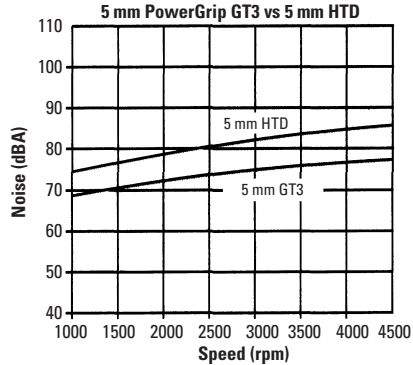

Belt: No. of teeth = 118  
Width = 30 mm  
Pulleys: Driver = 20 grooves  
Driven = 20 grooves  
Microphone location midway between the pulleys, 100 mm from the belt edge.

**Fig. 9 Comparison of Noise Levels for Various Belts**

**4.4 Positioning Accuracy**

The PowerGrip HTD belt tooth forms were primarily designed to transmit high torque loads. This requirement increased tooth to groove clearances which resulted in increased backlash when compared with the original trapezoidal designs.

PowerGrip GT3 has reversed this problem with power capacities now exceeding those of PowerGrip HTD while giving equivalent or higher levels of positional accuracy than trapezoidal timing belts.

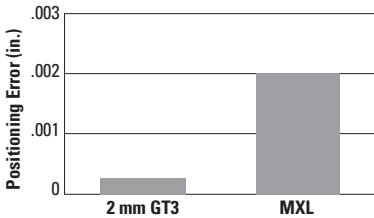

APPLICATION: Motion Transfer  
Belt: No. of teeth = 126  
Width = 8 mm  
Pulleys: Driver = 12 grooves  
Driven = 40 grooves  
Installed tension = 1.8 lbf  
Motor = 200 steps/cycle

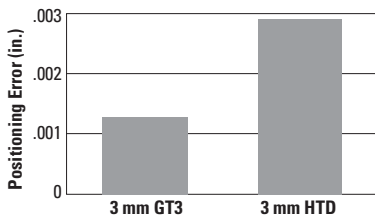

APPLICATION: Motion Transfer  
Belt: No. of teeth = 92  
Width = 6 mm  
Pulleys: Driver = 20 grooves  
Driven = 20 grooves  
Installed tension = 6.6 lbf  
Motor = 200 steps/cycle

**Fig. 10 Comparison of Positioning Errors of Various Belts**

## SECTION 5 DIFFERENT BELT CONFIGURATIONS

### 5.1 Double-Sided Twin Power Belt Drives

Timing belts are also available in double-sided designs, which offer an infinite number of new design possibilities on computer equipment, business machines, office equipment, textile machines and similar light-duty applications. Belts with driving teeth on both sides make it possible to change the direction of rotation of one or more synchronized pulleys with only one belt. The inside and outside teeth are identical as to size and pitch and operate on standard pitch diameter pulleys.

If the belts have nylon facing on both sides, then the same design parameters can be used for the drives on both sides of the belt. In case the outside teeth do not have nylon facing, the horsepower rating of the outside teeth is only 45% of the total load.

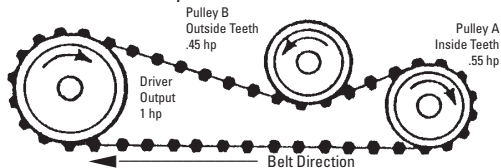

Fig. 11 Double-Sided Timing Belt

For example: assuming the drive pulley and belt are capable of transmitting 1 horsepower, 0.55 hp can be transmitted from the inside teeth of the pulley (A), and 0.45 hp can be transmitted by the outside teeth to pulley (B) for a total of 1 hp, the rated capacity of the driver pulley.

### 5.2 Long Length Timing Belt Stock

These belts are an excellent solution for drives that require belt lengths longer than those produced in conventional endless form. Long length belting has the same basic construction as conventional timing belts. These belts are usually produced by spiral cut of large diameter endless belts. These belts are creatively used in:

- reciprocating carriage drives
- rack and pinion drives
- large plotters

An example of application is shown in **Figure 13**. A complete timing belt and a timing belt segment reduce vibration and chatter in this oscillating drive for a surface grinder.

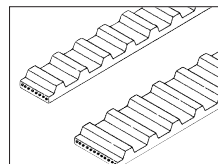

Fig. 12 Timing Belt Stock

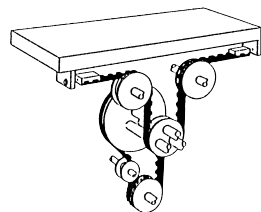

Fig. 13 Example of Timing Belt Stock Use

## SECTION 6 BELT CONSTRUCTION

The load-carrying elements of the belts are the tension members built into the belts (see **Figure 14**). These tension members can be made of:

1. Spirally wound steel wire.
2. Wound glass fibers.
3. Polyester cords.
4. Kevlar.

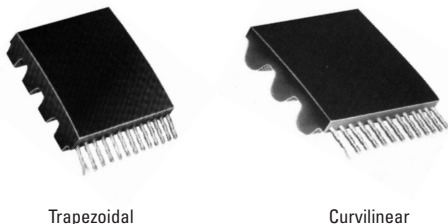

Fig. 14 Belt Construction

The tension members are embedded in neoprene or polyurethane. The neoprene teeth are protected by a nylon fabric facing which makes them wear resistant.

The contributions of the construction members of these belts are as follows:

1. **Tensile Member** – Provides high strength, excellent flex life and high resistance to elongation.
2. **Neoprene Backing** – Strong neoprene bonded to the tensile member for protection against grime, oil and moisture. It also protects from frictional wear if idlers are used on the back of the belt.
3. **Neoprene Teeth** – Shear-resistant neoprene compound is molded integrally with the neoprene backing. They are precisely formed and accurately spaced to assure smooth meshing with the pulley grooves.
4. **Nylon Facing** – Tough nylon fabric with a low coefficient of friction covers the wearing surfaces of the belt. It protects the tooth surfaces and provides a durable wearing surface for long service.

## 6.1 Characteristics Of Reinforcing Fibers

### Polyester

Tensile Strength	160,000 lbf/in. <sup>2</sup>
Elongation at break	14.0%
Modulus (approx.)	2,000,000 lbf/in. <sup>2</sup>

One of the main advantages of polyester cord over higher tensile cords is the lower modulus of polyester, enabling the belt to rotate smoothly over small diameter pulleys. Also, the elastic properties of the material enable it to absorb shock and dampen vibration.

In more and more equipment, stepping motors are being used. Polyester belts have proven far superior to fiberglass or Kevlar reinforced belts in these applications.

High-speed applications with small pulleys are best served by polyester belts under low load.

### Kevlar

Tensile Strength	400,000 lbf/in. <sup>2</sup>
Elongation at break	2.5%
Modulus	18,000,000 lbf/in. <sup>2</sup>

High tensile strength and low elongation make this material very suitable for timing belt applications. Kevlar has excellent shock resistance and high load capacity.

### Fiberglass

Tensile Strength	350,000 lbf/in. <sup>2</sup>
Elongation at break	2.5 – 3.5%
Modulus	10,000,000 lbf/in. <sup>2</sup>

The most important advantages are:

1. High strength
2. Low elongation or stretch
3. Excellent dimensional stability
4. Excellent chemical resistance
5. Absence of creep, 100% elongation recovery

Disadvantages:

1. High modulus (difficult to bend)
2. Brittleness of glass. Improper handling or installation can cause permanent damage
3. Poor shock resistance. No shock absorbing quality when used in timing belts

### Steel

Tensile Strength	360,000 lbf/in. <sup>2</sup>
Elongation at break	2.5%
Modulus (approx.)	15,000,000 lbf/in. <sup>2</sup>

Additional characteristics of tension members and their effect on the drive design are shown in tabulated form in **Table 1**.

**Table 1 Comparison of Different Tension Member Materials \***

E = Excellent      G = Good      F = Fair      P = Poor

Belt Requirements	Nylon	Polyester Cont. Fil. Yarn	Polyester Spun Yarn	Kevlar-Polyester Mix	Kevlar Cont. Fil. Yarn	Kevlar Spun Yarn	Glass	Stainless Steel	Polyester Film Reinforcement
Operate Over Small Pulley	E	G	E	F	P	F	P	P	G
High Pulley Speed	E	E	E	F	P	F	P	P	G
High Intermittent Shock Loading	F	G	G	E	F	E	P	G	F
Vibration Absorption	E	G	E	G	F	F	P	P	F
High Torque Low Speed	P	P	P	F	G	F	E	E	F
Low Belt Stretch	P	P	P	P	G	F	E	E	G
Dimensional Stability	P	P	P	F	G	G	E	E	G
High Temperature 200° F	P	P	P	P	E	E	E	E	F
Low Temperature	F	G	G	G	G	E	E	E	G
Good Belt Tracking	E	G	E	G	F	G	F	P	E
Rapid Start/Stop Operation	F	G	E	G	P	G	P	E	G
Close Center-Distance Tolerance	P	P	P	P	G	F	E	E	G
Elasticity Required in Belt	E	G	E	G	P	P	P	P	P

\* Courtesy of Chemiflex, Inc.

## 6.2 Cord Twist And Its Effect On The Drive

There is a specific reason for not applying the yarn directly in the form of untwisted filaments around the mold. If the filament would be applied continuously, the top and bottom of the belt body would be prevented from being properly joined, and separation could result. See Figure 15.

Two strands each composed of several filaments are twisted around each other, thus forming a cord which is subsequently wound in a helical spiral around the mold creating a space between subsequent layers, which corresponds to the step of the helix. The two strands, however, can be twisted two ways in order to create an "S" or a "Z" twist construction. See Figure 16.

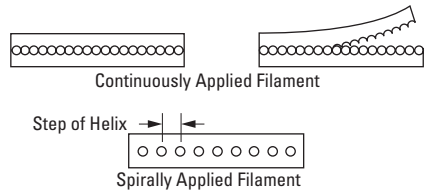

**Fig. 15 Belt Cross Section**

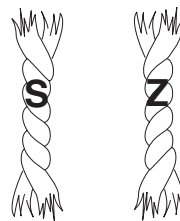

**Fig. 16 Cord Twist**

The "S" twist is obtained if we visualize the two strands being held stationary with our left hand on one end, while a clockwise rotation is imparted by our right hand to the two strands, thus creating a twisted cord. The "Z" twist is obtained similarly, if a counterclockwise rotation is imparted to the two strands.

Different types of cord twist will cause side thrust in opposite directions. The "S" twist will cause a lateral force direction which will obey the "Right-Hand" rule as shown in **Figure 17**.

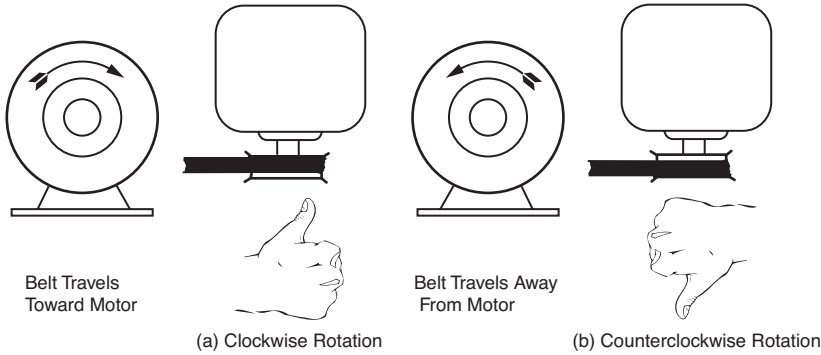

**Fig. 17 Right-Hand Rule Applicable to "S" Twist**

A "Z" type cord twist will produce a direction of lateral force opposite to that of "S" cord. Therefore, in order to produce a belt with minimum lateral force, standard belts are usually made with "S" and "Z" twist construction, in which alternate cords composed of strands twisted in opposite directions are wound in the belt. This is illustrated in **Figure 18**.

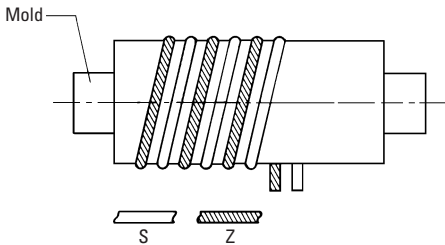

**Fig. 18 "S" and "Z" Cord Lay of the Mold**

The lay of the cord is standard, as shown in **Figure 18**, and it is wound from left to right with the cord being fed under the mold. The smaller the mold diameter and the fewer the strands of cord per inch, the greater the helix angle will be, and the greater the tendency of the lay of the cord to make the belt move to one side.

In general, a standard belt of "S" and "Z" construction, as shown in **Figure 18**, will have a slight tendency to behave as a predominantly "S" twist belt, and will obey the "Right-Hand" rule accordingly.

**6.3 Factors Contributing To Side Travel**

The pulleys in a flat belt drive are crowned to keep the belt running true. Since crowned pulleys are not suitable for a timing belt, the belt will always track to one side. Factors contributing to this condition include:

**I. In the Drive**

1. Misalignment – A belt (any belt – any construction) will normally climb to the high end (or tight) side.
2. Tensioning – In general, lateral travel can be altered or modified by changing tension.
3. Location of plane – Vertical drives have a greater tendency to move laterally due to gravity.

## 6.3 Factors Contributing To Side Travel (Cont.)

- Belt width greater than O.D. of pulley – This condition creates an abnormal degree of lateral travel.
- Belt length – The greater the ratio of length/width of the belt, the less the tendency to move laterally.

### II. In the Belt

- Direction of the lay of the cords in the belt. **See Figure 18.**
- Twist of the strands in the cord. **See Figure 16.**

## 6.4 Characteristics Of Belt Body Materials

Basic characteristics of the three most often used materials are shown in **Table 2**. The tabulated characteristics give rise to the following assessment of these materials:

### Natural Rubber

- High resilience, excellent compression set, good molding properties
- High coefficient of friction; does not yield good ground finish
- High tear strength, low crack growth
- Can withstand low temperatures
- Poor oil and solvent resistance; unusable for ketones and alcohol
- Ozone attacks rubber, but retardants can be added

### Neoprene

- High resilience
- Flame resistant
- Aging good with some natural ozone resistance
- Oil and solvent resistance fair

### Polyurethane

- Excellent wear resistance, poor compression set
- Low coefficient of friction
- Oil and ozone resistance good
- Low-temperature flexibility good
- Not suitable for high temperatures

### Polymer Compound (EPDM), Cream-Colored

- Clean running
- High operating temperature
- Good environmental performance
- Nonmarking
- Quieter functioning

**Table 2 Comparison of Different Belt Body Materials \***

Common Name	Natural Rubber	Neoprene	Urethanes	Cream-Colored Polymer Compound (EPDM)
Chemical Definition	Polyisoprene	Polychloroprene	Polyester/Polyether Urethane	Ethylene Propylene Diene
Durometer Range (Shore A)	30–95	20–95	35-95	30–90
Tensile Strength Range (lbf/in. <sup>2</sup> )	500–3500	500–3000	500-6000	500–2500
Elongation (Max. %)	900	800	900	700
Compression Set	Excellent	Poor to Good	Poor to Good	Poor to Excellent
Resilience Rebound	Excellent	Fair to Good	Poor to Good	Fair to Good
Abrasion Resistance	Good to Excellent	Very Good to Excellent	Excellent	Good
Tear Resistance	Good to Excellent	Good to Excellent	Good to Excellent	Fair to Good
Solvent Resistance	Poor	Fair	Poor	Poor
Oil Resistance	Poor	Fair	Good	Poor
Low Temperature Range (°F)	-70° to -20°	-70° to -30°	-65° to -40°	-60° to -40°
Min. For Continuous Use (°F)	-60°	-80°	-65°	-60°
High Temperature Range (°F)	+180° to +220°	+200° to +250°	+180° to +220°	+220° to +300°
Max. For Continuous (°F)	+180°	+250°	+200°	+300°
Aging Weather - Sunlight	Poor to Fair	Good to Excellent	Good to Excellent	Excellent
Adhesion to Metals	Excellent	Excellent	Excellent	Good to Excellent

\* Courtesy of Robinson Rubber Products

**SECTION 7 BELT TOOTH PROFILES**

There are several belt tooth profiles (**Figure 19, Table 3**) which are the result of different patented features, marketing and production considerations.

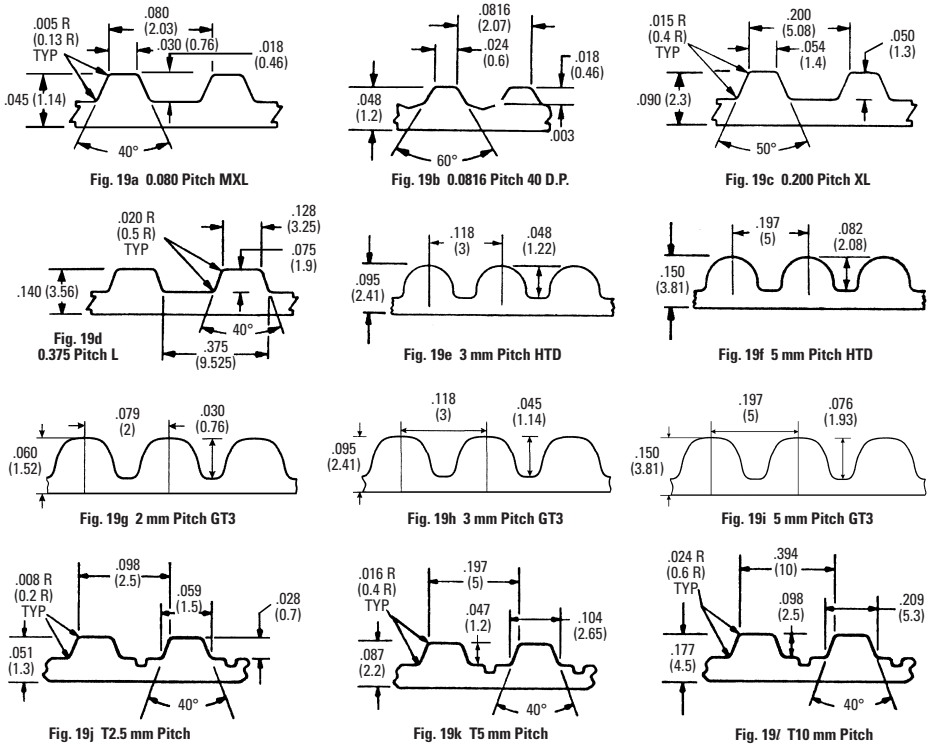

**Fig. 19 Belt Tooth Configuration** Dimensions in ( ) are mm  
**Table 3 Allowable Working Tension of Different Belt Constructions**

	Belt Type	Pitch		Allowable Working Tension Per 1 Inch of Belt Width					
				Neoprene		Urethane/Polyester		Urethane/Kevlar	
		Inch	mm	lbf	N	lbf	N	lbf	N
19a	MXL	0.080	2.03	18	80	20 to 32	89 to 142	32 to 70	142 to 311
19b	40DP	0.0816	2.07	—	—	20 to 32	89 to 142	32 to 70	142 to 311
19c	XL	0.200	5.08	28	125	32	142	40	178
19d	L	0.375	9.525	49	218	—	—	—	—
—	H	0.500	12.7	135	601	—	—	—	—
19e	HTD	0.118	3	64	285	—	—	—	—
19f		0.197	5	102	454	—	—	—	—
—		0.315	8	178	792	—	—	—	—
19g	GT3	0.079	2	25	111	—	—	—	—
19h		0.118	3	114	507	—	—	—	—
19i		0.197	5	160	712	—	—	—	—
—		0.315	8	380	1690	—	—	—	—
—		0.511	14	650	2891	—	—	—	—
19j	T	0.098	2.5*	70	312	—	—	—	—
19k		0.197	5*	209	930	—	—	—	—
19l		0.394	10*	405	1800	—	—	—	—

\* Urethane w/Steel Cords

**NOTE:** For thinner belt widths, less than 1", the tension must be derated since the tension cords on the sides are not complete loops.

For the sake of completeness, the three additional belt profiles shown in **Figure 19j, 19k and 19l** are used in Europe and are sometimes found on machinery imported from Europe and Japan. They are not produced in the U.S.A. and are not covered by RMA standards. The belts are made of polyurethane, and steel is usually used as the tension member.

As described in previous sections, the presently known most advantageous belt tooth configuration is the Gates PowerGrip GT3. This is a result of continuous improvement of the previous HTD tooth profile. The HTD profile is protected by U.S. Patent Number 4,337,056, whereas the GT3 profile is described in U.S. Patent Number 4,515,577.

**Pulleys for these belt profiles are usually available from manufacturers licensed by Gates Rubber Company. Stock Drive Products is one of the companies who can supply a full range of these pulleys as standards or specials, per customers' drawings.**





## SECTION 8 PULLEY PITCH AND OUTSIDE DIAMETERS

Pulley and belt geometry as indicated in **Figure 1** shows reference to a Pitch Circle, which is larger than the pulley itself. Its size is determined by the relationship:

$$pd = \frac{PN}{\pi} \tag{8-1}$$

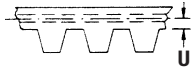
where P is the belt tooth spacing (pitch) and N is the number of teeth on the pulley. The reinforcing cord centerline will coincide with the pulley pitch diameter while the belt is in contact with the pulley. At the same time, the outside diameter of the pulley will be in contact with the bottom of the belt tooth. Hence, the distance "U" between the reinforcing cord centerline and the bottom of the belt tooth will determine the outside diameters of pulleys for different pitches. **See Table 4.**

**Table 4 Basic Belt Dimensions**

Distance from Pitch Line to Belt Tooth Bottom "U"	Common Description	Pulley O.D. O.D. = pd - 2U
.010 inches .007 inches .010 inches .015 inches	0.080" MXL 40 D.P. 1/5" XL 3/8" L	
.015 inches .0225 inches .027 inches	3 mm HTD 5 mm HTD 8 mm HTD	
.010 inches .015 inches .0225 inches	2 mm GT3 3 mm GT3 5 mm GT3	
0.3 millimeters 0.5 millimeters 1.0 millimeters	T2.5 (2.5 mm) T5 (5 mm) T10 (10 mm)	

As previously noted, the pitch and the number of teeth will determine the pitch diameter of the pulley, whereas its outside diameter will depend on the "U" dimension (distance from tooth bottom to centerline of cord) as shown in **Table 4.**

The outside diameter, O.D., is then given by:

$$\text{O.D.} = pd - 2U \quad (8-2)$$

In order to provide fast reference, the following tables show pitch and outside diameters of different pitch pulleys:

**Table 5:** T2.5 (2.5 mm Pitch)\*

**Table 6:** T5 (5 mm Pitch)\*

**Table 7:** T10 (10 mm Pitch)\*

These tables enable the designer to judge immediately the space requirements for a particular drive. In many instances, the torque transmission capability of the drive can be satisfied by a less voluminous solution. This is one of the excellent features of the GT3 profile; it facilitates miniaturization. The size of the small pulley of the drive, however, is subject to some limitations. The suggested minimum size of the pulley related to a particular pitch and rpm is given in **Table 8**.

\* **NOTE:** T2.5, T5 and T10 series have O.D.s and Pitch Diameters which do not conform to equations (8-1) and (8-2).

**Table 5 T2.5 (.098") Pitch Pulley Dimensions**

No. of Grooves	Pitch Diameter		Outside Diameter		No. of Grooves	Pitch Diameter		Outside Diameter	
	Inch	mm	Inch	mm		Inch	mm	Inch	mm
10	.317	8.05	.293	7.45	61	1.915	48.65	1.892	48.05
11	.348	8.85	.325	8.25	62	1.945	49.40	1.921	48.80
12	.378	9.60	.354	9.00	63	1.976	50.20	1.953	49.60
13	.409	10.40	.386	9.80	64	2.008	51.00	1.984	50.40
14	.441	11.20	.417	10.60	65	2.039	51.80	2.016	51.20
15	.472	12.00	.449	11.40	66	2.071	52.60	2.047	52.00
16	.504	12.80	.480	12.20	67	2.102	53.40	2.079	52.80
17	.535	13.60	.512	13.00	68	2.134	54.20	2.110	53.60
18	.567	14.40	.543	13.80	69	2.165	55.00	2.142	54.40
19	.598	15.20	.575	14.60	70	2.197	55.80	2.173	55.20
20	.630	16.00	.606	15.40	71	2.228	56.60	2.205	56.00
21	.661	16.80	.638	16.20	72	2.260	57.40	2.236	56.80
22	.693	17.60	.669	17.00	73	2.291	58.20	2.268	57.60
23	.724	18.40	.701	17.80	74	2.321	58.95	2.297	58.35
24	.754	19.15	.730	18.55	75	2.352	59.75	2.329	59.15
25	.785	19.95	.762	19.35	76	2.384	60.55	2.360	59.95
26	.817	20.75	.793	20.15	77	2.415	61.35	2.392	60.75
27	.848	21.55	.825	20.95	78	2.447	62.15	2.423	61.55
28	.880	22.35	.856	21.75	79	2.478	62.95	2.455	62.35
29	.911	23.15	.888	22.55	80	2.510	63.75	2.486	63.15
30	.943	23.95	.919	23.35	81	2.541	64.55	2.518	63.95
31	.974	24.75	.951	24.15	82	2.573	65.35	2.549	64.75
32	1.006	25.55	.982	24.95	83	2.604	66.15	2.581	65.55
33	1.037	26.35	1.014	25.75	84	2.636	66.95	2.612	66.35
34	1.069	27.15	1.045	26.55	85	2.667	67.75	2.644	67.15
35	1.100	27.95	1.077	27.35	86	2.699	68.55	2.675	67.95
36	1.132	28.75	1.108	28.15	87	2.728	69.30	2.705	68.70
37	1.161	29.50	1.138	28.90	88	2.760	70.10	2.736	69.50
38	1.193	30.30	1.169	29.70	89	2.791	70.90	2.768	70.30
39	1.224	31.10	1.201	30.50	90	2.823	71.70	2.799	71.10
40	1.256	31.90	1.232	31.30	91	2.854	72.50	2.831	71.90
41	1.287	32.70	1.264	32.10	92	2.886	73.30	2.862	72.70
42	1.319	33.50	1.295	32.90	93	2.917	74.10	2.894	73.50
43	1.350	34.30	1.327	33.70	94	2.949	74.90	2.925	74.30
44	1.382	35.10	1.358	34.50	95	2.980	75.70	2.957	75.10
45	1.413	35.90	1.390	35.30	96	3.012	76.50	2.988	75.90
46	1.445	36.70	1.421	36.10	97	3.043	77.30	3.020	76.70
47	1.476	37.50	1.453	36.90	98	3.075	78.10	3.051	77.50
48	1.508	38.30	1.484	37.70	99	3.104	78.85	3.081	78.25
49	1.537	39.05	1.514	38.45	100	3.136	79.65	3.112	79.05
50	1.569	39.85	1.545	39.25	101	3.167	80.45	3.144	79.85
51	1.600	40.65	1.577	40.05	102	3.199	81.25	3.175	80.65
52	1.632	41.45	1.608	40.85	103	3.230	82.05	3.207	81.45
53	1.663	42.25	1.640	41.65	104	3.262	82.85	3.238	82.25
54	1.695	43.05	1.671	42.45	105	3.293	83.65	3.270	83.05
55	1.726	43.85	1.703	43.25	106	3.325	84.45	3.301	83.85
56	1.758	44.65	1.734	44.05	107	3.356	85.25	3.333	84.65
57	1.789	45.45	1.766	44.85	108	3.388	86.05	3.364	85.45
58	1.821	46.25	1.797	45.65	109	3.419	86.85	3.396	86.25
59	1.852	47.05	1.829	46.45	110	3.451	87.65	3.427	87.05
60	1.884	47.85	1.860	47.25	111	3.482	88.45	3.459	87.85

**Table 6 T5 (.197") Pitch Pulley Dimensions**

No. of Grooves	Pitch Diameter		Outside Diameter		No. of Grooves	Pitch Diameter		Outside Diameter	
	Inch	mm	Inch	mm		Inch	mm	Inch	mm
10	.632	16.05	.593	15.05	61	3.829	97.25	3.789	96.25
11	.695	17.65	.656	16.65	62	3.892	98.85	3.852	97.85
12	.758	19.25	.719	18.25	63	3.955	100.45	3.915	99.45
13	.821	20.85	.781	19.85	64	4.018	102.05	3.978	101.05
14	.884	22.45	.844	21.45	65	4.081	103.65	4.041	102.65
15	.947	24.05	.907	23.05	66	4.142	105.20	4.102	104.20
16	1.008	25.60	.969	24.60	67	4.205	106.80	4.165	105.80
17	1.071	27.20	1.031	26.20	68	4.268	108.40	4.228	107.40
18	1.134	28.80	1.094	27.80	69	4.331	110.00	4.291	109.00
19	1.197	30.40	1.157	29.40	70	4.394	111.60	4.354	110.60
20	1.260	32.00	1.220	31.00	71	4.457	113.20	4.417	112.20
21	1.323	33.60	1.283	32.60	72	4.518	114.75	4.478	113.75
22	1.384	35.15	1.344	34.15	73	4.581	116.35	4.541	115.35
23	1.447	36.75	1.407	35.75	74	4.644	117.95	4.604	116.95
24	1.510	38.35	1.470	37.35	75	4.707	119.55	4.667	118.55
25	1.573	39.95	1.533	38.95	76	4.770	121.15	4.730	120.15
26	1.636	41.55	1.596	40.55	77	4.833	122.75	4.793	121.75
27	1.699	43.15	1.659	42.15	78	4.896	124.35	4.856	123.35
28	1.762	44.75	1.722	43.75	79	4.957	125.90	4.917	124.90
29	1.823	46.30	1.783	45.30	80	5.020	127.50	4.980	126.50
30	1.886	47.90	1.846	46.90	81	5.083	129.10	5.043	128.10
31	1.949	49.50	1.909	48.50	82	5.146	130.70	5.106	129.70
32	2.012	51.10	1.972	50.10	83	5.209	132.30	5.169	131.30
33	2.075	52.70	2.035	51.70	84	5.272	133.90	5.232	132.90
34	2.138	54.30	2.098	53.30	85	5.333	135.45	5.293	134.45
35	2.199	55.85	2.159	54.85	86	5.396	137.05	5.356	136.05
36	2.262	57.45	2.222	56.45	87	5.459	138.65	5.419	137.65
37	2.325	59.05	2.285	58.05	88	5.522	140.25	5.482	139.25
38	2.388	60.65	2.348	59.65	89	5.585	141.85	5.545	140.85
39	2.451	62.25	2.411	61.25	90	5.648	143.45	5.608	142.45
40	2.514	63.85	2.474	62.85	91	5.709	145.00	5.669	144.00
41	2.575	65.40	2.535	64.40	92	5.772	146.60	5.732	145.60
42	2.638	67.00	2.598	66.00	93	5.835	148.20	5.795	147.20
43	2.701	68.60	2.661	67.60	94	5.898	149.80	5.858	148.80
44	2.764	70.20	2.724	69.20	95	5.961	151.40	5.921	150.40
45	2.827	71.80	2.787	70.80	96	6.024	153.00	5.984	152.00
46	2.890	73.40	2.850	72.40	97	6.085	154.55	6.045	153.55
47	2.951	74.95	2.911	73.95	98	6.148	156.15	6.108	155.15
48	3.014	76.55	2.974	75.55	99	6.211	157.75	6.171	156.75
49	3.077	78.15	3.037	77.15	100	6.273	159.34	6.234	158.34
50	3.140	79.75	3.100	78.75	101	6.337	160.95	6.297	159.95
51	3.203	81.35	3.163	80.35	102	6.400	162.55	6.360	161.55
52	3.266	82.95	3.226	81.95	103	6.463	164.15	6.423	163.15
53	3.329	84.55	3.289	83.55	104	6.524	165.70	6.484	164.70
54	3.390	86.10	3.350	85.10	105	6.587	167.30	6.547	166.30
55	3.453	87.70	3.413	86.70	106	6.650	168.90	6.610	167.90
56	3.516	89.30	3.476	88.30	107	6.713	170.50	6.673	169.50
57	3.579	90.90	3.539	89.90	108	6.776	172.10	6.736	171.10
58	3.642	92.50	3.602	91.50	109	6.839	173.70	6.799	172.70
59	3.705	94.10	3.665	93.10	110	6.900	175.25	6.860	174.25
60	3.766	95.65	3.726	94.65	111	6.963	176.85	6.923	175.85

**Table 7 T10 (.394") Pitch Pulley Dimensions**

No. of Grooves	Pitch Diameter		Outside Diameter		No. of Grooves	Pitch Diameter		Outside Diameter	
	Inch	mm	Inch	mm		Inch	mm	Inch	mm
10	1.259	31.98	1.180	29.98	61	7.650	194.30	7.571	192.30
11	1.384	35.16	1.306	33.16	62	7.776	197.50	7.697	195.50
12	1.510	38.35	1.431	36.35	63	7.902	200.70	7.823	198.70
13	1.636	41.55	1.557	39.55	64	8.026	203.85	7.947	201.85
14	1.760	44.70	1.681	42.70	65	8.169	207.50	8.090	205.50
15	1.886	47.90	1.807	45.90	66	8.278	210.25	8.199	208.25
16	2.012	51.10	1.933	49.10	67	8.402	213.40	8.323	211.40
17	2.136	54.25	2.057	52.25	68	8.528	216.60	8.449	214.60
18	2.262	57.45	2.183	55.45	69	8.654	219.80	8.575	217.80
19	2.388	60.65	2.309	58.65	70	8.778	222.95	8.699	220.95
20	2.512	63.80	2.433	61.80	71	8.904	226.15	8.825	224.15
21	2.638	67.00	2.559	65.00	72	9.030	229.35	8.950	227.35
22	2.764	70.20	2.685	68.20	73	9.154	232.50	9.075	230.50
23	2.888	73.35	2.809	71.35	74	9.280	235.70	9.201	233.70
24	3.014	76.55	2.935	74.55	75	9.406	238.90	9.327	236.90
25	3.140	79.75	3.061	77.75	76	9.530	242.05	9.451	240.05
26	3.264	82.90	3.185	80.90	77	9.656	245.25	9.577	243.25
27	3.390	86.10	3.311	84.10	78	9.780	248.40	9.701	246.40
28	3.514	89.25	3.435	87.25	79	9.906	251.60	9.827	249.60
29	3.640	92.45	3.561	90.45	80	10.031	254.80	9.953	252.80
30	3.766	95.65	3.687	93.65	81	10.156	257.95	10.077	255.95
31	3.890	98.80	3.811	96.80	82	10.281	261.15	10.203	259.15
32	4.016	102.00	3.937	100.00	83	10.407	264.35	10.329	262.35
33	4.142	105.20	4.063	103.20	84	10.531	267.50	10.453	265.50
34	4.266	108.35	4.187	106.35	85	10.657	270.70	10.579	268.70
35	4.392	111.55	4.313	109.55	86	10.783	273.90	10.705	271.90
36	4.518	114.75	4.439	112.75	87	10.907	277.05	10.829	275.05
37	4.642	117.90	4.563	115.90	88	11.033	280.25	10.955	278.25
38	4.768	121.10	4.689	119.10	89	11.159	283.45	11.081	281.45
39	4.894	124.30	4.815	122.30	90	11.283	286.60	11.205	284.60
40	5.018	127.45	4.939	125.45	91	11.409	289.80	11.331	287.80
41	5.144	130.65	5.065	128.65	92	11.535	293.00	11.457	291.00
42	5.270	133.85	5.191	131.85	93	11.659	296.15	11.581	294.15
43	5.394	137.00	5.315	135.00	94	11.785	299.35	11.707	297.35
44	5.520	140.20	5.441	138.20	95	11.911	302.55	11.833	300.55
45	5.646	143.40	5.567	141.40	96	12.035	305.70	11.957	303.70
46	5.770	146.55	5.691	144.55	97	12.161	308.90	12.083	306.90
47	5.896	149.75	5.817	147.75	98	12.287	312.10	12.209	310.10
48	6.022	152.95	5.943	150.95	99	12.411	315.25	12.333	313.25
49	6.146	156.10	6.067	154.10	100	12.537	318.45	12.459	316.45
50	6.272	159.30	6.193	157.30	101	12.663	321.65	12.585	319.65
51	6.398	162.50	6.319	160.50	102	12.787	324.80	12.709	322.80
52	6.522	165.65	6.443	163.65	103	12.913	328.00	12.835	326.00
53	6.648	168.85	6.569	166.85	104	13.039	331.20	12.961	329.20
54	6.774	172.05	6.695	170.05	105	13.163	334.35	13.085	332.35
55	6.898	175.20	6.819	173.20	106	13.289	337.55	13.211	335.55
56	7.024	178.40	6.945	176.40	107	13.415	340.75	13.337	338.75
57	7.150	181.60	7.071	179.60	108	13.539	343.90	13.461	341.90
58	7.274	184.75	7.195	182.75	109	13.665	347.10	13.587	345.10
59	7.400	187.95	7.321	185.95	110	13.791	350.30	13.713	348.30
60	7.526	191.15	7.447	189.15	111	13.915	353.45	13.837	351.45

**Table 8 Minimum Pulley Diameters**

Belt Type	Pitch		Max. rpm	Suggested Minimum *		
	Inch	mm		No. of Grooves	Pitch Diameter	
					Inch	mm
MXL	.080	2.03	10000	14	.357	9.07
			7500	12	.306	7.77
			5000	11	.280	7.11
			3500	10	.255	6.48
XL	.200	5.08	3500	12	.764	19.41
			1750	11	.700	17.78
			1160	10	.637	16.18
L	.375	9.525	3500	16	1.910	48.51
			1750	14	1.671	42.44
			1160	12	1.432	36.37
H	.500	12.7	3500	20	3.182	80.82
			1750	18	2.865	72.77
			1160	16	2.546	64.67
HTD®	.118	3	3500	20	.752	19.1
			1750	18	.677	17.2
			1160	17	.639	16.23
	.197	5	3500	30	1.880	47.75
			1750	26	1.629	41.38
			1160	22	1.379	35.03
	.315	8	3500	32	3.208	81.48
			1750	28	2.807	71.3
			1160	24	2.406	61.11
GT®3	.079	2	14000	16	.401	10.19
			7500	14	.351	8.92
			5000	12	.301	7.65
	.118	3	5000	20	.752	19.1
			2800	18	.677	17.2
			1600	16	.602	15.29
	.197	5	2000	22	1.379	35.03
			1400	20	1.253	31.83
			1000	18	1.128	28.65
T	.098	2.5	3600	14	.417	10.6
			1800			
			1200			
	< 1200	5	3600	14	.844	21.45
			1800			
			1200			
	< 1200	10	3600	16	1.931	49.05
			1800			
			1200			
< 1200	18	2.183	55.45			

\* Smaller pulleys than shown under "Suggested Minimum" may be used if a corresponding reduction in belt life is satisfactory. Use of pulleys smaller than those shown will be at customers' own responsibility for performance and belt life.

## SECTION 9 DESIGN AND INSTALLATION SUGGESTIONS

There are some general guidelines which are applicable to all timing belts, including miniature and double-sided belts:

1. Drives should always be designed with ample reserve horsepower capacity. Use of overload service factors is important. Belts should be rated at only 1/15th of their respective ultimate strength.
2. For MXL pitch belts, the smallest recommended pulley will have 10 teeth. For other pitches, **Table 8**, on the previous page, should be used.
3. The pulley diameter should never be smaller than the width of the belt.
4. Belts with Fibrex-glass fiber tension members should not be subjected to sharp bends or rough handling, since this could cause breakage of the fibers.
5. In order to deliver the rated horsepower, a belt must have six or more teeth in mesh with the grooves of the smaller pulley. The number of teeth in mesh may be obtained by formula given in **SECTION 24 TIMING BELT DRIVE SELECTION PROCEDURE**. The shear strength of a single tooth is only a fraction of the belt break strength.
6. Because of a slight side thrust of synchronous belts in motion, at least one pulley in the drive must be flanged. When the center distance between the shafts is 8 or more times the diameter of the smaller pulley, or when the drive is operating on vertical shafts, both pulleys should be flanged.
7. Belt surface speed should not exceed 5500 feet per minute (28 m/s) for larger pitch belts and 10000 feet per minute (50 m/s) for minipitch belts. For the HTD belts, a speed of 6500 feet per minute (33 m/s) is permitted, whereas for GT3 belts, the maximum permitted speed is 7500 feet per minute (38 m/s). The maximum allowable operating speed for T series is 4000 feet per minute (20 m/s).
8. Belts are, in general, rated to yield a minimum of 3000 hours of useful life if all instructions are properly followed.
9. Belt drives are inherently efficient. It can be assumed that the efficiency of a synchronous belt drive is greater than 95%.
10. Belt drives are usually a source of noise. The frequency of the noise level increases proportionally with the belt speed. The higher the initial belt tension, the greater the noise level. The belt teeth entering the pulleys at high speed act as a compressor and this creates noise. Some noise is the result of a belt rubbing against the flange, which in turn may be the result of the shafts not being parallel. As shown in **Figure 9** (page T-9), the noise level is substantially reduced if the PowerGrip GT3 belt is being used.
11. If the drive is part of a sensitive acoustical or electronics sensing or recording device, it is recommended that the back surfaces of the belt be ground to assure absolutely uniform belt thickness.
12. For some applications, no backlash between the driving and the driven shaft is permitted. For these cases, special profile pulleys can be produced without any clearance between the belt tooth and pulley. This may shorten the belt life, but it eliminates backlash. **Figure 10** (page T-9) shows the superiority of PowerGrip GT3 profile as far as reduction of backlash is concerned.
13. Synchronous belts are often driven by stepping motors. These drives are subjected to continuous and large accelerations and decelerations. If the belt reinforcing fiber, i.e., tension member, as well as the belt material, have high tensile strength and no elongation, the belt will not be instrumental in absorbing the shock loads. This will result in sheared belt teeth. Therefore, take this into account when the size of the smallest pulley and the materials for the belt and tension member are selected.
14. The choice of the pulley material (metal vs. plastic) is a matter of price, desired precision, inertia, color, magnetic properties and, above all, personal preference based on experiences. Plastic pulleys with metal inserts or metal hubs represent a good compromise.

The following precautions should be taken when installing all timing belt drives:

1. Timing belt installation should be a snug fit, neither too tight nor too loose. The positive grip of the belt eliminates the need for high initial tension. Consequently, a belt, when installed with a snug fit (that is, not too taut) assures longer life, less bearing wear and quieter operation. Preloading (often the cause of premature failure) is not necessary.  
When torque is unusually high, a loose belt may "jump teeth" on starting. In such a case, the tension should be increased gradually, until satisfactory operation is attained. A good rule of thumb for installation tension is as shown in **Figure 20**, and the corresponding tensioning force is shown in **Table 9**, both shown in **SECTION 10 BELT TENSIONING**. For widths other than shown, increase force proportionally to the belt width. Instrumentation for measuring belt tension is available. Consult the product section of this catalog.
2. Be sure that shafts are parallel and pulleys are in alignment. On a long center drive, it is sometimes advisable to offset the driven pulley to compensate for the tendency of the belt to run against one flange.
3. On a long center drive, it is imperative that the belt sag is not large enough to permit teeth on the slack side to engage the teeth on the tight side.
4. It is important that the frame supporting the pulleys be rigid at all times. A nonrigid frame causes variation in center distance and resulting belt slackness. This, in turn, can lead to jumping of teeth – especially under starting load with shaft misalignment.
5. Although belt tension requires little attention after initial installation, provision should be made for some center distance adjustment for ease in installing and removing belts. Do not force belt over flange of pulley.
6. Idlers, either of the inside or outside type, are not recommended and should not be used except for power takeoff or functional use. When an idler is necessary, it should be on the slack side of the belt. Inside idlers must be grooved, unless their diameters are greater than an equivalent 40-groove pulley. Flat idlers must not be crowned (use edge flanges). Idler diameters must exceed the smallest diameter drive pulley. Idler arc of contact should be held to a minimum.

In addition to the general guidelines enumerated previously, specific operating characteristics of the drive must be taken into account. These may include the following:

### 9.1 Low-Speed Operation

Synchronous drives are especially well-suited for low-speed, high torque applications. Their positive driving nature prevents potential slippage associated with V-belt drives, and even allows significantly greater torque carrying capability. Small pitch synchronous drives operating at speeds of 50 ft./min. (0.25 m/s) or less are considered to be low-speed. Care should be taken in the drive selection process as stall and peak torques can sometimes be very high. While intermittent peak torques can often be carried by synchronous drives without special considerations, high cyclic peak torque loading should be carefully reviewed.

Proper belt installation tension and rigid drive bracketry and framework is essential in preventing belt tooth jumping under peak torque loads. It is also helpful to design with more than the normal minimum of 6 belt teeth in mesh to ensure adequate belt tooth shear strength.

Newer generation curvilinear systems like PowerGrip GT3 and PowerGrip HTD should be used in low-speed, high torque applications, as trapezoidal timing belts are more prone to tooth jumping, and have significantly less load carrying capacity.

### 9.2 High-Speed Operation

Synchronous belt drives are often used in high-speed applications even though V-belt drives are typically better suited. They are often used because of their positive driving characteristic (no creep or slip), and because they require minimal maintenance (don't stretch significantly). A significant drawback of high-speed synchronous drives is drive noise. High-speed synchronous drives will nearly always produce more noise than V-belt drives. Small pitch synchronous drives operating at speeds in excess of 1300 ft./min. (6.6 m/s) are considered to be high-speed.

Special consideration should be given to high-speed drive designs, as a number of factors can significantly influence belt performance. Cord fatigue and belt tooth wear are the two most significant factors that must be controlled to ensure success. Moderate pulley diameters should be used to reduce the rate of cord flex fatigue. Designing with a smaller pitch belt will often provide better cord flex fatigue characteristics than a larger pitch belt. PowerGrip GT3 is especially well suited for high-speed drives because of its excellent belt tooth entry/exit characteristics. Smooth interaction between the belt tooth and pulley groove minimizes wear and noise. Belt installation tension is especially critical with high-speed drives. Low belt tension allows the belt to ride out of the driven pulley, resulting in rapid belt tooth and pulley groove wear.

### 9.3 Smooth Running

Some ultrasensitive applications require the belt drive to operate with as little vibration as possible, as vibration sometimes has an effect on the system operation or finished manufactured product. In these cases, the characteristics and properties of all appropriate belt drive products should be reviewed. The final drive system selection should be based upon the most critical design requirements, and may require some compromise.

Vibration is not generally considered to be a problem with synchronous belt drives. Low levels of vibration typically result from the process of tooth meshing and/or as a result of their high tensile modulus properties. Vibration resulting from tooth meshing is a normal characteristic of synchronous belt drives, and cannot be completely eliminated. It can be minimized by avoiding small pulley diameters, and instead choosing moderate sizes. The dimensional accuracy of the pulleys also influences tooth meshing quality. Additionally, the installation tension has an impact on meshing quality. PowerGrip GT3 drives mesh very cleanly, resulting in the smoothest possible operation. Vibration resulting from high tensile modulus can be a function of pulley quality. Radial run out causes belt tension variation with each pulley revolution. V-belt pulleys are also manufactured with some radial run out, but V-belts have a lower tensile modulus resulting in less belt tension variation. The high tensile modulus found in synchronous belts is necessary to maintain proper pitch under load.

### 9.4 Drive Noise

Drive noise evaluation in any belt drive system should be approached with care. There are many potential sources of noise in a system, including vibration from related components, bearings, and resonance and amplification through framework and panels.

Synchronous belt drives typically produce more noise than V-belt drives. Noise results from the process of belt tooth meshing and physical contact with the pulleys. The sound pressure level generally increases as operating speed and belt width increase, and as pulley diameter decreases. Drives designed on moderate pulley sizes without excessive capacity (overdesigned) are generally the quietest. PowerGrip GT3 drives have been found to be significantly quieter than other systems due to their improved meshing characteristic (see **Figure 9**, page T-9). Polyurethane belts generally produce more noise than neoprene belts. Proper belt installation tension is also very important in minimizing drive noise. The belt should be tensioned at a level that allows it to run with as little meshing interference as possible.

Drive alignment also has a significant effect on drive noise. Special attention should be given to minimizing angular misalignment (shaft parallelism). This assures that belt teeth are loaded uniformly and minimizes side tracking forces against the flanges. Parallel misalignment (pulley offset) is not as critical of a concern as long as the belt is not trapped or pinched between opposite flanges (see the special section dealing with drive alignment). Pulley materials and dimensional accuracy also influence drive noise. Some users have found that steel pulleys are the quietest, followed closely by aluminum. Polycarbonates have been found to be noisier than metallic materials. Machined pulleys are generally quieter than molded pulleys. The reasons for this revolve around material density and resonance characteristics as well as dimensional accuracy.

### 9.5 Static Conductivity

Small synchronous rubber or urethane belts can generate an electrical charge while operating on a drive. Factors such as humidity and operating speed influence the potential of the charge. If determined to be a problem, rubber belts can be produced in a conductive construction to dissipate the charge into the pulleys, and to ground. This prevents the accumulation of electrical charges that might be detrimental to material handling processes or sensitive electronics. It also greatly reduces the potential for arcing or sparking in

flammable environments. Urethane belts cannot be produced in a conductive construction.

RMA has outlined standards for conductive belts in their bulletin IP-3-3. Unless otherwise specified, a static conductive construction for rubber belts is available on a made-to-order basis. Unless otherwise specified, conductive belts will be built to yield a resistance of 300,000 ohms or less, when new.

Nonconductive belt constructions are also available for rubber belts. These belts are generally built specifically to the customers conductivity requirements. They are generally used in applications where one shaft must be electrically isolated from the other.

It is important to note that a static conductive belt cannot dissipate an electrical charge through plastic pulleys. At least one metallic pulley in a drive is required for the charge to be dissipated to ground. A grounding brush or similar device may also be used to dissipate electrical charges.

Urethane timing belts are not static conductive and cannot be built in a special conductive construction. Special conductive rubber belts should be used when the presence of an electrical charge is a concern.

## 9.6 Operating Environments

Synchronous drives are suitable for use in a wide variety of environments. Special considerations may be necessary, however, depending on the application.

**Dust:** Dusty environments do not generally present serious problems to synchronous drives as long as the particles are fine and dry. Particulate matter will, however, act as an abrasive resulting in a higher rate of belt and pulley wear. Damp or sticky particulate matter deposited and packed into pulley grooves can cause belt tension to increase significantly. This increased tension can impact shafting, bearings, and framework. Electrical charges within a drive system can sometimes attract particulate matter.

**Debris:** Debris should be prevented from falling into any synchronous belt drive. Debris caught in the drive is generally either forced through the belt or results in stalling of the system. In either case, serious damage occurs to the belt and related drive hardware.

**Water:** Light and occasional contact with water (occasional wash downs) should not seriously affect synchronous belts. Prolonged contact (constant spray or submersion) results in significantly reduced tensile strength in fiberglass belts, and potential length variation in aramid belts. Prolonged contact with water also causes rubber compounds to swell, although less than with oil contact. Internal belt adhesion systems are also gradually broken down with the presence of water. Additives to water, such as lubricants, chlorine, anticorrosives, etc. can have a more detrimental effect on the belts than pure water. Urethane timing belts also suffer from water contamination. Polyester tensile cord shrinks significantly and experiences loss of tensile strength in the presence of water. Aramid tensile cord maintains its strength fairly well, but experiences length variation. Urethane swells more than neoprene in the presence of water. This swelling can increase belt tension significantly, causing belt and related hardware problems.

**Oil:** Light contact with oils on an occasional basis will not generally damage synchronous belts. Prolonged contact with oil or lubricants, either directly or airborne, results in significantly reduced belt service life. Lubricants cause the rubber compound to swell, breakdown internal adhesion systems, and reduce belt tensile strength. While alternate rubber compounds may provide some marginal improvement in durability, it is best to prevent oil from contacting synchronous belts.

**Ozone:** The presence of ozone can be detrimental to the compounds used in rubber synchronous belts. Ozone degrades belt materials in much the same way as excessive environmental temperatures. Although the rubber materials used in synchronous belts are compounded to resist the effects of ozone, eventually chemical breakdown occurs and they become hard and brittle and begin cracking. The amount of degradation depends upon the ozone concentration and duration of exposure. For good performance of rubber belts, the following concentration levels should not be exceeded: (parts per hundred million)

Standard Construction:	100 ppm
Nonmarking Construction:	20 ppm
Conductive Construction:	75 ppm
Low Temperatures Construction:	20 ppm

**Radiation:** Exposure to gamma radiation can be detrimental to the compounds used in rubber and urethane synchronous belts. Radiation degrades belt materials much the same way excessive environmental temperatures do. The amount of degradation depends upon the intensity of radiation and the exposure time. For good belt performance, the following exposure levels should not be exceeded:

Standard Construction:	10 <sup>8</sup> rads
Nonmarking Construction:	10 <sup>4</sup> rads
Conductive Construction:	10 <sup>6</sup> rads
Low Temperatures Construction:	10 <sup>4</sup> rads

**Dust Generation:** Rubber synchronous belts are known to generate small quantities of fine dust, as a natural result of their operation. The quantity of dust is typically higher for new belts, as they run in. The period of time for run in to occur depends upon the belt and pulley size, loading and speed. Factors such as pulley surface finish, operating speeds, installation tension, and alignment influence the quantity of dust generated.

**Clean Room:** Rubber synchronous belts may not be suitable for use in clean room environments, where all potential contamination must be minimized or eliminated. Urethane timing belts typically generate significantly less debris than rubber timing belts. However, they are recommended only for light operating loads. Also, they cannot be produced in a static conductive construction to allow electrical charges to dissipate.

**Static Sensitive:** Applications are sometimes sensitive to the accumulation of static electrical charges. Electrical charges can affect material handling processes (like paper and plastic film transport), and sensitive electronic equipment. Applications like these require a static conductive belt, so that the static charges generated by the belt can be dissipated into the pulleys, and to ground. Standard rubber synchronous belts do not meet this requirement, but can be manufactured in a static conductive construction on a made-to-order basis. Normal belt wear resulting from long term operation or environmental contamination can influence belt conductivity properties.

In sensitive applications, rubber synchronous belts are preferred over urethane belts since urethane belting cannot be produced in a conductive construction.

## 9.7 Belt Tracking

Lateral tracking characteristics of synchronous belts is a common area of inquiry. While it is normal for a belt to favor one side of the pulleys while running, it is abnormal for a belt to exert significant force against a flange resulting in belt edge wear and potential flange failure. Belt tracking is influenced by several factors. In order of significance, discussion about these factors is as follows:

**Tensile Cord Twist:** Tensile cords are formed into a single twist configuration during their manufacture. Synchronous belts made with only single twist tensile cords track laterally with a significant force. To neutralize this tracking force, tensile cords are produced in right- and left-hand twist (or "S" and "Z" twist) configurations. Belts made with "S" twist tensile cords track in the opposite direction to those built with "Z" twist cord. Belts made with alternating "S" and "Z" twist tensile cords track with minimal lateral force because the tracking characteristics of the two cords offset each other. The content of "S" and "Z" twist tensile cords varies slightly with every belt that is produced. As a result, every belt has an unprecedented tendency to track in either one direction or the other. When an application requires a belt to track in one specific direction only, a single twist construction is used. See **Figures 16 & 17**, previously shown, on pages T-12 and T-13.

**Angular Misalignment:** Angular misalignment, or shaft nonparallelism, cause synchronous belts to track laterally. The angle of misalignment influences the magnitude and direction of the tracking force. Synchronous belts tend to track "downhill" to a state of lower tension or shorter center distance.

**Belt Width:** The potential magnitude of belt tracking force is directly related to belt width. Wide belts tend to track with more force than narrow belts.

**Pulley Diameter:** Belts operating on small pulley diameters can tend to generate higher tracking forces than on large diameters. This is particularly true as the belt width approaches the pulley diameter. Drives with pulley diameters less than the belt width are not generally recommended because belt tracking forces can become excessive.

**Belt Length:** Because of the way tensile cords are applied on to the belt molds, short belts can tend to exhibit higher tracking forces than long belts. The helix angle of the tensile cord decreases with increasing belt length.

**Gravity:** In drive applications with vertical shafts, gravity pulls the belt downward. The magnitude of this force is minimal with small pitch synchronous belts. Sag in long belt spans should be avoided by applying adequate belt installation tension.

**Torque Loads:** Sometimes, while in operation, a synchronous belt will move laterally from side to side on the pulleys rather than operating in a consistent position. While not generally considered to be a significant concern, one explanation for this is varying torque loads within the drive. Synchronous belts sometimes track differently with changing loads. There are many potential reasons for this; the primary cause is related to tensile cord distortion while under pressure against the pulleys. Variation in belt tensile loads can also cause changes in framework deflection, and angular shaft alignment, resulting in belt movement.

**Belt Installation Tension:** Belt tracking is sometimes influenced by the level of belt installation tension. The reasons for this are similar to the effect that varying torque loads have on belt tracking.

When problems with belt tracking are experienced, each of these potential contributing factors should be investigated in the order that they are listed. In most cases, the primary problem will probably be identified before moving completely through the list.

## 9.8 Pulley Flanging

Pulley guide flanges are necessary to keep synchronous belts operating on their pulleys. As discussed previously in **Section 9.7** on belt tracking, it is normal for synchronous belts to favor one side of the pulleys when running.

Proper flange design is important in preventing belt edge wear, minimizing noise and preventing the belt from climbing out of the pulley. Dimensional recommendations for custom-made or molded flanges are included in tables dealing with these issues.

Proper flange placement is important so that the belt is adequately restrained within its operating system. Because design and layout of small synchronous drives is so diverse, the wide variety of flanging situations potentially encountered cannot easily be covered in a simple set of rules without finding exceptions. Despite this, the following broad flanging guidelines should help the designer in most cases:

**Two Pulley Drives:** On simple two pulley drives, either one pulley should be flanged on both sides, or each pulley should be flanged on opposite sides.

**Multiple Pulley Drives:** On multiple pulley (or serpentine) drives, either every other pulley should be flanged on both sides, or every pulley should be flanged on alternating sides around the system.

**Vertical Shaft Drives:** On vertical shaft drives, at least one pulley should be flanged on both sides, and the remaining pulleys should be flanged on at least the bottom side.

**Long Span Lengths:** Flanging recommendations for small synchronous drives with long belt span lengths cannot easily be defined due to the many factors that can affect belt tracking characteristics. Belts on drives with long spans (generally 12 times the diameter of the smaller pulley or more) often require more lateral restraint than with short spans. Because of this, it is generally a good idea to flange the pulleys on both sides.

**Large Pulleys:** Flanging large pulleys can be costly. Designers often wish to leave large pulleys unflanged to reduce cost and space. Belts generally tend to require less lateral restraint on large pulleys than small and can often perform reliably without flanges. When deciding whether or not to flange, the previous guidelines should be considered. The groove face width of unflanged pulleys should also be greater than with flanged pulleys. See **Table 27**, on page **T-47** for recommendations.

**Idlers:** Flanging of idlers is generally not necessary. Idlers designed to carry lateral side loads from belt tracking forces can be flanged, if needed, to provide lateral belt restraint. Idlers used for this purpose can be used on the inside or backside of the belts. The previous guidelines should also be considered.

## 9.9 Registration

The three primary factors contributing to belt drive registration (or positioning) errors are belt elongation, backlash, and tooth deflection. When evaluating the potential registration capabilities of a synchronous belt drive, the system must first be determined to be either static or dynamic in terms of its registration function and requirements.

**Static Registration:** A static registration system moves from its initial static position to a secondary static position. During the process, the designer is concerned only with how accurately and consistently the drive arrives at its secondary position. He/she is not concerned with any potential registration errors that occur during transport. Therefore, the primary factor contributing to registration error in a static registration system is backlash. The effects of belt elongation and tooth deflection do not have any influence on the registration accuracy of this type of system.

**Dynamic Registration:** A dynamic registration system is required to perform a registering function while in motion with torque loads varying as the system operates. In this case, the designer is concerned with the rotational position of the drive pulleys with respect to each other at every point in time. Therefore, belt elongation, backlash and tooth deflection will all contribute to registrational inaccuracies.

Further discussion about each of the factors contributing to registration error is as follows:

**Belt Elongation:** Belt elongation, or stretch, occurs naturally when a belt is placed under tension. The total tension exerted within a belt results from installation, as well as working loads. The amount of belt elongation is a function of the belt tensile modulus, which is influenced by the type of tensile cord and the belt construction. The standard tensile cord used in rubber synchronous belts is fiberglass. Fiberglass has a high tensile modulus, is dimensionally stable, and has excellent flex-fatigue characteristics. If a higher tensile modulus is needed, aramid tensile cords can be considered, although they are generally used to provide resistance to harsh shock and impulse loads. Aramid tensile cords used in small synchronous belts generally have only a marginally higher tensile modulus in comparison to fiberglass. When needed, belt tensile modulus data is available from our Application Engineering Department.

**Backlash:** Backlash in a synchronous belt drive results from clearance between the belt teeth and the pulley grooves. This clearance is needed to allow the belt teeth to enter and exit the grooves smoothly with a minimum of interference. The amount of clearance necessary depends upon the belt tooth profile. Trapezoidal Timing Belt Drives are known for having relatively little backlash. PowerGrip HTD Drives have improved torque carrying capability and resist ratcheting, but have a significant amount of backlash. PowerGrip GT3 Drives have even further improved torque carrying capability, and have as little or less backlash than trapezoidal timing belt drives. In special cases, alterations can be made to drive systems to further decrease backlash. These alterations typically result in increased belt wear, increased drive noise and shorter drive life. Contact our Application Engineering Department for additional information.

**Tooth Deflection:** Tooth deformation in a synchronous belt drive occurs as a torque load is applied to the system, and individual belt teeth are loaded. The amount of belt tooth deformation depends upon the amount of torque loading, pulley size, installation tension and belt type. Of the three primary contributors to registration error, tooth deflection is the most difficult to quantify. Experimentation with a prototype drive system is the best means of obtaining realistic estimations of belt tooth deflection.

Additional guidelines that may be useful in designing registration critical drive systems are as follows:

- Select PowerGrip GT3 or trapezoidal timing belts.
- Design with large pulleys with more teeth in mesh.
- Keep belts tight, and control tension closely.
- Design frame/shafting to be rigid under load.
- Use high quality machined pulleys to minimize radial runout and lateral wobble.

## SECTION 10 BELT TENSIONING

### 10.1 What Is Proper Installation Tension

One of the benefits of small synchronous belt drives is lower belt pre-tensioning in comparison to comparable V-belt drives, but proper installation tension is still important in achieving the best possible drive performance. In general terms, belt pre-tensioning is needed for proper belt/pulley meshing to prevent belt ratcheting under peak loading, to compensate for initial belt tension decay, and to prestress the drive framework. The amount of installation tension that is actually needed is influenced by the type of application as well as the system design. Some general examples of this are as follows:

**Motion Transfer Drives:** Motion transfer drives, by definition, are required to carry extremely light torque loads. In these applications, belt installation tension is needed only to cause the belt to conform to and mesh properly with the pulleys. The amount of tension necessary for this is referred to as the minimum tension ( $T_{st}$ ). Minimum tensions, on a per span basis, are included in **Table 9**, on page T-30. Some motion transfer drives carry very little torque, but have a need for accurate registration requirements. These systems may require additional static (or installation) tension in order to minimize registration error.

**Normal Power Transmission Drives:** Normal power transmission drives should be designed in accordance with published torque ratings and a reasonable service factor (between 1.5 and 2.0). In these applications, belt installation tension is needed to allow the belt to maintain a proper fit with the pulleys while under load, and to prevent belt ratcheting under peak loads. For these drives, proper installation tension can be determined using two different approaches. If torque loads are known and well defined, and an accurate tension value is desired, **Equation (10-1)** or **Equation (10-2)** should be used. If the torque loads are not as well defined, and a quick value is desired for use as a starting point, values from **Table 10** can be used. All static tension values are on a per span basis.

$$T_{st} = \frac{0.812 DQ}{d} + mS^2 \quad (\text{lbf}) \quad (10-1)$$

(For drives with a Service Factor of 1.3 or greater)

$$T_{st} = \frac{1.05 DQ}{d} + mS^2 \quad (\text{lbf}) \quad (10-2)$$

(For drives with a Service Factor less than 1.3)

where:  $T_{st}$  = Static tension per span (lbf)  
 $DQ$  = Driver design torque (lbf in.)  
 $d$  = Driver pitch diameter (in.)  
 $S$  = Belt speed/1000 (ft./min.)  
 where Belt speed = (Driver pitch diameter x Driver rpm)/3.82  
 $m$  = Mass factor from **Table 9**

**Table 9 Belt Tensioning Force**

Belt	Belt Width	<i>m</i>	<i>Y</i>	Minimum $T_{st}$ (lbf) Per Span
2 mm GT3	4 mm	0.026	1.37	1.3
	6 mm	0.039	2.05	2.0
	9 mm	0.058	3.08	3.0
	12 mm	0.077	4.10	4.0
3 mm GT3	6 mm	0.077	3.22	2.2
	9 mm	0.120	4.83	3.3
	12 mm	0.150	6.45	4.4
	15 mm	0.190	8.06	5.5
5 mm GT3	9 mm	0.170	14.9	8.4
	15 mm	0.280	24.9	14.1
	20 mm	0.380	33.2	18.7
	25 mm	0.470	41.5	23.4
3 mm HTD	6 mm	0.068	3.81	2.5
	9 mm	0.102	5.71	4.3
	15 mm	0.170	9.52	7.8
5 mm HTD	9 mm	0.163	14.9	6.3
	15 mm	0.272	24.9	12.0
	25 mm	0.453	41.5	21.3
MXL	1/8"	0.003	1.40	1.0
	3/16"	0.004	2.11	1.7
	1/4"	0.005	2.81	2.3
XL	1/4"	0.010	3.30	3.2
	3/8"	0.015	4.94	5.1
L	1/2"	0.19	10.00	13.0
	3/4"	0.29	18.00	19.0
	1"	0.38	25.00	25.0
T2.5	4 mm		0.3	0.2
	6 mm	*	0.55	0.45
	10 mm		1.05	0.92
T5	6 mm		7	2.25
	10 mm	*	17	5.62
	16 mm		27	8.99
T10	16 mm		73	24.73
	25 mm	*	133	44.96

NOTE: *Y* = constant used in Equations (10-4) and (10-5).

\* Not available at press time.

**Registration Drives:** Registration drives are required to register, or position accurately. Higher belt installation tensions help in increasing belt tensile modulus as well as in increasing meshing interference, both of which reduce backlash. Tension values for these applications should be determined experimentally to confirm that desired performance characteristics have been achieved. As a beginning point, use values from **Table 10** multiplied by 1.5 to 2.0.

**Table 10 Static Belt Tension,  $T_{st}$  (lbf) Per Span – General Values**

Belt	4 mm	6 mm	9 mm	12 mm	15 mm	20 mm	25 mm
2 mm GT3	2	3	4	5	—	—	—
3 mm GT3	—	8	11	15	19	25	—
5 mm GT3	—	—	18	22	27	35	43
3 mm HTD	—	5	9	12	16	22	—
5 mm HTD	—	—	13	18	24	33	43
T2.5	0.34	0.67	1.37	—	—	—	—
T5	—	3	7	—	12	—	—
T10	—	—	—	—	28	—	41

Belt	1/8"	3/16"	1/4"	5/16"	3/8"	7/16"	1/2"
MXL	2	3	3	4	5	—	—
XL	2	3	4	5	6	8	9

Most synchronous belt applications often exhibit their own individual operating characteristics. The static installation tensions recommended in this section should serve as a general guideline in determining the level of tension required. The drive system should be thoroughly tested to confirm that it performs as intended.

**10.2 Making Measurements**

Belt installation tension is generally measured in the following ways:

**Force/Deflection:** Belt span tension can be measured by deflecting a belt span 1/64" per inch (0.4 mm per 25 mm) of span length at midspan, with a known force (see **Figure 20**). This method is generally convenient, but not always very accurate, due to difficulty in measuring small deflections and forces common in small synchronous drives. The force/deflection method is most effective on larger drives with long span lengths. The static (or installation) tension ( $T_{st}$ ) can either be calculated from **Equation (10-1)** or **Equation (10-2)**, or selected from **Table 9** or **Table 10**. The deflection forces can be calculated from **Equation (10-4)** and **Equation (10-5)**. The span length can either be calculated from **Equation (10-3)**, or measured. If the calculated static tension is less than the minimum  $T_{st}$  values in **Table 9**, use the minimum values.

$$t = \sqrt{CD^2 - \left(\frac{PD - pd}{2}\right)^2} \tag{10-3}$$

where:  $t$  = Span length (in.)  
 $CD$  = Drive center distance (in.)  
 $PD$  = Large pitch diameter (in.)  
 $pd$  = Small pitch diameter (in.)

$$\text{Deflection force, Min.} = \frac{T_{st} + \left(\frac{t}{L}\right) Y}{16} \text{ (lbf)} \tag{10-4}$$

$$\text{Deflection force, Max.} = \frac{1.1 T_{st} + \left(\frac{t}{L}\right) Y}{16} \text{ (lbf)} \tag{10-5}$$

where:  $T_{st}$  = Static tension (lbf)  
 $t$  = Span length (in.)  
 $L$  = Belt pitch length (in.)  
 $Y$  = Constant, from **Table 9**

**Shaft Separation:** Belt installation tension can be applied directly by exerting a force against either the driver or driven shaft in a simple 2-point drive system (see **Figure 21**). The resulting belt tension will be as accurate as the force applied to driver or driven shaft. This method is considerably easier to perform than the force/deflection method and, in some cases, more accurate.

In order to calculate the required shaft separation force, the proper static tension (on a per span basis) should first be determined as previously discussed. This tension value will be present in both belt spans as tension is applied. The angle of the spans with respect to the movable shaft should then be determined. The belt spans should be considered to be vectors (force with direction), and be summed into a single tension vector force (see **Figure 22**). Refer to **SECTION 14 BELT PULL AND BEARING LOADS** for further instructions on summing vectors.

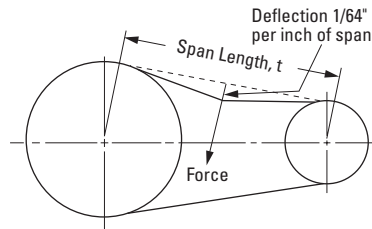

**Fig. 20 Force/Deflection Method** (10-4)

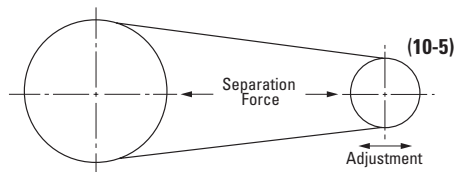

**Fig. 21 Shaft Separation Method**

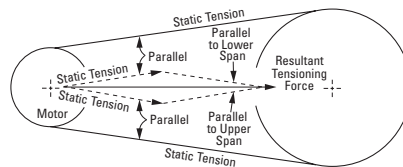

**Fig. 22 Single Tension Vector Force**

**Idler Force:** Belt installation tension can also be applied by exerting a force against an idler pulley within the system that is used to take up belt slack (see **Figure 23**). This force can be applied manually, or with a spring. Either way, the idler should be locked down after the appropriate tension has been applied.

Calculating the required force will involve a vector analysis as described previously in the shaft separation section.

**Sonic Tension Meter:** The Sonic Tension Meter (**Figure 24**) is an electronic device that measures the natural frequency of a free stationary belt span and instantly computes the static belt tension based upon the belt span length, belt width, and belt type. This provides accurate and repeatable tension measurements while using a nonintrusive procedure (the measurement process itself doesn't change the belt span tension). A measurement is made simply by plucking the belt while holding the sensor close to the vibrating belt span.

The unit is about the size of a portable phone (8-1/8" long x 3-3/4" wide x 1-3/8" thick or 206mm long x 95mm wide x 35mm thick) so it can be easily handled. The sensor is about 1/2" (13mm) in diameter for use in cramped spaces, and the unit is either battery operated for portability or AC operated for production use. The unit measures virtually all types of light power and precision belts. An automatic gain adjustment allows measurements to be made in environments with high noise levels. A fully powered meter is necessary for optimal microphone sensitivity. The meter has 3 settings standard (10 to 600 Hz), high (500 to 5000 Hz), and low (10 to 50 Hz), but is normally set to standard. It is best to know the target belt span frequency, but the appropriate range can be selected through trial and error. Data can also be collected through an IBM Compatible RS-232 serial port, if desired. For additional details, see the product manual or page in the catalog.

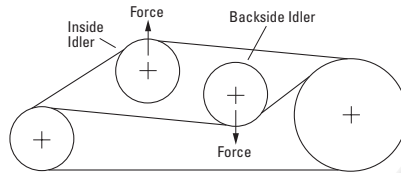

**Fig. 23 Idler Forces**



**Fig. 24 Sonic Tension Meter**

## SECTION 11 DRIVE ALIGNMENT

### 11.1 Angular And Parallel

Drive misalignment is one of the most common sources of drive performance problems. Misaligned drives can exhibit symptoms such as high belt tracking forces, uneven belt tooth wear, high noise levels, and tensile cord failure. The two primary types of drive misalignment are angular and parallel. Discussion about each of these types are as follows:

**Angular:** Angular misalignment results when the drive shafts are not parallel (see **Figure 25**). As a result, the belt tensile cords are not loaded evenly, resulting in uneven tooth/land pressure and wear. The edge cords on the high tension side are often overloaded which may cause an edge cord failure that propagates across the entire belt width. Angular misalignment often results in high belt-tracking forces as well which cause accelerated belt edge wear,

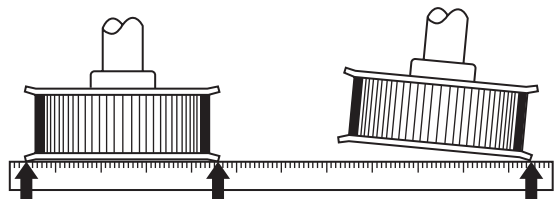

**Fig. 25 Angular Misalignment**

sometimes leading to flange failure or belts tracking off of the pulleys.

**Parallel:** Parallel misalignment results from pulleys being mounted out of line from each other (see **Figure 26**). Parallel misalignment is generally more of a concern with V-type belts than with synchronous belts because V-type belts run in grooves and are unable to free float on the pulleys. Synchronous belts will generally free float on the pulleys and essentially self-align themselves as they run. This self-aligning can occur as long as the pulleys have sufficient groove face width beyond the width of the belts. If not, the belts can become trapped between opposite pulley flanges causing serious performance problems. Parallel misalignment is not generally a significant concern with synchronous drives as long as the belts do not become trapped or pinched between opposite flanges. For recommendations on groove face width, see **Table 37**, on page T-75.

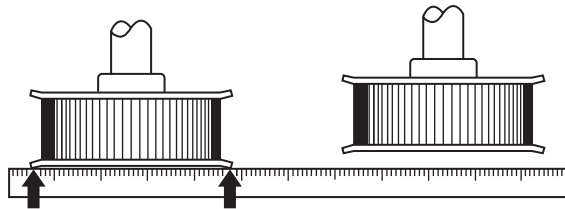

**Fig. 26 Parallel Misalignment**

**Allowable Misalignment:** In order to maximize performance and reliability, synchronous drives should be aligned closely. This is not, however, always a simple task in a production environment. The maximum allowable misalignment, angular and parallel combined, is  $1/4^\circ$ .

## 11.2 Practical Tips

Angular misalignment is not always easy to measure or quantify. It is sometimes helpful to use the observed tracking characteristics of a belt, to make a judgment as to the system's relative alignment. Neutral tracking "S" and "Z" synchronous belts generally tend to track "down hill" or to a state of lower tension or shorter center distance when angularly misaligned. This may not always hold true since neutral tracking belts naturally tend to ride lightly against either one flange or the other due to numerous factors discussed in the section on belt tracking. This tendency will generally hold true with belts that track hard against a flange. In those cases, the shafts will require adjustment to correct the problem.

Parallel misalignment is not often found to be a problem in synchronous belt drives. If clearance is always observable between the belt and all flanges on one side, then parallel misalignment should not be a concern.

## SECTION 12 INSTALLATION AND TAKE-UP

### 12.1 Installation Allowance

When designing a drive system for a manufactured product, allowance for belt installation must be built into the system. While specific installation allowances could be published, as they are for larger industrial belt drives, small synchronous drive applications are generally quite diverse, making it nearly impossible to arrive at values that apply in all cases. When space is at a premium, the necessary installation allowance should be determined experimentally using actual production parts for the best possible results.

### 12.2 Belt Installation

During the belt installation process, it is very important that the belt be fully seated in the pulley grooves before applying final tension. Serpentine drives with multiple pulleys and drives with large pulleys are particularly vulnerable to belt tensioning problems resulting from the belt teeth being only partially engaged in the pulleys during installation. In order to prevent these problems, the belt installation tension should be evenly distributed to all belt spans by rotating the system by hand. After confirming that belt teeth are properly engaged in the pulley grooves, belt tension should be rechecked and verified. Failure to do this may result in an undertensioned condition with the potential for belt ratcheting.

## 12.3 Belt Take-up

Synchronous belt drives generally require little if any retensioning when used in accordance with proper design procedures. A small amount of belt tension decay can be expected within the first several hours of operation. After this time, the belt tension should remain relatively stable.

## 12.4 Fixed Center Drives

Designers sometimes attempt to design synchronous belt drive systems without any means of belt adjustment or take-up. This type of system is called a Fixed Center Drive. While this approach is often viewed as being economical, and is simple for assemblers, it often results in troublesome reliability and performance problems in the long run.

The primary pitfall in a fixed center design approach is failure to consider the effects of system tolerance accumulation. Belts and pulleys are manufactured with industry accepted production tolerances. There are limits to the accuracy that the center distance can be maintained on a production basis as well. The potential effects of this tolerance accumulation is as follows:

### Low Tension:

*Long Belt with Small Pulleys on a Short Center Distance*

### High Tension:

*Short Belt with Large Pulleys on a Long Center Distance*

Belt tension in these two cases can vary by a factor of 3 or more with a standard fiberglass tensile cord. This potential variation is great enough to overload bearings and shafting, as well as the belts themselves. The probability of these extremes occurring is a matter of statistics, but however remote the chances may seem, they will occur in a production setting. In power transmission drives, the appearance of either extreme is very likely to impact drive system performance in a negative manner.

The most detrimental aspect of fixed center drives is generally the potentially high tension condition. This condition can be avoided by adjusting the design center distance. A common approach in these designs is to reduce the center distance from the exact calculated value by some small fraction. This results in a drive system that is inherently loose, but one that has much less probability of yielding excessively high shaft loads.

**NOTE:** This approach should not be used for power transmission drives since the potentially loose operating conditions could result in accelerated wear and belt ratcheting, even under nominal loading.

There are times when fixed center drive designs can't be avoided. In these cases, the following recommendations will maximize the probability of success.

1. Do not use a fixed center design for power transmission drives. Consider using a fixed center design only for lightly loaded or motion transfer applications.
2. Do not use a fixed center design for drives requiring high motion quality or registration precision.
3. When considering a fixed center design, the center distance must be held as accurately as possible, typically within 0.002" – 0.003" (0.05 mm – 0.08 mm). This accuracy often requires the use of stamped steel framework. Molding processes do not generally have the capacity to maintain the necessary accuracy.
4. Pulleys for fixed center systems should be manufactured with a process that is capable of producing the required O.D. tolerances accurately enough.
5. The performance capabilities of the drive system should be verified by testing belts produced over their full length tolerance range on drive systems representing the full potential center-distance variation.

## SECTION 13 IDLER USAGE

Idlers in synchronous belt drives are commonly used to take up belt slack, apply installation tension or to clear obstructions within a system. While idlers cause additional belt bending, resulting in fatigue, this effect is generally not significant as long as proper design procedures are followed. Synchronous belts elongate very little over time, making them relatively maintenance free. All idlers should be capable of being locked down after being adjusted and should require little additional attention. Specific guidelines and recommendations are given below.

### 13.1 Inside/Outside

Inside idlers are generally preferred over backside idlers from a belt fatigue standpoint. Both are commonly used with good success. Inside idlers should be pulleys, but can be flat, if the O.D. is equivalent to the pitch diameter of a 40-groove pulley. Backside idlers should be flat and uncrowned.

### 13.2 Tight Side/Slack Side

Idlers should be placed on the slack (or nonload-carrying) side, if possible. Their effect on belt fatigue is less on the slack side than on the tight (or load-carrying) side. If spring-loaded idlers are used, they should never be placed on the tight side (see Spring-Loaded Idlers). Also, note that drive direction reversals cause the tight and slack spans to reverse, potentially placing the idler on the tight side.

### 13.3 Idler Placement

In synchronous belt drives, idlers can be placed nearly anywhere they are needed. Synchronous drives are much less sensitive to idler placement and belt wrap angles than V-belt drives. The designer should make sure that at least 6 belt teeth are in mesh on load-carrying pulleys. For every tooth in mesh less than this (with a minimum of 2), 20% of the belt torque rating must be subtracted. In order to minimize the potential for belt ratcheting, each loaded pulley in the system should also have a wrap angle of at least 60°. If a loaded pulley has less than 6 teeth in mesh and 60° of wrap, idlers can often be used to improve this condition. Nonloaded idler pulleys do not have tooth meshing or wrap angle restriction.

### 13.4 Spring-Loaded Idlers

Using a spring to apply a predetermined force against a tensioning idler to obtain proper belt installation tension is acceptable as long as the idler can be locked down after belt installation.

Dynamic spring-loaded idlers are generally not recommended for synchronous belt drives. If used, spring-loaded belt idlers should never be used on the tight (or load-carrying) side. Tight side tensions vary with the magnitude and type of load carried by the system. High tight side tensions can overcome the idler spring force allowing the belt to ratchet. In order to prevent this from occurring, an excessively high spring force is required. This high spring force can result in high shaft/bearing loads and accelerated belt wear.

If dynamic spring-loaded idlers are to be used, they should be used on the slack (or nonload-carrying) side of the drive. Potential drive loading variations in the system will have the least possible impact on idler movement due to spring compression with the idler placed in this way. Be sure to note that the tight and slack spans shift as the direction of drive rotation reverses. This could place the spring-loaded idler on the tight side. In some cases, drive vibration and harmonic problems may also be encountered with the use of spring-loaded idlers.

### 13.5 Size Recommendations

Inside idler pulleys can be used in the minimum recommended size for each particular belt pitch. Inside flat idlers can be used on the tooth side of synchronous belts as long as they are of a diameter equivalent to

## 13.5 Size Recommendations (Continued)

the pitch diameter of a 40-groove pulley in the same pitch. Drives with inside flat idlers should be tested, as noise and belt wear may occur. Flat backside idlers should be used with diameters at least 30% larger than the minimum recommended inside pulley size.

Table 11 summarizes our idler size recommendations.

**Table 11 Idler Size Recommendations**

Belt Type	Minimum Inside Idler	Minimum Backside Idler O.D.		Minimum Inside Flat Idler O.D.	
		inch	mm	inch	mm
<b>MXL</b>	12 grooves	0.50	12.7	1.00	25.4
<b>XL</b>	12 grooves	1.00	25.4	2.50	63.5
<b>3 mm HTD</b>	12 grooves	0.75	19.1	1.50	38.1
<b>5 mm HTD</b>	14 grooves	1.25	31.8	2.50	63.5
<b>2 mm GT3</b>	12 grooves	0.50	12.7	1.00	25.4
<b>3 mm GT3</b>	12 grooves	0.75	19.1	1.50	38.1
<b>5 mm GT3</b>	14 grooves	1.25	31.8	2.50	63.5
<b>T2.5</b>	14* or 16 $\Delta$ grooves	.57* or .66 $\Delta$	14.6* or 16.7 $\Delta$	1.26	31.9
<b>T5</b>	14* or 16 $\Delta$ grooves	1.15* or 1.31 $\Delta$	29.2* or 33.3 $\Delta$	2.51	63.85
<b>T10</b>	16* or 18 $\Delta$ grooves	2.64* or 2.94 $\Delta$	67* or 74.7 $\Delta$	5.02	127.45

\* Above 1200 rpm,  $\Delta$  Below 1200 rpm

## 13.6 Specifying Shaft Locations In Multipoint Drive Layouts

When collecting geometrical layout data for multiple pulley drive layouts, it is important to use a standard approach that is readily understood and usable for drive design calculations. This is of particular importance when the data will be provided to our Application Engineering Department for analysis.

### 2-Point Drive

When working with a simple 2-point drive (driver/driven only) it is sufficient to specify the desired distance between shaft centers for belt length calculations.

### 3-Point Drive

When working with a 3-point drive (driver/driven/idler), X-Y coordinates are desirable. It is sufficient, however, to specify desired center distances between each of the three shaft centers to form a triangle. In either case, pulley/idler movement details for belt tensioning and take up are also necessary.

### Multi-Point Drive

When working with a drive system having more than 3 shafts, the geometrical layout data must be collected in terms of X-Y coordinates for analysis. For those unfamiliar with X-Y coordinates, the X-Y Cartesian coordinate system is commonly used in mathematical and engineering calculations and utilizes a horizontal and vertical axis as illustrated in Figure 27.

The axes cross at the zero point, or origin. Along the horizontal, or "X" axis, all values to the right of the zero point are positive, and all values to the left of the zero point are negative. Along the vertical, or "Y" axis, all values above the zero point are positive, and all values below the zero point are negative. This is also illustrated in Figure 27.

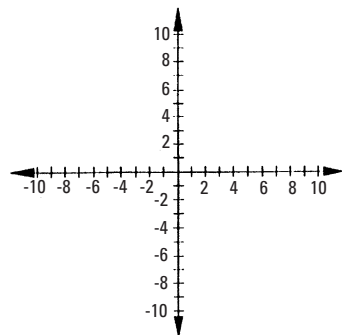

**Fig. 27 Cartesian Coordinate System**

When identifying a shaft center location, each X-Y coordinate is specified with a measurement in the "X" as well as the "Y" direction. This requires a horizontal and vertical measurement for each shaft center in order to establish a complete coordinate. Either English or Metric units of measurement may be used.

A complete coordinate is specified as follows:

(X, Y)

(13-1)

where: X = measurement along X-axis (horizontal)  
Y = measurement along Y-axis (vertical)

In specifying X and Y coordinates for each shaft center, the origin (zero point) must first be chosen as a reference. The driver shaft most often serves this purpose, but any shaft center can be used. Measurements for all remaining shaft centers must be taken from this origin or reference point. The origin is specified as (0, 0).

An example layout of a 5-point drive system is illustrated in **Figure 28**. Here, each of the five shaft centers are located and identified on the X-Y coordinate grid.

When specifying parameters for the movable or adjustable shaft (for belt installation and tensioning), the following approaches are generally used:

**Fixed Location:** Specify the nominal shaft location coordinate with a movement direction.

**Slotted Location:** Specify a location coordinate for the beginning of the slot, and a location coordinate for the end of the slot along its path of linear movement.

**Pivoted Location:** Specify the initial shaft location coordinate along with a pivot point location coordinate and the pivot radius.

Performing belt length and idler movement/positioning calculations by hand can be quite difficult and time consuming. With a complete geometrical drive description, we can make the drive design and layout process quite simple for you.

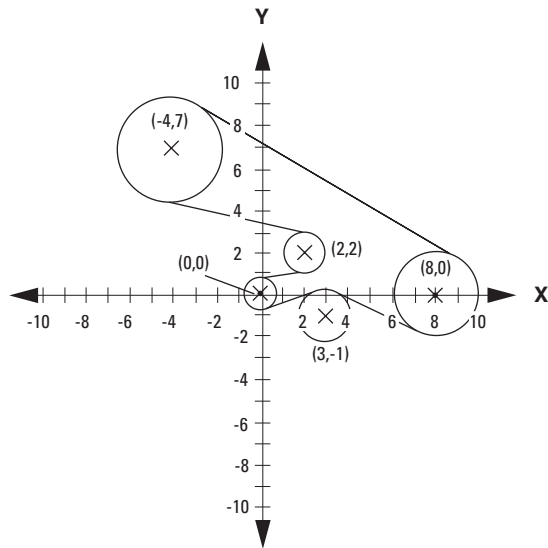

Fig. 28 Example of 5-Point Drive System

## SECTION 14 BELT PULL AND BEARING LOADS

Synchronous belt drives are capable of exerting lower shaft loads than V-belt drives in some circumstances. If pre-tensioned according to recommendations for a fully loaded steady state condition, synchronous and V-belt drives will generate comparable shaft loads. If the actual torque loads are reduced and the level of pre-tension remains the same, they will continue to exert comparable shaft loads. In some cases, synchronous belts can be pre-tensioned for less than full loads, under nonsteady state conditions,

with reasonable results. Reduced pre-tensioning in synchronous belts can be warranted in a system that operates with uniform loads most of the time, but generates peak loads on an intermittent basis. While V-belt drives require pre-tensioning based upon peak loads to prevent slippage, synchronous drive pre-tensioning can be based upon lower average loads rather than intermittent peak loads, as long as the belt does not ratchet under the peak loads. When the higher peak loads are carried by the synchronous drive, the belt will self-generate tension as needed to carry the load. The process of self-tensioning results in the belt teeth riding out of the pulley grooves as the belt enters the driven pulley on the slack side, resulting in increased belt tooth and pulley wear. As long as peak loads occur intermittently and belts do not ratchet, reduced installation tension will result in reduced average belt pull without serious detrimental effects. Synchronous belts generally require less pretension than V-belts for the same load. They do not require additional installation tension for belt wrap less than 180 degrees on loaded pulleys as V-belt drives do. In most cases, these factors contribute to lower static and dynamic shaft loads in synchronous belt drives.

Designers often wish to calculate how much force a belt drive will exert on the shafting/ bearings/ framework in order to properly design their system. It is difficult to make accurate belt pull calculations because factors such as torque load variation, installation tension and pulley runout all have a significant influence. Estimations, however, can be made as follows:

### 14.1 Motion Transfer Drives

Motion transfer drives, by definition, do not carry a significant torque load. As a result, the belt pull is dependent only on the installation tension. Because installation tensions are provided on a per span basis, the total belt pull can be calculated by vector addition.

### 14.2 Power Transmission Drives

Torque load and installation tension both influence the belt pull in power transmission drives. The level of installation tension influences the dynamic tension ratio of the belt spans. The tension ratio is defined as the tight side (or load carrying) tension  $T_T$  divided by the slack side (or nonload carrying) tension  $T_S$ . Synchronous belt drives are generally pre-tensioned to operate dynamically at a 5:1 tension ratio in order to provide the best possible performance. After running for a short time, this ratio is known to increase somewhat as the belt runs in and seats with the pulleys, reducing tension. Equations (14-1) and (14-2) can be used to calculate the estimated  $T_T$  and  $T_S$  tensions assuming a 5:1 tension ratio.  $T_T$  and  $T_S$  tensions can then be summed into a single vector force and direction.

$$T_T = \frac{2.5(Q)}{Pd} \text{ (lbf)} \quad (14-1)$$

$$T_S = \frac{0.5(Q)}{Pd} \text{ (lbf)} \quad (14-2)$$

where:  $T_T$  = Tight side tension (lbf)  
 $T_S$  = Slack side tension (lbf)  
 $Q$  = Torque Load (lbf in.)  
 $Pd$  = Pitch diameter (in.)

If both direction and magnitude of belt pull are required, the vector sum of  $T_T$  and  $T_S$  can be found by graphical vector addition as shown in **Figure 29**.  $T_T$  and  $T_S$  vectors are drawn parallel to the tight and slack sides at a convenient scale. The magnitude and direction of the resultant vector, or belt pull, can then be measured graphically.

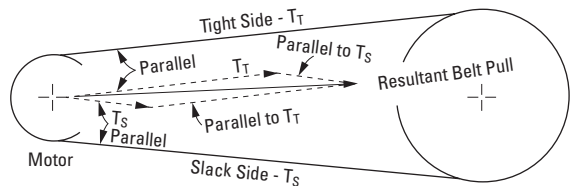

**Fig. 29 Belt Pull Vector Diagram**

The same procedures can be used for finding belt pull on the driven shaft. This method can also be used for drives using three or more pulleys or idlers.

For two pulley drives, belt pull on the driver and driven shafts is equal but opposite in direction. For drives using idlers, both magnitude and direction may be different. If only the magnitude of the belt pull is needed in a two pulley drive, use the following procedure:

1. Add  $T_T$  and  $T_S$
2. Using the value of  $(D - d)/C$  for the drive, find the vector sum correction factor using **Figure 30**. Or, use the known arc of contact on the small pulley, where:
  - $D$  = large diameter
  - $d$  = small diameter
  - $C$  = center distance
3. Multiply the sum of  $T_T$  and  $T_S$  by the vector sum correction factor to find the vector sum, or belt pull.

For drives using idlers, either use the graphical method or contact our Application Engineering Department for assistance.

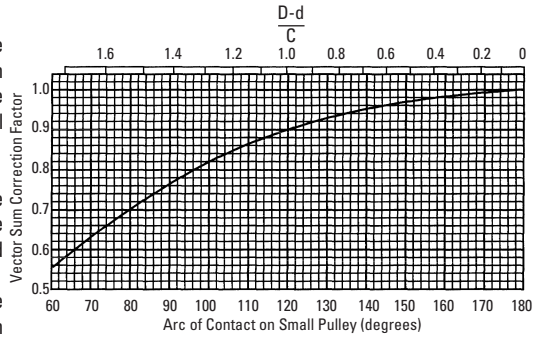

**Fig. 30 Vector Sum Correction Factor**

### 14.3 Registration Drives

Synchronous belt drives used for purposes of accurate registration or synchronization generally require the use of higher than normal installation tensions (see section on Belt Tensioning). These drives will operate with higher belt pulls than normal power transmission drives. Belt pull values for these types of applications should be verified experimentally, but can be estimated by adding the installation tension in each belt span vectorially.

### 14.4 Bearing Load Calculations

In order to find actual bearing loads, it is necessary to know the weights of machine components and the value of all other forces contributing to the load. However, sometimes it helps to know the bearing load contributed by the belt drive alone. The resulting bearing load due to belt pull can be calculated if both bearing spacing with respect to the pulley center and the belt pull are known. For approximate bearing load calculations, machine designers use belt pull and ignore pulley weight forces. If more accurate bearing load calculations are needed, or if the pulley is unusually heavy, the actual shaft load (including pulley weight) should be used.

#### A. Overhung Pulleys (See Figure 31)

$$B_1 = \frac{Fb}{a} \quad (14-3)$$

$$B_2 = \frac{F(a + b)}{a} \quad (14-4)$$

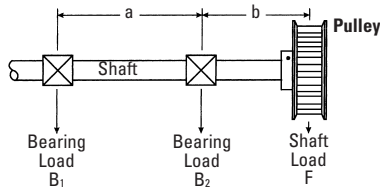
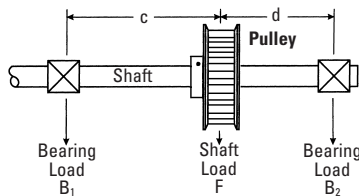

**Fig. 31 Overhung Pulley**

#### B. Pulley Between Bearings (See Figure 32)

$$B_1 = \frac{Fd}{(c + d)} \quad (14-5)$$

$$B_2 = \frac{Fc}{(c + d)} \quad (14-6)$$



**Fig. 32 Pulley Between Bearings**

## SECTION 15 HANDLING AND STORAGE

The following has been condensed from RMA Bulletin No. IP-3-4: "Storage of Power Transmission Belts": Recommendations for proper belt storage is of interest to designers as well as to users.

Under favorable storage conditions, high-quality belts maintain their performance capabilities and manufactured dimensions. Good storage conditions and practices will result in the best value from belt products.

Power transmission belts should ideally be stored in a cool and dry environment. Excess weight against belts resulting in distortion should be avoided. Avoid storing belts in environments that may allow exposure to sunlight, moisture, excessive heat, ozone, or where evaporating solvents or other chemicals are present. Belts have been found to be capable of withstanding storage, without changing significantly, for as long as 8 years at temperatures less than 85° F (30° C) and relative humidity below 70 percent without direct contact with sunlight.

Proper handling of synchronous belts is also important in preventing damage that could reduce their performance capabilities. Synchronous belts should never be crimped or tightly bent. Belts should not be bent tighter than the minimum recommended pulley size specified for each belt section, or pitch. Belt backside bending should be limited to the values specified in **Table 11** for a minimum diameter backside idler.

## SECTION 16 STANDARDS APPLICABLE TO BELTS

Different belt tooth configurations are shown in **Figure 19** and their characteristics are described in **Table 3**, both on page T-15. Since synchronous belts are manufactured by several manufacturers, each has established individual standards. Subsequently, the following general standards have been published:

1. Specifications by the Rubber Manufacturers Association for Drives using Synchronous Belts.
2. Synchronous Belt Drives – specification by the International Organization for Standardization.

Based on these, as well as standards developed by belt manufacturers, the following information is presented in this handbook:

Recommended Tension for Length Measurement.....	<b>Table 12</b>
Belt Width Tolerances.....	<b>Table 13</b>
Pitch Length Tolerances.....	<b>Table 14</b>
Center Distance Tolerances.....	<b>Table 15</b>
Overall Belt Thickness Dimensions.....	<b>Table 16</b>
Overall Belt Thickness Tolerances.....	<b>Table 17</b>

### Length Measurement

The pitch length of a synchronous belt is determined by placing the belt on a measuring fixture comprising two pulleys of equal diameter, applying tension and measuring the center distance between the two pulleys. One of the pulleys is fixed in position, while the other is movable along a graduated scale.

The fixture is shown schematically in **Figure 33**. Any pair of equal-diameter pulleys of the proper pitch and manufactured to specifications may be used for measuring. The measuring tension is given in **Table 11**.

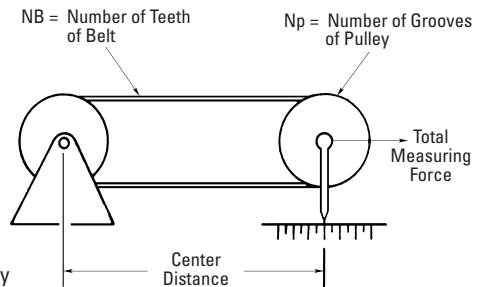

**Fig. 33 Length Measuring Fixture**

In measuring the length of a synchronous belt, the belt should be rotated at least two revolutions to seat it properly and to divide the tension equally between the two spans.

The pitch length is calculated by adding the pitch circumference of one pulley to twice the center distance:

$$\text{Belt Pitch Length} = 2C + (N_{\text{Pulley}} \times \text{Pitch})$$

$$C = \frac{\text{Pitch} (N_{\text{Belt}} - N_{\text{Pulley}})}{2}$$

where C is the Center Distance expressed in same units as the Pitch.

**Table 12 Recommended Tension for Length Measurement**

Total Measuring Tension			
Belt Width		Measuring Force	
in.	mm	lbf	N
0.25	6.4	8	36
0.31	7.9	10	44
0.37	9.5	12	53
0.50	12.7	24	105
0.75	19.1	40	180
1.00	25.4	55	245

**Table 13 Belt Width Tolerances**

Belt Selection	Standard Belt Width			Tolerance on Width for Belt Pitch Lengths					
	Designation	Dimensions		Up to and Including 838 mm (33 in.)		Over 838 mm (33 in.) Up to and Including 1676 mm (66 in.)		Over 1676 mm (66 in.)	
		mm	in.	mm	in.	mm	in.	mm	in.
MXL (0.080)	012	3.2	0.12	+0.5	0.020	+0.4	+0.016	—	—
	019	4.8	0.19	-0.8	0.031	-0.8	-0.031	—	—
	025	6.4	0.25						
XL (0.200)	025	6.4	0.25	+0.5	0.020	+0.8	+0.031	+0.031	+0.8
	037	9.7	0.38	-0.8	0.031	-1.2	-0.047	-0.047	-1.2
L (0.375)	050	12.7	0.50	+0.8	0.031	+0.03	+0.8	+1.2	+0.047
	075	19.1	0.75	-0.8	0.031	-0.05	-1.3	-1.6	-0.063
	100	25.4	1.00						

**Table 14 Pitch Length Tolerances**

Belt Pitch Length		Permissible Deviation from Standard		Belt Pitch Length		Permissible Deviation from Standard	
in.	mm	in.	mm	in.	mm	in.	mm
Up to 10	Up to 254	± 0.016	± 0.40	From 70 To 80	From 1778 To 2032	± 0.036	± 0.91
From 10 To 15	From 254 To 381	± 0.018	± 0.46	From 80 To 90	From 2032 To 2286	± 0.038	± 0.96
From 15 To 20	From 381 To 508	± 0.020	± 0.51	From 90 To 100	From 2286 To 2540	± 0.040	± 1.02
From 20 To 30	From 508 To 762	± 0.024	± 0.61	From 100 To 120	From 2540 To 3084	± 0.044	± 1.12
From 30 To 40	From 762 To 1016	± 0.026	± 0.66	From 120 To 140	From 3084 To 3556	± 0.048	± 1.22
From 40 To 50	From 1016 To 1270	± 0.030	± 0.76	From 140 To 160	From 3556 To 4064	± 0.052	± 1.32
From 50 To 60	From 1270 To 1524	± 0.032	± 0.81	From 160 To 170	From 4064 To 4318	± 0.054	± 1.37
From 60 To 70	From 1524 To 1778	± 0.034	± 0.86	From 170 To 180	From 4318 To 4572	± 0.058	± 1.47

**Table 15 Center Distance Tolerances**

Belt Length				Center Distance Tolerance	
inches		mm		inches	mm
Up to	10	Up to	254	± .008	± .20
Over	10	Over	254	± .009	± .23
To	15	To	381		
Over	15	Over	381	± .010	± .25
To	20	To	508		
Over	20	Over	508	± .012	± .30
To	30	To	762		
Over	30	Over	762	± .013	± .33
To	40	To	1016		
Over	40	Over	1016	± .015	± .38
To	50	To	1270		
Over	50	Over	1270	± .016	± .41
To	60	To	1524		
Over	60	Over	1524	± .017	± .43
To	70	To	1778		
Over	70	Over	1778	± .018	± .46
To	80	To	2032		
Over	80	Over	2032	± .019	± .48
To	90	To	2286		
Over	90	Over	2286	± .020	± .51
To	100	To	2540		
Over	100	Over	2540	± .021	± .53
To	110	To	2794		
Over	110	Over	2794	± .022	± .56
To	120	To	3048		

**Table 16 Overall Belt Thickness Dimensions**

Belt Type	Belt Pitch	Overall Thickness (ref.)	
		inches	mm
MXL	.080"	.045	1.14
40 D.P.	.0816"	.045	1.14
XL	.200"	.090	2.29
3 mm HTD	3 mm	.095	2.41
5 mm HTD	5 mm	.150	3.81
2 mm GT	2 mm	.060	1.52
3 mm GT	3 mm	.095	2.41
5 mm GT	5 mm	.150	3.81
T2.5	2.5 mm	.051	1.3
T5	5 mm	.087	2.2
T10	10 mm	.177	4.5

**Table 17 Overall Belt Thickness Tolerances**

Standard	Class 2	Class 1
± 0.015"	± 0.010"	± 0.005"
± 0.38 mm	± 0.25 mm	± 0.13 mm

**NOTE 1:** Belts with pitch lengths greater than 5.5" (140 mm) are furnished with a Class 2 grind unless otherwise specified. Belts with pitch lengths less than 5.5" (140 mm) are unground and produced to standard tolerances.

**NOTE 2:** A Class 1 grind is available at additional cost for finished belts only.

**SECTION 17 STANDARDS APPLICABLE TO PULLEYS AND FLANGES**

Pulleys are components manufactured to close tolerances in order to achieve best performance and long belt life. They are available in finished form or as bar stock which can be used for in-house manufacture of prototypes or smaller quantities.

For an uninitiated observer, a pulley may appear simply as a component with some trapezoidal or curvilinear grooves. In fact, the efficiency and integrity of a belt drive is closely attributed to the quality of pulleys involved. The pulleys, therefore, should be supplied by qualified and licensed suppliers. **In case of HTD and GT drives, the suppliers must be licensed by the Gates Rubber Company. Stock Drive Products is one of such licensed full line suppliers.**

To achieve the reproduction of the correct pulley profile, licensed hobs are used. The following inspection and design aids are used as well:

**Master Profile:** A scaled line drawing of the ideal groove profile with tolerance bands plotted on dimensionally stable translucent material. Suitable for groove inspection purposes on an optical comparator.

**Dimensional Profile Drawing:** A line drawing of the ideal groove profile with all arcs and radii defined. Suitable for mold design.

**Digitized Points:** A series of X and Y coordinates defining the ideal groove profile. Available in printed form. Suitable for mold design.

**Tolerancing/Inspection Procedure:** A typical pulley groove tolerance band is illustrated in **Figure 34**. Groove inspection must be made on an optical comparator at a specified magnification. The actual pulley groove profile must fit within the specified tolerance bands without any sharp transition or undercuts.

**17.1 Pulley Tolerances**

Stock Drive Products has accepted, as a minimum requirement, the Engineering Standards recommended by the Mechanical Power Transmission Association. The Rubber Manufacturers Association, Inc. (RMA), the Rubber Association of Canada and the Gates Rubber Company standards are approved by the Technical Committee of the above associations. These standards are in substantial compliance with standards developed by the International Organization for Standardization (ISO).

Requirements of some belt manufacturers exceed those of RMA and ISO. Whenever practicable, Stock Drive Products adheres to those specifications which are more stringent.

The following tables contain the applicable tolerances:

The following definitions are being used when considering quality of pulleys:

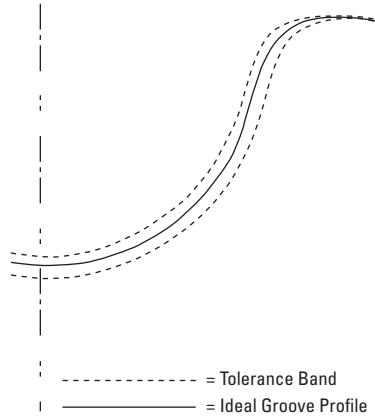

**Fig. 34 Typical Pulley Groove Tolerance Band**

**Table 18 Pulley O.D. Tolerances**

Pulley O.D.		Pulley O.D. Tolerances	
inches	mm	inches	mm
Up to 1	Up to 25.4	+0.02 -0.00	+0.05 -0.00
Over 1 To 2	Over 25.4 To 50.8	+0.03 -0.00	+0.08 -0.00
Over 2 To 4	Over 50.8 To 101.6	+0.04 -0.00	+0.10 -0.00
Over 4 To 7	Over 101.6 To 177.8	+0.05 -0.00	+0.13 -0.00
Over 7 To 12	Over 177.8 To 304.8	+0.06 -0.00	+0.15 -0.00
Over 12 To 20	Over 304.8 To 508.0	+0.07 -0.00	+0.18 -0.00
Over 20	Over 508.0	+0.08 -0.00	+0.20 -0.00

**Table 19 Pulley Eccentricity**

Outside Diameter		Total Eccentricity Total Indicator Reading	
inches	mm	inches	mm
Up to 2	Up to 50	0.0025	0.06
Over 2 To 4	Over 50 To 100	0.0030	0.08
Over 4 To 8	Over 100 To 200	0.0040	0.10
Over 8	Over 200	.0005"/inch O.D. > 8"	.013/mm O.D. > 200mm (may not exceed face diameter tolerance)

**Eccentricity:** The allowable amount of radial run out from the pulley bore to the O.D. is shown in **Table 19**.

**Helix Angle:** Grooves should be parallel to the axis of the bore within 0.001" per inch (0.025 mm per 25.4 mm) of pulley groove face width.

**Draft:** The maximum permissible draft on the groove form is 0.001" per inch (0.025 mm per 25.4 mm) of face width and must not exceed the O.D. tolerance.

**Parallelism:** The bore of the pulley is to be perpendicular to the vertical faces of the pulley within 0.001" per inch (0.025 mm per 25.4 mm) of diameter with a maximum of 0.020" (0.51 mm) total indicator reading.

**Pitch Accuracy:** Adequate pitch to pitch accuracy is generally more difficult to achieve with molded pulleys than with machined pulleys. Recommended tolerances are listed in **Table 21**.

**Balancing:** Balancing is often not required on machined metal pulleys. All pulleys should be statically balanced to 1/8 oz. (3.5 grams) in all sizes. Drives exceeding 6500 ft./min. (33m/s) may require special materials, and should be dynamically balanced to 1/4 ozf in. (1.78 Nmm).

Production pulleys should be made as closely to these tolerances as possible in order to maximize drive performance.

In addition to the **Tables 19, 20** and **21** which define the tolerances related to pulleys manufactured, **Tables 22** through **25** are given for reference only, as published by ISO (International Organization for Standardization) and RMA (Rubber Manufacturers Association).

**Table 20 Bore Tolerance for Pulleys**

Bore		Bore Tolerance	
in.	mm	in.	mm
To 1	To 25.4	+0.010 -0.000	+0.025 -0.000
1 to 2	25.4 to 50.8	+0.015 -0.000	+0.038 -0.000
2 to 3	50.8 to 76.2	+0.020 -0.000	+0.051 -0.000
3 up	76.2 up	+0.025 -0.000	+0.064 -0.000

**Table 21 Pulley Pitch Accuracy**

Bore		Pitch to Pitch		Accumulative *	
in.	mm	in.	mm	in.	mm
Up to 1.0	Up to 25.4	± .001	± 0.025	± .001	± 0.025
Over 1.0 To 2.0	Over 25.4 To 50.8	± .001	± 0.025	± .001	± 0.025
Over 2.0 To 4.0	Over 50.8 To 101.6	± .001	± 0.025	± .001	± 0.025
Over 4.0 To 7.0	Over 101.6 To 177.8	± .001	± 0.025	± .001	± 0.025
Over 7.0 To 12.0	Over 177.8 To 304.8	± .001	± 0.025	± .001	± 0.025
Over 12.0 To 20.0	Over 304.8 To 508.0	± .001	± 0.025	± .001	± 0.025
Over 20.0	Over 508.0	± .001	± 0.025	± .001	± 0.025

\* Over 90°

**Table 22 ISO Axial Pulley Runout**

Outside Diameter Range		Total Indicator Reading (max.)	
in.	mm	in.	mm
≤ 4.000	≤ 101.60	.004	0.10
> 4.000 ... ≤ 10.000	> 101.60 ... ≤ 254.00	.001/in. of O.D.	0.001/mm of O.D.
> 10.000	> 254.00	.010 + .0005/in. of O.D. over 10.000"	0.25 + 0.0005/mm of O.D. over 254.00 mm

**Table 23 ISO Radial Pulley Runout**

Outside Diameter Range		Total Indicator Reading (max.)	
in.	mm	in.	mm
≤ 8.000	≤ 203.20	.005	0.13
> 8.000	> 203.20	.005 + .0005/in. of O.D. over 8.000	0.13 + 0.0005/mm of O.D. over 203.20 mm

**Table 24 ISO Pulley O.D. Tolerances**

Outside Diameter		Tolerances	
in.	mm	in.	mm
≤ 1.000	≤ 25.40	+0.002 / -0.000	+0.05 / 0
> 1.000 ... ≤ 2.000	> 25.40 ... ≤ 50.80	+0.003 / -0.000	+0.08 / 0
> 2.000 ... ≤ 4.000	> 50.80 ... ≤ 101.60	+0.004 / -0.000	+0.10 / 0
> 4.000 ... ≤ 7.000	> 101.60 ... ≤ 177.80	+0.005 / -0.000	+0.13 / 0
> 7.000 ... ≤ 12.000	> 177.80 ... ≤ 304.80	+0.006 / -0.000	+0.15 / 0
> 12.000 ... ≤ 20.000	> 304.80 ... ≤ 508.00	+0.007 / -0.000	+0.18 / 0
> 20.000	> 508.00	+0.008 / -0.000	+0.20 / 0

**Table 25 RMA Pulley Bore Tolerances**

Length Diameter of Bore	Up thru .75 (19)	Over .75 (19) to and including 1.00 (25.4)	Over 1.00 (25.4) to and including 1.25 (31.8)	Over 1.25 (31.8) to and including 1.50 (38.1)	Over 1.50 (38.1) to and including 2.00 (50.8)	Over 2.00 (50.8) to and including 2.50 (63.5)	Over 2.50 (63.5) to and including 3.00 (76.2)
		Tolerances					
Up thru 0.50 (12.7)	+0.0015 +0.0005 (+0.038) (+0.013)	+0.0015 +0.0005 (+0.038) (+0.013)	+0.0015 +0.0005 (+0.038) (+0.013)	+0.0015 +0.0005 (+0.038) (+0.013)	+0.0015 +0.0005 (+0.038) (+0.013)		
Over 0.50 (12.7) to and including 1.00 (25.4)	+0.0015 +0.0005 (+0.038) (+0.013)	+0.0015 +0.0005 (+0.038) (+0.013)	+0.0015 +0.0005 (+0.038) (+0.013)	+0.0015 +0.0005 (+0.038) (+0.013)	+0.0020 +0.0005 (+0.051) (+0.013)	+0.0020 +0.0005 (+0.051) (+0.013)	+0.0020 +0.0005 (+0.051) (+0.013)
Over 1.00 (25.4) to and including 1.50 (38.1)		+0.0015 +0.0005 (+0.038) (+0.013)	+0.0015 +0.0005 (+0.038) (+0.013)	+0.0015 +0.0005 (+0.038) (+0.013)	+0.0020 +0.0010 (+0.051) (+0.025)	+0.0020 +0.0010 (+0.051) (+0.025)	+0.0020 +0.0010 (+0.051) (+0.025)
Over 1.50 (38.1) to and including 2.00 (50.8)			+0.0020 +0.0005 (+0.051) (+0.013)	+0.0020 +0.0005 (+0.051) (+0.013)	+0.0025 +0.0010 (+0.064) (+0.025)	+0.0025 +0.0010 (+0.064) (+0.025)	+0.0025 +0.0010 (+0.064) (+0.025)
Over 2.00 (50.8) to and including 2.50 (63.5)				+0.0020 +0.0005 (+0.051) (+0.013)	+0.0025 +0.0010 (+0.064) (+0.025)	+0.0025 +0.0010 (+0.064) (+0.025)	+0.0025 +0.0010 (+0.064) (+0.025)

**NOTE:** Dimensions in ( ) are in mm, all others are in inches.

## 17.2 Pulley Materials

There is a wide variety of materials and manufacturing processes available for the production of synchronous belt pulleys. In selecting an appropriate material and production process, the designer should consider dimensional accuracy, material strength, durability and production quantity. Some broad guidelines and recommendations are as follows:

### 1. Machining

Excellent dimensional accuracy. Economical for low to moderate production quantities.

#### Typical materials:

**Steel** – Excellent wear resistance.

**Aluminum** – Good wear resistance; pulleys for power transmission drives should be hard anodized.

### 2. Powdered Metal and Die Casting

Good dimensional accuracy. Economical for moderate to high production quantities.

#### Typical materials:

**Sintered Iron** – Excellent wear resistance.

**Sintered Aluminum** – Good wear resistance; lightweight and corrosion resistant.

**Zinc Die Cast** – Good wear resistance.

### 3. Plastic Molding

Good dimensional accuracy. Economical for high production quantities. Best suited for light to moderate torque loads. Fiber loading improves overall material strength and dimensional stability. However, increased belt wear can result from the presence of sharp abrasive fiber ends on the finished surface.

Assistance for total drive system design is available.  
Please contact our Application Engineering Department.

## 17.3 Flange Design And Face Width Guidelines

**Figure 35** illustrates the expressions used in flange and pulley design. **Tables 26** and **27** pertain to flange dimensions and pulley face widths respectively.

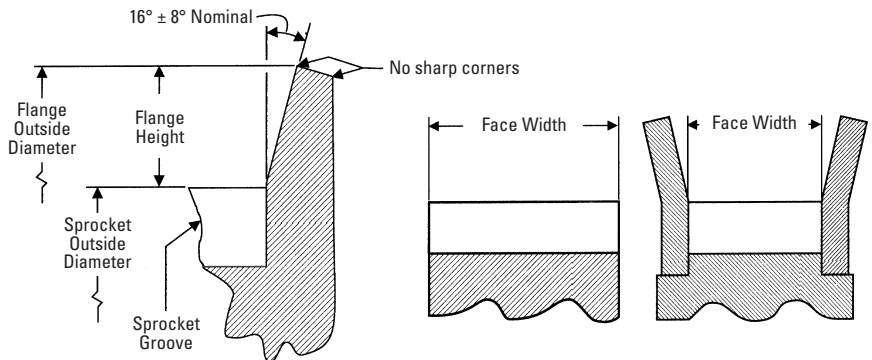

**Fig. 35 Expressions Used in Flange and Pulley Design**

**Table 26 Nominal Flange Dimensions for Molding, Sintering, Casting, etc.**

Belt Type	Minimum Flange Height		Nominal Flange Height	
	inches	mm	inches	mm
MXL	0.040	—	0.050	—
XL	0.060	—	0.080	—
2 mm GT®3	0.043	1.10	0.059	1.50
3 mm GT®3 & HTD®	0.067	1.70	0.098	2.50
5 mm GT®3 & HTD®	0.091	2.20	0.150	3.80

**Table 27 Additional Amount of Face Width Recommended over Nominal Belt Width \***

Belt Type	Nom. Face Width Unflanged		Nom. Face Width Flanged	
	inches	mm	inches	mm
MXL	+0.125	—	+0.040	—
XL	+0.190	—	+0.060	—
2 mm GT®3	+0.118	+3.00	+0.039	+1.00
3 mm GT®3 & HTD®	+0.157	+4.00	+0.049	+1.25
5 mm GT®3 & HTD®	+0.197	+5.00	+0.059	+1.50

\* Add Table Values to Nominal Belt Width for Nominal Face Width

**17.4 Guidelines For GT®3 Flange Design**

In some instances, special pulleys are used which are made from pulley stock. The following guidelines are given to establish the design parameters for flanges which would fit these special pulleys. If possible, standard available flanges should be used to avoid tooling charges associated with production of special sized flanges.

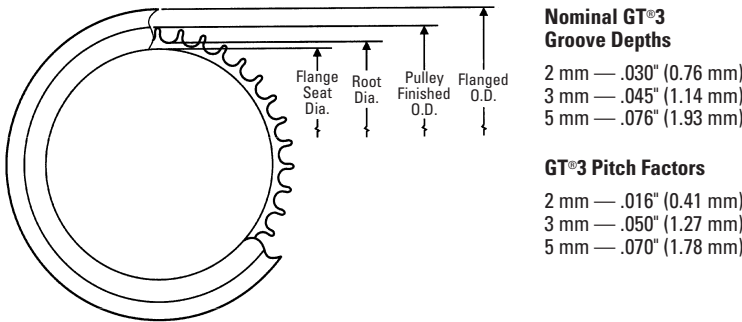

**Figure 36 Terms Used for Timing Pulley Flange Design**

**Steps:**

1. Determine pulley size and finished O.D.
2. Determine root diameter (Root Diameter = Finished O.D. – 2 x Nominal Groove Depth). See **Figure 19**, page T-15.
3. Determine maximum flange seat diameter. (Maximum Flange Seat Diameter = Root Diameter – Pitch Factor).
4. Select flange with inside diameter less than maximum flange seat diameter (see available flange sizes in the product section).
5. Determine flange seat diameter (Flange Seat Diameter = Flange I.D. +.000" –.003")
6. Determine flange seat width (Flange Seat Width = Flange Gauge + .020" ± .005"; see available flange sizes).
7. Flanges can be rolled, staked or punched on.

## SECTION 18 DOUBLE-SIDED BELT TOLERANCES

This type of belt was introduced briefly in **Section 5.1**, page T-10. As previously described, this type of belt has teeth on both sides to provide synchronization from both driving surfaces. This special feature makes possible unique drive designs, such as multipoint drives, rotation reversal with one belt, serpentine drives, etc. It may also provide solutions to other difficult design problems.

Double-Sided Belts are similar in construction to regular synchronous belts, including nylon-faced teeth on both sides. This construction uses essentially the same design parameters as standard synchronous belts. Their torque ratings are the same as conventional PowerGrip Belts of identical pitch and width.

Double-Sided Belts are available in MXL, XL, L, 3 and 5 mm HTD and T5 and T10 pitches from stock. See "Timing Belts and Pulleys Locator Charts" in the product section.

### Double-Sided Construction

Tensile members of the PowerGrip Double-Sided Belt are helically-wound fiberglass cords providing the same load-carrying capacity as single sided PowerGrip belts. The body is Neoprene rubber providing oil and weather resistance and protection for the fiberglass cords. Both sides of the belt have a specially treated nylon tooth facing that provides a tough wear-resistant surface with minimal friction.

### Double-Sided Tolerances

Since Double-Sided Belts are manufactured and cut to the required width by the same method as standard PowerGrip belts, the same manufacturing tolerances apply, except for the thickness and center distance tolerances listed in **Tables 28** and **29**.

Overall thickness, opposing teeth symmetry and pitch line symmetry are closely controlled during Double-Sided Belt manufacture.

### Specifying Double-Sided Belts

The available Double-Sided Belts and other double-sided belts from stock can be found from the Timing Belt Locator Chart, on page 2-2 of the product section.

### Double-Sided Drive Selection

Double-Sided Belts can transmit 100% of their maximum rated load from either side of the belt or in combination where the sum of the loads exerted on both sides does not exceed the maximum rating of the belt. For example, a Double-Sided Belt rated at 6 lbf in. could be used with 50% of the maximum rated on one side, and 50% on the other; or 90% on one side, and 10% on the other.



**Fig. 37 Double-Sided Belt Tolerances**

**Table 28 Belt Thickness Tolerances**

Belt	T (in.)	W (in.) Ref.
XL (.200")	.120 ± .007	.020
3 mm HTD	.126 ± .006	.030
5 mm HTD	.209 ± .007	.045
MXL	.060 ± .004	.020
L	.180 ± .012	.030
T5	.130 ± .010	.035
T10	.268 ± .014	.071

**Table 29 Center Distance Tolerances**

Belt Length (in.)	Center Distance Tolerances (in.)
15 to 20	± .020
20.01 to 30	± .024
30.01 to 40	± .026
40.01 to 50	± .030
50.01 to 60	± .032
60.01 to 70	± .034
over 70	To be specified

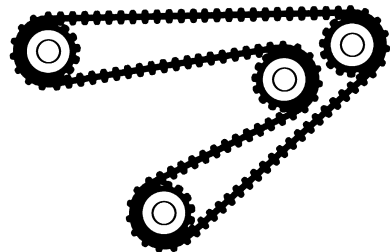

**Fig. 38 Double-Sided Belt Application**

Drive selection procedures for drives using Double-Sided Belts are much the same as for drives using conventional belting. Refer to the appropriate product and engineering sections in this catalog for drive torque ratings, engineering information, pulley details, belt tension recommendations, etc.

Some manufacturers, however, are producing double-sided belts which have nylon faced teeth on one side only. For those belts, the limitations given in **Section 5.1**, page **T-10** apply.

**SECTION 19 LONG LENGTH TIMING BELT STOCK SPECIFICATIONS**

Brief mention of this type of belt was given in **Section 5.2**, page **T-10**. As previously indicated, long length belt stock is produced in spiral form. Spiral cut belting is produced from a belt sleeve by moving the slitter laterally while the belt sleeve is rotating.

The resulting belting does not have continuous tensile cords, and the teeth are not perfectly perpendicular to the longitudinal axis of the belt. As a result, wider belts may cause performance problems (shown with \* in **Table 30**). As long as the belt width is narrow, these properties have been found to contribute little if any detrimental effects to belt performance. The maximum belt width available using this process is 1" (25 mm). Tensile modulus and strength are equivalent to conventional endless and long length belting.

This innovative product is available in all types of belting in all pitches. Reciprocating carriage drives requiring the use of higher performance curvilinear tooth belt products, in long length form, can now be easily handled.

This type of belt is called belt stock, and its availability from stock is indicated on the Timing Belt Locator Chart, on page **2-2**, at the beginning of the belt product section.

**Drive Selection With Neoprene Long-Length Belting**

Drive selection procedures for drives using Long-Length Belting are much the same as for drives using conventional endless belting. Refer to the appropriate product and engineering sections in this catalog for drive torque ratings, engineering information, pulley details, belt tension recommendations

etc. **Table 30** includes rated belt working tension data, for those applications for which it could be helpful, as well as maximum length available in each pitch. For drive design selection assistance with belt stock, contact our Application Engineering Department.

**Table 30 Neoprene Long-Length Belting Specifications**

Belt Type	Stock Width		Rated Working Tension, Ta		Maximum Available Length	
	in.	mm	lbf	N	ft.	m
MXL (.080")	.125	3	2.3	9	1000	305
	.1875	4.5	3.4	14	660	201
	.250	6	4.5	19	485	148
	.375	10	6.8	30	330	101
XL (.200")	.250	6	7.0	30	460	140
	.375	9.5	10.5	47	320	98
	.500	13	14.0	64	225	69
L (.375")	.500	13	24.5	112	275	83
	.750*	19*	36.8	163	185	56
	1.000*	25*	49.0	215	135	41
3 mm HTD®	.236	6	15.1	67	475	145
	.354	9	22.7	101	300	91
	.472	12	30.2	135	250	76
	.984*	25*	63.0	281	120	37
5 mm HTD®	.236	6	24.1	107	600	183
	.354	9	36.1	161	315	96
	.472	12	48.1	214	240	73
	.591	15	60.3	268	200	61
.984*	25*	100.4	447	115	35	
	2 mm GT®3	.236	6	5.9	26	600
.354		9	8.9	39	390	119
.472		12	11.8	52	300	91
3 mm GT®3	.236	6	26.9	120	600	183
	.354	9	40.4	180	385	117
	.472	12	53.8	240	300	91
5 mm GT®3	.354	9	56.6	252	360	110
	.472	12	75.5	336	275	83
	.591	15	94.6	420	230	70

I

R

**T**

1

2

3

4

5

6

7

8

9

10

11

12

13

14

15

A

**Center Distance Designer:** Provides computerized Drive Ratio and Center Distance calculations. The Center Distance Designer program, on the web, computes belt lengths for various center distances and checks the number of teeth in mesh for both pulleys. It calculates pulley drive ratios and the minimal center distance for a designated pulley pair.

The Center Distance Designer searches and retrieves all pulleys and belts shown in the handbook that fits within the customer criteria. Once the design is completed, the part numbers can be instantly retrieved from the database. Each part number is then linked to an electronic catalog page, which is viewable and can be printed.

## SECTION 21 DRIVE RATIO TABLES

In the design of belt drives, we usually know the speed ratio (transmission ratio) and we need to determine pulley sizes, center distance and belt length. These quantities are shown in **Figure 39**, for an open (uncrossed) belt.

The Drive Ratio Tables (**Table 31**, starting on page T-53) are designed to facilitate the determination of these quantities. They list the following information:

- N1/N2 = the transmission ratio obtained when the larger pulley (N1 teeth) is the input and smaller pulley (N2 teeth) is the output. Given to 3 decimal places.
- N2/N1 = the transmission ratio obtained when the larger pulley (N1 teeth) is the output and the smaller pulley (N2 teeth) is the input. Given to 3 decimal places.  
(Note that N1/N2 is the reciprocal of N2/N1)
- N1 = number of teeth on larger pulley.
- N2 = number of teeth on smaller pulley.
- N1 – N2 = difference between number of teeth on larger and smaller pulleys. This number is useful in center-distance determination.
- C MIN = The minimum center distance between pulleys for a belt of unit pitch. If the pitch is denoted by  $p$ , the actual minimum center distance is a product of C MIN and  $p$ . The minimum center distance is determined from the condition that at the minimum center distance, the pitch circles of the pulleys can be assumed to touch. This will generally give a satisfactory approximation to the practical minimum center distance. The table is based on the equation:

$$C \text{ MIN} = \frac{N1 + N2}{2\pi} \times \text{Belt Pitch} \quad (21-1)$$

At the beginning of the table, a list of standard pulley sizes is shown. The smallest pulley has 10 teeth and the largest, 156 teeth. A standard size will be the most economical. If a nonstandard size is needed, however, please contact Stock Drive Products for assistance.

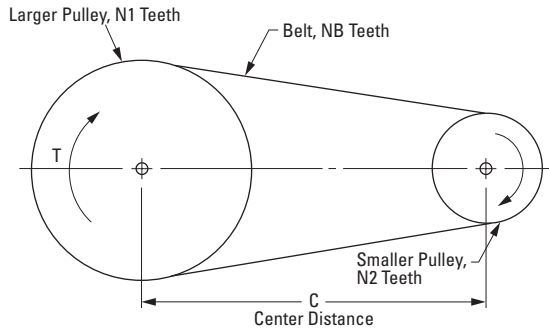

**Fig. 39 Belt Nomenclature**

The use of the tables is best illustrated by means of examples.

**Example 1:** For a transmission ratio of 1.067, find the number of teeth of the pulleys and the minimum center distance for a belt of 5 mm pitch.

When the transmission ratio is greater than unity, the larger pulley is the input and the smaller pulley is the output. That is to say, the transmission ratio is equal to  $N1/N2$ . The table is organized in order of increasing values of  $N1/N2$  and decreasing values of  $N2/N1$ . Referring to the table at this value of  $N1/N2$ , we find the following entries:

$N1/N2$	$N2/N1$	$N1$	$N2$	$N1 - N2$	$C \text{ MIN}$
1.067	0.938	16	15	1	4.934
		32	30	2	9.868

Hence, there are 2 different pulley combinations for the given transmission ratio of 1.067. For each of these, the minimum center distance is  $5 \times (C \text{ MIN})$  in mm. If the smaller pulley were driving, the transmission ratio would have been 0.938. The quantity  $(N1 - N2)$  is needed in center-distance calculations, as described in the next section.

**Example 2:** Given a transmission ratio of 0.680, determine the pulley sizes.

Since the transmission ratio is less than one, the smaller pulley is the input and the transmission ratio is given by  $N2/N1 = 0.680$ . Looking up this ratio in the table, we find  $N1 = 25$ ,  $N2 = 17$ ,  $N1 - N2 = 8$ . In this case, only one pulley combination is available.

**Example 3:** Given a driving pulley of 48 teeth and a driven pulley of 19 teeth, find the minimum center distance for a belt pitch of 3 mm.

The transmission ratio is  $N1/N2 = 48/19 = 2.526$ . Looking up this ratio in the table, we find  $C \text{ MIN} = 10.663$ . The minimum center distance, therefore, is given by  $3 \times 10.663$  or 31.989 mm.

**Example 4:** Given a transmission ratio of 2.258, find the pulley sizes.

Looking through the table, there is no entry at this value of the transmission ratio.

The nearest entries are:

$N1/N2$	$N2/N1$	$N1$	$N2$	$N1 - N2$
2.250	0.444	36	16	20
		72	32	40
2.273	0.440	25	11	14

Since the difference between the desired ratio and the nearest available ratios is only about 0.008, it is likely that the 2.250 or 2.273 ratios will be acceptable. If this is not the case, however, the design may require review, or a nonstandard pulley combination may be considered.

## DRIVE RATIO TABLES

**Table 31**

<p><b>Definition:</b></p> <p>Drive Ratio (Transmission Ratio) is the ratio of number of teeth of the input and output pulleys. If the input pulley is larger than the output, the Drive Ratio will be larger than one and we have a step-up drive. If the input pulley is smaller than the output pulley, the Drive Ratio will be smaller than one and we have a step-down drive.</p>	
<p><b>Nomenclature Used:</b></p> <p>N1 = Number of teeth of large pulley                  N2 = Number of teeth of small pulley                  N1/N2 = Step-up Drive Ratio                  N2/N1 = Step-down Drive Ratio                  N1 – N2 = Pulley tooth differential needed for <b>Table 42 – Center Distance Factor Table</b>                  C MIN = Minimum center distance for particular pulley combination expressed in belt pitches</p>	
<p><b>Pulley Sizes Included:</b></p> <p>10, 11, 12, 13, 14, 15, 16, 17, 18, 19, 20, 22, 24, 25, 28, 30, 32, 36, 40, 48, 60, 72, 84, 96, 120, 156</p>	
<p><b>Note:</b></p> <p>These pulley sizes reflect the preferred sizes per ISO Standard 5294 for synchronous belt drives – Pulleys (First edition – 1979-07-15). Many other sizes are offered in this catalog. The availability of stock sizes varies depending on the particular choice of pitch, material and configuration. Nonstandard sizes are available as custom made specials. Please submit your requirement for us to quote.</p>	

Continued on the next page

# TIMING BELTS, PULLEYS, CHAINS AND SPROCKETS

Table 31 (Cont.) Drive Ratio Tables

N1/N2	N2/N1	N1	N2	N1-N2	C MIN
1.000	1.000	10	10	0	3.183
		11	11	0	3.501
		12	12	0	3.820
		13	13	0	4.138
		14	14	0	4.456
		15	15	0	4.775
		16	16	0	5.093
		17	17	0	5.411
		18	18	0	5.730
		19	19	0	6.048
		20	20	0	6.366
		22	22	0	7.003
		24	24	0	7.639
		25	25	0	7.958
		28	28	0	8.913
		30	30	0	9.549
		32	32	0	10.186
36	36	0	11.459		
40	40	0	12.732		
48	48	0	15.279		
60	60	0	19.099		
72	72	0	22.918		
84	84	0	26.738		
96	96	0	30.558		
120	120	0	38.197		
156	156	0	49.656		
1.042	0.960	25	24	1	7.799
1.053	0.950	20	19	1	6.207
1.056	0.947	19	18	1	5.889
1.059	0.944	18	17	1	5.570
1.063	0.941	17	16	1	5.252
1.067	0.938	16	15	1	4.934
		32	30	2	9.868
1.071	0.933	15	14	1	4.615
		30	28	2	9.231
1.077	0.929	14	13	1	4.297
1.083	0.923	13	12	1	3.979
1.091	0.917	12	11	1	3.661
		24	22	2	7.321
1.100	0.909	11	10	1	3.342
		22	20	2	6.685
1.111	0.900	20	18	2	6.048
		40	36	4	12.096
1.118	0.895	19	17	2	5.730

Continued from the previous page

N1/N2	N2/N1	N1	N2	N1-N2	C MIN
1.120	0.893	28	25	3	8.435
1.125	0.889	18	16	2	5.411
		36	32	4	10.823
1.133	0.882	17	15	2	5.093
1.136	0.880	25	22	3	7.480
1.143	0.875	16	14	2	4.775
		32	28	4	9.549
		96	84	12	28.648
1.154	0.867	15	13	2	4.456
1.158	0.864	22	19	3	6.525
1.167	0.857	14	12	2	4.138
		28	24	4	8.276
		84	72	12	24.828
1.176	0.850	20	17	3	5.889
1.182	0.846	13	11	2	3.820
1.188	0.842	19	16	3	5.570
1.200	0.833	12	10	2	3.501
		18	15	3	5.252
		24	20	4	7.003
		30	25	5	8.754
		36	30	6	10.504
1.200	0.833	48	40	8	14.006
		72	60	12	21.008
		120	100	20	35.013
1.214	0.824	17	14	3	4.934
1.222	0.818	22	18	4	6.366
1.231	0.813	16	13	3	4.615
1.250	0.800	15	12	3	4.297
		20	16	4	5.730
		25	20	5	7.162
		30	24	6	8.594
		40	32	8	11.459
1.250	0.800	60	48	12	17.189
		120	96	24	34.377
		180	144	36	51.566
1.263	0.792	24	19	5	6.844
1.267	0.789	19	15	4	5.411
1.273	0.786	14	11	3	3.979
		28	22	6	7.958
1.280	0.781	32	25	7	9.072
1.286	0.778	18	14	4	5.093
		36	28	8	10.186
1.294	0.773	22	17	5	6.207
1.300	0.769	13	10	3	3.661
		156	120	36	43.927
1.308	0.765	17	13	4	4.775

Continued on the next page

**Table 31 (Cont.) Drive Ratio Tables**

N1/N2	N2/N1	N1	N2	N1-N2	C MIN
1.316	0.760	25	19	6	7.003
1.333	0.750	16	12	4	4.456
		20	15	5	5.570
		24	18	6	6.685
		32	24	8	8.913
		40	30	10	11.141
		48	36	12	13.369
		96	72	24	26.738
1.357	0.737	19	14	5	5.252
1.364	0.733	15	11	4	4.138
		30	22	8	8.276
1.375	0.727	22	16	6	6.048
1.385	0.722	18	13	5	4.934
1.389	0.720	25	18	7	6.844
1.400	0.714	14	10	4	3.820
		28	20	8	7.639
		84	60	24	22.918
1.412	0.708	24	17	7	6.525
1.417	0.706	17	12	5	4.615
1.429	0.700	20	14	6	5.411
		40	28	12	10.823
		120	84	36	32.468
1.440	0.694	36	25	11	9.708
1.455	0.688	16	11	5	4.297
		32	22	10	8.594
1.462	0.684	19	13	6	5.093
1.467	0.682	22	15	7	5.889
1.471	0.680	25	17	8	6.685
1.474	0.679	28	19	9	7.480
1.500	0.667	15	10	5	3.979
		18	12	6	4.775
		24	16	8	6.366
		30	20	10	7.958
		36	24	12	9.549
		48	32	16	12.732
		60	40	20	15.915
		72	48	24	19.099
1.538	0.650	20	13	7	5.252
1.545	0.647	17	11	6	4.456
1.556	0.643	28	18	10	7.321
1.563	0.640	25	16	9	6.525
1.571	0.636	22	14	8	5.730
1.579	0.633	30	19	11	7.799
1.583	0.632	19	12	7	4.934

Continued from the previous page

N1/N2	N2/N1	N1	N2	N1-N2	C MIN
1.600	0.625	16	10	6	4.138
		24	15	9	6.207
		32	20	12	8.276
		40	25	15	10.345
		48	30	18	12.414
		96	60	36	24.828
1.625	0.615	156	96	60	40.107
1.636	0.611	18	11	7	4.615
		36	22	14	9.231
1.647	0.607	28	17	11	7.162
1.667	0.600	20	12	8	5.093
		25	15	10	6.366
		30	18	12	7.639
		40	24	16	10.186
		60	36	24	15.279
		120	72	48	30.558
1.684	0.594	32	19	13	8.117
1.692	0.591	22	13	9	5.570
1.700	0.588	17	10	7	4.297
1.714	0.583	24	14	10	6.048
		48	28	20	12.096
1.727	0.579	19	11	8	4.775
1.750	0.571	28	16	12	7.003
		84	48	36	21.008
1.765	0.567	30	17	13	7.480
1.778	0.563	32	18	14	7.958
1.786	0.560	25	14	11	6.207
1.800	0.556	18	10	8	4.456
		36	20	16	8.913
		72	40	32	17.825
1.818	0.550	20	11	9	4.934
		40	22	18	9.868
1.833	0.545	22	12	10	5.411
1.846	0.542	24	13	11	5.889
1.857	0.538	156	84	72	38.197
1.867	0.536	28	15	13	6.844
1.875	0.533	30	16	14	7.321
		60	32	28	14.642
1.882	0.531	32	17	15	7.799
1.895	0.528	36	19	17	8.754
1.900	0.526	19	10	9	4.615
1.920	0.521	48	25	23	11.618
1.923	0.520	25	13	12	6.048
2.000	0.500	20	10	10	4.775

Continued on the next page

# TIMING BELTS, PULLEYS, CHAINS AND SPROCKETS

**Table 31 (Cont.) Drive Ratio Tables**

N1/N2	N2/N1	N1	N2	N1-N2	C MIN
2.000	0.500	22	11	11	5.252
		24	12	12	5.730
		28	14	14	6.685
		30	15	15	7.162
		32	16	16	7.639
		36	18	18	8.594
		40	20	20	9.549
		48	24	24	11.459
		60	30	30	14.324
		72	36	36	17.189
		96	48	48	22.918
		120	60	60	28.648
2.083	0.480	25	12	13	5.889
2.100	0.476	84	40	44	19.735
2.105	0.475	40	19	21	9.390
2.118	0.472	36	17	19	8.435
2.133	0.469	32	15	17	7.480
2.143	0.467	30	14	16	7.003
2.143	0.467	60	28	32	14.006
2.154	0.464	28	13	15	6.525
2.167	0.462	156	72	84	36.287
2.182	0.458	24	11	13	5.570
		48	22	26	11.141
2.200	0.455	22	10	12	5.093
2.222	0.450	40	18	22	9.231
2.250	0.444	36	16	20	8.276
		72	32	40	16.552
2.273	0.440	25	11	14	5.730
2.286	0.438	32	14	18	7.321
2.308	0.433	30	13	17	6.844
2.333	0.429	28	12	16	6.366
		84	36	48	19.099
2.353	0.425	40	17	23	9.072
2.400	0.417	24	10	14	5.411
		36	15	21	8.117
		48	20	28	10.823
		60	25	35	13.528
		72	30	42	16.234
		96	40	56	21.645
2.462	0.406	32	13	19	7.162
2.500	0.400	25	10	15	5.570
		30	12	18	6.685
		40	16	24	8.913
		60	24	36	13.369

Continued from the previous page

N1/N2	N2/N1	N1	N2	N1-N2	C MIN
2.500	0.400	120	48	72	26.738
2.526	0.396	48	19	29	10.663
2.545	0.393	28	11	17	6.207
2.571	0.389	36	14	22	7.958
		72	28	44	15.915
2.600	0.385	156	60	96	34.377
2.625	0.381	84	32	52	18.462
2.667	0.375	32	12	20	7.003
		40	15	25	8.754
		48	18	30	10.504
		96	36	60	21.008
2.727	0.367	30	11	19	6.525
		60	22	38	13.051
2.769	0.361	36	13	23	7.799
2.800	0.357	28	10	18	6.048
		84	30	54	18.144
2.824	0.354	48	17	31	10.345
2.857	0.350	40	14	26	8.594
2.880	0.347	72	25	47	15.438
2.909	0.344	32	11	21	6.844
3.000	0.333	30	10	20	6.366
		36	12	24	7.639
		48	16	32	10.186
		60	20	40	12.732
		72	24	48	15.279
		84	28	56	17.825
3.077	0.325	96	32	64	20.372
		120	40	80	25.465
3.077	0.325	40	13	27	8.435
3.158	0.317	60	19	41	12.573
3.200	0.313	32	10	22	6.685
		48	15	33	10.027
		96	30	66	20.054
3.250	0.308	156	48	108	32.468
		36	11	25	7.480
3.273	0.306	72	22	50	14.961
3.333	0.300	40	12	28	8.276
		60	18	42	12.414
		120	36	84	24.828
3.360	0.298	84	25	59	17.348
3.429	0.292	48	14	34	9.868
		96	28	68	19.735
3.500	0.286	84	24	60	17.189
3.529	0.283	60	17	43	12.255

Continued on the next page

**Table 31 (Cont.) Drive Ratio Tables**

N1/N2	N2/N1	N1	N2	N1-N2	C MIN	N1/N2	N2/N1	N1	N2	N1-N2	C MIN
3.600	0.278	36	10	26	7.321	5.600	0.179	84	15	69	15.756
		72	20	52	14.642	5.647	0.177	96	17	79	17.985
3.636	0.275	40	11	29	8.117	6.000	0.167	60	10	50	11.141
3.692	0.271	48	13	35	9.708			72	12	60	13.369
3.750	0.267	60	16	44	12.096			84	14	70	15.597
		120	32	88	24.192			96	16	80	17.825
3.789	0.264	72	19	53	14.483			120	20	100	22.282
3.818	0.262	84	22	62	16.870	6.240	0.160	156	25	131	28.807
3.840	0.260	96	25	71	19.258	6.316	0.158	120	19	101	22.123
3.900	0.256	156	40	116	31.194	6.400	0.156	96	15	81	17.666
		4.000	0.250	40	10	30	7.958	6.462	0.155	84	13
48	12			36	9.549	6.500	0.154	156	24	132	28.648
60	15			45	11.937	6.545	0.153	72	11	61	13.210
72	18			54	14.324	6.667	0.150	120	18	102	21.963
96	24			72	19.099	6.857	0.146	96	14	82	17.507
120	30	90	23.873	7.000	0.143	84	12	72	15.279		
4.200	0.238	84	20	64	16.552	7.059	0.142	120	17	103	21.804
4.235	0.236	72	17	55	14.165	7.091	0.141	156	22	134	28.330
4.286	0.233	60	14	46	11.777	7.200	0.139	72	10	62	13.051
		120	28	92	23.555	7.385	0.135	96	13	83	17.348
4.333	0.231	156	36	120	30.558	7.500	0.133	120	16	104	21.645
4.364	0.229	48	11	37	9.390	7.636	0.131	84	11	73	15.120
		96	22	74	18.780	7.800	0.128	156	20	136	28.011
4.421	0.226	84	19	65	16.393	8.000	0.125	96	12	84	17.189
4.500	0.222	72	16	56	14.006			120	15	105	21.486
4.615	0.217	60	13	47	11.618	8.211	0.122	156	19	137	27.852
4.667	0.214	84	18	66	16.234	8.400	0.119	84	10	74	14.961
		4.800	0.208	48	10	38	9.231	8.571	0.117	120	14
72	15			57	13.846	8.667	0.115	156	18	138	27.693
96	20			76	18.462	8.727	0.115	96	11	85	17.030
120	25			95	23.077	9.176	0.109	156	17	139	27.534
4.875	0.205			156	32	124	29.921	9.231	0.108	120	13
4.941	0.202	84	17	67	16.075	9.600	0.104	96	10	86	16.870
5.000	0.200	60	12	48	11.459	9.750	0.103	156	16	140	27.375
		120	24	96	22.918	10.000	0.100	120	12	108	21.008
5.053	0.198	96	19	77	18.303	10.400	0.096	156	15	141	27.215
5.143	0.194	72	14	58	13.687	10.909	0.092	120	11	109	20.849
5.200	0.192	156	30	126	29.603	11.143	0.090	156	14	142	27.056
5.250	0.190	84	16	68	15.915	12.000	0.083	120	10	110	20.690
5.333	0.188	96	18	78	18.144			156	13	143	26.897
5.455	0.183	60	11	49	11.300	13.000	0.077	156	12	144	26.738
		120	22	98	22.600	14.182	0.071	156	11	145	26.579
5.538	0.181	72	13	59	13.528	15.600	0.064	156	10	146	26.420
5.571	0.179	156	28	128	29.285						

Continued from the previous page

## SECTION 22 CENTER DISTANCE FORMULAS FOR PULLEYS AND SPROCKETS

### 22.1 Nomenclature And Basic Equations

**Figure 40** illustrates the notation involved. The following nomenclature is used:

- C = Center Distance (in)
- L = Belt Length or Chain (in) =  $p \cdot NB$
- p = Pitch of Belt or Chain (in)
- NB = Number of Teeth on belt or rollers on chain =  $L/p$
- N1 = Number of Teeth (grooves) on larger pulley or sprocket
- N2 = Number of Teeth (grooves) on smaller pulley or sprocket
- $\phi$  = One half angle of wrap on smaller pulley (radians) or sprocket
- $\theta = \pi/2 - \phi$  = angle between straight portion of belt or chain and line of centers (radians)
- R1 = Pitch Radius of larger pulley or sprocket (in) =  $(N1) p/2\pi$
- R2 = Pitch Radius of smaller pulley or sprocket (in) =  $(N2) p/2\pi$
- $\pi = 3.14159$  (ratio of circumference to diameter of circle)

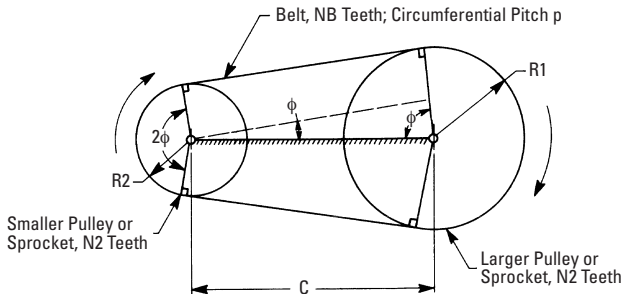

**Figure 40 Belt Geometry**

The basic equation for the determination of center distance is:

$$2C \sin\phi = L - \pi(R1 + R2) - (\pi - 2\phi)(R1 - R2) \tag{22-1}$$

where  $C \cos\phi = R1 - R2$  (22-2)

These equations can be combined in different ways to yield various equations for the determination of center distance. We have found the formulations, which follow, useful.

### 22.2 Exact Center Distance Determination – Unequal Pulleys or Sprockets

The exact equation is as follows:

$$C = (1/2)p [(NB - N1) + k(N1 - N2)] \tag{22-3}$$

where  $k = \left(\frac{1}{\pi}\right) \left[\tan\left(\frac{\pi}{4} - \frac{\phi}{2}\right) + \phi\right]$  (22-4)

and  $\phi$  is determined from:

$$\left(\frac{1}{\pi}\right) (\tan\phi - \phi) = \frac{(NB - N1)}{(N1 - N2)} = Q \tag{22-5}$$

The value,  $C/p$ , is called the center distance factor and is tabulated for various combinations of  $(NB - N1)$  and  $(N1 - N2)$  in **Table 42** in the next section.

The value of  $k$  varies within the range  $(1/\pi, 1/2)$  depending on the number of teeth on the belt or rollers on the chain. All angles in **Equations (22-4)** through **(22-5)** are in radians.

The procedure for center distance determination is as follows:

1. Select values of  $N1, N2$  (in accordance with desired transmission ratio) and  $NB$ .
2. Compute  $Q = (NB - N1)/(N1 - N2)$ .
3. Compute  $\phi$  by solving **Equation (22-5)** numerically.
4. Compute  $k$  from **Equation (22-4)**.
5. Compute  $C$  from **Equation (22-3)**.

### 22.3 Exact Center Distance Determination – Equal Pulleys or Sprockets

For equal pulleys,  $N1 = N2$  and **Equation (22-3)** becomes:

$$C = \frac{p(NB - N1)}{2} \quad (22-6)$$

### 22.4 Approximate Center Distance Determination

Approximate formulas are used when it is desirable to minimize computation time and when an approximate determination of center distance suffices.

An alternative to **Equation (22-1)** for the exact center distance can be shown to be the following:

$$C = \frac{p}{4} \left\{ NB - \frac{(N1 + N2)}{2} + \sqrt{\left[ NB - \frac{(N1 + N2)}{2} \right]^2 - \frac{2(N1 - N2)^2}{\pi^2} (1 + S)} \right\} \quad (22-7)$$

where  $S$  varies between 0 and 0.1416, depending on the angle of wrap of the smaller pulley. The value of  $S$  is given very nearly by the expression:

$$S = \frac{(\cos^2 \phi)}{12} \quad (22-8)$$

In the approximate formulas for center distance, it is customary to neglect  $S$  and thus to obtain following approximation for  $C$ :

$$C = \frac{p}{4} \left\{ NB - \frac{(N1 + N2)}{2} + \sqrt{\left[ NB - \frac{(N1 + N2)}{2} \right]^2 - \frac{2(N1 - N2)^2}{\pi^2}} \right\} \quad (22-9)$$

The error in **Equation (22-9)** depends on the speed ratio and the center distance. The accuracy is greatest for speed ratios close to unity and for large center distances. The accuracy is least at minimum center distance and high transmission ratios. In many cases, the accuracy of the approximate formula is acceptable.

Alternatively, center distance can be obtained to sufficient accuracy using the center distance factor table (See **Section 23**).

### 22.5 Number Of Teeth In Mesh (TIM)

It is generally recommended that the number of teeth in mesh be not less than 6. The number,  $TIM$ , teeth in mesh is given by:

$$TIM = \lambda \cdot N2 \tag{22-10}$$

where  $\lambda = \frac{\phi}{\pi}$  when  $\phi$  [see **Equation (22-5)**] is given in radians (see also the derivation given for TIM in this Handbook).

**22.6 Determination Of Belt Or Chain Size For Given Pulleys And Center Distance**

Occasionally, the center distance of a given installation is prescribed and the belt length is to be determined. For given pitch, number of teeth on pulleys and center distance, the number of teeth of the belt can be found from the equation:

$$NB = \frac{(N1 + N2)}{2} + \frac{(N1 - N2)}{\pi} \sin^{-1} \left[ \frac{(N1 - N2)p}{2\pi C} \right] + \sqrt{\left(\frac{2C}{p}\right)^2 - \left(\frac{N1 - N2}{\pi}\right)^2} \tag{22-11}$$

where the arcsin is given in radians and lies between 0 and  $\pi/2$ . Since NB, in general, will not be a whole number, the nearest whole number less than NB can be used, assuming a slight increase in belt tension is not objectionable.

An approximate formula can be used to obtain the belt length:

$$L = 2C + \frac{(D1 - D2)^2}{4C} + 1.57 \times (D1 + D2) \tag{22-12}$$

**SECTION 23 CENTER DISTANCE FACTOR TABLES (TABLE 32)**

**SECTION 24 TIMING BELT DRIVE SELECTION PROCEDURE****Step 1 Determination of design load**

Drives consist of a driver and a driven pulley. In general, both pulleys are not of the same size; therefore, a speed reduction or increase occurs. Both convey the same power; however, the torque on each pulley is different. Drive designs should be based on the smaller pulley which will be subject to higher speed.

The peak design load must be taken into account, and it is obtained by multiplying the torque by a service factor. Service factors between 1.5 and 2.0 are generally recommended when designing small pitch synchronous drives. Knowledge of drive loading characteristics should influence the actual value selected. A higher service factor should be selected for applications with high peak loads, high operating speeds, unusually severe operating conditions, etc. Lower service factors can be used when the loading is smooth, well defined, etc. and the reliability is less critical. Some designs may require service factors outside the 1.5 to 2.0 range, depending upon the nature of the application.

If a stall torque of the driver is not given but the nameplate horsepower or kW power consumption is known, the torque can be obtained from:

$$T (\text{lbf in.}) = \frac{63.025 \times \text{Shaft hp in.}}{\text{Shaft rpm}} \quad (24-1)$$

$$T (\text{lbf in.}) = 8.85 \times T (\text{Nm}) \quad \text{or} \quad (24-2)$$

$$T (\text{ozf in.}) = 16 \times T (\text{lbf in.}) \quad (24-3)$$

$$T_{\text{peak}} = T \times \text{Service Factor} \quad (24-4)$$

$$1 \text{ kW} = 1.341 \text{ hp} \quad (24-5)$$

**Step 2 Choice of belt pitch**

As shown in **Figure 4**, (page T-6) different belt pitches can satisfy the same horsepower requirements, also taking into account the speed of the faster shaft. The choice is somewhat individual and may take into account, among others, the following factors:

- compatibility with previous designs
- superiority of GT drives as far as noise, backlash, positioning accuracy, etc. is concerned
- local availability for replacement
- size limitations; i.e. the size of pulleys and of the entire drive will be optimized if GT3 or HTD pitches are used

**Step 3 Check belt pitch selection based on individual graphs**

Graphs shown on **Figures 41** through **43** show the peak torque,  $T_{\text{peak}}$  computed previously, plotted against the speed of faster shaft. Since the belt pitch was chosen in **Step 2**, reference to these graphs will confirm the validity of the selection.

As an example, assume that the following data was obtained:  $T_{\text{peak}} = 5 \text{ lbf in.}$  and 1000 rpm. The potential choices are: 2 mm GT3, 3 mm HTD, or XL. The 2 mm drive will be substantially smaller than the other choices.

**Step 4 Determine speed ratio**

Use Drive Ratio Tables shown in **SECTION 21**, starting at page T-51, and establish the number of teeth of the small and large pulley based on the chosen speed ratio. Attempt to use available stock sizes for best economy. Use of our website will immediately guide you to the appropriate catalog page and part number. Make note of the Pitch Diameter (*PD*) of the small pulley.

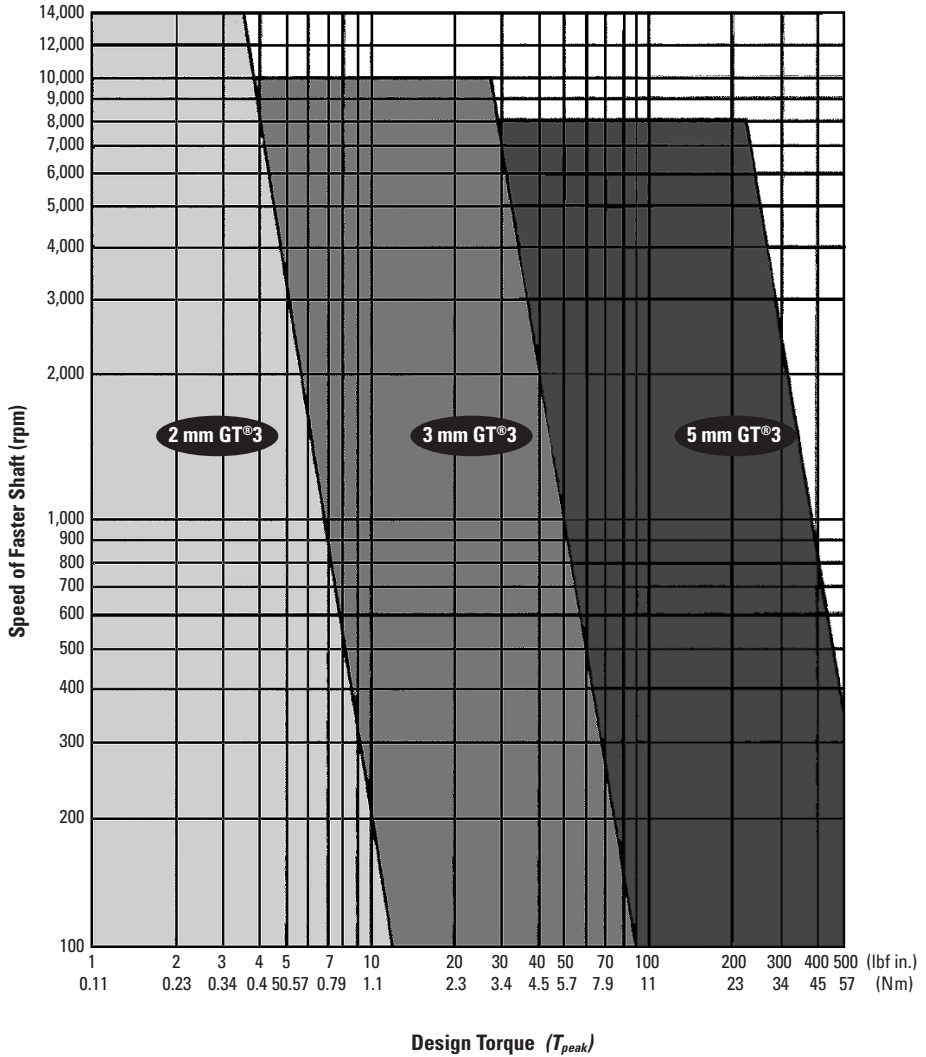

Fig. 41 GT³ Belt Selection Guide

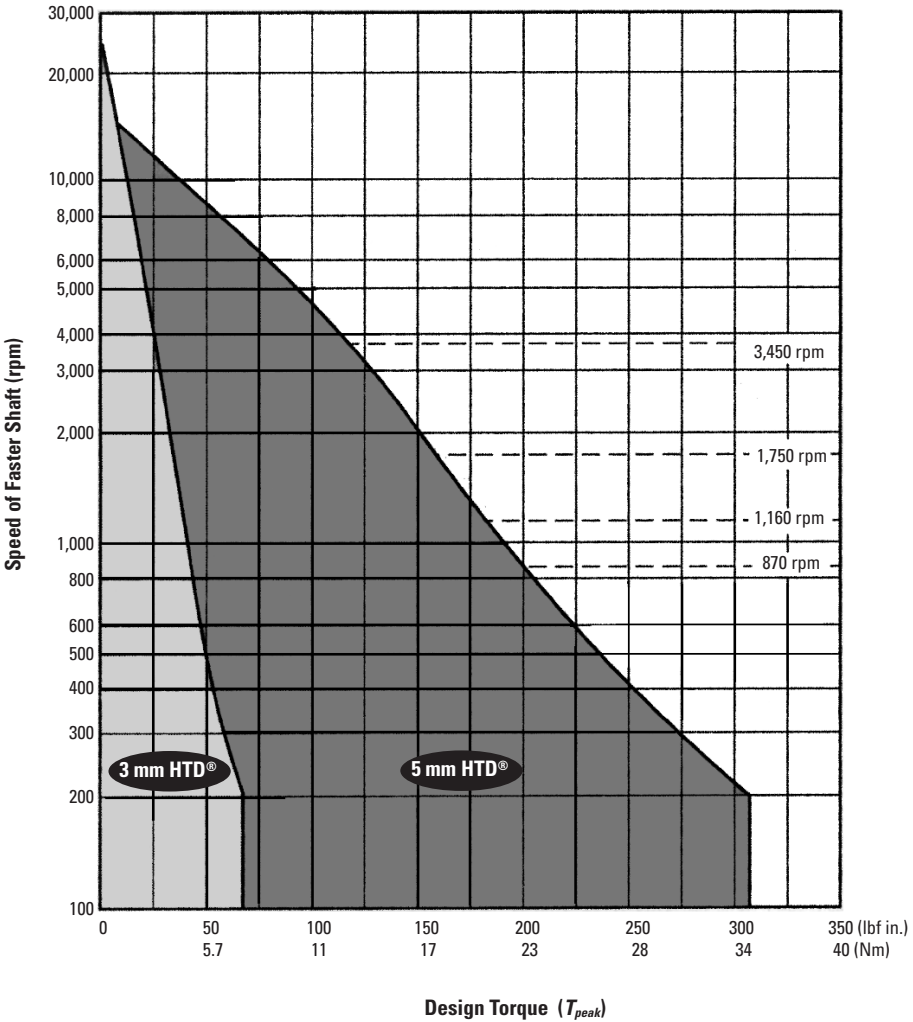
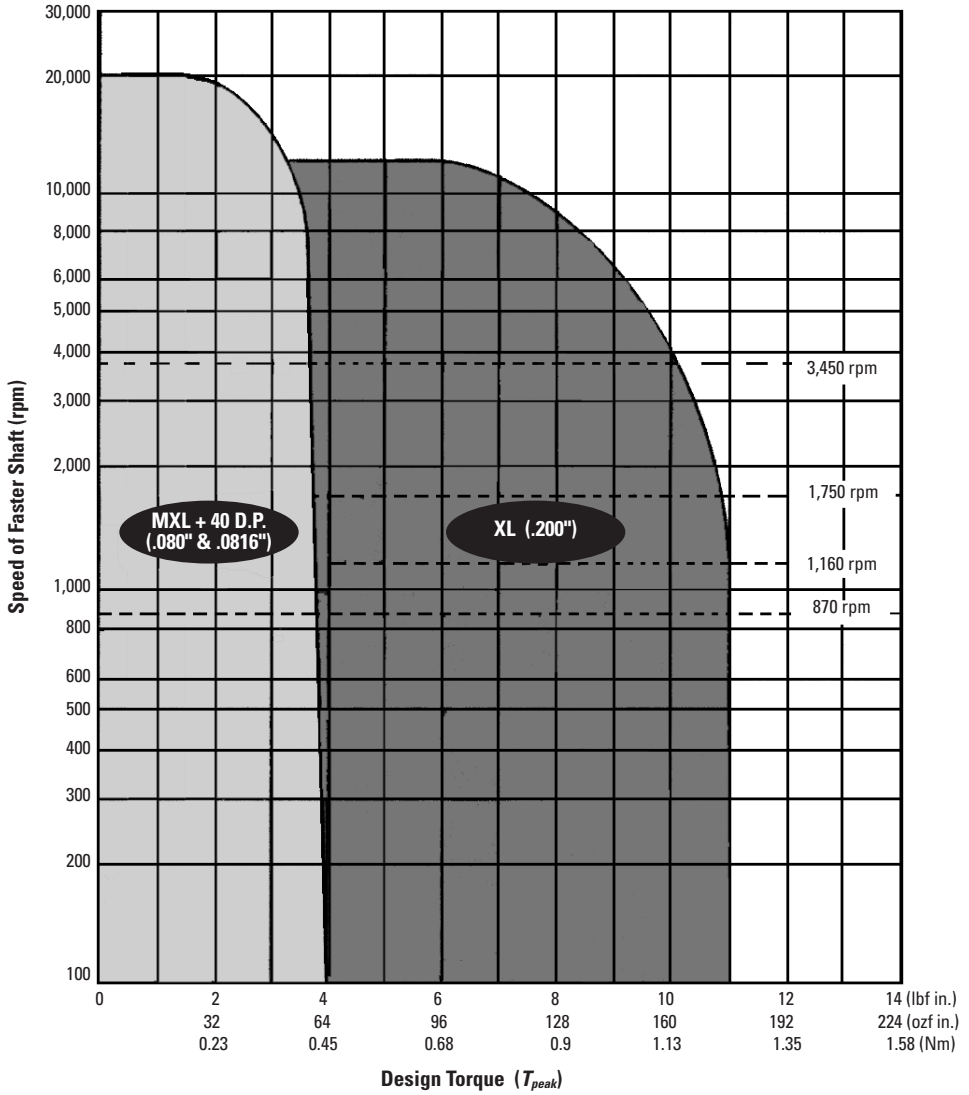

Fig. 42 HTD® Belt Selection Guide



**Fig. 43 Trapezoidal Belt Selection Guide**

**Step 5 Check belt speed**

Belt speeds up to 6,500 fpm (33.02 m/s) do not require special pulleys. Speeds higher than these require special pulley materials and dynamic balancing.

Speed is computed using the following equations:

$$V(\text{fpm}) = 0.262 \times \text{pulley } PD (\text{in.}) \times \text{pulley rpm} \quad (24-5)$$

$$V(\text{m/s}) = 0.0000524 \times \text{pulley } PD (\text{mm}) \times \text{pulley rpm} \quad (24-6)$$

where:  $\text{m/s} = 0.00508 \times \text{fpm} \quad (24-7)$

**Step 6 Determine belt length**

The design layout may govern the determination of the belt length. Since the pulley sizes are known, use of Center Distance Factor Tables shown in **SECTION 23** (starting on page T-60) will yield NB – the number of teeth of the belt. If a fractional number is obtained, the closest integer number should be chosen, and the calculation must be repeated to obtain the new center distance for the design.

It is worthwhile to check if a belt with the chosen number of teeth is available in this Handbook. If it is not available, the closest fitting belt size must be chosen, and the calculation must be repeated to establish the center distance to which the layout must be corrected to accommodate the available choice of belt.

**Step 7 Determine the belt width**

The number of grooves of the small pulley as well as the rpm of the faster shaft on which this pulley is located are known. **Tables 33** through **42** show the torque and/or horsepower or kilowatt ratings for the base width of particular belt pitches.

For the HTD and GT3 drives, the torque ratings shown in these tables must be multiplied by the length correction factor. This factor is a number smaller than 1 for shorter length and higher for longer belts. This reflects the fact that a longer belt will be less prone to wear and tear as opposed to a shorter belt.

When the given torque from the table is multiplied by the length correction factor, this figure may be smaller or larger than the previously computed peak torque  $T_{peak}$ . If it is smaller, a belt narrower than the base width can be used. Alternatively, if  $T_{peak}$  is larger, a wider belt must be specified. In order to finalize the belt width, the width multiplier given on the particular table itself must be used. Also, consult the appropriate belt product page for availability of standard widths. We are able to supply nonstandard width belts as well as nonstandard width pulleys, if desired.

In any event, the torque ratings given in the table multiplied by the length factor and by the width multiplier must yield a torque greater than the  $T_{peak}$  computed previously.

The torque or horsepower ratings are based on 6 or more teeth in mesh for the smaller pulley.

## Step 8 Check the number of teeth in mesh

The arc of contact on the smaller pulley in degrees can be found as follows:

$$\text{Arc of Contact} = 180 - \left( \frac{60 (PD - pd)}{C} \right) \quad (\text{degrees}) \quad (24-8)$$

where:  $PD$  = Large pitch diameter, inches  
 $pd$  = Small pitch diameter, inches  
 $C$  = Drive center distance, inches

The number of teeth in mesh on the smaller pulley can be found as follows:

$$\text{Teeth in Mesh} = \frac{(Arc) (n)}{360} \quad (24-9)$$

where:  $Arc$  = Arc of contact; small pulley, degrees  
 $n$  = number of grooves, small pulley

Drop any fractional part and use only the whole number as any tooth not fully engaged cannot be considered a working tooth.

If the teeth in mesh is less than 6, correct the belt torque rating with the following multiplication factors:

- 5 teeth in mesh ..... multiply by 0.8
- 4 teeth in mesh ..... multiply by 0.6
- 3 teeth in mesh ..... multiply by 0.4
- 2 teeth in mesh ..... suggest redesign
- 1 tooth in mesh ..... suggest redesign

## Step 9 Determine proper belt installation tension

Procedure to calculate proper belt installation tension for specific applications are included in **SECTION 10**, on page T-29.

# TIMING BELTS, PULLEYS, CHAINS AND SPROCKETS

**Table 33 Rated Torque (lbf in.) for Small Pulleys - 6 mm Belt Width**

The following table represents the torque ratings for each belt, in its base width, at the predetermined number of grooves, pitch diameters and rpm's. These ratings must be multiplied by the appropriate width factor and applicable belt length factor to obtain the corrected torque rating (see **Step 7 of SECTION 24**, on page T-65).

## 2 mm Pitch PowerGrip® GT®3 Belts

<b>Belt Width (mm)</b>	<b>4</b>	<b>6</b>	<b>9</b>	<b>12</b>
<b>Width Multiplier</b>	0.67	1.00	1.50	2.00

Number of Grooves	12	14	16	18	20	24	28	32	36	40	48	56	64	72	80
	mm 0.301	8.91 0.351	10.19 0.401	11.46 0.451	12.73 0.501	15.28 0.602	17.83 0.702	20.37 0.802	22.92 0.902	25.46 1.003	30.56 1.203	35.65 1.404	40.74 1.604	45.84 1.805	50.93 2.005
Pitch Diameter	10	0.90	1.09	1.27	1.45	1.63	1.89	2.15	2.35	2.71	3.07	3.43	3.84	4.13	4.84
	20	0.89	1.07	1.25	1.42	1.60	1.96	2.31	2.66	3.01	3.37	3.76	4.13	4.45	5.15
	40	0.87	1.05	1.22	1.40	1.57	1.92	2.27	2.62	2.96	3.31	3.69	4.06	4.38	5.08
	60	0.86	1.03	1.21	1.38	1.55	1.90	2.25	2.59	2.93	3.27	3.65	3.99	4.31	5.01
	100	0.85	1.02	1.19	1.36	1.53	1.88	2.22	2.55	2.89	3.23	3.60	3.94	4.25	4.95
	200	0.83	1.00	1.17	1.34	1.50	1.84	2.17	2.51	2.84	3.17	3.53	3.87	4.18	4.88
rpm of Fastest Shaft	300	0.82	0.99	1.15	1.32	1.49	1.82	2.15	2.48	2.81	3.14	3.49	3.80	4.50	5.20
	400	0.81	0.98	1.14	1.31	1.47	1.81	2.13	2.46	2.78	3.11	3.46	3.76	4.46	5.16
	500	0.80	0.97	1.14	1.30	1.46	1.79	2.12	2.44	2.77	3.09	3.43	3.73	4.43	5.13
	600	0.80	0.97	1.13	1.29	1.46	1.78	2.11	2.43	2.75	3.08	3.42	3.72	4.42	5.12
	800	0.79	0.96	1.12	1.28	1.44	1.77	2.09	2.41	2.73	3.05	3.39	3.69	4.39	5.09
	1000	0.79	0.95	1.11	1.27	1.43	1.76	2.08	2.40	2.71	3.03	3.36	3.66	4.36	5.06
[Tabulated values are in lbf in.]	1200	0.78	0.94	1.11	1.27	1.43	1.75	2.07	2.38	2.70	3.02	3.34	4.04	4.74	5.44
	1400	0.78	0.94	1.10	1.26	1.42	1.74	2.06	2.37	2.69	3.00	3.32	4.02	4.72	5.42
	1600	0.78	0.94	1.10	1.26	1.41	1.73	2.05	2.36	2.68	2.99	3.31	4.01	4.71	5.41
	1800	0.77	0.93	1.09	1.25	1.41	1.73	2.04	2.36	2.67	2.98	3.30	4.00	4.70	5.40
	2000	0.77	0.93	1.09	1.25	1.41	1.72	2.04	2.35	2.66	2.97	3.29	3.99	4.69	5.39
	2400	0.76	0.92	1.08	1.24	1.40	1.71	2.03	2.34	2.65	2.96	3.27	3.97	4.67	5.37
Length Correction Factor	2800	0.76	0.92	1.08	1.23	1.39	1.71	2.02	2.33	2.63	2.95	3.56	4.17	4.78	5.38
	3200	0.76	0.92	1.07	1.23	1.39	1.70	2.01	2.32	2.62	2.93	3.54	4.15	4.76	5.36
	3600	0.75	0.91	1.07	1.22	1.38	1.69	2.00	2.31	2.62	2.92	3.53	4.14	4.74	5.35
	4000	0.75	0.91	1.06	1.22	1.38	1.69	2.00	2.30	2.61	2.91	3.52	4.13	4.73	5.33
	5000	0.75	0.90	1.06	1.21	1.37	1.68	1.98	2.29	2.59	2.90	3.50	4.10	4.70	5.29
	6000	0.74	0.90	1.05	1.20	1.36	1.67	1.97	2.27	2.58	2.88	3.48	4.08	4.67	5.26
Length Correction Factor	8000	0.73	0.89	1.04	1.19	1.35	1.65	1.95	2.25	2.55	2.85	3.45	4.04	4.63	5.21
	10000	0.73	0.88	1.03	1.18	1.34	1.64	1.94	2.24	2.53	2.83	3.42	4.01	4.59	5.17
	12000	0.72	0.88	1.03	1.18	1.33	1.63	1.93	2.22	2.52	2.82	3.40	3.98	4.56	5.14
	14000	0.72	0.87	1.02	1.17	1.32	1.62	1.92	2.21	2.51	2.80	3.38	3.96	4.53	5.11

For Belt Length	Length (mm)		100	106	124	146	170	198	232	272	318	372	436	510	598	698	
	From	To	50	53	62	73	85	99	116	136	159	186	218	255	299	349	
Length Correction Factor	# of teeth		104	122	144	168	196	230	270	316	370	434	508	596	696	800	800
	# of teeth		52	61	72	84	98	115	135	158	185	217	254	298	348	400	400
Length Correction Factor				0.70	0.75	0.80	0.85	0.90	0.95	1.00	1.05	1.10	1.15	1.20	1.25	1.30	1.35

Continued on the next page

# TIMING BELTS, PULLEYS, CHAINS AND SPROCKETS

**Table 33 (Cont.) Rated Torque (Nm) for Small Pulleys - 6 mm Belt Width**

The following table represents the torque ratings for each belt, in its base width, at the predetermined number of grooves, pitch diameters and rpm's. These ratings must be multiplied by the appropriate width factor and applicable belt length factor to obtain the corrected torque rating (see **Step 7 of SECTION 24**, on page T-65).

## 2 mm Pitch PowerGrip® GT®3 Belts

Belt Width (mm)	4	6	9	12
Width Multiplier	0.67	1.00	1.50	2.00

Number of Grooves	Pitch Diameter	12	14	16	18	20	24	28	32	36	40	48	56	64	72	80
		mm	mm	mm	mm	mm	mm	mm	mm	mm	mm	mm	mm	mm	mm	mm
10	10	7.64	8.91	10.19	11.46	12.73	15.28	17.83	20.37	22.92	25.46	30.56	35.65	40.74	45.84	50.93
	20	0.301	0.351	0.401	0.451	0.501	0.602	0.702	0.802	0.902	1.003	1.203	1.404	1.604	1.805	2.005
	40	0.10	0.12	0.14	0.16	0.18	0.23	0.27	0.31	0.35	0.39	0.47	0.55	0.63	0.71	0.79
	60	0.10	0.12	0.14	0.16	0.18	0.22	0.26	0.30	0.33	0.37	0.45	0.53	0.61	0.68	0.76
	80	0.10	0.12	0.14	0.16	0.18	0.21	0.25	0.29	0.33	0.37	0.45	0.52	0.60	0.68	0.75
	100	0.10	0.12	0.13	0.15	0.17	0.21	0.25	0.29	0.33	0.36	0.44	0.52	0.59	0.67	0.74
rpm of Fastest Shaft	200	0.09	0.11	0.13	0.15	0.17	0.21	0.25	0.28	0.32	0.36	0.43	0.51	0.58	0.65	0.73
	300	0.09	0.11	0.13	0.15	0.17	0.21	0.24	0.28	0.32	0.35	0.43	0.50	0.57	0.65	0.72
	400	0.09	0.11	0.13	0.15	0.17	0.20	0.24	0.28	0.31	0.35	0.42	0.50	0.57	0.64	0.71
	500	0.09	0.11	0.13	0.15	0.17	0.20	0.24	0.28	0.31	0.35	0.42	0.49	0.57	0.64	0.71
	600	0.09	0.11	0.13	0.15	0.16	0.20	0.24	0.27	0.31	0.35	0.42	0.49	0.56	0.64	0.71
	800	0.09	0.11	0.13	0.14	0.16	0.20	0.24	0.27	0.31	0.34	0.42	0.49	0.56	0.63	0.70
[Tabulated values are in Nm]	1000	0.09	0.11	0.13	0.14	0.16	0.20	0.23	0.27	0.31	0.34	0.41	0.48	0.56	0.63	0.70
	1200	0.09	0.11	0.12	0.14	0.16	0.20	0.23	0.27	0.31	0.34	0.41	0.48	0.55	0.62	0.69
	1400	0.09	0.11	0.12	0.14	0.16	0.20	0.23	0.27	0.30	0.34	0.41	0.48	0.55	0.62	0.69
	1600	0.09	0.11	0.12	0.14	0.16	0.20	0.23	0.27	0.30	0.34	0.41	0.48	0.55	0.62	0.69
	1800	0.09	0.11	0.12	0.14	0.16	0.20	0.23	0.27	0.30	0.34	0.41	0.48	0.55	0.62	0.69
	2000	0.09	0.10	0.12	0.14	0.16	0.19	0.23	0.27	0.30	0.34	0.41	0.48	0.54	0.61	0.68
Length Correction Factor	2400	0.09	0.10	0.12	0.14	0.16	0.19	0.23	0.26	0.30	0.33	0.40	0.47	0.54	0.61	0.68
	2800	0.09	0.10	0.12	0.14	0.16	0.19	0.23	0.26	0.30	0.33	0.40	0.47	0.54	0.61	0.68
	3200	0.09	0.10	0.12	0.14	0.16	0.19	0.23	0.26	0.30	0.33	0.40	0.47	0.54	0.61	0.68
	3600	0.09	0.10	0.12	0.14	0.16	0.19	0.23	0.26	0.30	0.33	0.40	0.47	0.54	0.61	0.67
	4000	0.08	0.10	0.12	0.14	0.16	0.19	0.23	0.26	0.30	0.33	0.40	0.47	0.53	0.60	0.67
	5000	0.08	0.10	0.12	0.14	0.15	0.19	0.22	0.26	0.29	0.33	0.40	0.46	0.53	0.60	0.66
Length Correction Factor	6000	0.08	0.10	0.12	0.14	0.15	0.19	0.22	0.26	0.29	0.33	0.39	0.46	0.53	0.59	0.66
	8000	0.08	0.10	0.12	0.13	0.15	0.19	0.22	0.25	0.29	0.32	0.39	0.46	0.52	0.59	0.66
	10000	0.08	0.10	0.12	0.13	0.15	0.19	0.22	0.25	0.29	0.32	0.39	0.45	0.52	0.58	0.65
	12000	0.08	0.10	0.12	0.13	0.15	0.18	0.22	0.25	0.28	0.32	0.38	0.45	0.52	0.58	0.64
14000	0.08	0.10	0.12	0.13	0.15	0.18	0.22	0.25	0.28	0.32	0.38	0.45	0.52	0.58	0.64	

From	To	Length Correction Factor															
		100	106	124	146	170	198	232	272	318	372	436	510	598	698		
For Belt Length	# of teeth	50	53	62	73	85	99	116	136	159	186	218	255	299	349		
	# of teeth	104	122	144	168	196	230	270	316	370	434	508	596	696	800		
Length Correction Factor		0.70	0.75	0.80	0.85	0.90	0.95	1.00	1.05	1.10	1.15	1.20	1.25	1.30	1.35		



# TIMING BELTS, PULLEYS, CHAINS AND SPROCKETS

**Table 34 (Cont.) Rated Torque (Nm) for Small Pulleys - 6 mm Belt Width**

The following table represents the torque ratings for each belt, in its base width, at the predetermined number of grooves, pitch diameters and rpm's. These ratings must be multiplied by the appropriate width factor and applicable belt length factor to obtain the corrected torque rating (see **Step 7 of SECTION 24**, on page T-65).

## 3 mm Pitch PowerGrip® GT®3 Belts

Belt Width (mm)	6	9	12	15
Width Multiplier	1.00	1.50	2.00	2.50

Number of Grooves Pitch Diameter	mm inches	16	18	20	22	24	26	30	34	38	44	50	56	64	72	80
		10	15.28 0.602	17.19 0.677	19.10 0.752	21.01 0.827	22.92 0.902	24.83 0.977	28.65 1.128	32.47 1.278	36.29 1.429	42.02 1.654	47.75 1.880	53.48 2.105	61.12 2.406	68.75 2.707
20	1.58	1.84	2.09	2.34	2.59	2.83	3.32	3.80	4.27	4.97	5.66	6.34	7.24	8.13	9.00	
40	1.45	1.69	1.92	2.15	2.38	2.61	3.06	3.51	3.95	4.60	5.24	5.87	6.70	7.52	8.32	
60	1.31	1.53	1.75	1.97	2.18	2.39	2.81	3.22	3.63	4.23	4.82	5.40	6.16	6.91	7.35	
100	1.23	1.44	1.65	1.86	2.06	2.26	2.66	3.05	3.44	4.01	4.57	5.12	5.84	6.55	7.25	
200	1.13	1.33	1.53	1.72	1.91	2.10	2.47	2.84	3.20	3.73	4.26	4.77	5.44	6.10	6.75	
300	1.00	1.18	1.36	1.53	1.71	1.88	2.22	2.55	2.88	3.36	3.83	4.29	4.90	5.49	6.07	
400	0.92	1.09	1.26	1.42	1.59	1.75	2.07	2.38	2.69	3.14	3.58	4.02	4.58	5.13	5.68	
500	0.86	1.03	1.19	1.35	1.50	1.66	1.97	2.26	2.56	2.99	3.41	3.82	4.36	4.88	5.39	
600	0.82	0.98	1.13	1.29	1.44	1.59	1.88	2.17	2.45	2.87	3.27	3.67	4.18	4.68	5.17	
800	0.78	0.94	1.09	1.24	1.39	1.53	1.82	2.10	2.37	2.77	3.16	3.54	4.04	4.52	4.99	
1000	0.73	0.87	1.02	1.16	1.30	1.44	1.71	1.98	2.24	2.61	2.98	3.34	3.81	4.27	4.71	
1200	0.68	0.82	0.96	1.10	1.24	1.37	1.63	1.88	2.13	2.49	2.85	3.19	3.63	4.07	4.49	
1400	0.65	0.78	0.92	1.05	1.18	1.31	1.56	1.81	2.05	2.40	2.73	3.06	3.49	3.90	4.31	
1600	0.62	0.75	0.88	1.01	1.14	1.26	1.51	1.74	1.97	2.31	2.64	2.96	3.37	3.77	4.15	
1800	0.59	0.72	0.85	0.97	1.10	1.22	1.46	1.69	1.91	2.24	2.56	2.86	3.26	3.64	4.02	
2000	0.57	0.69	0.82	0.94	1.06	1.18	1.41	1.64	1.86	2.17	2.48	2.78	3.16	3.54	3.89	
2400	0.55	0.67	0.79	0.91	1.03	1.15	1.37	1.59	1.81	2.12	2.42	2.71	3.08	3.44	3.78	
2800	0.51	0.63	0.75	0.86	0.98	1.09	1.31	1.52	1.72	2.02	2.30	2.58	2.93	3.27	3.59	
3200	0.48	0.60	0.71	0.82	0.93	1.04	1.25	1.45	1.65	1.93	2.20	2.46	2.80	3.12	3.42	
3600	0.45	0.57	0.68	0.79	0.89	1.00	1.20	1.39	1.58	1.85	2.12	2.36	2.68	2.98	3.27	
4000	0.43	0.54	0.65	0.75	0.86	0.96	1.15	1.34	1.53	1.79	2.04	2.28	2.58	2.86	3.13	
5000	0.41	0.52	0.62	0.73	0.83	0.92	1.11	1.30	1.47	1.73	1.97	2.19	2.48	2.75	3.00	
6000	0.37	0.47	0.57	0.66	0.76	0.85	1.03	1.20	1.36	1.59	1.81	2.01	2.26	2.49	2.70	
8000	0.33	0.43	0.52	0.61	0.70	0.79	0.96	1.11	1.27	1.48	1.67	1.85	2.07	2.26	2.42	
10000	0.30	0.36	0.45	0.53	0.61	0.69	0.84	0.97	1.10	1.28	1.44	1.57	1.71	1.82	1.88	
12000	0.22	0.31	0.39	0.46	0.54	0.61	0.74	0.86	0.97	1.11	1.22	1.30	1.37	—	—	
14000	0.19	0.26	0.34	0.41	0.47	0.53	0.65	0.75	0.84	0.94	1.01	—	—	—	—	
16000	0.15	0.22	0.29	0.35	0.41	0.47	0.57	0.65	0.72	0.78	—	—	—	—	—	

rpm of Fastest Shaft  
[Tabulated values are in Nm]

For Belt Length	From	To	Length Correction Factor																												
			Length (mm)	# of teeth	Length (mm)	# of teeth	Length (mm)	# of teeth	Length (mm)	# of teeth	Length (mm)	# of teeth	Length (mm)	# of teeth	Length (mm)	# of teeth	Length (mm)	# of teeth													
			120	40	129	43	153	51	180	60	213	71	252	84	294	98	348	116	408	136	480	160	567	189	666	222	786	262	924	308	1092
			126	46	150	49	177	57	210	69	249	83	291	98	345	115	395	135	477	159	564	188	663	221	783	261	921	307	1089	364	1200
			142	50	175	55	201	65	240	78	285	91	330	111	385	135	450	159	585	188	663	221	783	261	921	307	1089	364	1200	400	1350
			160	55	201	65	240	78	285	91	330	111	385	135	450	159	585	188	663	221	783	261	921	307	1089	364	1200	400	1350	450	1500

Shaded area indicates drive conditions where reduced service life can be expected.

# TIMING BELTS, PULLEYS, CHAINS AND SPROCKETS

**Table 35 Rated Torque (lbf in.) for Small Pulleys - 15 mm Belt Width**  
(see Table 36 for hp or KW ratings)

The following table represents the torque ratings for each belt, in its base width, at the predetermined number of grooves, pitch diameters and rpm's. These ratings must be multiplied by the appropriate width factor and applicable belt length factor to obtain the corrected torque rating (see Step 7 of SECTION 24, on page T-65).

## 5 mm Pitch PowerGrip® GT®3 Belts

Belt Width (mm)	9	15	20	25
Width Multiplier	0.60	1.00	1.33	1.67

Number of Grooves Pitch Diameter	18	20	22	24	26	28	32	36	40	44	48	56	64	72	80
	mm	28.65	31.83	35.01	38.20	41.38	44.56	50.93	57.30	63.66	70.03	76.39	89.13	101.86	114.59
inches	1.128	1.253	1.379	1.504	1.629	1.754	2.005	2.256	2.506	2.757	3.008	3.509	4.010	4.511	5.013
10	78.24	93.61	109.00	124.20	139.30	154.30	184.30	214.10	243.60	272.90	302.10	359.90	417.20	474.10	530.60
20	72.38	87.11	101.80	116.40	130.90	145.20	173.90	202.40	230.60	258.60	286.50	341.70	396.40	450.60	504.60
40	66.53	80.60	94.69	108.60	122.40	136.10	163.50	190.70	217.60	244.30	270.90	323.50	375.60	427.20	478.50
60	63.11	76.80	90.51	104.00	117.50	130.80	157.50	183.90	209.90	235.90	261.80	312.90	363.40	413.50	463.30
100	58.80	72.01	85.23	98.27	111.20	124.10	149.80	175.20	200.40	225.40	250.30	299.50	348.10	396.30	444.10
200	52.94	65.51	78.08	90.46	102.80	115.00	139.40	163.50	187.40	211.10	234.70	281.20	327.30	372.80	418.10
300	49.52	61.70	73.89	85.90	97.83	109.70	133.30	156.70	179.70	202.70	225.50	270.60	315.10	359.10	402.80
400	47.09	59.00	70.92	82.65	94.31	105.90	129.00	151.80	174.30	196.70	219.00	263.00	306.40	349.30	391.80
500	45.20	56.91	68.61	80.14	91.59	103.00	125.60	148.00	170.10	192.10	213.90	257.00	299.60	341.60	383.30
600	43.66	55.19	66.73	78.08	89.36	100.60	122.90	144.90	166.70	188.30	209.80	252.20	294.00	335.20	376.20
800	41.22	52.49	63.74	74.83	85.83	96.76	118.50	140.00	161.20	182.30	203.20	244.40	285.10	325.20	364.90
1000	39.33	50.38	61.43	72.30	83.09	93.80	115.10	136.20	156.90	177.60	198.00	238.30	278.00	317.20	355.90
1200	37.78	48.66	59.53	70.22	80.83	91.37	112.30	133.00	153.40	173.70	193.70	233.30	272.10	310.40	348.20
1400	36.47	47.20	57.92	68.46	78.82	89.31	109.90	130.30	150.40	170.30	190.10	228.90	267.00	304.50	341.40
1600	35.33	45.93	56.51	66.93	77.25	87.50	107.90	128.00	147.80	167.40	186.80	225.00	262.40	299.20	335.30
1800	34.32	44.80	55.27	65.57	75.77	85.90	106.00	125.90	145.40	164.70	183.90	221.50	258.20	294.30	329.60
2000	33.41	43.79	54.16	64.34	74.44	84.46	104.30	124.00	143.20	162.30	181.20	218.20	254.40	289.70	324.20
2400	31.84	42.03	52.20	62.20	72.10	81.92	101.40	120.60	139.40	158.00	176.40	212.30	247.20	281.10	314.10
2800	30.49	40.53	50.53	60.36	70.09	79.73	98.84	117.60	136.00	154.20	172.10	206.90	240.60	273.10	304.40
3200	29.31	39.20	49.06	58.73	68.31	77.79	96.54	115.00	132.90	150.70	168.10	201.80	234.20	265.30	294.90
3600	28.26	38.02	47.74	57.27	66.70	76.02	94.45	112.50	130.10	147.40	164.30	197.00	228.10	257.60	285.30
4000	27.31	36.94	46.53	55.93	65.21	74.39	92.50	110.20	127.40	144.30	160.70	192.30	222.00	249.80	275.70
5000	25.23	34.58	43.88	52.96	61.91	70.74	88.07	104.90	121.10	136.90	152.10	180.60	206.70	230.00	—
6000	23.45	32.55	41.56	50.35	58.98	67.46	84.01	99.93	115.10	129.70	143.50	168.70	190.60	—	—
8000	20.43	29.03	37.50	45.69	53.67	61.43	76.33	90.27	103.10	115.00	125.60	—	—	—	—
10000	17.77	25.88	33.79	41.35	48.63	55.06	68.66	80.34	—	—	—	—	—	—	—
12000	15.29	22.88	30.19	37.07	43.57	49.67	60.63	—	—	—	—	—	—	—	—
14000	12.88	19.91	26.56	32.69	38.34	43.46	—	—	—	—	—	—	—	—	—

[Tabulated values are in lbf in.]

For Belt Length	Length (mm)		200		215		260		315		375		450		540		650		780		935		1130		1355		1625		1960																																							
	From	To	# of teeth	Length (mm)	# of teeth	Length (mm)	# of teeth	Length (mm)	# of teeth	Length (mm)	# of teeth	Length (mm)	# of teeth	Length (mm)	# of teeth	Length (mm)	# of teeth	Length (mm)	# of teeth	Length (mm)	# of teeth	Length (mm)	# of teeth	Length (mm)	# of teeth	Length (mm)	# of teeth	Length (mm)	# of teeth																																							
Length Correction Factor	0.65	0.70	0.75	0.80	0.85	0.90	0.95	1.00	1.05	1.10	1.15	1.20	1.25	1.30	1.35	1.40	1.45	1.50	1.55	1.60	1.65	1.70	1.75	1.80	1.85	1.90	1.95	2.00	2.05	2.10	2.15	2.20	2.25	2.30	2.35	2.40	2.45	2.50	2.55	2.60	2.65	2.70	2.75	2.80	2.85	2.90	2.95	3.00	3.05	3.10	3.15	3.20	3.25	3.30	3.35	3.40	3.45	3.50	3.55	3.60	3.65	3.70	3.75	3.80	3.85	3.90	3.95	4.00

Continued on the next page

Shaded area indicates drive conditions where reduced service life can be expected.

# TIMING BELTS, PULLEYS, CHAINS AND SPROCKETS

**Table 35 (Cont.) Rated Torque (Nm) for Small Pulleys - 15 mm Belt Width**

The following table represents the torque ratings for each belt, in its base width, at the predetermined number of grooves, pitch diameters and rpm's. These ratings must be multiplied by the appropriate width factor and applicable belt length factor to obtain the corrected torque rating (see Step 7 of SECTION 24, on page T-65).

## 5 mm Pitch PowerGrip® GT®3 Belts

Belt Width (mm)	9	15	20	25
Width Multiplier	0.60	1.00	1.33	1.67

Number of Grooves Pitch Diameter	18	20	22	24	26	28	32	36	40	44	48	56	64	72	80
	mm inches	mm inches	mm inches	mm inches	mm inches	mm inches	mm inches	mm inches	mm inches	mm inches	mm inches	mm inches	mm inches	mm inches	mm inches
10	8.84	10.58	12.32	14.03	15.74	17.44	20.83	24.19	27.52	30.84	34.14	40.67	47.14	53.56	59.95
	8.18	9.84	11.51	13.15	14.78	16.41	19.65	22.87	26.05	29.22	32.37	38.61	44.79	50.92	57.01
	7.52	9.11	10.70	12.27	13.83	15.38	18.48	21.55	24.58	27.60	30.61	36.55	42.44	48.27	54.07
	6.86	8.48	10.03	11.57	13.12	14.67	17.79	20.77	23.72	26.66	29.58	35.35	41.06	46.72	52.35
	6.24	7.84	9.33	10.83	12.32	13.81	16.92	19.80	22.64	25.47	28.28	33.83	39.33	44.77	50.18
	5.62	7.20	8.69	10.18	11.67	13.16	16.27	19.15	21.98	24.81	27.64	32.98	38.33	43.67	49.01
200	5.98	7.40	8.82	10.22	11.61	12.99	15.75	18.48	21.17	23.85	26.51	31.78	36.98	42.13	47.24
	5.59	6.98	8.38	9.71	11.05	12.39	15.06	17.70	20.31	22.90	25.48	30.57	35.60	40.57	45.51
	5.32	6.67	8.01	9.34	10.66	11.96	14.57	17.15	19.70	22.23	24.74	29.71	34.61	39.46	44.27
	5.11	6.43	7.75	9.05	10.35	11.63	14.19	16.72	19.22	21.71	24.17	29.04	33.85	38.60	43.31
	4.93	6.24	7.54	8.82	10.10	11.36	13.88	16.37	18.83	21.28	23.70	28.49	33.22	37.88	42.51
	4.66	5.93	7.20	8.45	9.70	10.93	13.39	15.82	18.21	20.60	22.96	27.62	32.21	36.74	41.23
1000	4.44	5.69	6.94	8.17	9.39	10.60	13.01	15.39	17.73	20.06	22.37	26.93	31.41	35.84	40.21
	4.27	5.50	6.73	7.93	9.13	10.32	12.69	15.03	17.33	19.62	21.89	26.36	30.75	35.07	39.34
	4.12	5.33	6.54	7.73	8.92	10.09	12.42	14.73	16.99	19.24	21.47	25.86	30.17	34.40	38.58
	3.99	5.19	6.39	7.56	8.73	9.89	12.19	14.46	16.69	18.91	21.11	25.42	29.65	33.80	37.89
	3.88	5.06	6.24	7.41	8.56	9.71	11.98	14.22	16.43	18.61	20.78	25.02	29.18	33.25	37.24
	3.78	4.95	6.12	7.27	8.41	9.54	11.79	14.01	16.18	18.34	20.47	24.65	28.74	32.73	36.63
2000	3.60	4.75	5.90	7.03	8.15	9.26	11.46	13.62	15.75	17.85	19.93	23.98	27.93	31.76	35.49
	3.45	4.58	5.71	6.82	7.92	9.01	11.17	13.29	15.37	17.42	19.44	23.88	27.78	31.58	35.29
	3.31	4.43	5.54	6.64	7.72	8.79	10.91	12.99	15.02	17.02	18.99	22.80	26.67	30.52	34.33
	3.19	4.30	5.39	6.47	7.54	8.59	10.67	12.71	14.70	16.65	18.57	22.26	26.17	29.10	32.94
	3.09	4.17	5.26	6.32	7.37	8.41	10.45	12.45	14.40	16.30	18.16	21.72	25.08	28.23	31.15
	2.85	3.91	4.96	5.98	7.00	7.99	9.95	11.85	13.68	15.46	17.18	20.41	23.35	25.99	—
5000	2.65	3.68	4.70	5.69	6.66	7.62	9.49	11.29	13.01	14.65	16.21	19.06	21.54	—	—
	2.51	3.54	4.54	5.51	6.46	7.41	9.26	10.96	12.61	14.21	15.76	18.57	21.06	—	—
	2.31	3.42	4.41	5.38	6.33	7.28	9.03	10.68	12.28	13.88	15.43	18.24	20.74	—	—
	2.03	3.28	4.26	5.23	6.18	7.13	8.88	10.48	12.08	13.68	15.23	18.04	20.54	—	—
	1.73	2.59	3.41	4.19	4.92	5.61	6.85	—	—	—	—	—	—	—	—
	1.45	2.25	3.00	3.69	4.33	4.91	—	—	—	—	—	—	—	—	—

For Belt Length	From	Length (mm)														
		200	215	260	315	375	450	540	650	780	935	1130	1355	1625	1960	
Length	To	40	43	52	63	75	90	108	130	156	187	226	271	325	392	
	# of teeth	210	255	310	370	445	535	645	775	930	1125	1350	1620	1955	2000	
Length Correction Factor	To	42	51	62	74	89	107	129	155	186	225	270	324	391	400	
	# of teeth	0.65	0.70	0.75	0.80	0.85	0.90	0.95	1.00	1.05	1.10	1.15	1.20	1.25	1.30	

Shaded area indicates drive conditions where reduced service life can be expected.

# TIMING BELTS, PULLEYS, CHAINS AND SPROCKETS

**Table 36 Rated Horsepower for Small Pulleys - 15 mm Belt Width**

The following table represents the horsepower ratings for each belt, in its base width, at the predetermined number of grooves, pitch diameter and rpm's. These ratings must be multiplied by the appropriate width factor and applicable belt length factor to obtain the corrected horsepower rating (see Step 7 of SECTION 24, on page T-65). See Table 35 for torque ratings.

## 5 mm Pitch PowerGrip® GT®3 Belts

Belt Width (mm)	9	15	20	25
Width Multiplier	0.60	1.00	1.33	1.67

Number of Grooves Pitch Diameter	18	20	22	24	26	28	32	36	40	44	48	56	64	72	80
	mm inches	mm inches	mm inches	mm inches	mm inches	mm inches	mm inches	mm inches	mm inches	mm inches	mm inches	mm inches	mm inches	mm inches	mm inches
10	0.01	0.01	0.02	0.02	0.02	0.02	0.03	0.03	0.04	0.04	0.05	0.06	0.07	0.08	0.08
	0.02	0.03	0.03	0.04	0.04	0.05	0.06	0.06	0.07	0.08	0.09	0.11	0.13	0.14	0.16
	0.04	0.05	0.06	0.07	0.08	0.10	0.12	0.12	0.14	0.16	0.17	0.21	0.24	0.27	0.30
	0.06	0.07	0.09	0.10	0.11	0.12	0.15	0.18	0.20	0.22	0.25	0.30	0.35	0.39	0.44
	0.09	0.11	0.14	0.16	0.18	0.20	0.24	0.28	0.32	0.36	0.40	0.48	0.55	0.63	0.70
	0.17	0.21	0.25	0.29	0.33	0.36	0.44	0.52	0.59	0.67	0.74	0.89	1.04	1.18	1.33
200	0.24	0.29	0.35	0.41	0.47	0.52	0.63	0.75	0.86	0.96	1.07	1.29	1.50	1.71	1.92
	0.30	0.37	0.45	0.52	0.60	0.67	0.82	0.96	1.11	1.25	1.39	1.67	1.94	2.22	2.49
	0.36	0.45	0.54	0.64	0.73	0.82	1.00	1.17	1.35	1.52	1.70	2.04	2.38	2.71	3.04
	0.42	0.53	0.64	0.74	0.85	0.96	1.17	1.38	1.59	1.79	2.00	2.40	2.80	3.19	3.58
	0.52	0.67	0.81	0.95	1.09	1.23	1.50	1.78	2.05	2.31	2.58	3.10	3.62	4.13	4.63
	0.62	0.80	0.97	1.15	1.32	1.49	1.83	2.16	2.49	2.82	3.14	3.78	4.41	5.03	5.65
1000	0.72	0.93	1.13	1.34	1.54	1.74	2.14	2.53	2.92	3.31	3.69	4.44	5.18	5.91	6.63
	0.81	1.05	1.29	1.52	1.75	1.98	2.44	2.90	3.34	3.78	4.22	5.08	5.93	6.76	7.58
	0.90	1.17	1.43	1.70	1.96	2.22	2.74	3.25	3.75	4.25	4.74	5.71	6.66	7.60	8.51
	0.98	1.28	1.58	1.87	2.16	2.45	3.03	3.59	4.15	4.71	5.25	6.32	7.38	8.40	9.41
	1.06	1.39	1.72	2.04	2.36	2.68	3.31	3.93	4.55	5.15	5.75	6.92	8.07	9.19	10.29
	1.21	1.60	1.99	2.37	2.75	3.12	3.86	4.59	5.31	6.02	6.72	8.08	9.41	10.70	11.96
2000	1.35	1.80	2.24	2.68	3.11	3.54	4.39	5.23	6.04	6.85	7.64	9.19	10.69	12.13	13.52
	1.49	1.99	2.49	2.98	3.47	3.95	4.90	5.84	6.75	7.65	8.53	10.25	11.89	13.47	14.97
	1.61	2.17	2.73	3.27	3.81	4.34	5.40	6.43	7.43	8.42	9.39	11.25	13.03	14.71	16.30
	1.73	2.34	2.95	3.55	4.14	4.72	5.87	6.99	8.09	9.16	10.20	12.20	14.09	15.86	17.50
	2.00	2.74	3.48	4.20	4.91	5.61	6.99	8.32	9.61	10.86	12.06	14.33	16.40	18.25	—
	2.23	3.10	3.96	4.79	5.62	6.42	8.00	9.51	10.96	12.34	13.66	16.06	18.15	—	—
[Tabulated values are in hp]	2.59	3.69	4.76	5.80	6.81	7.80	9.69	11.46	13.09	14.59	15.95	—	—	—	—
	2.82	4.11	5.36	6.56	7.72	8.82	10.89	12.75	—	—	—	—	—	—	—
	2.91	4.36	5.75	7.06	8.30	9.46	11.54	—	—	—	—	—	—	—	—
	2.86	4.42	5.90	7.26	8.52	9.65	—	—	—	—	—	—	—	—	—
	—	—	—	—	—	—	—	—	—	—	—	—	—	—	—
	—	—	—	—	—	—	—	—	—	—	—	—	—	—	—

For Belt Length	From	200	215	260	315	375	450	540	650	780	935	1130	1355	1625	1960
	To	40	43	52	63	75	90	108	130	156	187	226	271	325	392
Length Correction Factor	Length (mm)	210	255	310	370	445	535	645	775	930	1125	1350	1620	1955	2000
	# of teeth	42	51	62	74	89	107	129	155	186	225	270	324	391	400
		0.65	0.70	0.75	0.80	0.85	0.90	0.95	1.00	1.05	1.10	1.15	1.20	1.25	1.30

Continued on the next page

Shaded area indicates drive conditions where reduced service life can be expected.

# TIMING BELTS, PULLEYS, CHAINS AND SPROCKETS

**Table 36 (Cont.) Rated Kilowatts for Small Pulleys - 15 mm Belt Width**

The following table represents the horsepower ratings for each belt, in its base width, at the predetermined number of grooves, pitch diameters and rpm's. These ratings must be multiplied by the appropriate width factor and applicable belt length factor to obtain the corrected horsepower rating (see Step 7 of SECTION 24, on page T-65). See Table 45 for torque ratings.

## 5 mm Pitch PowerGrip® GT®3 Belts

Belt Width (mm)	9	15	20	25
Width Multiplier	0.60	1.00	1.33	1.67

Number of Grooves Pitch Diameter	18	20	22	24	26	28	32	36	40	44	48	56	64	72	80
	mm inches	mm inches	mm inches	mm inches	mm inches	mm inches	mm inches	mm inches	mm inches	mm inches	mm inches	mm inches	mm inches	mm inches	mm inches
rpm of Fastest Shaft	10	0.01	0.01	0.01	0.02	0.02	0.02	0.03	0.03	0.03	0.04	0.04	0.05	0.06	0.06
	20	0.02	0.02	0.02	0.03	0.03	0.04	0.05	0.05	0.06	0.07	0.08	0.09	0.10	0.11
	40	0.03	0.04	0.04	0.05	0.06	0.06	0.08	0.09	0.10	0.12	0.13	0.15	0.18	0.20
	60	0.04	0.05	0.06	0.07	0.08	0.09	0.11	0.13	0.15	0.17	0.19	0.22	0.26	0.29
	100	0.07	0.09	0.10	0.12	0.13	0.15	0.18	0.21	0.24	0.27	0.30	0.35	0.41	0.47
	200	0.13	0.16	0.18	0.21	0.24	0.27	0.33	0.39	0.44	0.50	0.56	0.67	0.77	0.88
[Tabulated values are in kW]	300	0.18	0.22	0.26	0.30	0.35	0.39	0.47	0.56	0.64	0.72	0.80	0.96	1.12	1.27
	400	0.22	0.28	0.34	0.39	0.45	0.50	0.61	0.72	0.83	0.93	1.04	1.24	1.45	1.65
	500	0.27	0.34	0.41	0.47	0.54	0.61	0.74	0.88	1.01	1.14	1.27	1.52	1.77	2.02
	600	0.31	0.39	0.47	0.55	0.63	0.71	0.87	1.03	1.18	1.34	1.49	1.79	2.09	2.38
	800	0.39	0.50	0.60	0.71	0.81	0.92	1.12	1.33	1.53	1.73	1.92	2.31	2.70	3.08
	1000	0.47	0.60	0.73	0.86	0.98	1.11	1.36	1.61	1.86	2.10	2.34	2.82	3.29	3.75
rpm of Fastest Shaft	1200	0.54	0.69	0.85	1.00	1.15	1.30	1.59	1.89	2.18	2.47	2.75	3.31	3.86	4.41
	1400	0.60	0.78	0.96	1.13	1.31	1.48	1.82	2.16	2.49	2.82	3.15	3.79	4.42	5.04
	1600	0.67	0.87	1.07	1.27	1.46	1.66	2.04	2.42	2.80	3.17	3.54	4.26	4.97	5.66
	1800	0.73	0.95	1.18	1.40	1.61	1.83	2.26	2.68	3.10	3.51	3.92	4.72	5.50	6.27
	2000	0.79	1.04	1.28	1.52	1.76	2.00	2.47	2.93	3.39	3.84	4.29	5.16	6.02	6.85
	2400	0.90	1.19	1.48	1.77	2.05	2.33	2.88	3.42	3.96	4.49	5.01	6.03	7.02	7.98
	2800	1.01	1.34	1.67	2.00	2.32	2.64	3.27	3.90	4.51	5.11	5.70	6.85	7.97	9.05
	3200	1.11	1.48	1.86	2.22	2.59	2.95	3.66	4.35	5.03	5.71	6.36	7.64	8.87	10.04
	3600	1.20	1.62	2.03	2.44	2.84	3.24	4.02	4.79	5.54	6.28	7.00	8.39	9.72	10.97
	4000	1.29	1.75	2.20	2.65	3.09	3.52	4.38	5.22	6.03	6.83	7.61	9.10	10.51	11.82
rpm of Fastest Shaft	5000	1.49	2.00	2.60	3.13	3.66	4.18	5.21	6.21	7.16	8.10	9.00	10.68	12.23	13.05
	6000	1.67	2.31	2.95	3.57	4.19	4.79	5.96	7.09	8.17	9.20	10.19	11.98	13.53	—
	8000	1.93	2.75	3.55	4.32	5.08	5.81	7.23	8.54	9.76	10.88	11.89	—	—	—
	10000	2.10	3.06	4.00	4.89	5.75	6.58	8.12	9.51	—	—	—	—	—	—
rpm of Fastest Shaft	12000	2.17	3.25	4.29	5.26	6.19	7.05	8.61	—	—	—	—	—	—	—
	14000	2.13	3.30	4.40	5.42	6.35	7.20	—	—	—	—	—	—	—	—

For Belt Length	From	To	Length (mm)													
			200	215	260	315	375	450	540	650	780	935	1130	1355	1625	1960
Length Correction Factor	# of teeth	40	43	52	63	75	90	108	130	156	187	226	271	325	392	
	# of teeth	210	255	310	370	445	535	645	775	930	1125	1350	1620	1955	2000	
Length Correction Factor	# of teeth	42	51	62	74	89	107	129	155	186	225	270	324	391	400	
	Length Correction Factor	0.65	0.70	0.75	0.80	0.85	0.90	0.95	1.00	1.05	1.10	1.15	1.20	1.25	1.30	

Shaded area indicates drive conditions where reduced service life can be expected.

# TIMING BELTS, PULLEYS, CHAINS AND SPROCKETS

I  
R  
T  
1  
2  
3  
4  
5  
6  
7  
8  
9  
10  
11  
12  
13  
14  
15  
A

**Table 37 Rated Torque (lbf in.) for Small Pulleys - 6 mm Belt Width**

The following table represents the torque ratings for each belt, in its base width, at the predetermined number of grooves, pitch diameters and rpm's. These ratings must be multiplied by the appropriate width factor and applicable belt length factor to obtain the corrected torque rating (see Step 7 of SECTION 24, on page T-65).

## 3 mm Pitch PowerGrip® HTD® Belts

<b>Belt Width (mm)</b>	<b>6</b>	<b>9</b>	<b>15</b>
<b>Width Multiplier</b>	1.00	1.66	2.97

Number of Grooves Pitch Diameter	10	12	14	16	18	22	26	30	34	38	44	50	56	62	72	80
	mm inches	mm inches	mm inches	mm inches	mm inches	mm inches	mm inches	mm inches	mm inches	mm inches	mm inches	mm inches	mm inches	mm inches	mm inches	mm inches
10	3.3 4.0	4.0 4.8	4.8 5.6	5.6 6.5	6.5 8.3	8.3 10.2	10.2 12.3	12.3 14.5	14.5 16.8	16.8 20.5	20.5 24.6	24.6 27.7	27.7 30.7	30.7 35.7	35.7 39.6	39.6 45.13
20	3.3 4.0	4.0 4.8	4.8 5.6	5.6 6.5	6.5 8.3	8.3 10.2	10.2 12.3	12.3 14.5	14.5 16.8	16.8 20.5	20.5 24.6	24.6 27.7	27.7 30.7	30.7 35.7	35.7 39.6	39.6 45.13
40	3.3 4.0	4.0 4.8	4.8 5.6	5.6 6.5	6.5 8.3	8.3 10.2	10.2 12.3	12.3 14.5	14.5 16.8	16.8 20.5	20.5 24.6	24.6 27.7	27.7 30.7	30.7 35.7	35.7 39.6	39.6 45.13
60	3.3 4.0	4.0 4.8	4.8 5.6	5.6 6.5	6.5 8.3	8.3 10.2	10.2 12.3	12.3 14.5	14.5 16.8	16.8 20.5	20.5 24.6	24.6 27.7	27.7 30.7	30.7 35.7	35.7 39.6	39.6 45.13
100	3.3 4.0	4.0 4.8	4.8 5.6	5.6 6.5	6.5 8.3	8.3 10.2	10.2 12.3	12.3 14.5	14.5 16.8	16.8 20.5	20.5 24.6	24.6 27.7	27.7 30.7	30.7 35.7	35.7 39.6	39.6 45.13
200	3.3 4.0	4.0 4.8	4.8 5.6	5.6 6.5	6.5 8.3	8.3 10.2	10.2 12.3	12.3 14.5	14.5 16.8	16.8 20.5	20.5 24.6	24.6 27.7	27.7 30.7	30.7 35.7	35.7 39.6	39.6 45.13
300	3.0 3.7	4.4 5.1	5.1 5.9	5.9 7.5	7.5 9.2	9.2 11.1	11.1 13.0	13.0 15.0	15.0 18.3	18.3 21.8	21.8 25.0	25.0 29.1	29.1 32.3	32.3 35.2	35.2 38.6	38.6 42.2
400	2.8 3.4	4.1 4.8	4.8 5.5	5.5 7.0	7.0 8.6	8.6 10.3	10.3 12.0	12.0 13.9	13.9 16.9	16.9 20.0	20.0 22.6	22.6 25.0	25.0 29.1	29.1 32.3	32.3 35.2	35.2 38.6
500	2.7 3.3	3.9 4.5	4.5 5.2	5.2 6.6	6.6 8.1	8.1 9.7	9.7 11.3	11.3 13.1	13.1 15.8	15.8 18.8	18.8 21.2	21.2 23.4	23.4 27.2	27.2 30.2	30.2 32.6	32.6 35.2
600	2.6 3.1	3.7 4.3	4.3 5.0	5.0 6.3	6.3 7.7	7.7 9.2	9.2 10.8	10.8 12.4	12.4 15.0	15.0 17.8	17.8 20.1	20.1 22.2	22.2 25.8	25.8 28.6	28.6 31.6	31.6 35.2
700	2.5 3.0	3.6 4.2	4.2 4.8	4.8 5.6	5.6 6.1	6.1 7.2	7.2 8.6	8.6 10.4	10.4 11.9	11.9 14.4	14.4 17.0	17.0 19.2	19.2 21.2	21.2 24.6	24.6 27.4	27.4 30.2
800	2.4 2.9	3.5 4.1	4.1 4.7	4.7 5.9	5.9 7.2	7.2 8.6	8.6 10.0	10.0 11.5	11.5 13.9	13.9 16.3	16.3 18.4	18.4 20.4	20.4 23.7	23.7 26.3	26.3 29.1	29.1 32.3
870	2.4 2.9	3.4 4.0	4.0 4.6	4.6 5.8	5.8 7.0	7.0 8.4	8.4 9.8	9.8 11.2	11.2 13.5	13.5 15.9	15.9 18.0	18.0 19.9	19.9 23.1	23.1 25.6	25.6 28.6	28.6 31.6
1000	2.3 2.8	3.3 3.9	3.9 4.4	4.4 5.6	5.6 6.8	6.8 8.1	8.1 9.4	9.4 10.8	10.8 13.0	13.0 15.3	15.3 17.2	17.2 19.1	19.1 22.1	22.1 24.6	24.6 27.2	27.2 30.2
1160	2.2 2.7	3.2 3.7	3.7 4.3	4.3 5.4	5.4 6.5	6.5 7.8	7.8 9.1	9.1 10.4	10.4 12.5	12.5 14.6	14.6 16.5	16.5 18.2	18.2 21.2	21.2 23.5	23.5 26.3	26.3 29.1
1450	2.1 2.6	3.0 3.5	3.5 4.0	4.0 5.1	5.1 6.2	6.2 7.3	7.3 8.5	8.5 9.8	9.8 11.7	11.7 13.7	13.7 15.4	15.4 17.1	17.1 19.8	19.8 22.0	22.0 24.6	24.6 27.4
1600	2.0 2.5	3.0 3.4	3.4 3.9	3.9 5.0	5.0 6.0	6.0 7.2	7.2 8.3	8.3 9.5	9.5 11.4	11.4 13.3	13.3 15.0	15.0 16.5	16.5 19.2	19.2 21.3	21.3 23.7	23.7 26.3
1750	2.0 2.5	2.9 3.4	3.4 3.9	3.9 4.9	4.9 5.9	5.9 7.0	7.0 8.1	8.1 9.3	9.3 11.1	11.1 12.9	12.9 14.6	14.6 16.1	16.1 18.7	18.7 20.7	20.7 23.1	23.1 25.6
2000	1.9 2.4	2.8 3.3	3.3 3.7	3.7 4.7	4.7 5.7	5.7 6.7	6.7 7.8	7.8 8.9	8.9 10.7	10.7 12.4	12.4 14.0	14.0 15.4	15.4 17.9	17.9 19.8	19.8 21.8	21.8 24.6
2500	1.9 2.3	2.7 3.1	3.1 3.5	3.5 4.4	4.4 5.4	5.4 6.4	6.4 7.4	7.4 8.4	8.4 10.0	10.0 11.6	11.6 13.0	13.0 14.4	14.4 16.6	16.6 18.4	18.4 20.7	20.7 23.1
3000	1.8 2.2	2.6 3.0	3.0 3.4	3.4 4.2	4.2 5.1	5.1 6.1	6.1 7.0	7.0 8.0	8.0 9.4	9.4 11.0	11.0 12.3	12.3 13.5	13.5 15.6	15.6 17.3	17.3 19.1	19.1 21.3
3500	1.7 2.1	2.5 2.9	2.9 3.3	3.3 4.1	4.1 4.9	4.9 5.8	5.8 6.7	6.7 7.6	7.6 9.0	9.0 10.4	10.4 11.7	11.7 12.8	12.8 14.8	14.8 16.3	16.3 18.0	18.0 20.7
5000	1.6 1.9	2.3 2.6	2.6 3.0	3.0 3.7	3.7 4.5	4.5 5.2	5.2 6.0	6.0 6.8	6.8 8.0	8.0 9.2	9.2 10.2	10.2 11.1	11.1 12.7	12.7 13.8	13.8 15.1	15.1 16.6
8000	1.4 1.7	2.0 2.3	2.3 2.6	2.6 3.0	3.0 3.3	3.3 3.9	3.9 4.5	4.5 5.1	5.1 5.7	5.7 6.6	6.6 7.3	7.3 8.0	8.0 8.5	8.5 9.1	9.1 9.3	9.3 9.3
10000	1.3 1.6	1.9 2.2	2.2 2.5	2.5 3.0	3.0 3.6	3.6 4.1	4.1 4.6	4.6 5.1	5.1 5.7	5.7 6.3	6.3 6.6	6.6 6.8	6.8 6.8	6.8 6.8	6.8 6.8	6.8 6.8

rpm of Fastest Shaft  
[Tabulated values are in lbf in.]

For Belt Length	Length (mm)		Length (mm)		Length (mm)	
	From		To		Length Correction Factor	
	# of teeth	600	# of teeth	200	# of teeth	201 & up
	144	198	264	408	600	200
	48	66	88	136	200	603 & up
	195	261	405	597	603 & up	201 & up
	65	87	135	199	201 & up	1.20
	0.80	0.90	1.00	1.10	1.20	

Continued on the next page  
Shaded area indicates drive conditions where reduced service life can be expected.

# TIMING BELTS, PULLEYS, CHAINS AND SPROCKETS

**Table 37 (Cont.) Rated Torque (Nm) for Small Pulleys - 6 mm Belt Width**  
 The following table represents the torque ratings for each belt, in its base width, at the predetermined number of grooves, pitch diameters and rpm's. These ratings must be multiplied by the appropriate width factor and applicable belt length factor to obtain the corrected torque rating (see **Step 7** of **SECTION 24**, on page **T-65**).

## 3 mm Pitch PowerGrip® HTD® Belts

<b>Belt Width (mm)</b>	<b>6</b>	<b>9</b>	<b>15</b>
<b>Width Multiplier</b>	1.00	1.66	2.97

Number of Grooves Pitch Diameter	10	12	14	16	18	22	26	30	34	38	44	50	56	62	72	80	
	mm	9.55	11.46	13.37	15.28	17.19	21.01	24.83	28.65	32.47	36.29	42.02	47.75	53.48	59.21	68.75	76.39
inches	.376	.451	.526	.602	.677	.827	.977	1.128	1.278	1.429	1.654	1.880	2.105	2.331	2.707	3.008	
rpm of Fastest Shaft [Tabulated values are in Nm]	10	0.4	0.5	0.6	0.7	0.9	1.2	1.4	1.6	1.9	2.3	2.8	3.1	3.5	4.0	4.5	
	20	0.4	0.5	0.5	0.6	0.7	0.9	1.2	1.4	1.6	1.9	2.3	2.8	3.1	3.5	4.0	4.5
	40	0.4	0.5	0.5	0.6	0.7	0.9	1.2	1.4	1.6	1.9	2.3	2.8	3.1	3.5	4.0	4.5
	60	0.4	0.5	0.5	0.6	0.7	0.9	1.2	1.4	1.6	1.9	2.3	2.8	3.1	3.5	4.0	4.5
	100	0.4	0.5	0.5	0.6	0.7	0.9	1.2	1.4	1.6	1.9	2.3	2.8	3.1	3.5	4.0	4.5
	200	0.4	0.5	0.5	0.6	0.7	0.9	1.2	1.4	1.6	1.9	2.3	2.8	3.1	3.5	4.0	4.5
	300	0.3	0.4	0.5	0.6	0.7	0.8	1.0	1.2	1.5	1.7	2.1	2.5	2.8	3.1	3.6	4.0
	400	0.3	0.4	0.5	0.5	0.6	0.8	1.0	1.2	1.4	1.6	1.9	2.3	2.6	2.8	3.3	3.6
	500	0.3	0.4	0.4	0.5	0.6	0.7	0.9	1.1	1.3	1.5	1.8	2.1	2.4	2.6	3.1	3.4
	600	0.3	0.4	0.4	0.5	0.6	0.7	0.9	1.0	1.2	1.4	1.7	2.0	2.3	2.5	2.9	3.2
	700	0.3	0.3	0.4	0.5	0.5	0.7	0.8	1.0	1.2	1.3	1.6	1.9	2.2	2.4	2.8	3.1
	800	0.3	0.3	0.4	0.5	0.5	0.7	0.8	1.0	1.1	1.3	1.6	1.8	2.1	2.3	2.7	3.0
	870	0.3	0.3	0.4	0.4	0.5	0.7	0.8	0.9	1.1	1.3	1.5	1.8	2.0	2.2	2.6	2.9
	1000	0.3	0.3	0.4	0.4	0.5	0.6	0.8	0.9	1.1	1.2	1.5	1.7	1.9	2.2	2.5	2.8
	1160	0.2	0.3	0.4	0.4	0.5	0.6	0.7	0.9	1.0	1.2	1.4	1.7	1.9	2.1	2.4	2.7
	1450	0.2	0.3	0.3	0.4	0.5	0.6	0.7	0.8	1.0	1.1	1.3	1.5	1.7	1.9	2.2	2.5
1600	0.2	0.3	0.3	0.4	0.4	0.6	0.7	0.8	0.9	1.1	1.3	1.5	1.7	1.9	2.2	2.4	
1750	0.2	0.3	0.3	0.4	0.4	0.5	0.7	0.8	0.9	1.0	1.3	1.5	1.6	1.8	2.1	2.3	
2000	0.2	0.3	0.3	0.4	0.4	0.5	0.6	0.8	0.9	1.0	1.2	1.4	1.6	1.7	2.0	2.2	
2500	0.2	0.3	0.3	0.4	0.4	0.5	0.6	0.7	0.8	0.9	1.1	1.3	1.5	1.6	1.9	2.1	
3000	0.2	0.2	0.3	0.3	0.4	0.5	0.6	0.7	0.8	0.9	1.1	1.2	1.4	1.5	1.8	1.9	
3500	0.2	0.2	0.3	0.3	0.4	0.5	0.6	0.7	0.8	0.9	1.0	1.2	1.3	1.5	1.7	1.8	
5000	0.2	0.2	0.3	0.3	0.3	0.4	0.5	0.6	0.7	0.8	0.9	1.0	1.2	1.3	1.4	1.6	
8000	0.2	0.2	0.2	0.3	0.3	0.4	0.4	0.5	0.6	0.6	0.7	0.8	0.9	1.0	1.0	1.1	
10000	0.2	0.2	0.2	0.2	0.3	0.3	0.4	0.4	0.5	0.6	0.6	0.7	0.7	0.8	—	—	

Shaded area indicates drive conditions where reduced service life can be expected.

For Belt Length	From	Length (mm)		From	Length (mm)	
		# of teeth	600		# of teeth	200
Length Correction Factor	To	195	261	405	597	603 & up
		65	87	135	199	201 & up
Length Correction Factor		0.80	0.90	1.00	1.10	1.20

# TIMING BELTS, PULLEYS, CHAINS AND SPROCKETS

**Table 38 Rated Torque (lbf in.) for Small Pulleys - 9 mm Belt Width**

The following table represents the torque ratings for each belt, in its base width, at the predetermined number of grooves, pitch diameters and rpm's. These ratings must be multiplied by the appropriate width factor and applicable belt length factor to obtain the corrected torque rating (see Step 7 of SECTION 24, on page T-65).

## 5 mm Pitch PowerGrip® HTD® Belts

Belt Width (mm)	9	15	25
Width Multiplier	1.00	1.89	3.38

Number of Grooves Pitch Diameter	14		16		18		20		22		24		26		28		32		36		40		44		48		56		64		72	
	mm	inches	mm	inches	mm	inches	mm	inches	mm	inches	mm	inches	mm	inches	mm	inches	mm	inches	mm	inches	mm	inches	mm	inches	mm	inches	mm	inches	mm	inches		
10	9.55	.376	11.46	.451	13.37	.526	15.28	.602	17.19	.677	21.01	.827	24.83	.977	28.65	1.128	32.47	1.278	36.29	1.429	42.02	1.654	47.75	1.880	53.48	2.105	59.21	2.331	68.75	2.707	76.39	3.008
20	19.0		22.3		25.7		29.3		33.0		36.9		40.9		45.1		53.8		63.1		73.0		83.5		94.5		113.3		129.5		145.7	
40	19.0		22.3		25.7		29.3		33.0		36.9		40.9		45.1		53.8		63.1		73.0		83.5		94.5		113.3		129.5		145.7	
60	19.0		22.3		25.7		29.3		33.0		36.9		40.9		45.1		53.8		63.1		73.0		83.5		94.5		113.3		129.5		145.7	
100	19.0		22.3		25.7		29.3		33.0		36.9		40.9		45.1		53.8		63.1		73.0		83.5		94.5		113.3		129.5		145.7	
200	19.0		22.3		25.7		29.3		33.0		36.9		40.9		45.1		53.8		63.1		73.0		83.5		94.5		113.3		129.5		145.7	
300	17.3		20.2		23.3		26.5		29.9		33.3		36.9		40.6		48.3		56.5		65.2		74.4		84.0		100.4		114.8		129.1	
400	16.2		18.9		21.8		24.7		27.8		31.0		34.3		37.7		44.8		52.3		60.2		68.5		77.2		92.2		105.3		118.5	
500	15.3		17.9		20.6		23.4		26.3		29.3		32.4		35.6		42.2		49.8		56.5		64.3		72.3		86.2		98.5		110.8	
600	14.7		17.2		19.7		22.4		25.1		28.0		30.9		33.9		40.2		46.8		53.7		61.0		68.5		81.7		93.3		104.9	
700	14.2		16.5		19.0		21.6		24.2		26.9		29.7		32.6		38.6		44.9		51.5		58.3		65.5		78.0		89.1		100.1	
800	13.7		16.0		18.4		20.9		23.4		26.0		28.7		31.5		37.2		43.3		49.6		56.1		63.0		74.9		85.5		96.2	
870	13.5		15.7		18.0		20.4		22.9		25.5		28.1		30.8		36.4		42.3		48.4		54.8		61.4		73.0		83.4		93.7	
1000	13.0		15.2		17.4		19.8		22.1		24.6		27.1		29.7		35.1		40.7		46.5		52.6		58.9		70.0		79.9		89.8	
1160	12.6		14.7		16.8		19.1		21.3		23.7		26.1		28.6		33.7		39.1		44.6		50.4		56.4		66.9		76.3		85.7	
1400	12.0		14.0		16.1		18.2		20.4		22.6		24.9		27.2		32.0		37.1		42.3		47.7		53.2		63.1		71.9		80.7	
1450	11.9		13.9		15.9		18.0		20.2		22.4		24.6		27.0		31.7		36.7		41.9		47.2		52.7		62.4		71.1		79.8	
1600	11.7		13.6		15.6		17.6		19.7		21.8		24.0		26.3		30.9		35.7		40.7		45.8		51.1		60.4		68.9		77.2	
1750	11.4		13.3		15.2		17.2		19.2		21.3		23.5		25.6		30.1		34.8		39.6		44.6		49.7		58.7		66.8		74.9	
1800	11.3		13.2		15.1		17.1		19.1		21.2		23.3		25.5		29.9		34.5		39.3		44.2		49.2		58.2		66.2		74.1	
2000	11.1		12.9		14.7		16.6		18.6		20.6		22.7		24.7		29.0		33.5		38.1		42.8		47.6		56.2		63.9		71.4	
2500	10.5		12.2		13.9		15.7		17.6		19.4		21.3		23.3		27.3		31.4		35.6		39.9		44.2		51.9		58.8		65.5	
3000	10.0		11.7		13.3		15.0		16.7		18.5		20.3		22.1		25.8		29.7		33.5		37.5		41.5		48.5		54.6		60.5	
3600	9.6		11.1		12.7		14.3		15.9		17.6		19.3		21.0		24.4		27.9		31.5		35.1		38.6		44.8		50.1		55.0	
5000	8.8		10.2		11.6		13.1		14.5		15.9		17.4		18.9		21.8		24.7		27.6		30.4		33.1		37.4		40.6		43.0	
8000	7.8		8.9		10.1		11.2		12.3		13.4		14.4		15.4		17.3		19.0		20.4		21.5		22.3		—		—		—	
10000	7.2		8.2		9.2		10.1		11.0		11.9		12.7		13.4		14.5		15.3		—		—		—		—		—		—	

Continued on the next page

Shaded area indicates drive conditions where reduced service life can be expected.

For Belt Length	From		To		Length Correction Factor
	Length (mm)	# of teeth	Length (mm)	# of teeth	
1095	350	845	440	555	0.80
	70	169	88	111	
219	435	1090	550	840	1.00
	87	218	110	168	
220 & up	—	—	—	—	1.10
	—	—	0.90	1.00	

# TIMING BELTS, PULLEYS, CHAINS AND SPROCKETS

**Table 38 Rated Torque (Nm) for Small Pulleys - 9 mm Belt Width**

The following table represents the torque ratings for each belt, in its base width, at the predetermined number of grooves, pitch diameters and rpm's. These ratings must be multiplied by the appropriate width factor and applicable belt length factor to obtain the corrected torque rating (see **Step 7 of SECTION 24**, on page T-65).

## 5 mm Pitch PowerGrip® HTD® Belts

<b>Belt Width (mm)</b>	<b>9</b>	<b>15</b>	<b>25</b>
<b>Width Multiplier</b>	1.00	1.89	3.38

Number of Grooves Pitch Diameter	14	16	18	20	22	24	26	28	32	36	40	44	48	56	64	72
	mm	22.28	25.46	28.65	31.83	35.01	38.20	41.38	44.56	50.93	57.30	63.66	70.03	76.39	89.13	101.86
inches	.877	1.003	1.128	1.253	1.379	1.504	1.629	1.754	2.005	2.256	2.506	2.757	3.008	3.509	4.010	4.511
10	2.1	2.5	2.9	3.3	3.7	4.2	4.6	5.1	6.1	7.1	8.3	9.4	10.7	12.8	14.6	16.5
20	2.1	2.5	2.9	3.3	3.7	4.2	4.6	5.1	6.1	7.1	8.3	9.4	10.7	12.8	14.6	16.5
40	2.1	2.5	2.9	3.3	3.7	4.2	4.6	5.1	6.1	7.1	8.3	9.4	10.7	12.8	14.6	16.5
60	2.1	2.5	2.9	3.3	3.7	4.2	4.6	5.1	6.1	7.1	8.3	9.4	10.7	12.8	14.6	16.5
100	2.1	2.5	2.9	3.3	3.7	4.2	4.6	5.1	6.1	7.1	8.3	9.4	10.7	12.8	14.6	16.5
200	2.1	2.5	2.9	3.3	3.7	4.2	4.6	5.1	6.1	7.1	8.3	9.4	10.7	12.8	14.6	16.5
300	2.0	2.3	2.6	3.0	3.4	3.8	4.2	4.6	5.5	6.4	7.4	8.4	9.5	11.3	13.0	14.6
400	1.8	2.1	2.5	2.8	3.1	3.5	3.9	4.3	5.1	5.9	6.8	7.7	8.7	10.4	11.9	13.4
500	1.7	2.0	2.3	2.6	3.0	3.3	3.7	4.0	4.8	5.6	6.4	7.3	8.2	9.7	11.1	12.5
600	1.7	1.9	2.2	2.5	2.8	3.2	3.5	3.8	4.5	5.3	6.1	6.9	7.7	9.2	10.5	11.9
rpm of Fastest Shaft	700	1.6	1.9	2.1	2.4	2.7	3.0	3.4	3.7	4.4	5.1	5.8	6.6	7.4	8.8	10.1
	800	1.6	1.8	2.1	2.4	2.6	2.9	3.2	3.6	4.2	4.9	5.6	6.3	7.1	8.5	9.7
	870	1.5	1.8	2.0	2.3	2.6	2.9	3.2	3.5	4.1	4.8	5.5	6.2	6.9	8.2	9.4
	1000	1.5	1.7	2.0	2.2	2.5	2.8	3.1	3.4	4.0	4.6	5.3	5.9	6.7	7.9	9.0
	1160	1.4	1.7	1.9	2.2	2.4	2.7	3.0	3.2	3.8	4.4	5.0	5.7	6.4	7.6	8.6
[Tabulated values are in Nm]	1400	1.4	1.6	1.8	2.1	2.3	2.6	2.8	3.1	3.6	4.2	4.8	5.4	6.0	7.1	8.1
	1450	1.3	1.6	1.8	2.0	2.2	2.5	2.8	3.0	3.6	4.1	4.7	5.3	6.0	7.0	8.0
	1600	1.3	1.5	1.8	2.0	2.2	2.5	2.7	3.0	3.5	4.0	4.6	5.2	5.8	6.8	7.8
	1750	1.3	1.5	1.7	1.9	2.2	2.4	2.7	2.9	3.4	3.9	4.5	5.0	5.6	6.6	7.6
	1800	1.3	1.5	1.7	1.9	2.2	2.4	2.6	2.9	3.4	3.9	4.4	5.0	5.6	6.6	7.5
	2000	1.3	1.5	1.7	1.9	2.1	2.3	2.6	2.8	3.3	3.8	4.3	4.8	5.4	6.3	7.2
	2500	1.2	1.4	1.6	1.8	2.0	2.2	2.4	2.6	3.1	3.5	4.0	4.5	5.0	5.9	6.6
	3000	1.1	1.3	1.5	1.7	1.9	2.1	2.3	2.5	2.9	3.4	3.8	4.2	4.7	5.5	6.2
	3600	1.1	1.3	1.4	1.6	1.8	2.0	2.2	2.4	2.8	3.2	3.6	4.0	4.4	5.1	5.7
	5000	1.0	1.2	1.3	1.5	1.6	1.8	2.0	2.1	2.5	2.8	3.1	3.4	3.7	4.2	4.6
	8000	0.9	1.0	1.1	1.3	1.4	1.5	1.6	1.7	2.0	2.1	2.3	2.4	2.5	—	—
	10000	0.8	0.9	1.0	1.1	1.2	1.3	1.4	1.5	1.6	1.7	—	—	—	—	—

Shaded area indicates drive conditions where reduced service life can be expected.

For Belt Length	From	Length (mm)	350	440	555	845	1095
	To	# of teeth	70	88	111	169	219
Length Correction Factor	To	Length (mm)	435	550	840	1090	1100 & up
		# of teeth	87	110	168	218	220 & up
		Length Correction Factor	0.80	0.90	1.00	1.10	1.20

# TIMING BELTS, PULLEYS, CHAINS AND SPROCKETS

**Table 39 Rated Torque (ozf in.) for Small Pulleys - 1/8" Top Width**

The following table represents the torque ratings for each belt, in its base width, at the predetermined number of grooves, pitch diameters and rpm's. These ratings must be multiplied by the appropriate width factor to obtain the corrected torque rating (see **Step 7 of SECTION 24**, on page T-65).

## MXL (.080 in.) Belts

Belt Width (in.)	1/8	3/16	1/4	5/16	3/8	7/16	1/2
Width Multiplier	1.00	1.89	2.33	2.84	3.50	4.18	4.86

No. of Grooves		10	11	12	14	15	16	18	20	21	22
Pitch Diameter	mm	6.48	7.11	7.77	9.07	9.70	10.34	11.63	12.93	13.59	14.22
	in	.255	.280	.306	.357	.382	.407	.458	.509	.535	.560
rpm of Fastest Shaft	10	4.61	5.06	5.53	6.45	6.91	7.36	8.28	9.20	9.67	10.10
	100	4.61	5.06	5.53	6.45	6.91	7.36	8.28	9.20	9.67	10.10
	1000	4.61	5.06	5.53	6.45	6.91	7.36	8.28	9.20	9.67	10.10
	2000	4.61	5.06	5.53	6.45	6.90	7.36	8.28	9.20	9.67	10.10
	2500	4.61	5.06	5.53	6.45	6.90	7.35	8.28	9.20	9.66	10.10
	3000	4.61	5.06	5.53	6.45	6.90	7.35	8.27	9.19	9.66	10.10
	3500	4.61	5.06	5.53	6.45	6.90	7.35	8.27	9.19	9.66	10.10
	5000	4.61	5.06	5.53	6.44	6.89	7.34	8.26	9.17	9.64	10.10
	8000	4.60	5.05	5.52	6.43	6.87	7.32	8.22	9.12	9.58	10.00
	10000	4.59	5.04	5.51	6.41	6.85	7.30	8.19	9.08	9.53	9.96
12000	4.59	5.03	5.49	6.39	6.83	7.27	8.15	9.03	9.47	9.98	

No. of Grooves		24	28	30	32	36	40	42	44	48	60
Pitch Diameter	mm	15.52	18.11	19.41	20.70	23.29	25.88	27.18	28.45	31.04	38.81
	in	.611	.713	.764	.815	.917	1.019	1.070	1.120	1.222	1.528
rpm of Fastest Shaft	10	11.0	12.9	13.8	14.7	16.6	18.4	19.3	20.2	22.1	27.6
	100	11.0	12.9	13.8	14.7	16.6	18.4	19.3	20.2	22.1	27.6
	1000	11.0	12.9	13.8	14.7	16.6	18.4	19.3	20.2	22.1	27.6
	2000	11.0	12.9	13.8	14.7	16.6	18.4	19.3	20.2	22.0	27.5
	2500	11.0	12.9	13.8	14.7	16.5	18.4	19.3	20.2	22.0	27.4
	3000	11.0	12.9	13.8	14.7	16.5	18.3	19.2	20.1	21.9	27.3
	3500	11.0	12.8	13.8	14.7	16.5	18.3	19.2	20.1	21.9	27.2
	5000	11.0	12.8	13.7	14.6	16.4	18.2	19.1	19.9	21.7	26.8
	8000	10.9	12.7	13.5	14.4	16.1	17.8	18.6	19.4	21.0	25.5
	10000	10.8	12.6	13.4	14.2	15.9	17.4	18.2	18.9	20.4	24.3
12000	10.7	12.4	13.2	14.0	15.5	17.0	17.7	18.4	19.6	22.8	

NOTE: Tabulated values are in ozf in.

# TIMING BELTS, PULLEYS, CHAINS AND SPROCKETS

**Table 40 Rated Torque (lbf in.) for Small Pulleys - 1/4" Top Width**

The following table represents the torque ratings for each belt, in its base width, at the predetermined number of grooves, pitch diameters and rpm's. These ratings must be multiplied by the appropriate width factor to obtain the corrected torque rating (see **Step 7 of SECTION 24**, on page T-65).

## XL (.200 in.) Belts

Belt Width (in.)	1/4	5/16	3/8	7/16	1/2
Width Multiplier	1.00	1.29	1.59	1.89	2.20

No. of Grooves		10	11	12	14	15	16	18
Pitch Diameter	mm	6.48	7.11	7.77	9.07	9.70	10.34	11.63
	inches	.255	.280	.306	.357	.382	.407	.458
rpm of Fastest Shaft	10	2.32	2.55	2.78	3.24	3.47	3.71	4.17
	100	2.32	2.55	2.78	3.24	3.47	3.71	4.17
	500	2.32	2.55	2.78	3.24	3.47	3.70	4.17
	1000	2.32	2.54	2.78	3.24	3.47	3.70	4.16
	1160	2.32	2.54	2.78	3.24	3.47	3.70	4.16
	1450	2.31	2.54	2.78	3.24	3.47	3.70	4.16
	1600	2.31	2.54	2.78	3.24	3.47	3.70	4.16
	1750	2.31	2.54	2.77	3.23	3.47	3.70	4.15
	2000	2.31	2.54	2.77	3.23	3.46	3.69	4.15
	2500	2.31	2.54	2.77	3.23	3.46	3.69	4.14
	3000	2.31	2.54	2.77	3.22	3.45	3.68	4.13
	3500	2.31	2.53	2.76	3.22	3.44	3.67	4.12
	5000	2.30	2.52	2.75	3.19	3.41	3.63	4.06
	8000	2.27	2.48	2.70	3.11	3.32	3.52	3.90
	10000	2.24	2.45	2.65	3.04	3.23	3.41	3.75

No. of Grooves		20	21	22	24	28	30
Pitch Diameter	mm	12.93	13.59	15.52	18.11	19.41	20.70
	inches	.509	.535	.611	.713	.764	.815
rpm of Fastest Shaft	10	4.63	4.86	5.09	5.56	6.48	6.95
	100	4.63	4.86	5.09	5.56	6.48	6.95
	500	4.63	4.86	5.09	5.55	6.48	6.94
	1000	4.62	4.86	5.09	5.55	6.47	6.93
	1160	4.62	4.85	5.08	5.54	6.46	6.92
	1450	4.62	4.85	5.08	5.54	6.45	6.90
	1600	4.61	4.84	5.07	5.53	6.44	6.90
	1750	4.61	4.84	5.07	5.53	6.44	6.89
	2000	4.61	4.84	5.06	5.52	6.42	6.87
	2500	4.59	4.82	5.05	5.49	6.38	6.82
	3000	4.58	4.80	5.03	5.47	6.34	6.77
	3500	4.56	4.78	5.00	5.43	6.29	6.71
	5000	4.48	4.69	4.90	5.31	6.09	6.46
	8000	4.26	4.43	4.60	4.92	5.47	5.70
	10000	4.05	4.19	4.32	4.56	4.89	4.99

**NOTE:** Tabulated values are in lbf in.

# TIMING BELTS, PULLEYS, CHAINS AND SPROCKETS

**Table 41 Rated Horsepower for Small Pulleys - 10 mm Width**

The following table represents the horsepower ratings for each belt, in its base width, at the predetermined number of grooves, pitch diameters and rpm's. These ratings must be multiplied by the appropriate width factor to obtain the corrected torque rating (see **Step 7 of SECTION 24**, on page T-65).

T5 mm Pitch Belts					
Belt Width (mm)	4	6	10	16	25
Width Multiplier	0.4	0.6	1.0	1.6	2.5

Number of Grooves Pitch Diameter	mm		inches		12	14	15	16	18	19	20	22	24	26	28	30	32	40	60	
rpm of Fastest Shaft  [Tabulated values are in hp]	100	19.25	22.45	24.05	25.6	28.8	30.4	32	35.15	38.35	41.55	44.75	47.9	51.1	51.1	63.85	63.85	95.65	95.65	
	300	0.01	0.03	0.03	0.03	0.03	0.03	0.03	0.04	0.04	0.04	0.04	0.05	0.05	0.05	0.07	0.07	0.09	0.09	
	500	0.04	0.04	0.05	0.05	0.05	0.05	0.05	0.07	0.07	0.07	0.07	0.08	0.08	0.08	0.09	0.11	0.13	0.20	
	700	0.07	0.08	0.08	0.08	0.08	0.09	0.11	0.11	0.11	0.11	0.12	0.13	0.13	0.13	0.15	0.16	0.17	0.21	0.32
	1000	0.08	0.11	0.11	0.11	0.12	0.13	0.13	0.15	0.15	0.15	0.16	0.17	0.19	0.20	0.21	0.23	0.23	0.30	0.43
	1200	0.12	0.13	0.13	0.15	0.16	0.17	0.19	0.20	0.21	0.21	0.20	0.21	0.24	0.25	0.27	0.30	0.31	0.39	0.59
	1300	0.15	0.16	0.17	0.19	0.20	0.21	0.23	0.24	0.25	0.25	0.24	0.25	0.28	0.30	0.32	0.35	0.36	0.46	0.68
	1500	0.16	0.19	0.20	0.21	0.21	0.24	0.25	0.27	0.28	0.28	0.28	0.30	0.32	0.35	0.38	0.40	0.43	0.58	0.82
	1600	0.17	0.20	0.21	0.23	0.23	0.25	0.27	0.28	0.31	0.31	0.31	0.33	0.35	0.38	0.40	0.43	0.46	0.63	0.86
	1800	0.19	0.21	0.23	0.25	0.25	0.28	0.30	0.31	0.34	0.34	0.34	0.35	0.38	0.40	0.44	0.47	0.50	0.68	0.94
2000	0.20	0.24	0.25	0.30	0.32	0.31	0.32	0.34	0.38	0.40	0.42	0.46	0.51	0.55	0.59	0.63	0.67	0.83	1.26	
2200	0.21	0.25	0.27	0.30	0.32	0.32	0.35	0.36	0.40	0.40	0.40	0.43	0.47	0.51	0.55	0.58	0.62	0.72	1.02	
2300	0.23	0.27	0.28	0.30	0.34	0.34	0.36	0.38	0.42	0.44	0.44	0.48	0.52	0.56	0.60	0.60	0.63	0.75	1.13	
2500	0.24	0.28	0.30	0.32	0.34	0.36	0.38	0.40	0.44	0.44	0.44	0.48	0.52	0.55	0.59	0.63	0.67	0.79	1.19	
2700	0.25	0.30	0.31	0.34	0.34	0.38	0.40	0.42	0.46	0.48	0.48	0.50	0.55	0.55	0.59	0.63	0.67	0.83	1.26	
2800	0.25	0.30	0.32	0.35	0.35	0.39	0.40	0.43	0.47	0.48	0.48	0.51	0.56	0.60	0.64	0.68	0.68	0.86	1.29	
3000	0.27	0.31	0.34	0.36	0.40	0.40	0.43	0.46	0.50	0.54	0.56	0.62	0.67	0.72	0.76	0.80	0.83	1.09	1.35	
3200	0.28	0.34	0.35	0.38	0.40	0.43	0.44	0.47	0.52	0.56	0.56	0.62	0.66	0.71	0.75	0.79	0.82	1.04	1.41	
3600	0.31	0.36	0.38	0.40	0.43	0.46	0.48	0.51	0.56	0.60	0.60	0.66	0.71	0.76	0.82	0.82	1.02	1.53	1.99	
4000	0.32	0.38	0.40	0.43	0.44	0.50	0.52	0.55	0.60	0.64	0.66	0.71	0.76	0.82	0.87	0.90	1.09	1.64	2.29	
4200	0.34	0.39	0.42	0.44	0.44	0.51	0.54	0.56	0.62	0.67	0.69	0.72	0.79	0.84	0.90	0.94	1.13	1.69	2.39	
4600	0.36	0.42	0.44	0.47	0.48	0.54	0.56	0.59	0.66	0.71	0.78	0.83	0.90	0.95	1.01	1.06	1.25	1.84	2.59	
4800	0.36	0.43	0.46	0.48	0.50	0.55	0.58	0.62	0.67	0.74	0.79	0.86	0.91	0.98	1.04	1.09	1.28	1.84	2.59	
5000	0.38	0.44	0.47	0.50	0.54	0.56	0.59	0.63	0.68	0.75	0.82	0.87	0.94	1.01	1.06	1.11	1.28	1.84	2.59	
5500	—	—	—	—	0.47	0.50	0.54	0.56	0.60	0.67	0.72	0.79	0.86	0.93	0.99	1.06	1.13	1.33	2.00	
6000	—	—	—	—	—	0.56	0.63	0.67	0.70	0.76	0.84	0.91	0.98	1.05	1.11	1.19	1.33	2.00	2.09	
7000	—	—	—	—	0.62	0.68	0.72	0.76	0.84	0.93	0.99	1.07	1.15	1.22	1.28	1.33	1.53	2.09	2.09	
8000	—	—	—	—	—	0.74	0.79	0.83	0.91	0.99	1.07	1.15	1.23	1.33	1.33	1.53	1.65	2.09	2.09	
9000	—	—	—	—	—	0.79	0.84	0.89	0.97	1.06	1.15	1.23	1.33	1.41	1.41	1.65	1.77	2.09	2.09	
10000	—	—	—	—	—	0.84	0.89	0.94	1.03	1.13	1.22	1.31	1.41	1.50	1.50	1.77	1.84	2.09	2.09	

Shaded area indicates drive conditions where reduced service life can be expected.

# TIMING BELTS, PULLEYS, CHAINS AND SPROCKETS

**Table 42 Rated Horsepower for Small Pulleys - 10 mm Width**

The following table represents the horsepower ratings for each belt, in its base width, at the predetermined number of grooves, pitch diameters and rpm's. These ratings must be multiplied by the appropriate width factor to obtain the corrected torque rating (see **Step 7** of **SECTION 24**, on page T-65).

## T10 mm Pitch Belts

Belt Width (mm)	4	6	10	16	25
Width Multiplier	0.4	0.6	1.0	1.6	2.5

Number of Grooves	Pitch Diameter	mm	inches	12	14	15	16	18	20	21	24	25	26	27	30	40	48	50	72
				38.35	44.7	47.9	51.1	57.45	63.8	67	76.55	79.75	82.9	86.1	95.65	127.5	152.95	159.3	229.35
rpm of Fastest Shaft	100	0.05	0.07	0.07	0.08	0.08	0.09	0.09	0.09	0.09	0.11	0.12	0.12	0.12	0.13	0.19	0.23	0.23	0.34
	200	0.09	0.11	0.12	0.13	0.15	0.16	0.17	0.17	0.17	0.20	0.20	0.21	0.21	0.24	0.32	0.39	0.40	0.59
	500	0.21	0.25	0.27	0.28	0.32	0.35	0.38	0.43	0.43	0.43	0.44	0.46	0.46	0.54	0.71	0.86	0.89	1.27
	600	0.25	0.30	0.31	0.34	0.38	0.42	0.44	0.50	0.52	0.50	0.52	0.54	0.54	0.63	0.83	0.99	1.05	1.50
	800	0.32	0.38	0.40	0.43	0.48	0.54	0.56	0.64	0.67	0.64	0.67	0.70	0.70	0.72	0.79	1.06	1.27	1.33
	1000	0.39	0.44	0.48	0.51	0.58	0.64	0.67	0.76	0.80	0.76	0.80	0.83	0.83	0.86	0.97	1.27	1.54	1.60
	1200	0.44	0.52	0.56	0.59	0.67	0.74	0.78	0.89	0.93	0.89	0.93	0.97	0.97	1.01	1.11	1.49	1.78	1.85
	1400	0.51	0.59	0.63	0.67	0.75	0.84	0.89	1.01	1.05	1.01	1.05	1.09	1.13	1.26	1.68	2.01	2.09	3.02
	1500	0.54	0.62	0.67	0.71	0.79	0.89	0.93	1.06	1.11	1.06	1.11	1.15	1.15	1.19	1.33	1.77	2.12	2.21
	1600	0.56	0.66	0.70	0.75	0.83	0.93	0.98	1.11	1.17	1.11	1.17	1.21	1.21	1.26	1.39	1.86	2.24	2.32
	1800	0.62	0.71	0.76	0.82	0.91	1.02	1.07	1.22	1.27	1.22	1.27	1.33	1.37	1.37	1.53	2.04	2.44	2.55
	2000	0.66	0.76	0.83	0.89	0.99	1.10	1.15	1.33	1.38	1.33	1.38	1.43	1.49	1.65	2.20	2.64	2.75	3.66
	2200	0.71	0.83	0.89	0.94	1.05	1.18	1.23	1.42	1.48	1.42	1.48	1.53	1.60	1.77	2.36	2.83	2.95	3.97
	2400	0.75	0.89	0.94	1.01	1.13	1.26	1.31	1.52	1.57	1.52	1.57	1.64	1.70	1.89	2.52	3.02	3.14	4.53
	2500	0.78	0.91	0.97	1.03	1.17	1.30	1.35	1.56	1.62	1.56	1.62	1.69	1.74	1.94	2.59	3.11	3.23	4.67
	2600	0.80	0.94	0.99	1.06	1.19	1.33	1.39	1.60	1.66	1.60	1.66	1.73	1.80	2.00	2.67	3.19	3.33	—
2800	0.84	0.98	1.05	1.13	1.26	1.41	1.48	1.69	1.76	1.69	1.76	1.82	1.89	2.11	2.80	3.37	3.51	—	
3000	—	1.03	1.10	1.18	1.33	1.48	1.54	1.77	1.84	1.77	1.84	1.92	1.98	2.21	2.95	3.53	3.67	—	
3200	—	1.07	1.15	1.23	1.38	1.54	1.61	1.85	1.92	1.85	1.92	2.00	2.08	2.31	3.08	3.69	3.85	—	
3400	—	1.13	1.21	1.29	1.45	1.61	1.69	1.93	2.00	1.93	2.00	2.08	2.16	2.40	3.20	3.85	4.01	—	
3600	—	1.17	1.25	1.33	1.50	1.66	1.76	2.00	2.08	2.00	2.08	2.17	2.25	2.49	3.34	3.97	4.17	—	
3800	—	1.21	1.30	1.38	1.56	1.73	1.81	2.08	2.16	2.08	2.16	2.25	2.33	2.59	3.46	—	—	—	
4000	—	—	—	1.43	1.61	1.78	1.88	2.15	2.24	2.15	2.24	2.32	2.41	2.68	3.58	—	—	—	
4200	—	—	—	1.48	1.66	1.85	1.94	2.21	2.31	2.21	2.31	2.40	2.49	2.76	3.69	—	—	—	
4400	—	—	—	1.52	1.72	1.90	2.00	2.28	2.37	2.28	2.37	2.47	2.57	2.86	3.81	—	—	—	
4600	—	—	—	1.57	1.76	1.96	2.05	2.35	2.44	2.35	2.44	2.55	2.64	2.94	—	—	—	—	
4800	—	—	—	1.61	1.81	2.01	2.12	2.41	2.52	2.41	2.52	2.61	2.72	3.02	—	—	—	—	
5000	—	—	—	1.65	1.86	2.07	2.17	2.48	2.57	2.48	2.57	2.68	2.79	3.10	—	—	—	—	
5500	—	—	—	1.76	1.97	2.19	2.31	2.63	2.74	2.63	2.74	2.86	2.96	3.29	—	—	—	—	
6000	—	—	—	1.85	2.08	2.32	2.43	2.78	2.90	2.78	2.90	3.00	3.12	3.47	—	—	—	—	

Shaded area indicates drive conditions where reduced service life can be expected.

**Table 53 List of Tables**

<b>Table</b>	<b>Table Description</b>	<b>Page</b>
1	Comparison of Different Tension Member Materials .....	T-12
2	Comparison of Different Belt Body Materials .....	T-14
3	Allowable Working Tension of Different Belt Constructions .....	T-15
4	Basic Belt Dimensions .....	T-16
5	T2.5 (2.5 mm) Pitch Pulley Dimensions .....	T-18
6	T5 (5 mm) Pitch Pulley Dimensions .....	T-19
7	T10 (10 mm) Pitch Pulley Dimensions .....	T-20
8	Minimum Pulley Diameters .....	T-21
9	Belt Tensioning Force .....	T-30
10	Static Belt Tension, $T_{st}$ (lbf) Per Span – General Values .....	T-30
11	Idler Size Recommendations .....	T-36
12	Recommended Tension for Length Measurement .....	T-41
13	Belt Width Tolerances .....	T-41
14	Pitch Length Tolerances .....	T-41
15	Center Distance Tolerances .....	T-42
16	Overall Belt Thickness Dimensions .....	T-42
17	Overall Belt Thickness Tolerances .....	T-42

Continued on the next page

**Table 53 (Cont.) List of Tables**

<b>Table</b>	<b>Table Description</b>	<b>Page</b>
18	<b>Pulley O.D. Tolerances</b> .....	T-43
19	<b>Pulley Eccentricity</b> .....	T-43
20	<b>Bore Tolerance for Pulleys</b> .....	T-44
21	<b>Pulley Pitch Accuracy</b> .....	T-44
22	<b>ISO Axial Pulley Runout</b> .....	T-44
23	<b>ISO Radial Pulley Runout</b> .....	T-44
24	<b>ISO Pulley O.D. Tolerances</b> .....	T-45
25	<b>RMA Pulley Bore Tolerances</b> .....	T-45
26	<b>Nominal Flange Dimensions for Molding, Sintering, Casting, etc.</b> .....	T-47
27	<b>Additional Amount of Face Width Recommended over Nominal Belt Width</b> .....	T-47
28	<b>Belt Thickness Tolerances</b> .....	T-48
29	<b>Center Distance Tolerances</b> .....	T-48
30	<b>PowerGrip Long-Length Belting Specifications</b> .....	T-49
31	<b>Drive Ratio Tables</b> .....	T-53
32	<b>Center Distance Factor Tables</b> .....	T-60
33	<b>Rated Torque for Small Pulleys – 2 mm Pitch GT3 Belts</b> .....	T-67
34	<b>Rated Torque for Small Pulleys – 3 mm Pitch GT3 Belts</b> .....	T-70
35	<b>Rated Torque for Small Pulleys – 5 mm Pitch GT3 Belts</b> .....	T-71
36	<b>Rated Horsepower for Small Pulleys – 5 mm Pitch GT3 Belts</b> .....	T-73
37	<b>Rated Torque for Small Pulleys – 3 mm Pitch HTD Belts</b> .....	T-75
38	<b>Rated Torque for Small Pulleys – 5 mm Pitch HTD Belts</b> .....	T-77
39	<b>Rated Torque for Small Pulleys – MXL (.080") Pitch Belts</b> .....	T-79
40	<b>Rated Torque for Small Pulleys – XL (.200") Pitch Belts</b> .....	T-80
41	<b>Rated Horsepower for Small Pulleys – T5 mm Pitch Belts</b> .....	T-81
42	<b>Rated Horsepower for Small Pulleys – T10 mm Pitch Belts</b> .....	T-82
43	<b>List of Tables</b> .....	T-83
44	<b>List of Figures</b> .....	T-85

**Table 54 List of Figures**

<b>Figure</b>	<b>Figure Description</b>	<b>Page</b>
1	Pulley and Belt Geometry .....	T-3
2	Stress Pattern in Belts .....	T-4
3	Comparison of Different Tooth Profiles .....	T-4
4	Comparative Belt Pitch Selection Guide .....	T-6
5	Horsepower Ratings at High Speed .....	T-7
6	Horsepower Ratings at Low Speed .....	T-7
7	Comparison of Performance Ratios for Various Belts .....	T-8
8	Comparison of Tooth Jump Torques for Various Belts .....	T-8
9	Comparison of Noise Levels for Various Belts .....	T-9
10	Comparison of Positioning Errors of Various Belts .....	T-9
11	Double-Sided Timing Belt .....	T-10
12	Timing Belt Stock .....	T-10
13	Example of Timing Belt Stock Use .....	T-10
14	Belt Construction .....	T-10
15	Belt Cross Section .....	T-12
16	Cord Twist .....	T-13
17	Right-Hand Rule Applicable to "S" Twist .....	T-13
18	"S" and "Z" Cord Lay of the Mold .....	T-13
19	Belt Tooth Configuration .....	T-15
20	Force/Deflection Method .....	T-31
21	Shaft Separation Method .....	T-31
22	Single Tension Vector Force .....	T-31
23	Idler Forces .....	T-32
24	Sonic Tension Meter .....	T-32
25	Angular Misalignment .....	T-32
26	Parallel Misalignment .....	T-33
27	Cartesian Coordinate System .....	T-36
28	Example of 5-Point Drive System .....	T-37
29	Belt Pull Vector Diagram .....	T-38
30	Vector Sum Correction Factor .....	T-39
31	Overhung Pulley .....	T-39
32	Pulley Between Bearings .....	T-39
33	Length Measuring Fixture .....	T-40
34	Typical Pulley Groove Tolerance Band .....	T-43
35	Expressions Used in Flange and Pulley Design .....	T-46
36	Terms Used for Timing Pulley Flange Design .....	T-47
37	Twin Power Belt Tolerances .....	T-48
38	Twin Power Belt Application .....	T-48
39	Belt Nomenclature .....	T-52
40	Belt Geometry .....	T-58
41	GT3 Belt Selection Guide .....	T-62
42	HTD Belt Selection Guide .....	T-63
43	Trapezoidal Belt Selection Guide .....	T-64