

3.7 Standard Connection Example

3.7.1 Position (PT) Control Mode

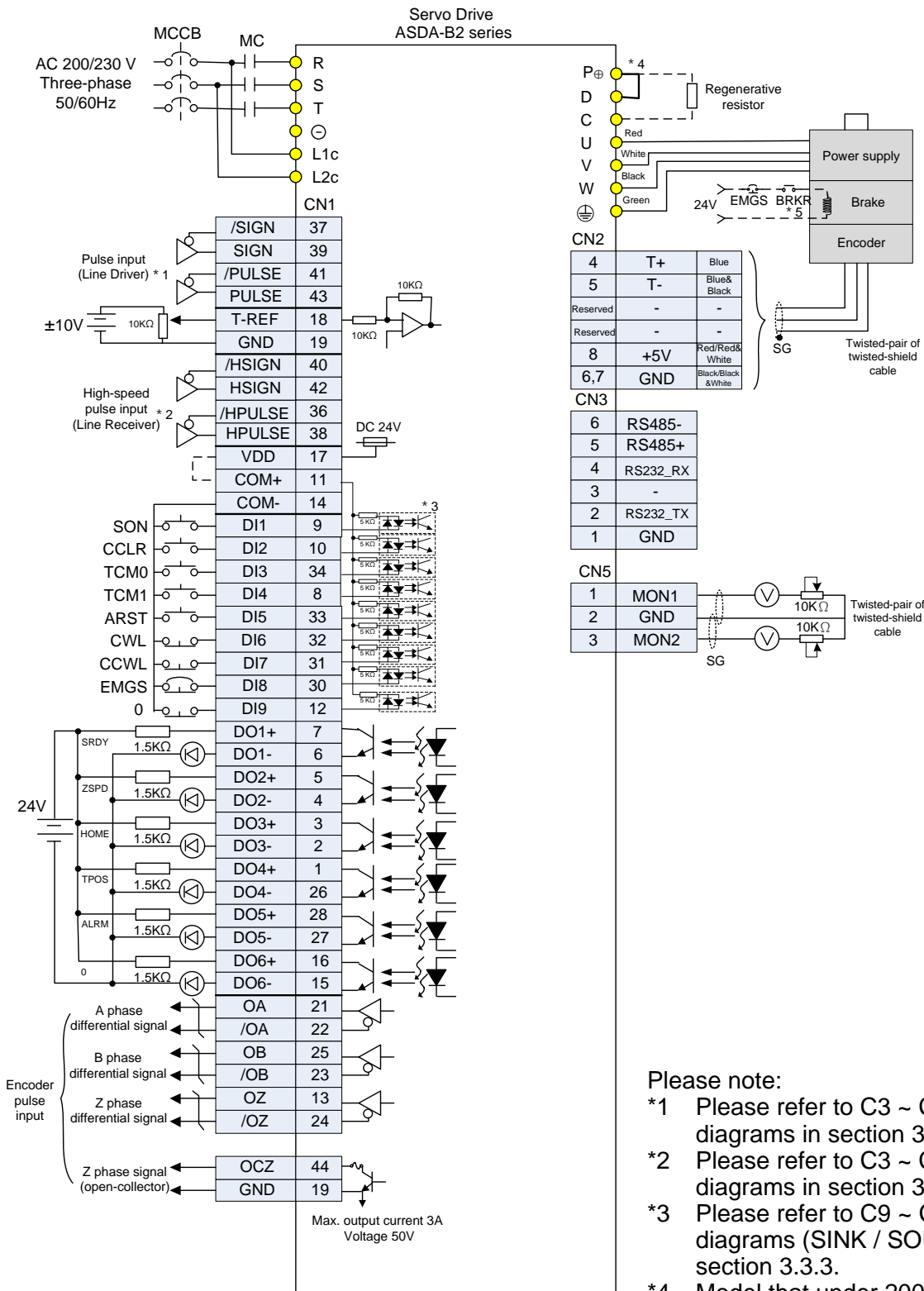

- Please note:
- *1 Please refer to C3 ~ C4 wiring diagrams in section 3.3.3.
 - *2 Please refer to C3 ~ C4 wiring diagrams in section 3.3.3.
 - *3 Please refer to C9 ~ C12 wiring diagrams (SINK / SOURCE mode) in section 3.3.3.
 - *4 Model that under 200W has no built-in regenerative resistor.
 - *5 The brake coil has no polarity.